

中華民國·交通部·台灣區高速公路工程局
 REPUBLIC OF CHINA·MINISTRY OF COMMUNICATIONS
 TAIWAN AREA FREEWAY CONSTRUCTION BUREAU

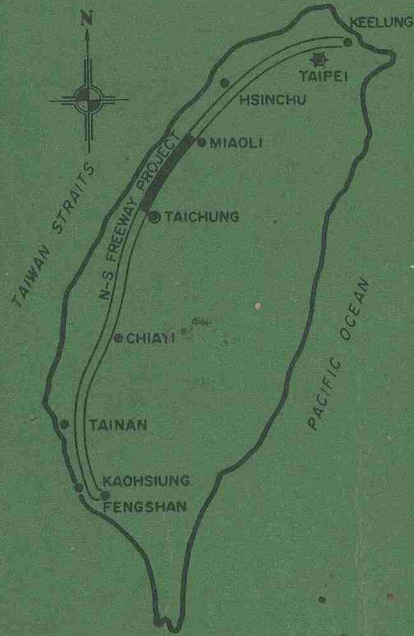

LOCATION MAP

南北高速公路
 NORTH-SOUTH FREEWAY
 苗栗台中段
 MIAOLI-TAICHUNG SECTION

細部設計圖
 DETAILED DESIGN PLANS

第六十標
 PROJECT 60 B
 TOLL PLAZA



中華顧問工程司
 CHINA ENGINEERING CONSULTANTS, INC.











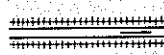

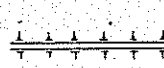
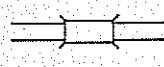
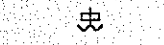
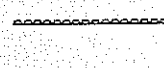
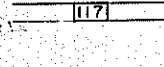

董事長 BOARD CHAIRMAN

台灣區高速公路工程局
 TAIWAN AREA FREEWAY CONSTRUCTION BUREAU

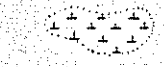







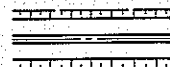
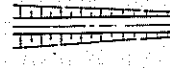
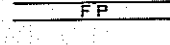
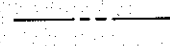
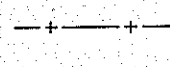
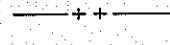
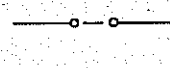

局長 DIRECTOR

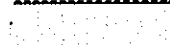
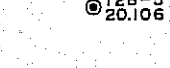
圖例 LEGEND

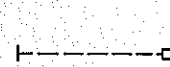
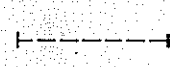
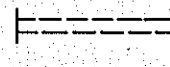
現有 EXISTING FEATURES

-  河流及溝渠
RIVER & CHANNEL
-  灌溉圳
ELEVATED IRRIGATION CANAL
-  水道
SMALL CREEK OR DITCH
-  堤防
LEVEE
-  土堤
EARTH DIKE
-  橋梁
BRIDGE
-  抽水站
PUMPING STATIONS
-  丁壩或石堤
GROYN OR STONE DIKE
-  公路及編號
HWY AND HWY NO.
-  農路
FIELD PATH
-  小路
TRAIL
-  省鐵路
TAIWAN RAILROAD
-  台糖鐵路
SUGAR RAILROAD
-  氣管
GAS LINE
-  稻田
RICE PADDY
-  甘蔗田
SUGAR CANE FIELD
-  墓地
CEMETERY
-  水池
POND
-  魚池
FISH POND
-  等高線
CONTOUR LINE
-  房屋
BUILDING

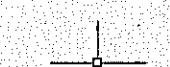
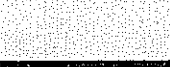
計劃 PROPOSED

-  高速公路 (路堤)
FREEWAY (EMBANKMENT)
-  高速公路 (路塹)
FREEWAY (CUT SECTION)
-  改線道路
RELOCATED ROAD
-  改線農路
RELOCATED FIELD PATH
-  路權線
ROW LINE SEPARATE FROM FENCE LINE
-  鐵絲網柵欄
WIRE MESH FENCE LINE SEPARATE FROM ROW
-  鐵絲網柵欄及路權線
ROW AND WIRE MESH FENCE LINE
-  鏈式鐵絲網柵欄
CHAIN LINK FENCE LINE SEPARATE FROM ROW
-  鏈式鐵絲網柵欄及路權線
ROW LINE AND CHAIN LINK FENCE LINE
-  緣石
CURB AND GUTTER
-  三明治擋土牆
SANDWICH RETAINING WALL
-  導線點
TRAVERSE POINT WITH ELEVATION
-  水準點
BENCH MARK
-  管涵
SINGLE RCP CULVERT
-  分隔帶排水口
MEDIAN INLET
-  緣石排水口
CURB INLET
-  單孔箱涵
SINGLE RC BOX
-  雙孔箱涵
DOUBLE RC BOX
-  倒虹吸管
INVERT SIPHON
-  水溝及流向
FLOW DIRECTION FOR RELOCATED DITCH
-  橋端排水
BRIDGE END DRAINAGE
-  舍水箱
FARM TURN OUT

一般說明

1. 平面控制，採用航空攝影測量系統，以虎子山三角點為原點。
2. 高程以基隆平均海面為零公尺起算。
3. 高速公路路線已測設等線點及水準點，並備有座標及高程資料。
4. 工程局另備有路線圖。
5. 整地土不得用以填築路基及構造物間填，但可如剖面圖所示，用以填築路肩外圍填及中央分隔帶中間不鋪面部份，如仍有剩餘應敷佈於路堤邊坡之上。
6. 高速公路交流道、休息站、收費站及其他改線新築道路皆另備有平面及立面控制電子計算機計算成果，包括中心線、中心線偏設、路面高程等資料，承包商於施工前應加核校，如發現誤差應即通知施工工程局。
7. 除另有說明外，圖面上所示之高程皆為竣工高程即路堤及結構物之沉陷應已到達規範上規定之最大沉陷量。
8. 高速公路應有之路面標點見標準圖。
9. 柵欄門之位置見平面圖，工程局可指示另行加設，並指定其位置及尺寸。
10. 施工範圍內所有道路與已有之鄰近道路連接，應在過渡之漸變長度內，使新築及已有道路之中線、縱坡及路寬順接。
11. 民國六十二年現地測量帶號 111+850~112+850 及帶號 117+050~129+500 間地面線，結果與繪製平面與縱面用之地形圖不盡符合，設計填挖方及腳線，應採據土層高，型式依現地測繪地面線為準，施工時應再予校核。
12. 使用極細土層延伸樁樑溝渠，須與溝渠順接，並須與結構圖及結構圖上所示之位置、方向及埋置高程符合。
13. 在河川橋樑前後，及河川橋樑間每間距五公里宜設中央分隔帶前路面路口，以備在特殊情形下車輛轉彎或改道行駛，標準設計及設置位置，由工程局指定之。

GENERAL NOTES

1. HORIZONTAL DATUM IS BASED ON THE HU-TZU-SHAN DATUM POINT, UNIVERSAL TRANSVERSE MECA TOR COORDINATES SYSTEM.
2. VERTICAL DATUM IS BASED ON MEAN SEA LEVEL TIDAL STATION, KEE-LUNG.
3. COORDINATES AND ELEVATION DATA FOR SURVEYED TRAVERSE POINTS AND BENCH MARKS ALONG THE FREEWAY CORRIDOR WILL BE FURNISHED.
4. SEPARATE R.O.W. PLANS ARE AVAILABLE FROM TAFCB.
5. TOPSOIL FROM STRIPPING SHALL NOT BE USED AS FILL MATERIAL FOR EMBANKMENT OR STRUCTURAL BACKFILL BUT FOR MEDIAN UNPAVED AREA AND SHOULDER ROUNDING AS SHOWN ON THE PLANS. IF THERE IS SURPLUS, THE MATERIAL SHALL BE SPREAD ON THE SLOPE SURFACES.
6. COMPUTERIZED DATA FOR HORIZONTAL AND VERTICAL CONTROL (ORTHOGONALITY AND POLARITY, COORDINATES, AND PAVEMENT ELEVATIONS) OF FREEWAY, INTERCHANGES, REST AREA, TOLL PLAZA, AND OTHER ROADS ARE FURNISHED IN SEPARATE PACKAGE. THE CONTRACTOR SHALL VERIFY THE FURNISHED DATA AND SHALL NOTIFY THE ENGINEER OF ANY DISCREPANCY BEFORE WORK BEGINS.
7. UNLESS OTHERWISE INDICATED, ELEVATIONS SHOWN ON THE PLANS ARE THE FORMATION LEVELS AFTER THE SETTLEMENT OF EMBANKMENT OR STRUCTURES IS REACHED TO ITS MAXIMUM AS SPECIFIED IN THE SPECIFICATIONS.
8. PAVEMENT MARKERS USED FOR FREEWAY TYPICAL SECTION ARE SHOWN ON THE HIGHWAY STANDARD DETAILS.
9. UNLESS OTHERWISE INDICATED ON THE PLAN, THE ARRANGEMENTS AND LOCATIONS OF THE FENCE GATES WILL BE DETERMINED BY THE ENGINEER IN THE FIELD.
10. AT LIMITS OF CONSTRUCTION, ALL ROADS OF THIS PROJECT SHALL BE LINED AND GRADED TO MEET THE EXISTING ROADS ALONG THE ADEQUATE LENGTH OF TRANSITION FOR DIFFERENCES IN ROADWAY WIDTHS AND DEVIATIONS IN LINES AND GRADES.
11. THE TOE LINE OF CUT AND FILL AND THE HEIGHT OF CRIB WALL ARE BASED ON THE GROUND LINE FIELD SURVEYED IN 1973 FOR THE MOUNTAINOUS AREAS BETWEEN STA. 111+650, AND STA. 112+350 STA. 117+050 AND STA. 129+500. THE SURVEY HAS SHOWN THAT THE GROUND LINE IS OF SOME DEVIATION FROM THAT INDICATED BY THE TOPOGRAPHY AS SHOWN ON THE PLAN AND PROFILE SHEETS. DURING CONSTRUCTION, THE GROUND LINE SHALL BE VERIFIED TO ADJUST THE CRIB WALL HEIGHT AND TYPE TO ENSURE DEPTH OF COVER SPECIFIED, AND TO DETERMINE THE ACTUAL TOE LINE.
12. CRIB WALL USED TO EXTEND BRIDGE WING WALLS SHALL JOIN THE WING WALL ENDS, AND TO BE PLACED TO THE LINES AND ELEVATIONS AS SHOWN ON STRUCTURAL AND HIGHWAY PLANS.
13. PAVED MEDIAN OPENINGS LOCATED AT RIVER CROSSINGS AND BETWEEN THESE POINTS AT INTERVALS ABOUT 5 KM ARE PROPOSED. THEIR EXACT LOCATIONS AND ARRANGEMENT WILL BE DETERMINED BY THE ENGINEER.

PROJECT 60

修正 REVISIONS	項目 ITEM	日期 DATE

交通部台灣區高速公路工程局
TAIWAN AREA FREEWAY CONSTRUCTION BUREAU
中華民國
REPUBLIC OF CHINA
南北高速公路 NORTH-SOUTH FREEWAY
苗栗台中段 MIAOLI-TAICHUNG SECTION
圖例及一般說明 LEGEND AND GENERAL NOTE
中華顧問工程司 CHINA ENGINEERING CONSULTANTS.
日期 DATE AUG. '74 比例 SCALE NONE 圖號 SHEET A-1

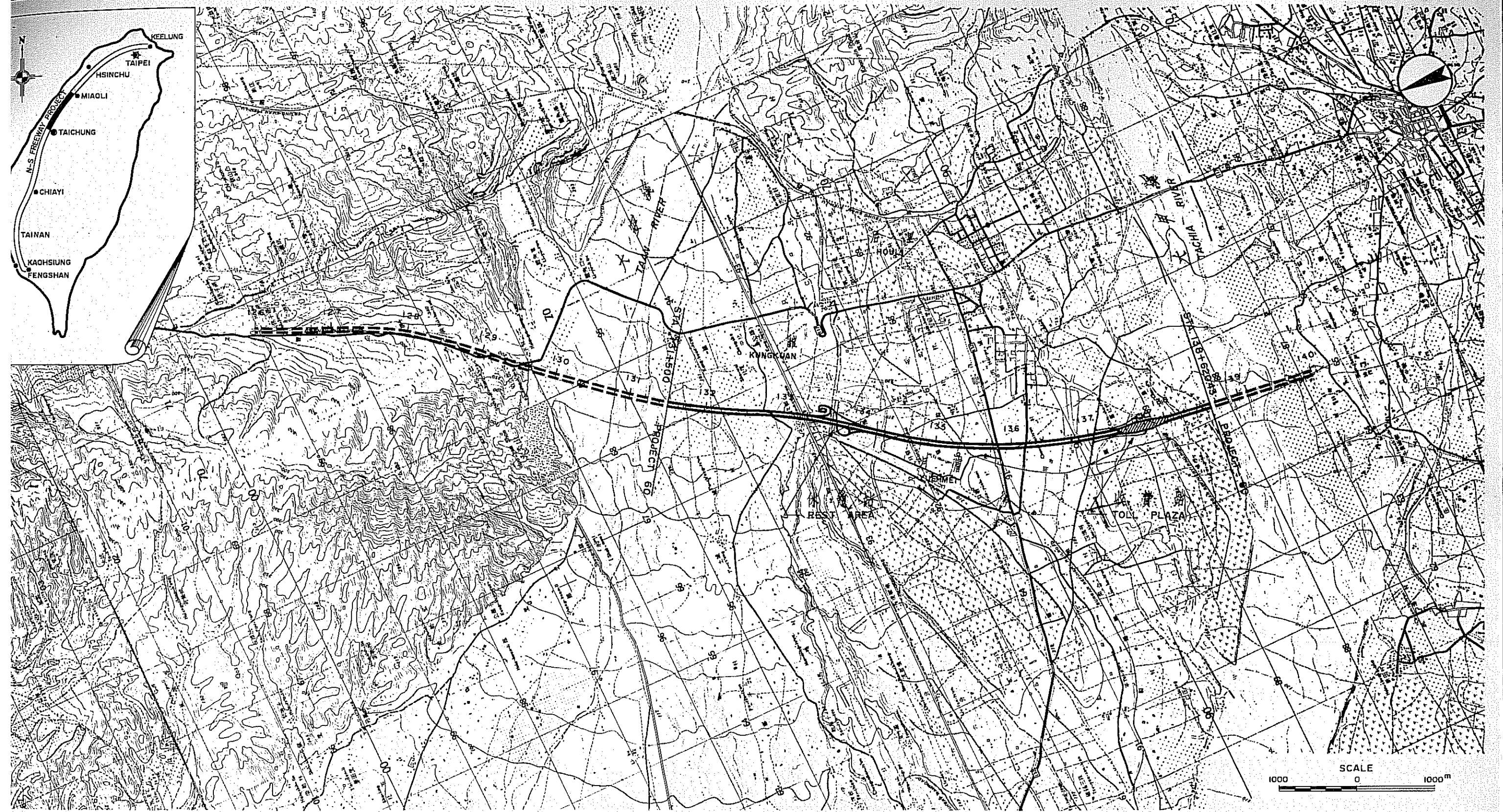

PROJECT 60

REVISIONS		
項	ITEM	日期 DATE

交通部台灣區高速公路工程局
 TAIWAN AREA FREEWAY CONSTRUCTION BUREAU
 中華民國
 交通部公路局
 NORTH-SOUTH FREEWAY
 苗栗台中段
 MIAOLI-TAICHUNG SECTION

總平面圖
 GENERAL PLAN

設計單位：CHINA ENGINEERING CONSULTANTS, INC.
 日期：AUG. '74
 比例尺：AS SHOWN
 圖號：A-3

DESCRIPTION

UNIT ESTIMATED QUANTITY

DESCRIPTION

UNIT ESTIMATED QUANTITY

DESCRIPTION

UNIT ESTIMATED QUANTITY

1	CLEARING AND GRUBBING	Ha	11	50	STEEL CUTTING EDGE	MT	—	100	LIGHT RAIL, 8 KG/LM	Lin. M	—
2	DEMOLITION	L. S.	ONE	51	SINKING OF CAISSON, 5.5 M ϕ	Lin. M	—	101	OUTLET BOX, TYPE A	Each	56
3	EXCAVATION, UNSUITABLE MATERIAL	M ³	1,000	52	6.0 M ϕ	Lin. M	—	102	OUTLET BOX, TYPE B	Each	60
4	ROADWAY EXCAVATION	M ³	549,800	53	6.5 M ϕ	Lin. M	—	103	DRAIN INLET	Each	2
5	EMBANKMENT	M ³	1,034,000	54	7.0 M ϕ	Lin. M	—	104	BRIDGE END DRAINAGE INLET	Each	21
6	SETTLEMENT PLATFORMS	Each	12	55	PRECAST PILE, 20 ^{cm} ϕ	Lin. M	—	105	BRIDGE END DRAINAGE OUTLET BOX	Each	—
7	ROADWAY FINISHING	L. S.	ONE	56	CHANNEL EXCAVATION	M ³	54,900	106	WIRE SAUSAGE, TYPE I	Lin. M	660
8	SUBBASE	M ³	41,500	57	CONCRETE, 5 SACK	M ³	65	107	GRAVEL BACKFILL FOR DRAIN	M ³	2,670
9	AGGREGATE BASE	M ³	12,300	58	CYCLOPEAN CONCRETE	M ³	—	108	MANHOLE	Each	—
10	BITUMINOUS TREATED PLANT MIXED BASE	M ³	12,820	59	RC-PIPE CULVERT, 30 cm ϕ , CLASS I	Lin. M	—	109	STEEL GRATE AND FRAME, W-70 cm	Lin. M	108
11	ASPHALT CONCRETE AGGREGATE, "DENSE GRADED"	MT	36,700	60	40 cm ϕ , CLASS I	Lin. M	12	110	CAST IRON PIPE, 20 cm ϕ	Lin. M	—
12	ASPHALT, PENETRATION GRADE 85-100	MT	3,530	61	40 cm ϕ , CLASS II	Lin. M	—	111	ROCK SLOPE PROTECTION, METHOD B, FACING CLASS	M ²	—
13	LIQUID ASPHALT, RC 70, FOR PRIME AND TACK COAT	Liter	333,600	62	60 cm ϕ , CLASS I	Lin. M	—	112	PCC-CURB, TYPE A	Lin. M	574
14	ASPHALT SURFACE TREATMENT, DOUBLE	M ²	13,830	63	60 cm ϕ , CLASS II	Lin. M	3,677	113	PCC-CURB AND GUTTER, TYPE B	Lin. M	1,140
15	PORTLAND CEMENT CONCRETE PAVEMENT, T=20cm	M ²	14,164	64	60 cm ϕ , CLASS III	Lin. M	1,198	114	METAL BEAM GUARD RAIL, SINGLE	Lin. M	21,540
16	SIDEWALK CONCRETE PAVEMENT, T=10cm	M ²	126	65	60 cm ϕ , CLASS I	Lin. M	—	115	METAL BEAM GUARD RAIL, DOUBLE	Lin. M	—
17	STRUCTURE EXCAVATION	M ³	61,710	66	60 cm ϕ , CLASS II	Lin. M	631	116	REINFORCED CONCRETE GUIDE POST	Lin. M	3,130
18	STRUCTURE BACKFILL	M ³	42,620	67	60 cm ϕ , CLASS III	Lin. M	966	117	CHAIN LINK FENCE	Lin. M	3,890
19	PERVIOUS BACKFILL	M ³	2,850	68	60 cm ϕ , CLASS IV	Lin. M	58	118	WIRE MESH FENCE	Lin. M	11,050
20	CONCRETE (80 kg/cm ²), 4 SACK	M ³	4,525	69	60 cm ϕ , CLASS V	Lin. M	70	119	SIGN, SHEET ALUMINUM PANEL	M ²	33
21	(176 kg/cm ²), 6 SACK	M ³	85	70	100 cm ϕ , CLASS I	Lin. M	—	120	SIGN, EXTRUDED ALUMINUM PANEL	M ²	179
22	(240 kg/cm ²), 7 SACK	M ³	13,261	71	100 cm ϕ , CLASS II	Lin. M	76	121	PAVEMENT STRIPING	M ²	1,570
23	PLACED UNDER WATER, 8 SACK	M ³	—	72	100 cm ϕ , CLASS III	Lin. M	250	122	PAVEMENT MARKER, NON-REFLECTORIZED	Each	18,174
24	(320 kg/cm ²), 8 SACK	M ³	—	73	100 cm ϕ , CLASS IV	Lin. M	70	123	PAVEMENT MARKER, REFLECTORIZED	Each	4,646
25	PRESTRESSED CONCRETE, CAST-IN-PLACE, (350 kg/cm ²), 9 SACK	M ³	1,866	74	100 cm ϕ , CLASS V	Lin. M	142	124	SEEDING AND MULCHING	Ha	24
26	PRESTRESSING WIRE	MT	67	75	120 cm ϕ , CLASS I	Lin. M	—	125	SEEDING WITH LOAM STRIP	Ha	—
27	PRECAST RC-GIRDER, 7.8 M	Each	—	76	120 cm ϕ , CLASS II	Lin. M	—	126	REINFORCED CONCRETE CRIB UNIT	Lin. M	—
28	PC-GIRDER, 17.8 M, TYPE III	Each	10	77	120 cm ϕ , CLASS III	Lin. M	—	127	GRILLAGE TYPE SLOPE PROTECTION	M ²	—
29	19.94 M, TYPE IV	Each	—	78	120 cm ϕ , CLASS IV	Lin. M	—	128	MORTAR GROUTED ROCK, 30 cm ϕ	M ²	290
30	19.94 M, TYPE VIII	Each	—	79	120 cm ϕ , CLASS V	Lin. M	—	129	HIGHWAY 117 TEMPORARY DETOUR	L. S.	—
31	21.94 M, TYPE IV	Each	—	80	150 cm ϕ , CLASS I	Lin. M	—	130	CONCRETE PAVEMENT, 7 SACK	M ³	—
32	24.94 M, TYPE IV, SPACING 2.3 M	Each	—	81	150 cm ϕ , CLASS II	Lin. M	—	131	CONCRETE MEDIAN BARRIER	Lin. M	215
33	24.94 M, TYPE IV, SPACING 2.6 M	Each	—	82	150 cm ϕ , CLASS III	Lin. M	—	132	RUMBLE STRIPING	M ²	32
34	29.94 M, TYPE V	Each	—	83	150 cm ϕ , CLASS IV	Lin. M	—	133	HIGHWAY LIGHTING SYSTEM	L. S.	ONE
35	30.94 M, TYPE VII	Each	—	84	150 cm ϕ , CLASS V	Lin. M	—	134	TOLL PLAZA ROADWAY LIGHTING SYSTEM	L. S.	ONE
36	33.94 M, TYPE VII	Each	—	85	PERFORATED PVC PIPE, 20 cm ϕ	Lin. M	2,562	135	TOLL PLAZA AND TOLL PLAZA ADMINISTRATION BUILDING	L. S.	ONE
37	34.94 M, TYPE VII, SPACING 2.35 M	Each	—	86	PVC PIPE, 20 cm ϕ	Lin. M	72	136	PICK UP TRUCK	Each	2
38	34.94 M, TYPE VII, SPACING 2.6 M	Each	—	87	MEDIAN INLET	Each	183	137	FOUR WHEEL DRIVE	Each	2
39	39.94 M, TYPE VIII	Each	—	88	GUTTER INLET	Each	82	138	TEMPORARY CONSTRUCTION OF HOU-LI CANAL	L. S.	ONE
40	STEEL REINFORCEMENT, BARS	MT	1,450	89	CONCRETE GROUTED ROCK, 30 cm ϕ	M ²	13,985	139	ALUMINUM RAILING	Lin. M	100
41	CONCRETE BLOCK SLOPE PROTECTION, (WITH 7 cm GRAVEL BASE)	M ²	4,462	90	CONCRETE GROUTED ROCK, 20 cm ϕ	M ²	13,700	140	FILL MATERIAL	M ³	3,700
42	ELASTOMERIC EXPANSION JOINT SEAL, b=57.8 cm	Lin. M	—	91	RIPRAP, 1/4 MT CLASS	M ³	96				
43	ELASTOMERIC EXPANSION JOINT SEAL, b=34.4 cm	Lin. M	—	92	RIPRAP, LIGHT CLASS	M ³	600				
44	DECK EXPANSION JOINT	Lin. M	185	93	RIPRAP, FACING CLASS	M ³	530				
45	METAL BRIDGE RAILING, TYPE I	Lin. M	139	94	CONCRETE LINING DITCH OR GUTTER, T=7.5 cm	M ²	8,000				
46	METAL BRIDGE RAILING, TYPE II	Lin. M	899	95	CONCRETE LINING DITCH OR GUTTER, T=10.0 cm	M ²	43,108				
47	PVC CONDUIT, 7.5 cm ϕ	Lin. M	—	96	CONCRETE LINING DITCH OR GUTTER, T=12.0 cm	M ²	—				
48	SCUPPER	Each	4	97	TRILEG BLOCK, 5 MT	Each	102				
49	PVC DRAIN PIPE, 20 cm ϕ	Lin. M	36	98	TRILEG BLOCK, 7 MT	Each	—				
				99	PRECAST CONCRETE U-CHANNEL, 40 cm x 30 cm x 50 cm	Each	811				

PROJECT 60

修正 REVISIONS		交通部台灣區高速公路工程局	
項目 ITEM	日期 DATE	TAIWAN AREA FREEWAY CONSTRUCTION BUREAU	
		中華民國 REPUBLIC OF CHINA	
		南北高速公路 NORTH-SOUTH FREEWAY	
		苗栗台中段 MIAOLI-TAICHUNG SECTION	
		工程數量表 SUMMARY OF QUANTITIES	
		中華顧問工程行 CHINA ENGINEERING CONSULTANTS, INC.	
		日期 DATE AUG. '74 比例 SCALE NONE 圖號 SHEET A-4	

溝渠 DITCH

DITCH NO.	LOCATION	TYPE	LENGTH (LM)	DIMENSION (CM)				RELATED STRUCTURE	
				B	h	H	Z	LOCATION	STRUCTURE
157	RAMP 1 0+060 RT. 0+250 RT.	GUI	190						
158	0+080 LT. 0+150 LT.	GUI	70						
159	RAMP 5 0+050 LT. 0+300 LT.	GUI	220						
160	0+160 RT. 0+350 RT.	GUI	190						
	HWY 44								
161	0+050 RT. 6.0 0+000 LT. 5.0	E	760	40	60				
162	0+050 RT. 7.0 0+175 RT. 12.0	E	125	160	110				
163	0+350 RT. 27 0+365 RT. 24	A	16	40	60			1.5	
164	0+750 RT. 8.0 0+800 RT. 8.0	E	50	160	110				
	HWY 26								
165	0+000 LT. 3.0 0+260 LT. 4.0	D	260	40	60			1	0+055 LT. FARM TURNOUT
	HWY 37								
166	0+050 LT. 7.0 0+125 LT. 7.0	D	75	40	60			1	0+120 LT. FARM TURNOUT
167	0+095 RT. 8.0 0+110 RT. 6.0	D	15	40	80			1	
168	0+110 RT. 6.0 0+200 RT. 13	D	90	40	80			1	0+200 RT. FARM TURNOUT
169	0+260 LT. 18 0+300 LT. 30	D	50	40	60			1	
170	0+350 RT. 18 0+425 RT. 15	E	75	40	90			1	
171	0+610 RT. 10 0+610 RT. 25	D	15	40	60			1	
172	0+300 RT. 19 0+318 RT. 20	E	20	40	60			1	
173	0+343 LT. 21 0+360 LT. 23	E	20	40	60			1	
	HWY 132								
174	0+065 RT. 8 0+500 RT. 20	F	440	100	150				
175	0+280 LT. 23 0+300 LT. 35	E	25	40	60			1	
176	0+280 RT. 22 0+290 RT. 39	E	10	40	60			1	
177	0+500 LT. 21 0+520 LT. 12	E	20	40	60			1	
178	0+525 LT. 16 0+675 LT. 8	E	50	100	120			1	
	HWY 36								
179	0+048 RT. 5 0+145 RT. 10	D	100	40	60			1	

溝渠 DITCH

DITCH NO.	LOCATION	TYPE	LENGTH (LM)	DIMENSION (CM)				RELATED STRUCTURE	
				B	h	H	Z	LOCATION	STRUCTURE
180	0+060 LT. 6.0 0+110 LT. 10.0	D	50	40	60			1	
181	0+270 LT. 21 0+280 LT. 25	BF	10	120	120				
182	0+270 RT. 22 0+285 RT. 27	E	15	40	60			1	
183	0+320 LT. 30 0+333 LT. 23	E	15	40	60			1	
184	0+327 RT. 27 0+336 RT. 22	E	15	40	60			1	
185	0+160 LT. 11 0+170 LT. 20	D	10	40	60			1	
186	0+537 LT. 13 0+550 LT. 15	E	15	80	80			1	
	HWY 31								
187	0+075 RT. 6.0 0+317 RT. 30	E	245	100	100			1	
188	0+428 RT. 17 0+570 RT. 4	D	150	40	60			1	
189	132+455 LT. 24 132+470 LT. 24	D	15	40	60				132+470 LT. FARM TURNOUT
190	137+740 RT. 44 137+807 RT. 47	D	70	40	60			1	
	"LT" FRONTAGE RD.								
191	137+115 LT. 78 137+145 LT. 73	D	35	40	60			1	
192	0+020 LT. 21 0+110 LT. 17	D	100	40	60			1	
193	0+120 LT. 17 0+195 LT. 10	C	75	80	80			1	
194	0+260 LT. 9 0+430 LT. 9	C	160	100	100			1	
195	0+440 LT. 9 0+520 LT. 9	C	90	100	100			1	
196	0+430 LT. 35 0+435 LT. 7	D	23	40	60			1	
197	0+519 LT. 60 0+519 LT. 7	F	53	150	150			1	
	"RT" FRONTAGE RD.								
198	0+000 RT. 106 0+018 RT. 26	D	240	40	60			1	0+141 RT. FARM TURNOUT
199	0+141 RT. 18 0+465 RT. 6	D	24	40	60			1	
200	0+472 RT. 23 0+546 RT. 7.0 0+586 RT. 16.0	F	45	150	150			1	
202	137+969 LT. 46 137+978 LT. 17	D	31	40	60			1	
	SERVICE I.D. (REST AREA)								
203	0+019 0+125	FRANCHISE DRAIN	108						0+105 RT. RCP 1-60.6

溝渠 DITCH

DITCH NO.	LOCATION	TYPE	LENGTH (LM)	DIMENSION (CM)				RELATED STRUCTURE	
				B	h	H	Z	LOCATION	STRUCTURE
204	132+975 LT. 70 132+986 LT. 33 133+007 RT. 35	P	37	600		200	1		TRANSITION
	133+007 RT. 70 133+154 RT. 45	P	35	1000		200	1		TRANSITION
205	133+020 RT. 46 132+959 LT. 52	F	134	1.5		1.0	1		
206	133+341 LT. 55 133+318 LT. 50	CHUTE	138.74						
207	133+385 LT. 32.5 133+318 LT. 55	CHUTE	72.6						
208	133+320 LT. 22 133+300 LT. 66	CHUTE	28						
209	133+318 LT. 55 133+323 RT. 26	CHUTE	16.46						
210	133+333 RT. 16.5 133+323 RT. 26	CHUTE	12.5						
211	133+351 RT. 32	CHUTE	18.15						
2'	131+600 LT. 30 131+690 LT. 30	D	90	40	60			1	
4'	131+730 LT. 27 131+750 LT. 27	D	20	40	60			1	
17'	132+280 RT. 23 132+305 RT. 23	D	25	40	60			1	
35'	133+087 RT. 33 133+215 RT. 33	D	128	40	60			1	133+160 FARM TURNOUT
104'	133+260 LT. 37 133+300 LT. 31	D	40	40	60			1	
	HWY 26								
165'	0+000 RT. 3 0+050 RT. 8	D	50	40	60			1	

BF : BENCH FLUME

ET : END TREATMENT

PROJECT 60

修正 REVISIONS	項目 ITEM	日期 DATE

交通部台灣區高速公路工程局
TAIWAN AREA FREEWAY CONSTRUCTION BUREAU
中華民國
南北高速公路 NORTH-SOUTH FREEWAY
苗栗台中段 MIAOLI-TAICHUNG SECTION

排水設施一覽表(III) CONSTRUCTION TABLE OF DRAINAGE FACILITIES.(III)
中華顧問工程司 CHINA ENGINEERING CONSULTANTS, INC.
日期 DATE AUG '74 比例 SCALE NONE 圖號 SHEET D-3

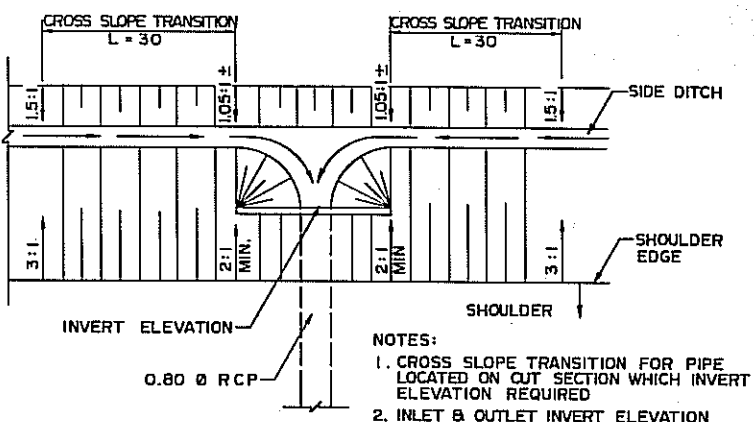
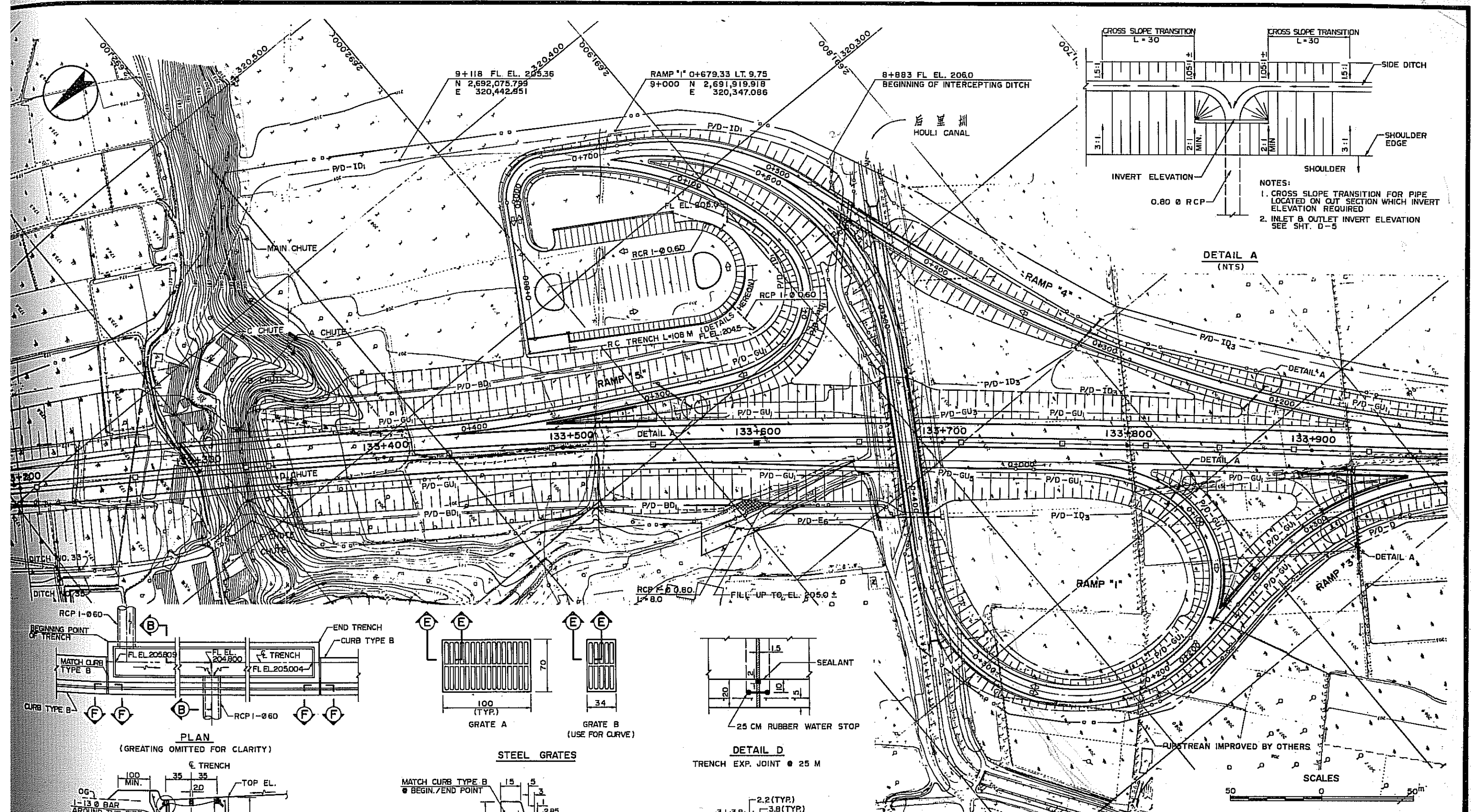

- NOTES:
- CROSS SLOPE TRANSITION FOR PIPE LOCATED ON CUT SECTION WHICH INVERT ELEVATION REQUIRED
 - INLET & OUTLET INVERT ELEVATION SEE SH. D-5

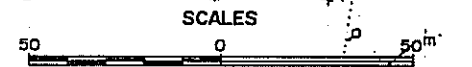
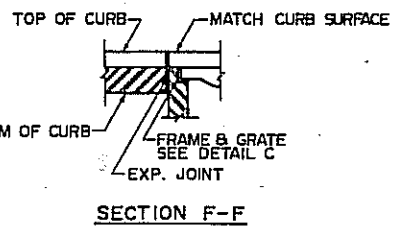
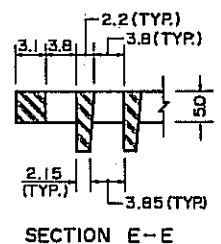
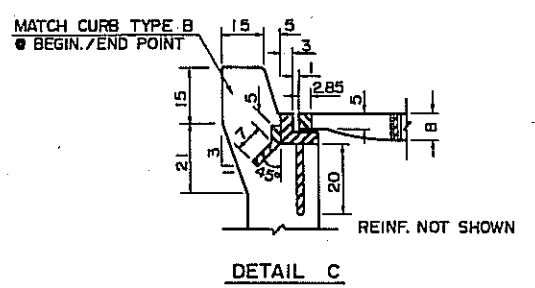
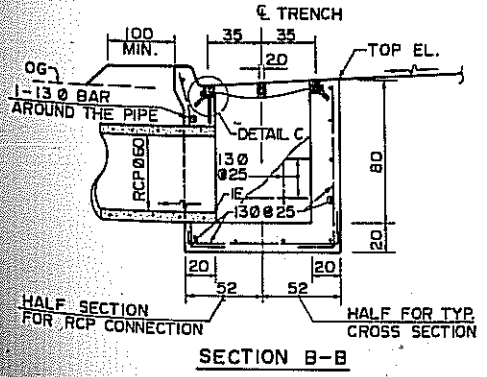
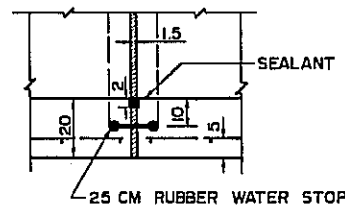
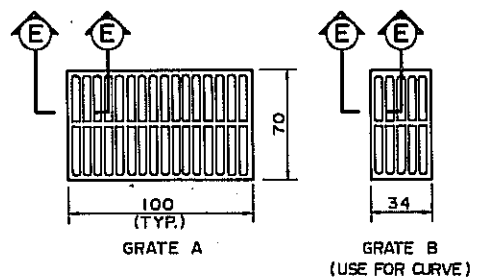
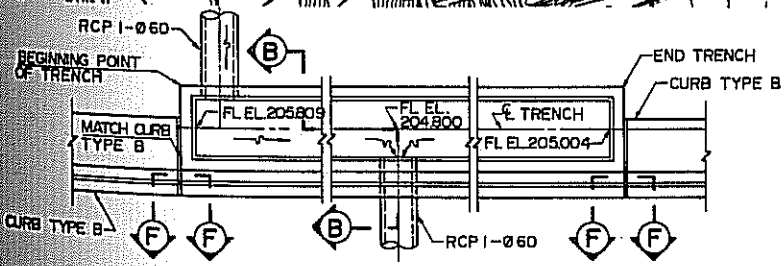

鋼筋混凝土溝 RC TRENCH (NTS)

修正 REVISIONS		項目 ITEM		日期 DATE

交通部台灣區高速公路工程局
TAIWAN AREA FREEWAY CONSTRUCTION BUREAU
中華民國
南北高速公路 NORTH-SOUTH FREEWAY
苗栗台中段 MIAOLI-TAICHUNG SECTION
休憩區排水系統(I) DRAINAGE SYSTEM FOR REST AREA (I)
中華顧問工程司 CHINA ENGINEERING CONSULTANTS, INC.
日期 DATE AUG. '74 比例 SCALE AS SHOWN 圖號 SHEET D-7

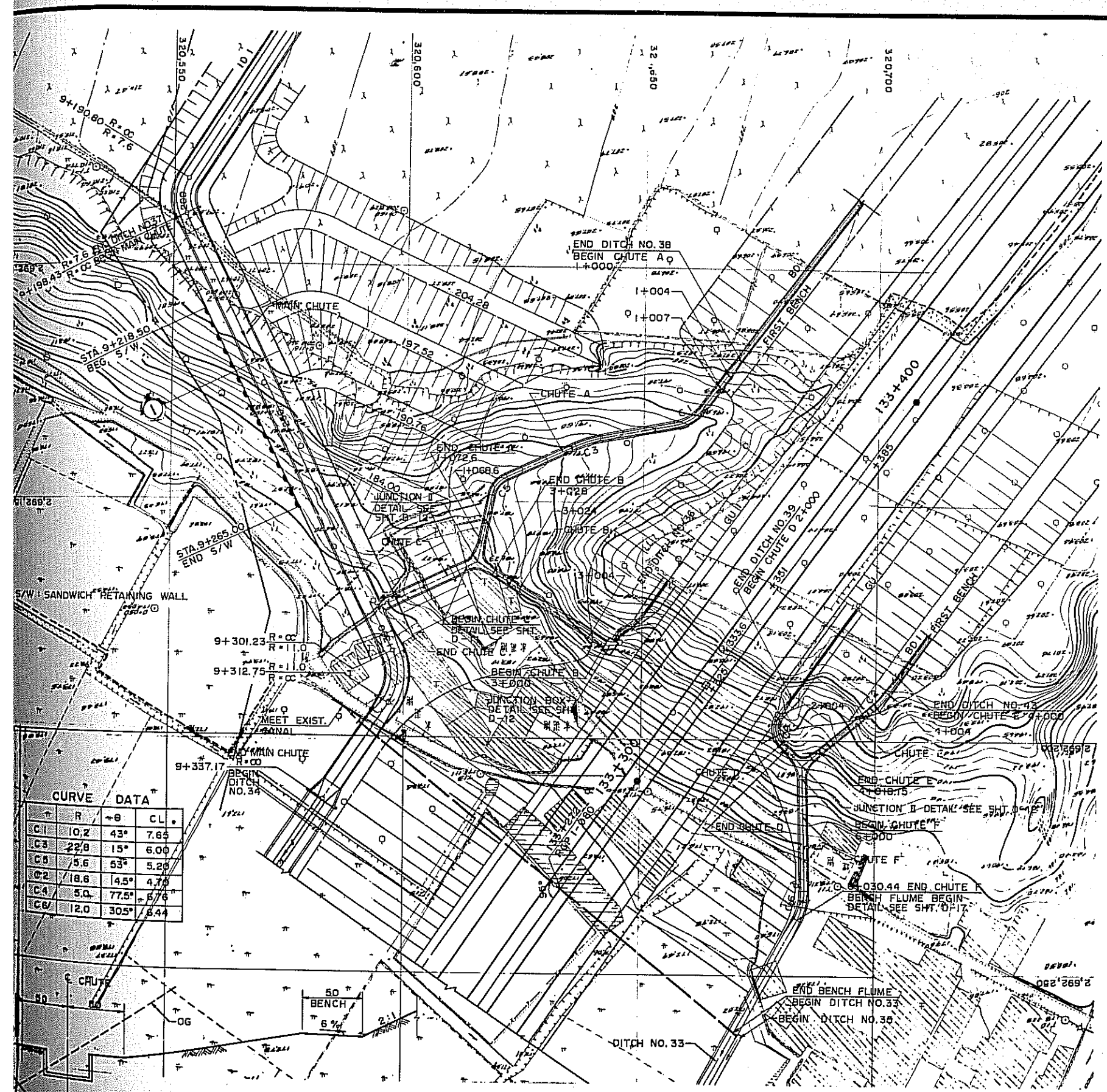

CURVE DATA

CL	R	θ	CL
C1	10.2	43°	7.65
C3	22.8	15°	6.00
C5	5.6	53°	5.26
C2	18.6	145°	4.78
C4	5.0	77.5°	5.75
C6	12.0	305°	5.44

LOCATION MAP
SCALE 1:500

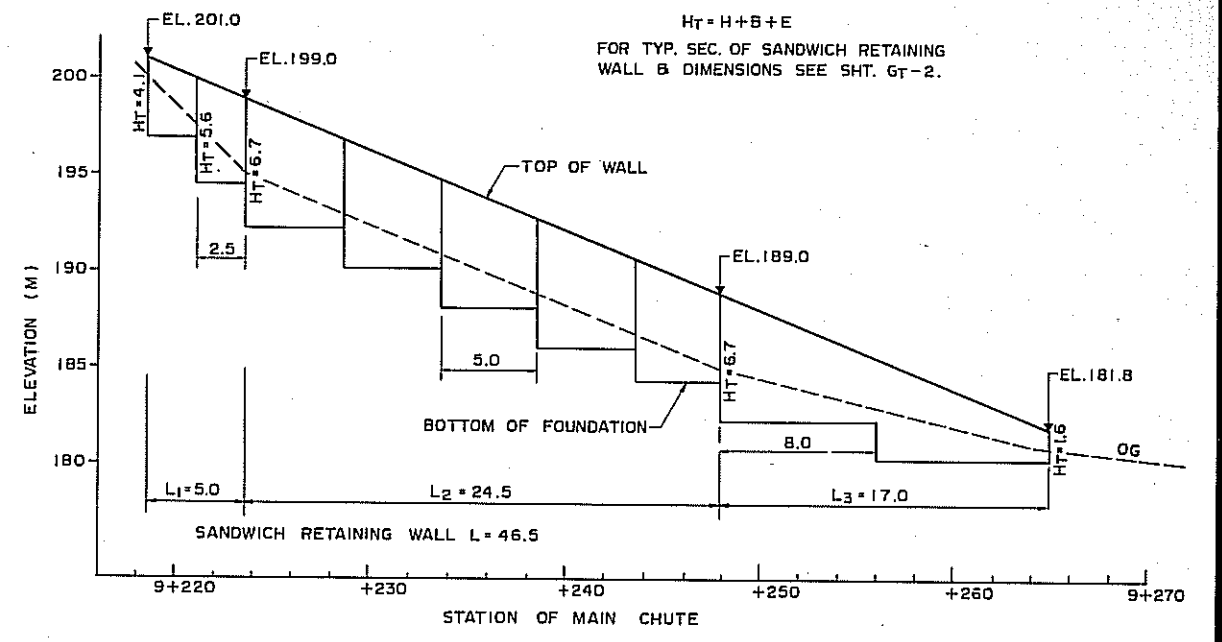

ELEVATION OF SANDWICH RETAINING WALL

DIMENSIONS OF CHUTES

CHUTE	STATION	FL EL.	B	h	Z	DETAILS OF SEC.
A	1+000.00	197.796	0.60	0.55	0.3:1	DITCH NO. 38
	1+004.00	197.700	1.00	0.60	0.5:1	SEE SHT. DT-20.ID 1
	1+007.00	197.700	1.00	0.60	0.5:1	SEE SHT. DT-20.ID 4 *
	1+068.60	181.000	1.00	0.60	0.5:1	SEE SHT. DT-20.ID 4 *
B	3+000.00	188.000	1.00	0.90	0.5:1	SEE SHT. DT-20.ID 1
	3+004.00	188.000	1.00	0.90	0.5:1	SEE SHT. DT-20.ID 4 *
	3+024.00	181.000	1.00	0.90	0.5:1	SEE SHT. DT-20.ID 1
D	2+000.00	188.993	0.50	0.70	1.5:1 3:1	SEE DITCH NO. 39
	2+004.00	188.700	1.00	0.90	0.5:1	SEE SHT. DT-20.ID 4 *
	2+011.50	187.000	1.00	0.90	0.5:1	SEE SHT. DT-20.ID 4 *
E	4+000.00	197.000	0.60	0.55	0.3:1	SEE DITCH NO. 43
	4+004.00	196.500	1.00	0.60	0.5:1	SEE SHT. DT-20.ID 4 *
F	6+000.00	187.000	1.50	1.00	0.5:1	SEE SHT. DT-20.ID 4 *
	6+030.44	173.000	1.50	1.00	0.5:1	SEE SHT. DT-20.ID 4 *

* CONSTRUCT THE CUTOFF WALL AT THE BEGINNING / END POINT AND WITH EVERY 7 M INTERVAL IN THIS

說明：圖中尺寸除另有註明者外，單位均以公尺計。

NOTE: ALL DIMENSIONS SHOWN ARE IN METERS UNLESS OTHERWISE NOTED

修正 REVISIONS	項目 ITEM	日期 DATE

PROJECT 60

交通部台灣區高速公路工程局
TAIWAN AREA FREEWAY CONSTRUCTION BUREAU
中華民國
南北高速公路 NORTH-SOUTH FREEWAY
苗栗台中段 MIAOLI-TAICHUNG SECTION

休養區排水系統(II) DRAINAGE SYSTEM
FOR REST AREA (II)

中華顧問工程司 CHINA ENGINEERING CONSULTANTS, INC.
日期 DATE AUG '74 比例 SCALE AS SHOWN 圖號 SHEET D-8

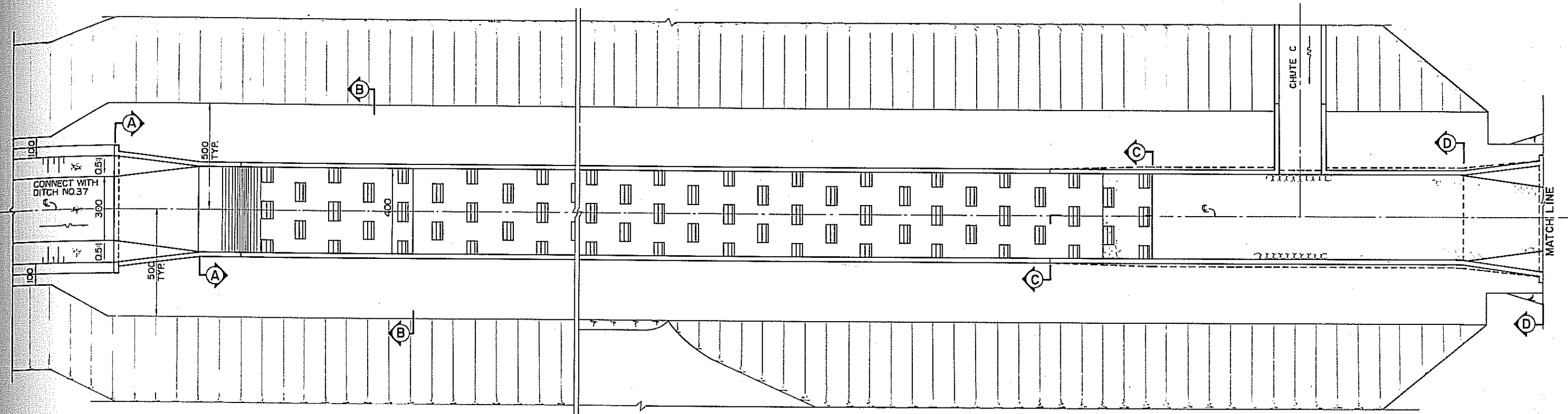

PLAN

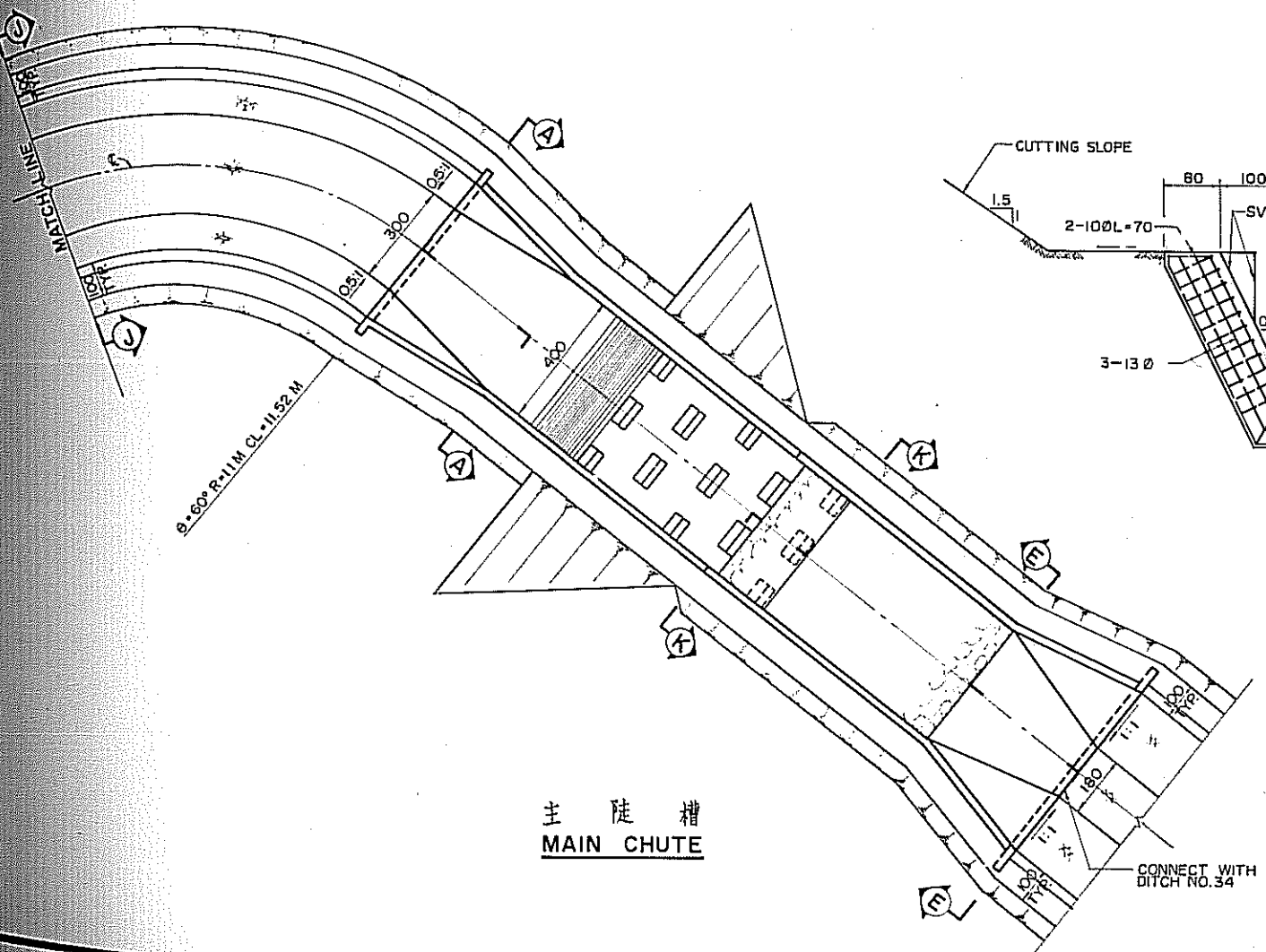

主陸槽
MAIN CHUTE

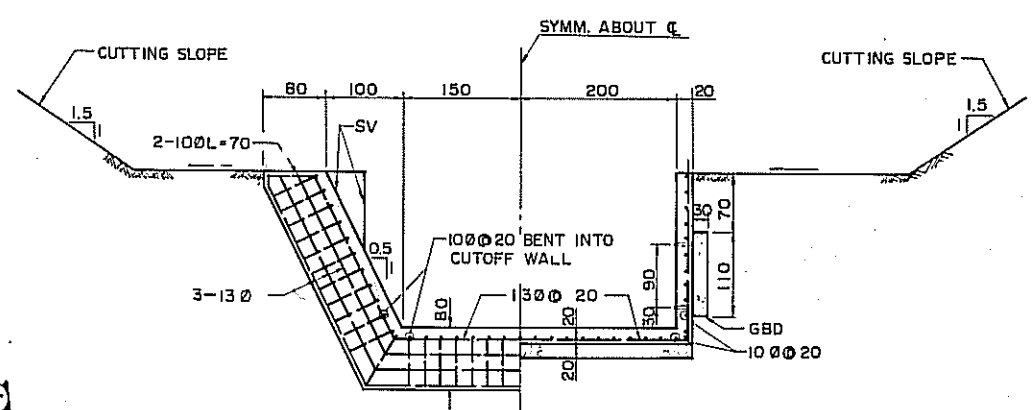

SECTION A-A

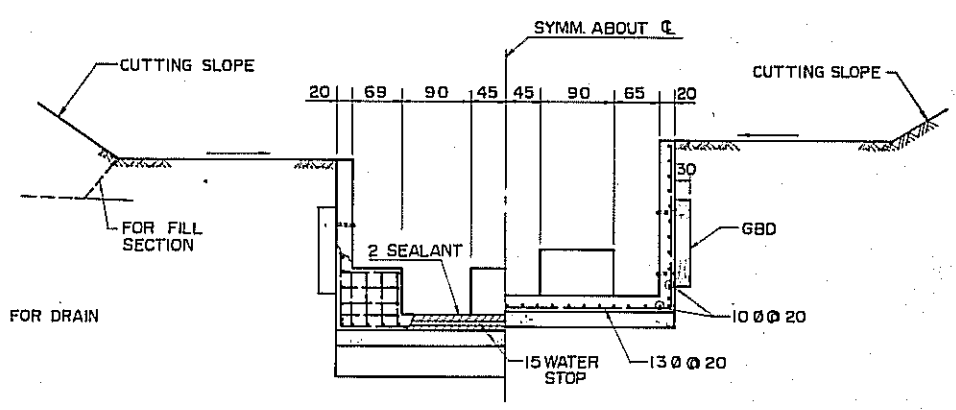

SECTION B-B

FOR SECTION C-C, D-D, E-E, AND LONGITUDINAL SECTION SEE SHT. D-10.
FOR SECTION J-J & K-K SEE SHT. D-11.
SV INDICATES THE SIDE SLOPE OF TRANSITION WALLS VARIED FROM UPSTREAM TO DOWNSTREAM.

GBD: GRAVEL BACKFILL FOR DRAIN

修正 項目	REVISIONS ITEM	日期 DATE

PROJECT 60
交通部台灣區高速公路工程局
TAIWAN AREA FREEWAY CONSTRUCTION BUREAU
中華民國
REPUBLIC OF CHINA
南北高速公路 NORTH-SOUTH FREEWAY
苗栗台中段 MIAOLI-TAICHUNG SECTION
休憩區排水系統(III) DRAINAGE SYSTEM
FOR REST AREA (III)
中華顧問工程司 CHINA ENGINEERING CONSULTANTS, INC.
日期 DATE AUG. '74 比例 SCALE NTS 圖號 SHEET D-9

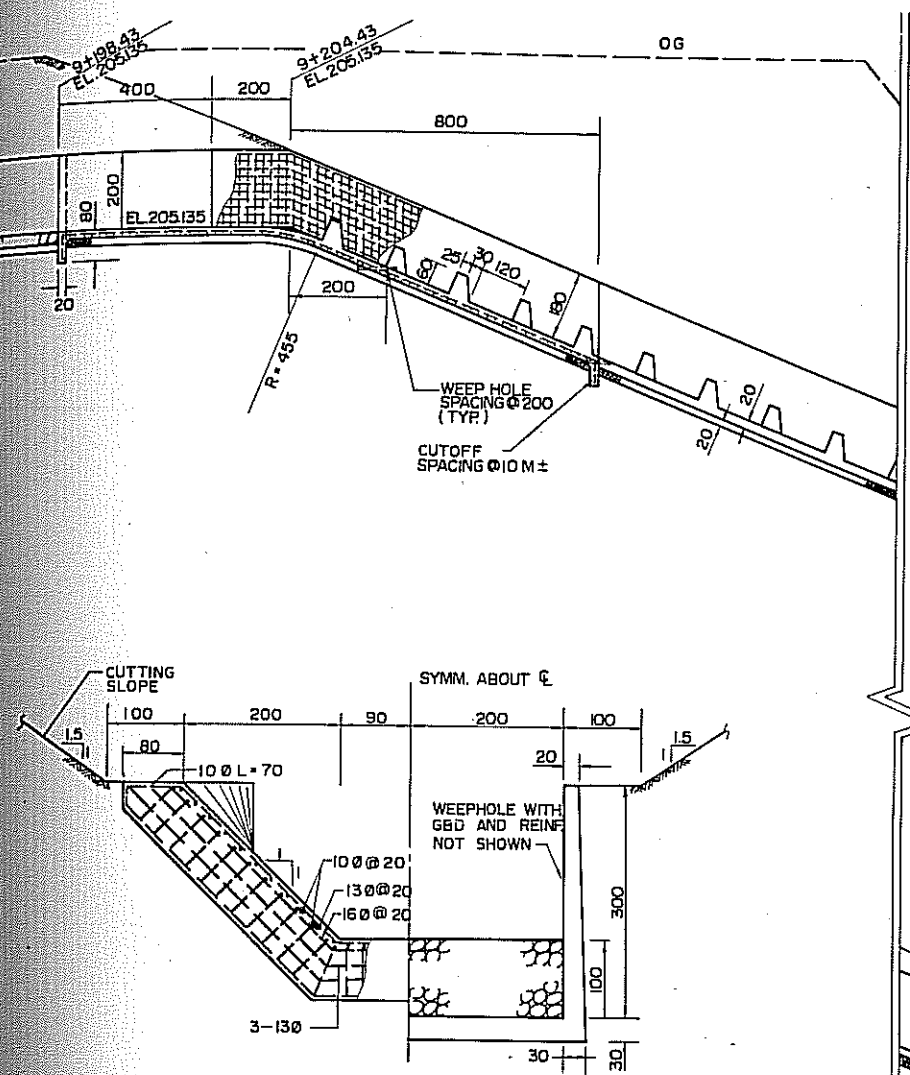

SECTION E-E

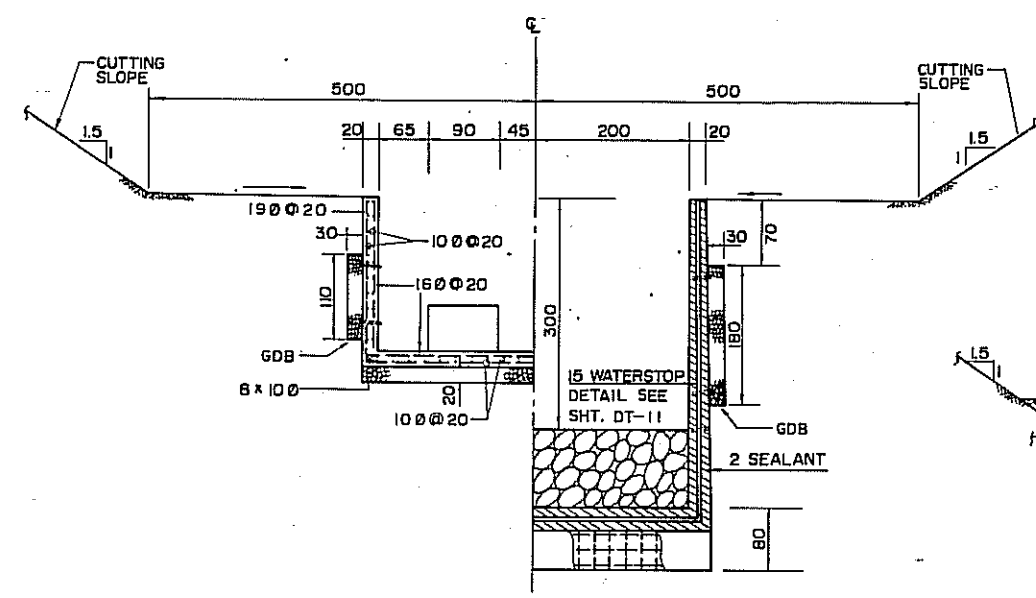

SECTION C-C

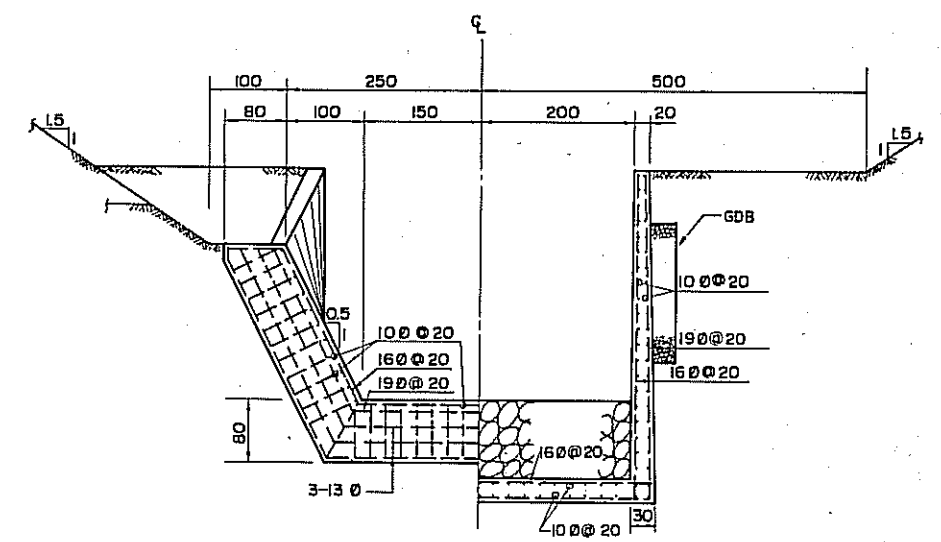

SECTION D-D

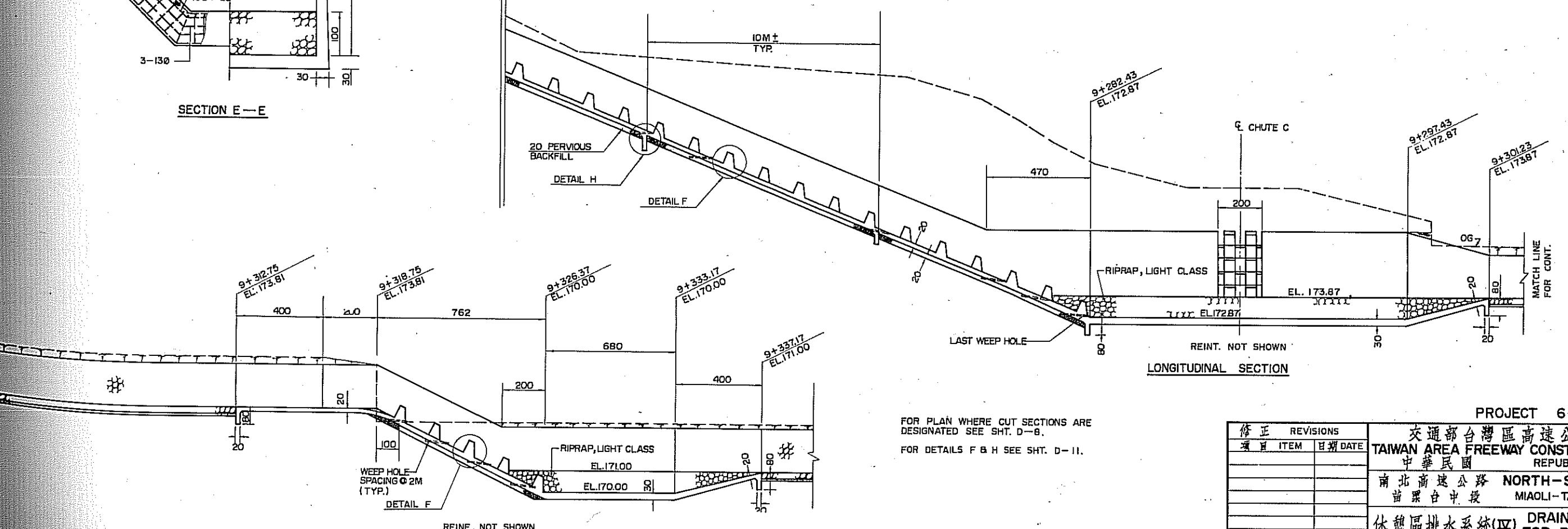

LONGITUDINAL SECTION

FOR PLAN WHERE CUT SECTIONS ARE DESIGNATED SEE SHT. D-8.
FOR DETAILS F & H SEE SHT. D-11.

PROJECT 60

修正	REVISIONS	項目	ITEM	日期	DATE

交通部台灣區高速公路工程局
TAIWAN AREA FREEWAY CONSTRUCTION BUREAU
中華民國
REPUBLIC OF CHINA
南北高速公路 NORTH-SOUTH FREEWAY
苗栗台中段 MIAOLI-TAICHUNG SECTION
休憩區排水系統(IV) DRAINAGE SYSTEM
FOR REST AREA (IV)
中華顧問工程司 CHINA ENGINEERING CONSULTANTS, INC.
日期 DATE AUG '74 比例 SCALE NTS 圖號 SHEET D-10

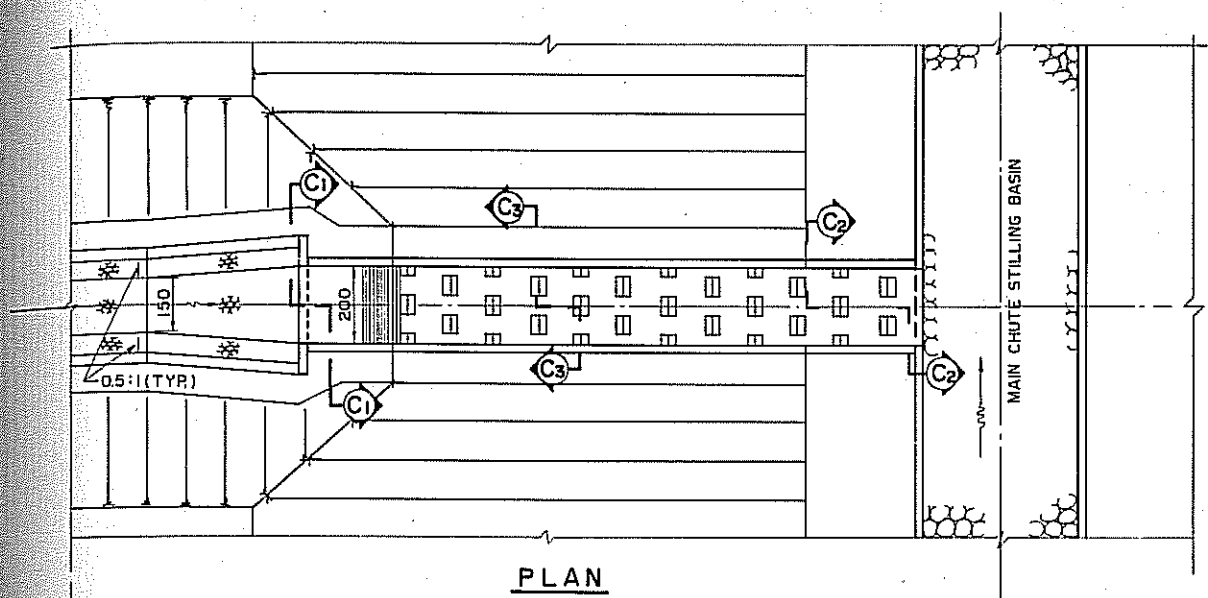

PLAN

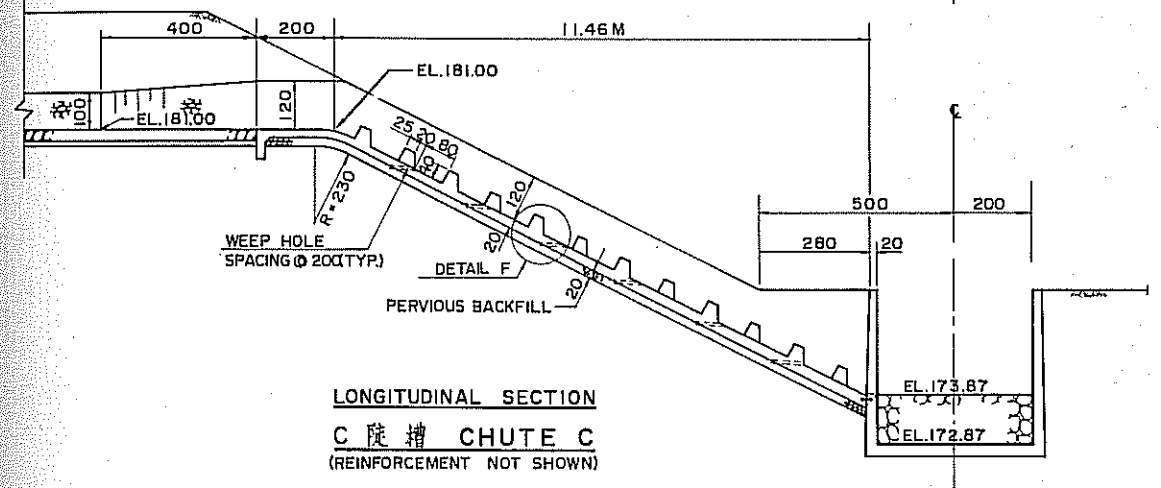

LONGITUDINAL SECTION
C 陡槽 CHUTE C
(REINFORCEMENT NOT SHOWN)

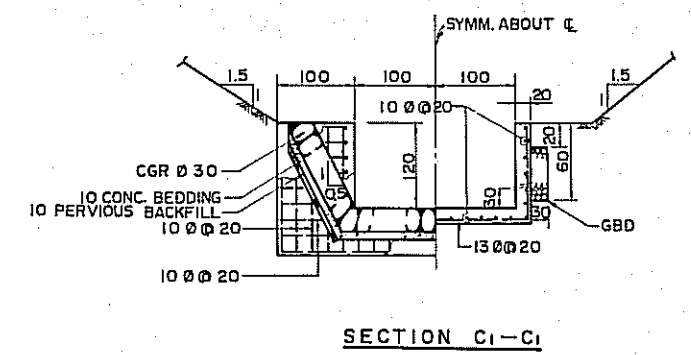

SECTION C1-C1

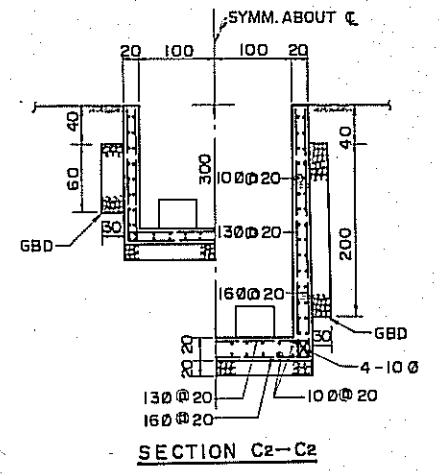

SECTION C2-C2

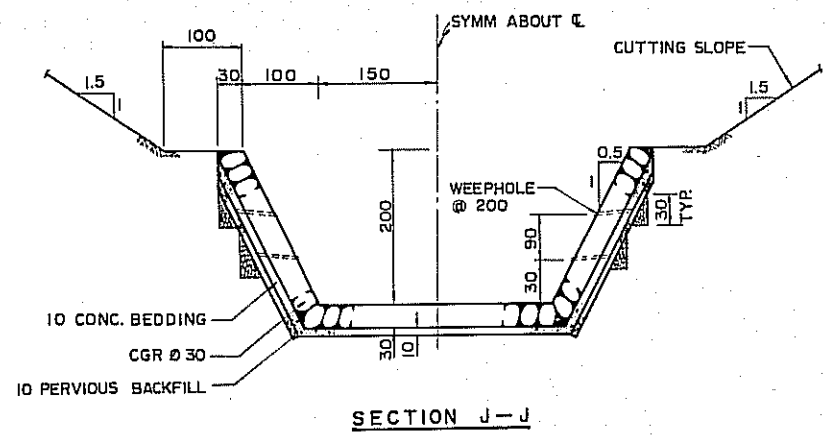

SECTION J-J

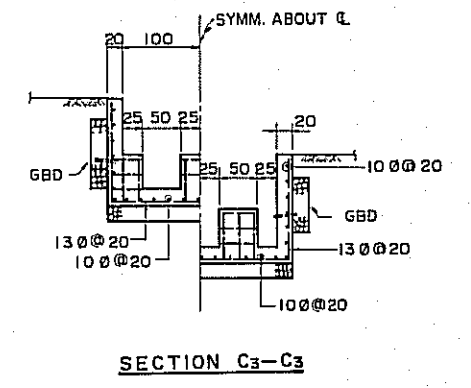

SECTION C3-C3

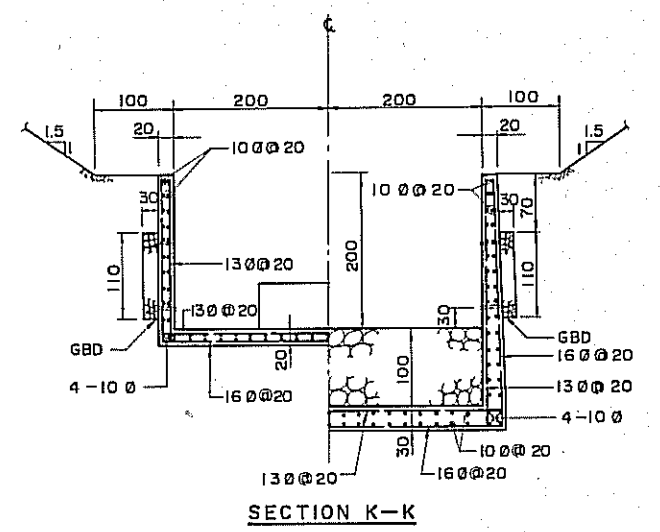

SECTION K-K

FOR PLAN WHERE SECTIONS J-J & K-K CUTTED SEE SHT. D-9

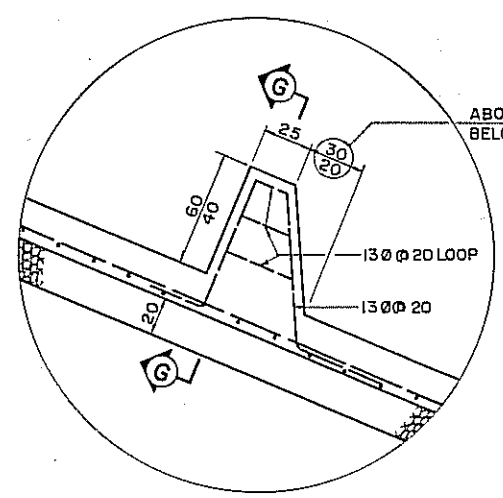

DETAIL F

ABOVE FIGURE FOR MAIN CHUTE
BELOW FIGURE FOR CHUTE C

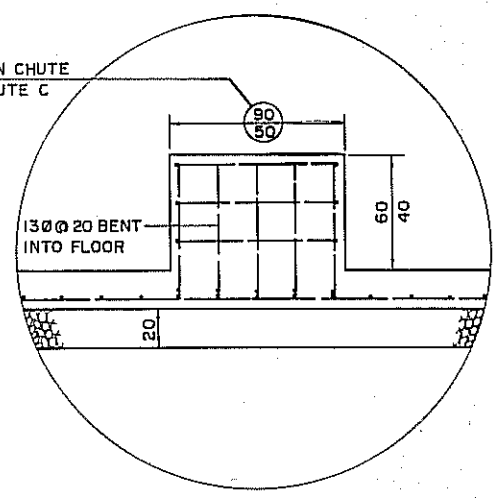

SECTION G-G

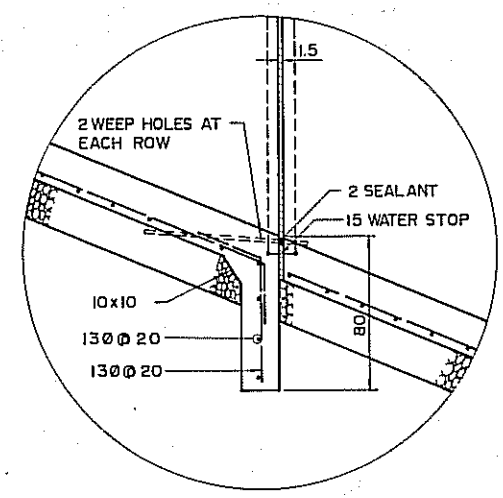

DETAIL H

PROJECT 60

修正 REVISIONS	項目 ITEM	日期 DATE	交通部台灣區高速公路工程局 TAIWAN AREA FREEWAY CONSTRUCTION BUREAU 中華民國 REPUBLIC OF CHINA
			南北高速公路 NORTH-SOUTH FREEWAY 苗栗台中段 MIAOLI-TAICHUNG SECTION
			休憩區排水系統(Ⅴ) DRAINAGE SYSTEM FOR REST AREA (Ⅴ)
			中華顧問工程司 CHINA ENGINEERING CONSULTANTS, INC. 日期 DATE AUG. '74 比例 SCALE NTS 圖號 APPENDIX D-11

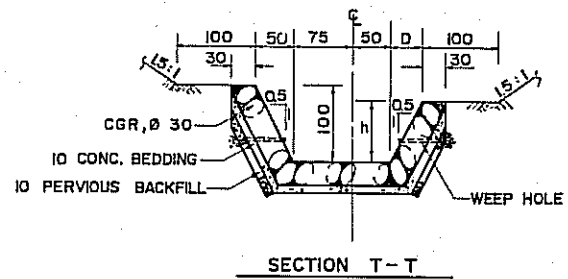
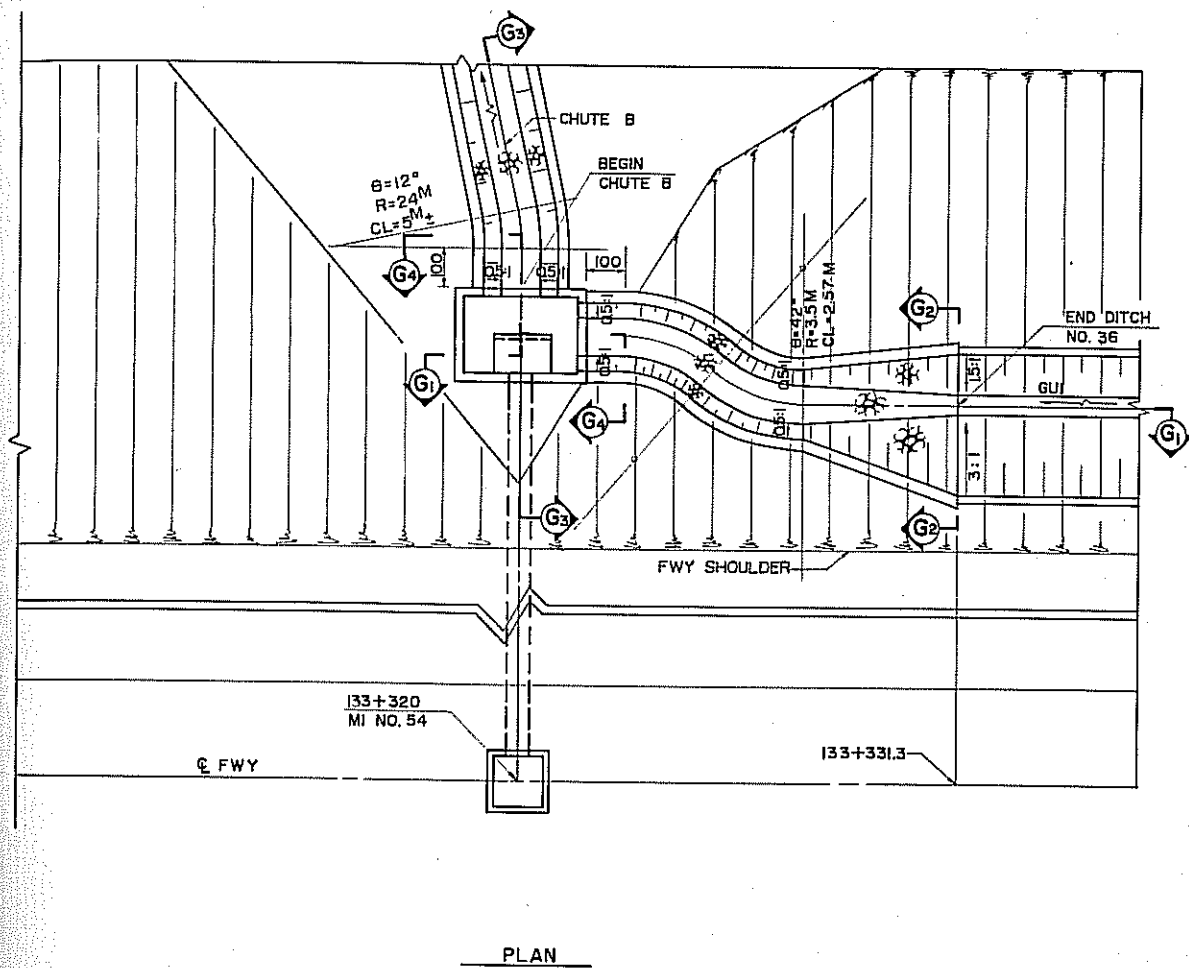

CGR: CONCRETE GROUTED ROCK

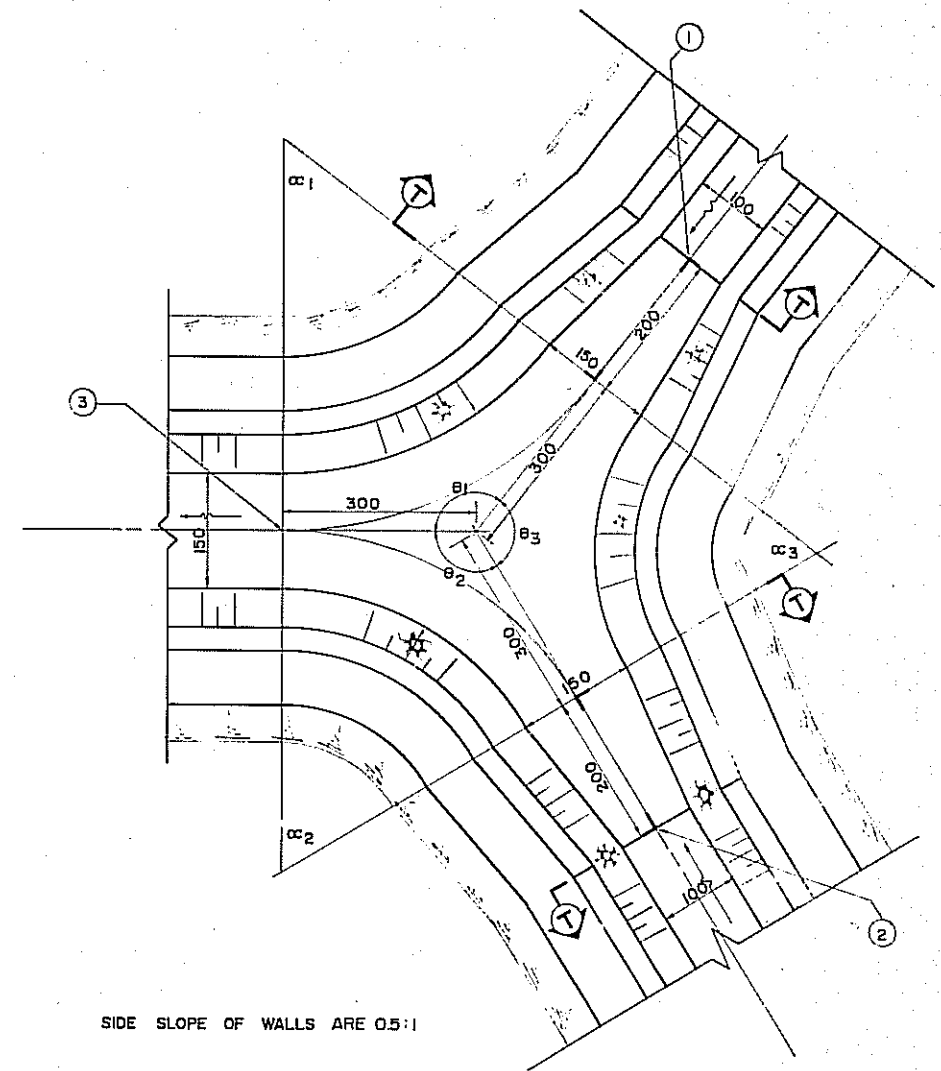
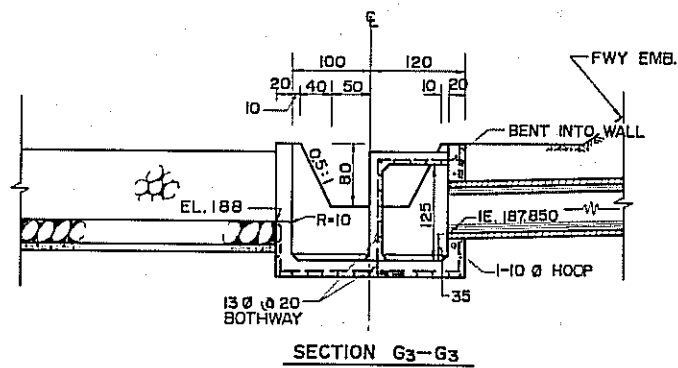
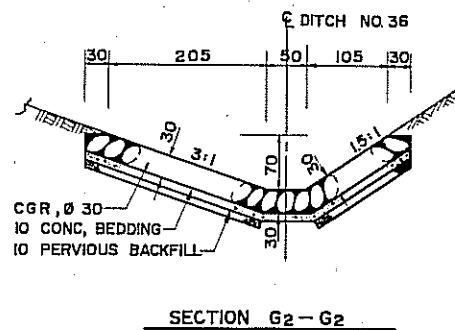

JUNCTION	θ ₁	θ ₂	θ ₃	DITCH HEIGHT h (CM)			CURVE DATA			
				(1)	(2)	(3)	θ	R (M)	CL (M)	
I	127.5°	122°	110.5°	60	90	100	α ₁	52.5*	4.3	3.94
				CHUTE A	CHUTE B	CHUTE C	α ₂	58*	3.8	3.85
							α ₃	69.5*	3.0	3.64
II	140°	128°	92°	90	60	100	α ₁	40*	7.6	5.31
				CHUTE D	CHUTE E	CHUTE F	α ₂	52*	5.8	2.26
							α ₃	88*	2.8	4.30

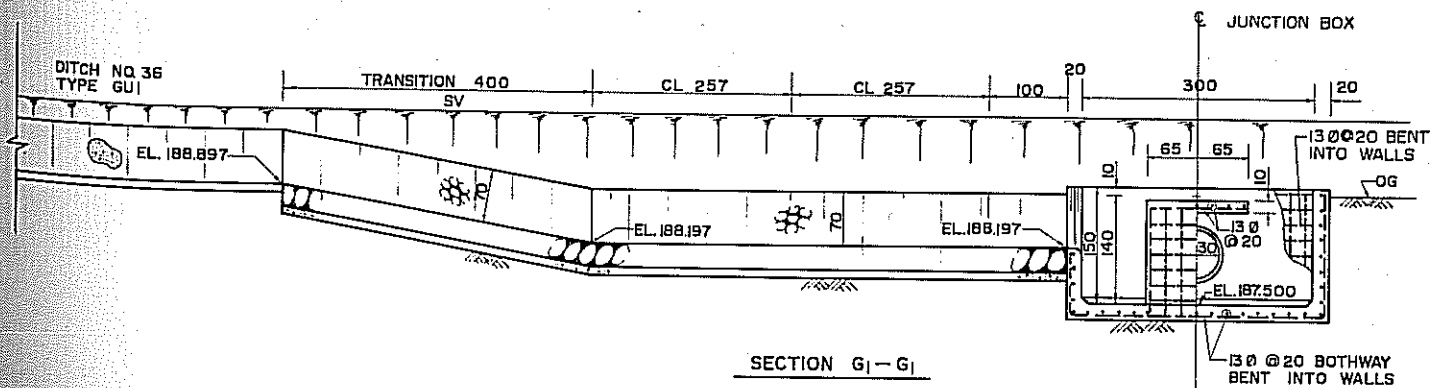

匯流箱
JUNCTION BOX

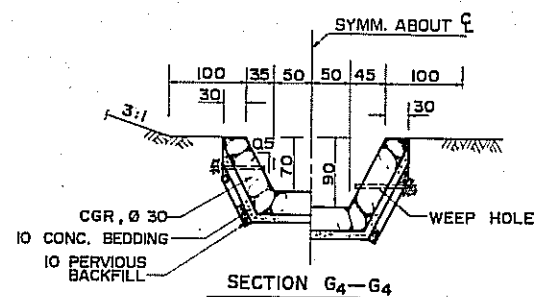

PROJECT 60

修正	REVISIONS	項目	ITEM	日期	DATE

交通部台灣區高速公路工程局
TAIWAN AREA FREEWAY CONSTRUCTION BUREAU
中華民國
REPUBLIC OF CHINA
南北高速公路 NORTH-SOUTH FREEWAY
苗栗台中段 MIAOLI-TAICHUNG SECTION
休憩區排水系統(VI) DRAINAGE SYSTEM
FOR REST AREA (VI)
中華顧問工程司 CHINA ENGINEERING CONSULTANTS, INC.
日期 DATE AUG '74 比例 SCALE NT\$ 圖號 SHEET D-12

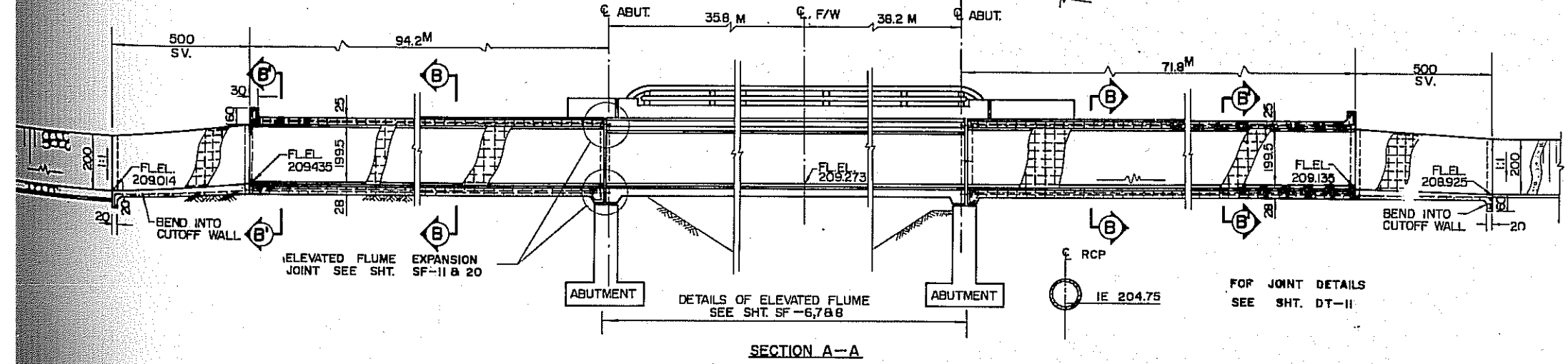
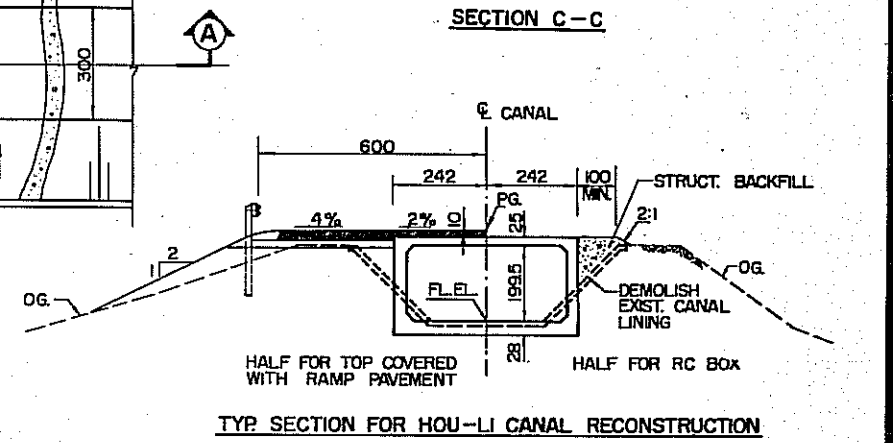
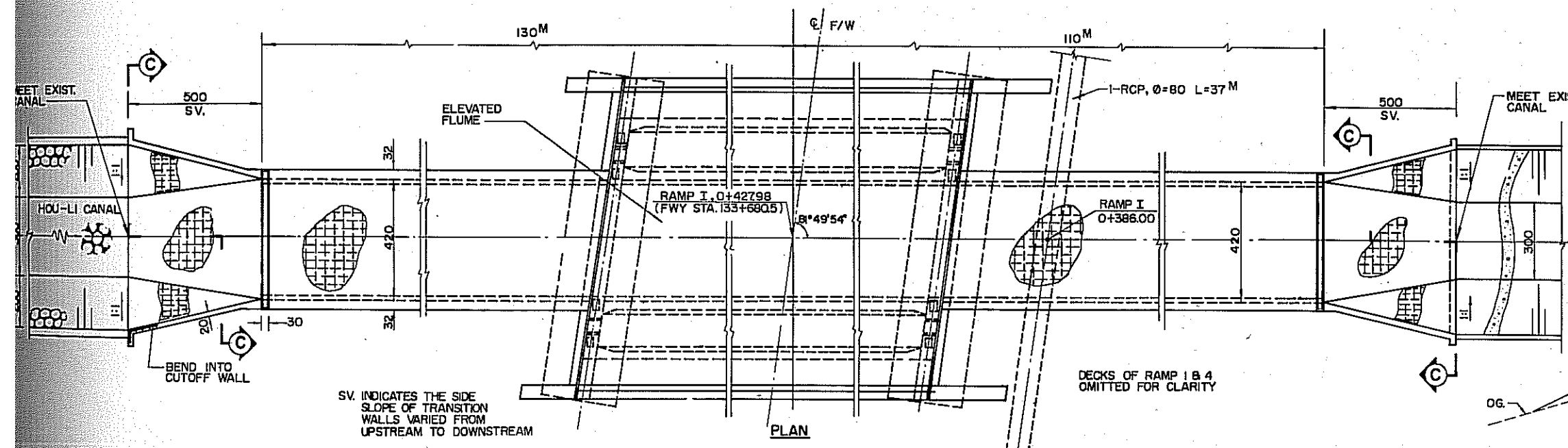
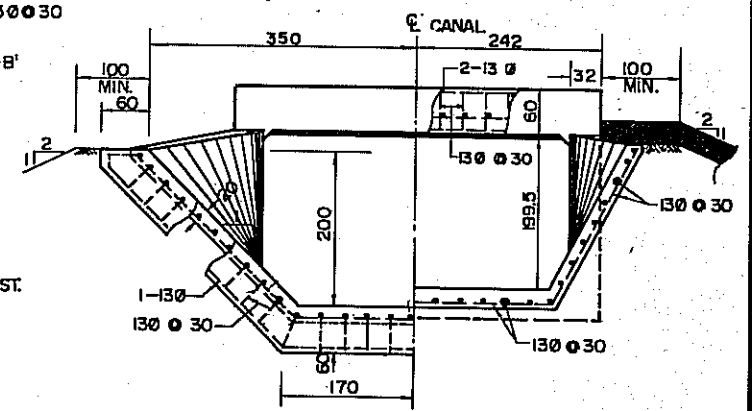
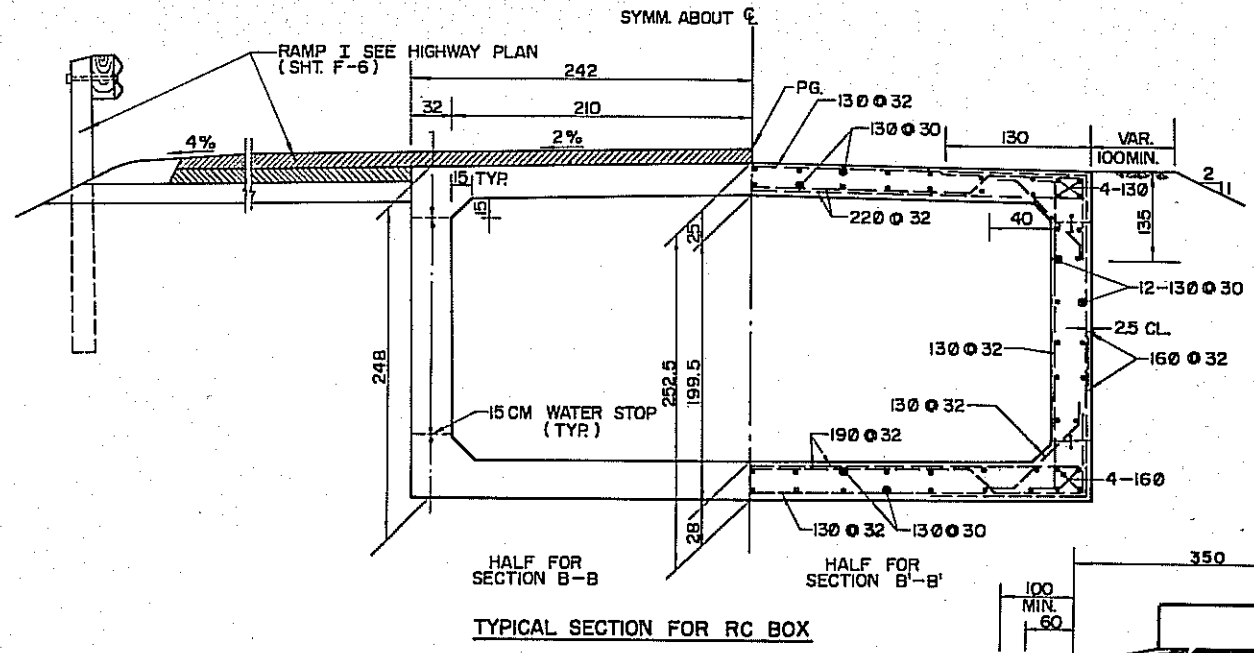
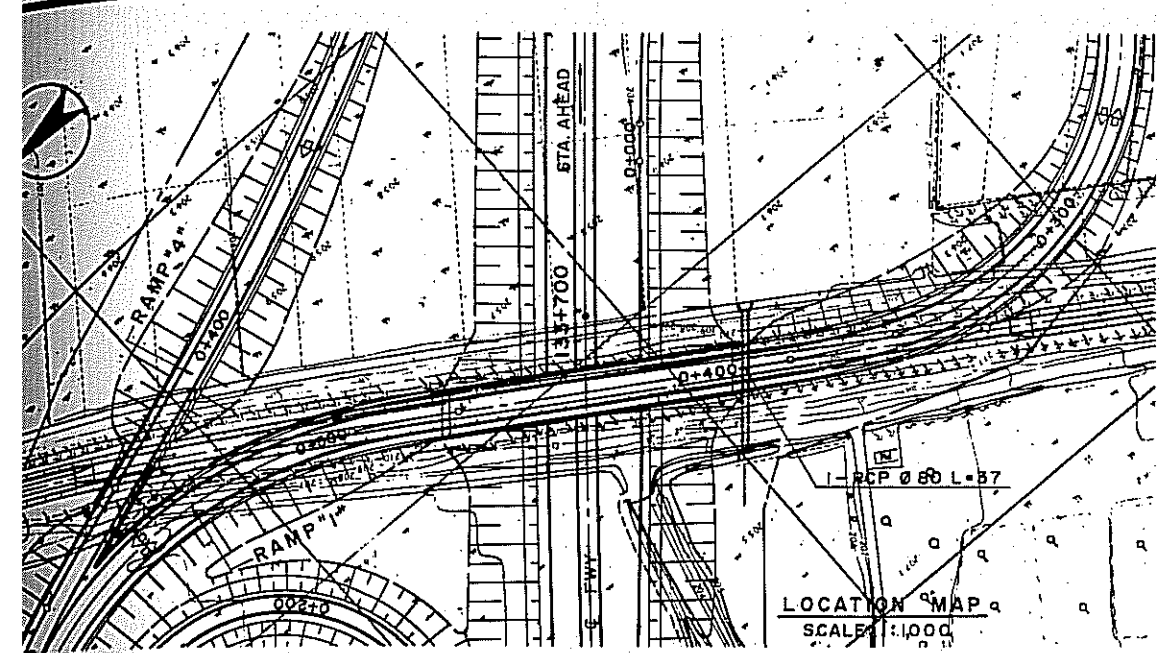

后里圳重建
HOULI CANAL RECONSTRUCTION

修正 REVISIONS		項目 ITEM		日期 DATE	

PROJECT 60
交通部台灣區高速公路工程局
TAIWAN AREA FREEWAY CONSTRUCTION BUREAU
中華民國
REPUBLIC OF CHINA
南北高速公路 NORTH-SOUTH FREEWAY
苗栗台中段 MIAOLI-TAICHUNG SECTION
后里圳重建 HOULI CANAL RECONSTRUCTION
中華顧問工程司 CHINA ENGINEERING CONSULTANTS, INC.
日期 DATE AUG. '74 比例 SCALE NTS 圖號 SHEET D-13

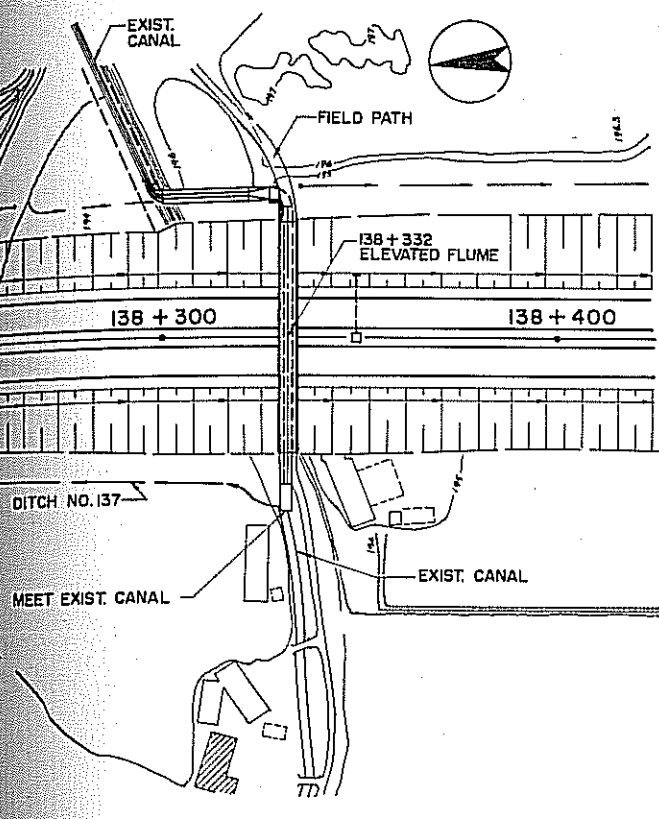

LOCATION MAP
SCALE 1:1000

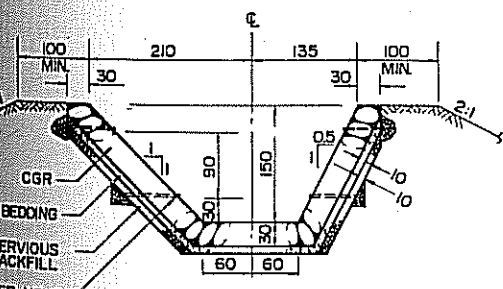

SECTION B-B

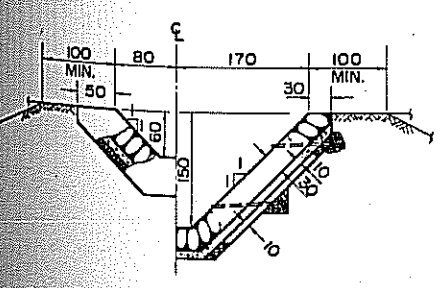

SECTION L-L

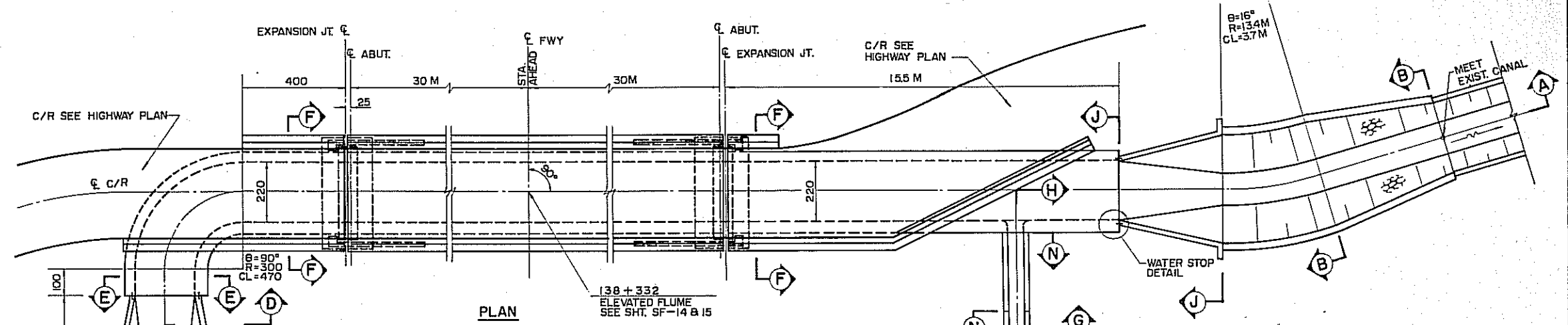

PLAN

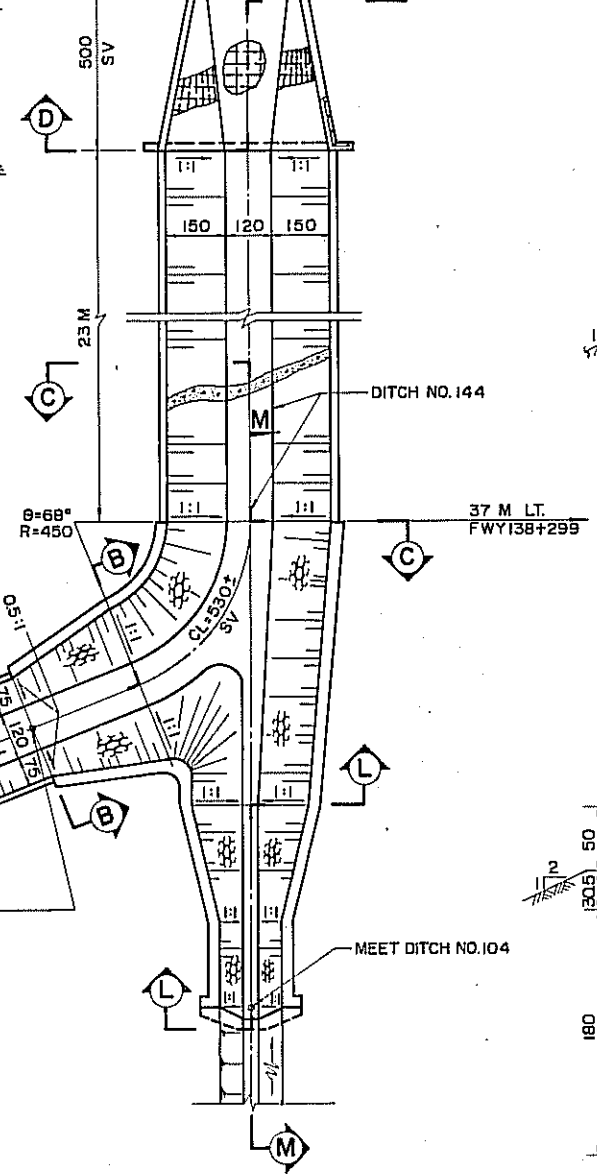

SV INDICATES THE SIDE SLOPE OF TRANSITION WALL VARIED FROM UPSTREAM TO DOWNSTREAM.
CGR INDICATES THE CONCRETE GROUTED ROCK, Ø 30

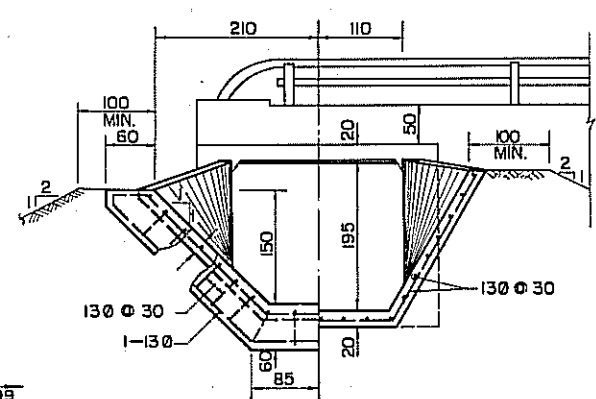

SECTION D-D

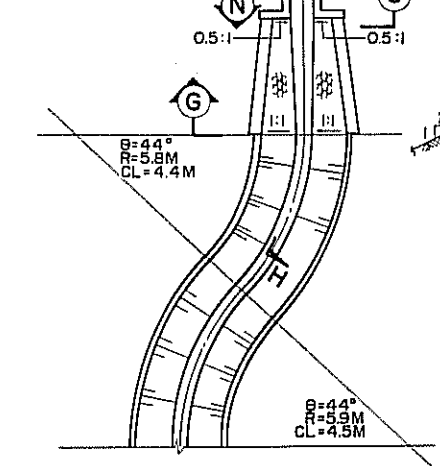

SECTION E-E

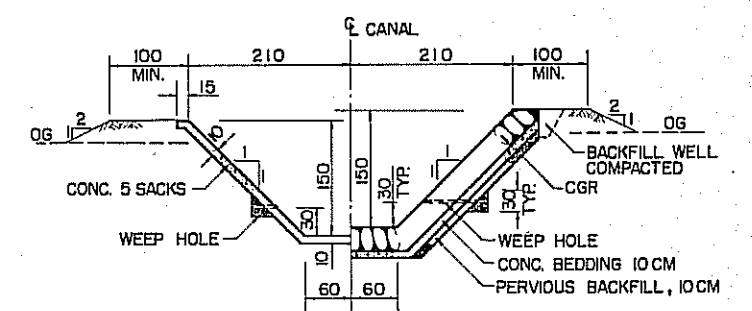

SECTION C-C

FOR SECTIONS A-A, H-H, M-M, N-N, G-G, J-J AND WATER STOP DETAIL SEE SHT. D-14B

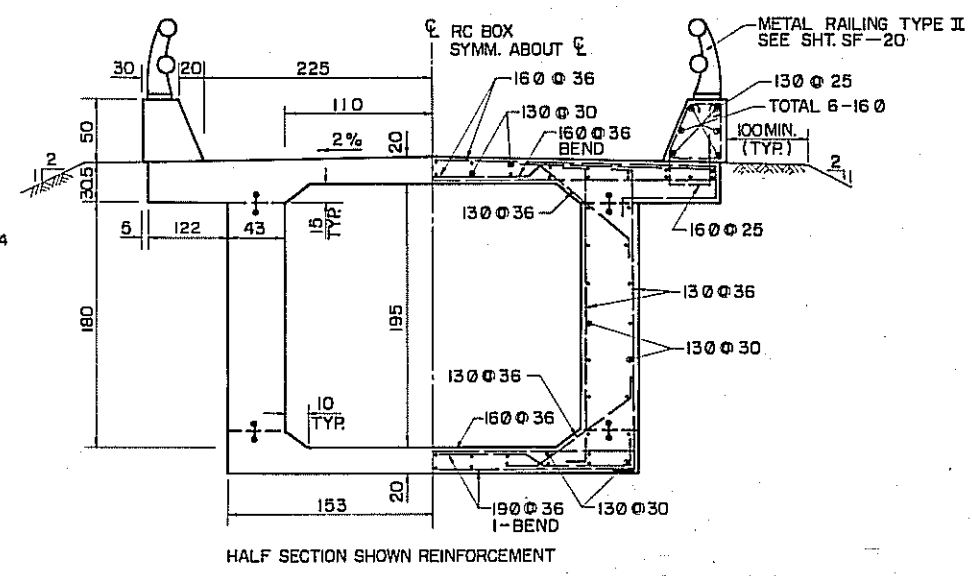

SECTION F-F

HALF SECTION SHOWN REINFORCEMENT

修正	REVISIONS	項目	ITEM	日期	DATE

PROJECT 60
交通部台灣區高速公路工程局
TAIWAN AREA FREEWAY CONSTRUCTION BUREAU
中華民國
REPUBLIC OF CHINA
南北高速公路
NORTH-SOUTH FREEWAY
苗栗台中段
MIAOLI-TAICHUNG SECTION
波槽進口及出口
INLET/OUTLET OF ELEVATED FLUME @ 138 + 332
中華顧問工程司
CHINA ENGINEERING CONSULTANTS, INC.
日期 DATE AUG. 74' 比例 SCALE NTS 圖號 SHEET D-14A

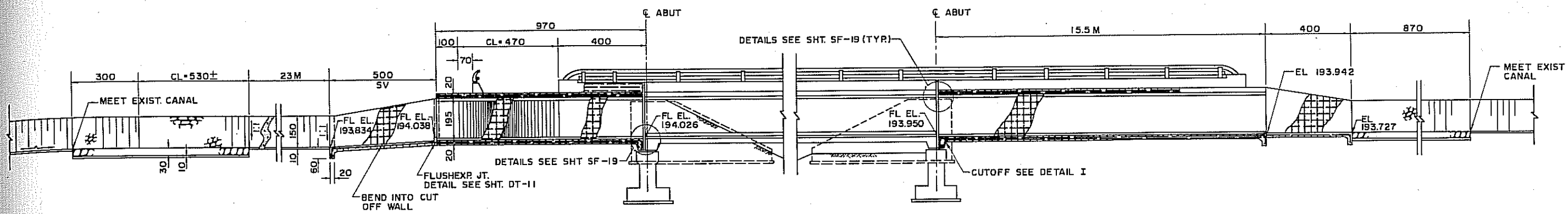

SECTION A-A

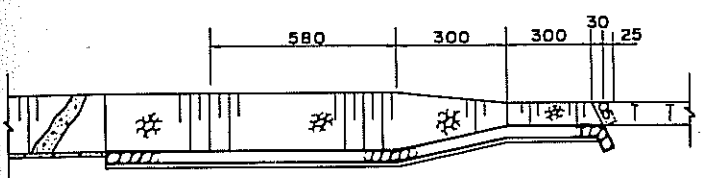

SECTION M-M

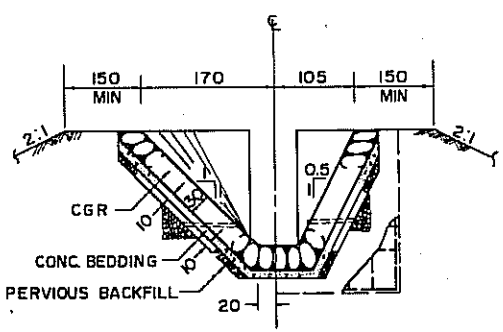

SECTION G-G

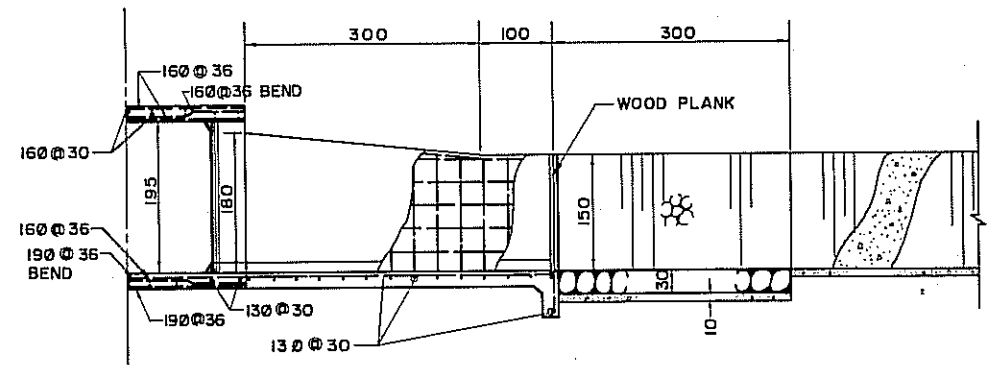

SECTION H-H

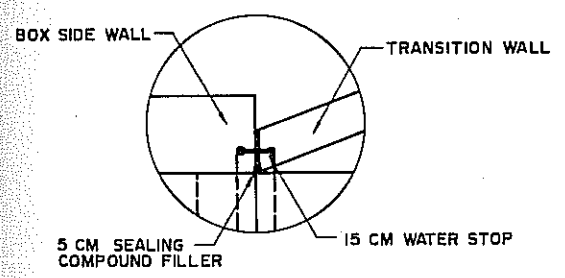

DETAIL W

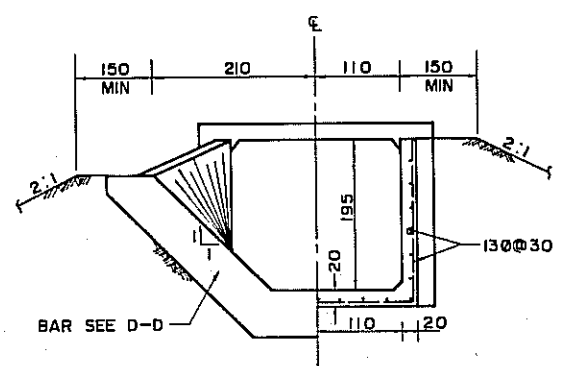

SECTION J-J

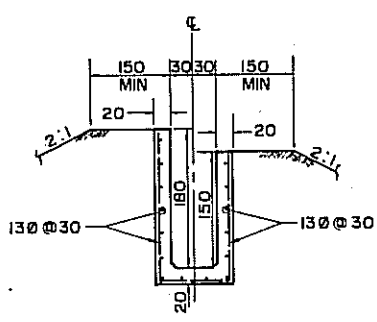

SECTION N-N

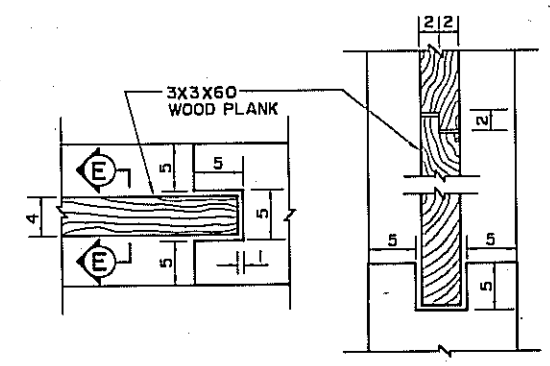

PLAN SECTION E-E

WOOD PLANK DETAILS

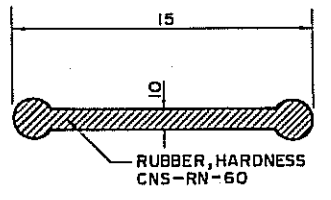

15 CM WATERSTOP

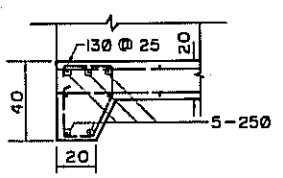

DETAIL I

PROJECT 60

修正	REVISIONS	交通部台灣區高速公路工程局
項目	ITEM	TAIWAN AREA FREEWAY CONSTRUCTION BUREAU
日期	DATE	中華民國
		REPUBLIC OF CHINA
		南北高速公路 NORTH-SOUTH FREEWAY
		苗栗台中段 MIAOLI-TAICHUNG SECTION
		渡槽進口及出口 INLET/OUTLET OF ELEVATED
		FLUME @ 138+332
		中華顧問工程司 CHINA ENGINEERING CONSULTANTS, INC.
		日期 DATE AUG '74 比例 SCALE NTS 圖號 SHEET D-14 B

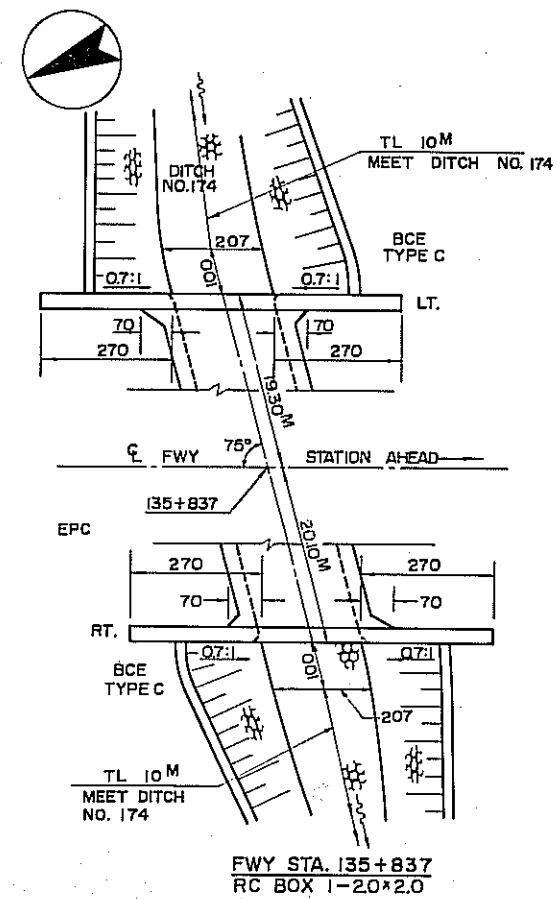
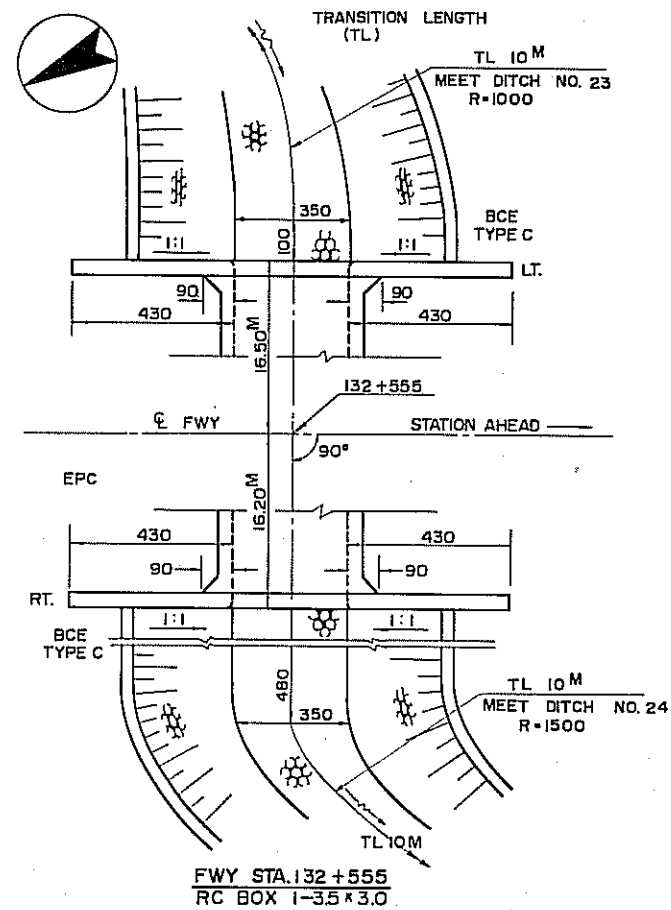
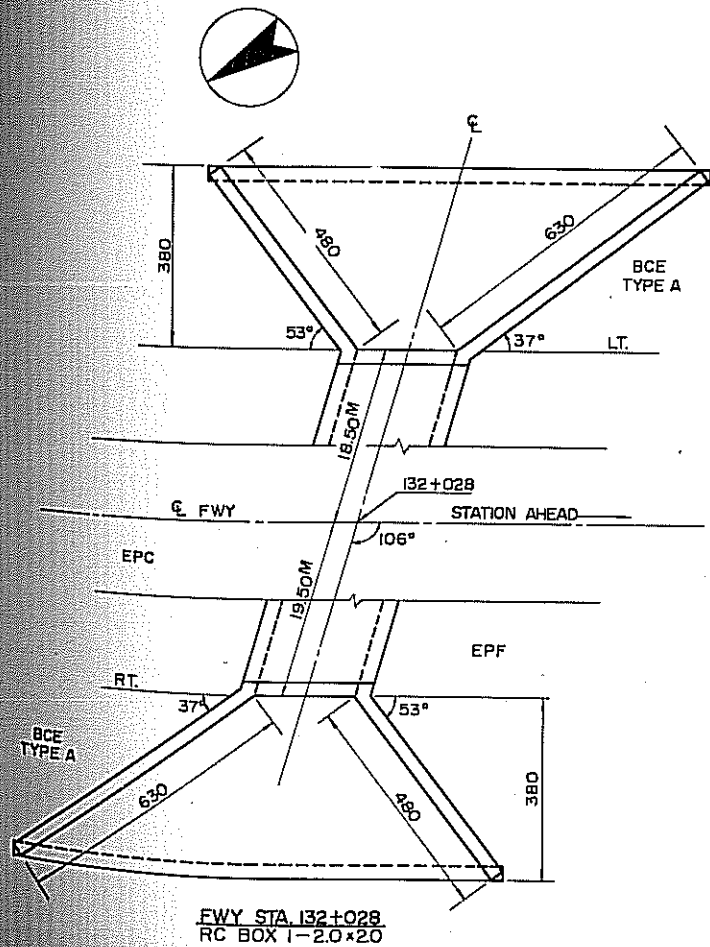
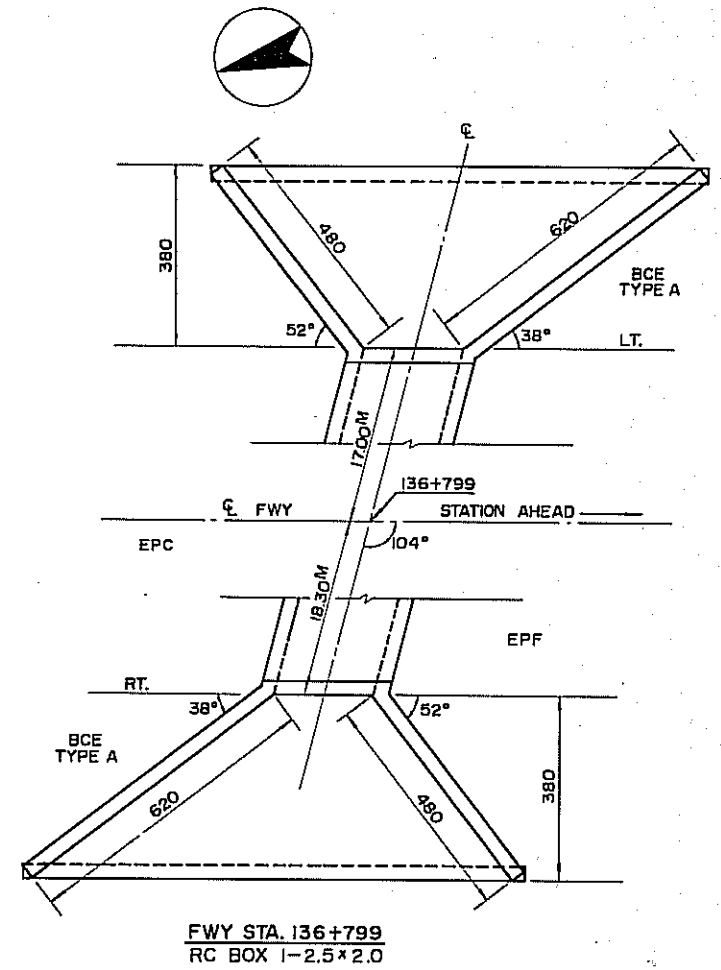
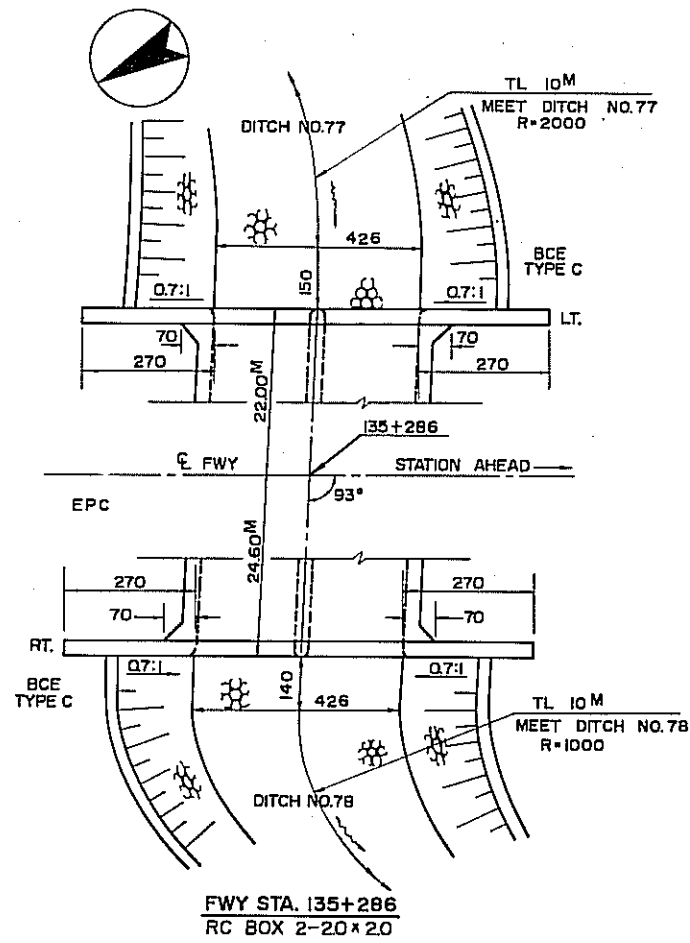
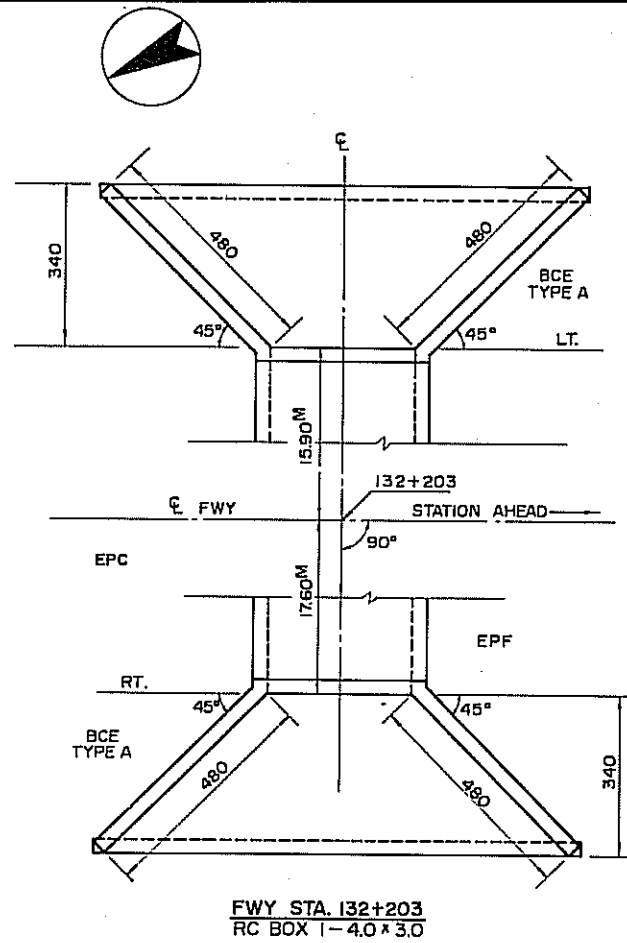
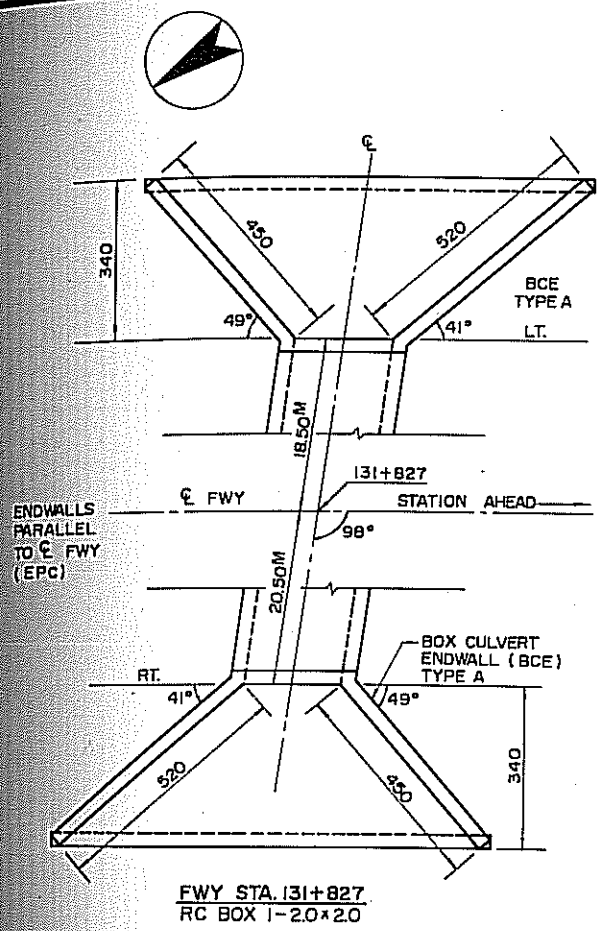

說明:

- 箱涵進口及出口溝底高程以及上下游間之明溝尺寸等，請參閱圖 D-1~D-6
- 箱涵之詳細設計請參閱圖 DT-8~DT-13。

NOTES:

- FOR THE IE OF BOX CULVERTS AND DITCH SIZE SEE SH. D-1~D-6
- FOR THE DETAILS OF BOX CULVERTS SEE SH. DT-8~DT-13.

PROJECT 60

修正 REVISIONS	項目 ITEM	日期 DATE

交通部台灣區高速公路工程局
TAIWAN AREA FREEWAY CONSTRUCTION BUREAU
中華民國
REPUBLIC OF CHINA
南北高速公路 NORTH-SOUTH FREEWAY
苗栗台中段 MIAOLI-TAICHUNG SECTION
箱涵進出口處理(I) RC BOX END LAYOUT(I)
中華顧問工程司 CHINA ENGINEERING CONSULTANTS, INC.

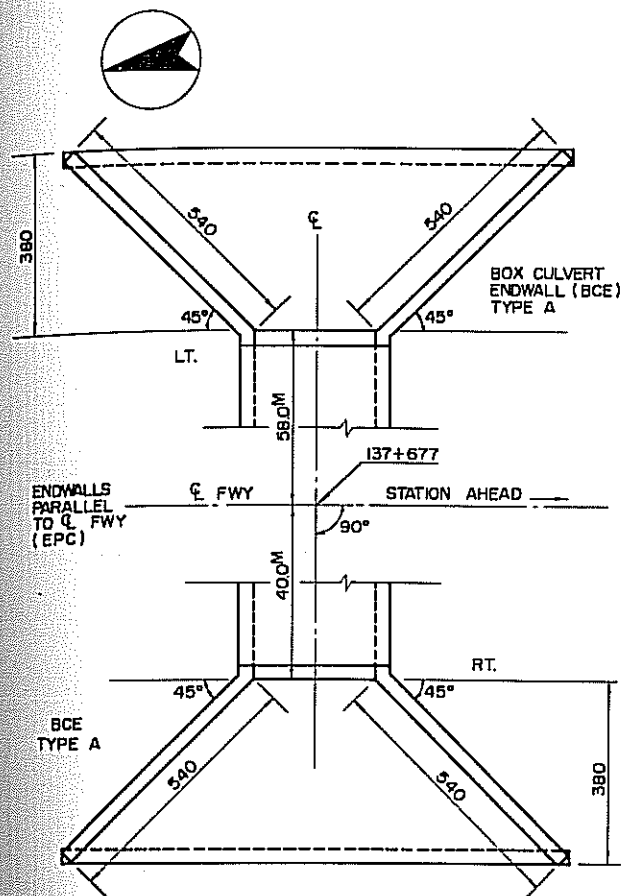

FWY STA. 137+677
RC BOX 1-2.5x2.0

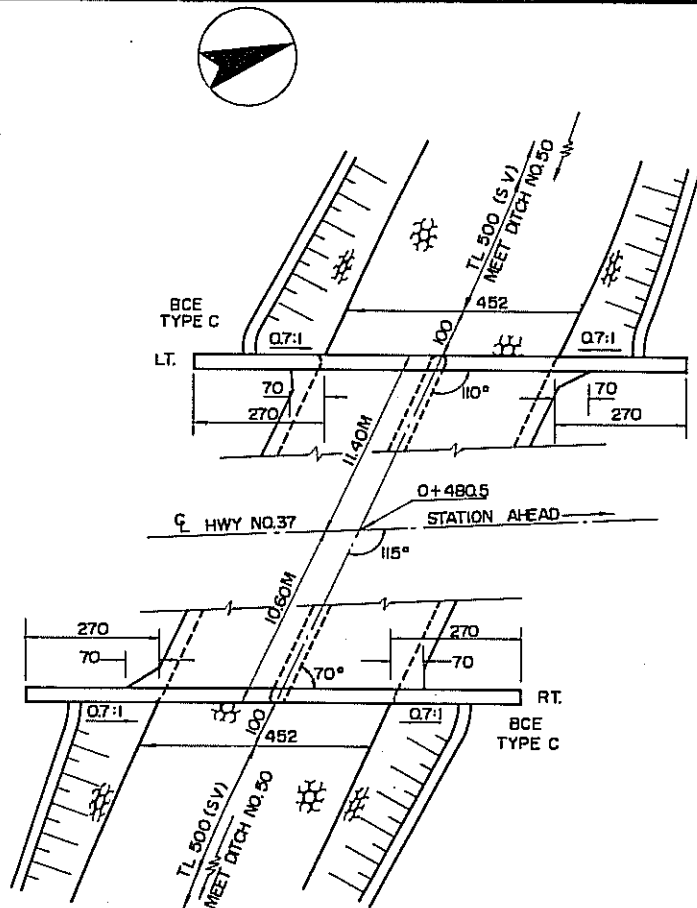

HWY NO. 37 STA. 0+480.5
RC BOX 2-2.0x1.7

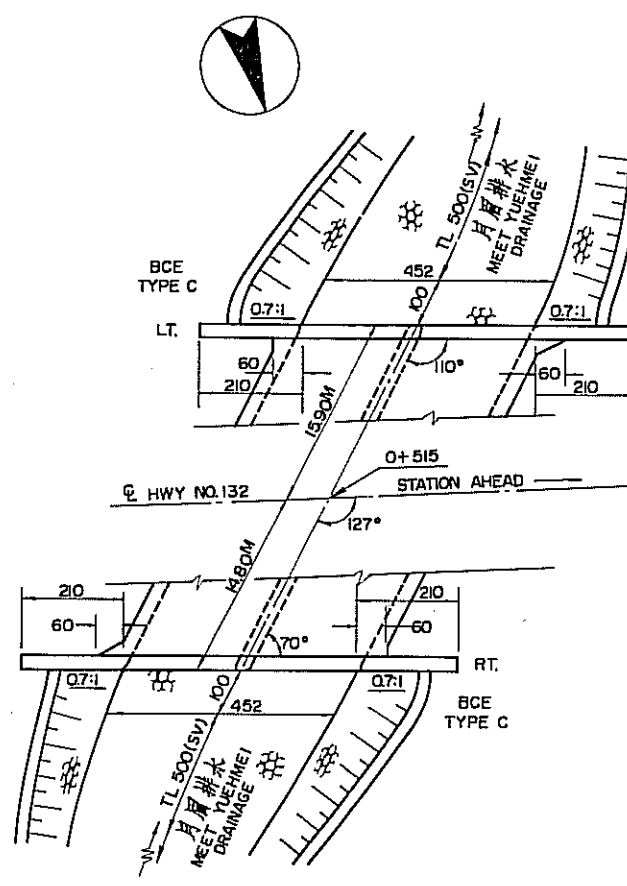

HWY NO. 132 STA. 0+515
RC BOX 2-2.0x1.5

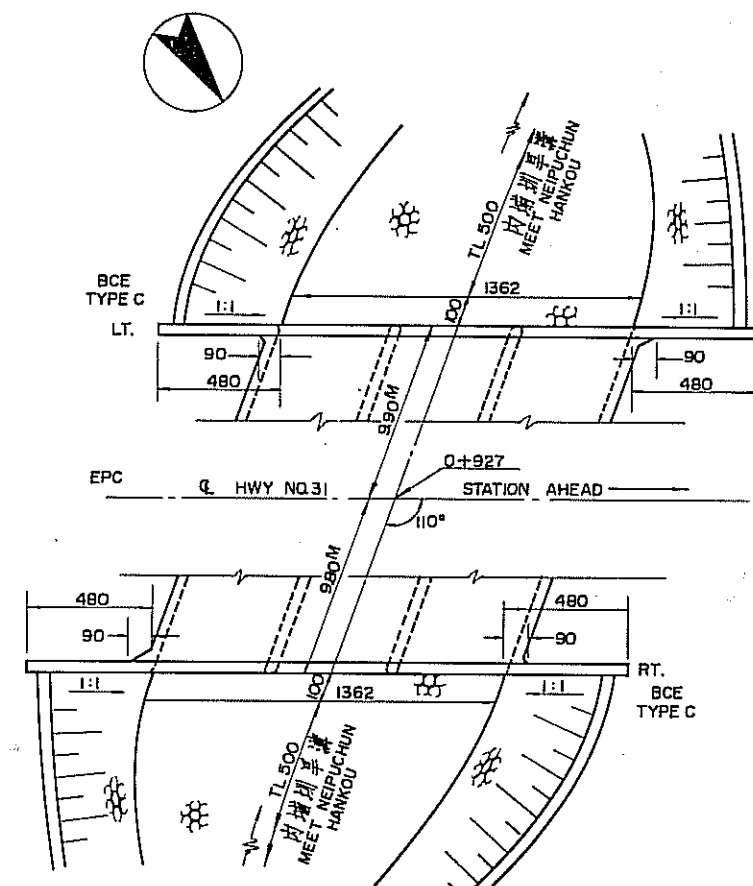

HWY NO. 31 STA. 0+927
RC BOX 3-4.0x3.0

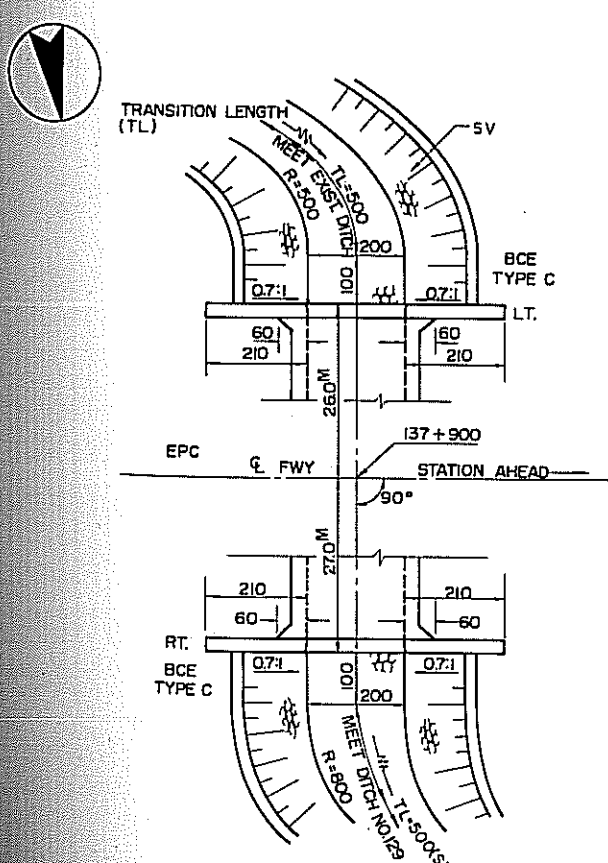

FWY STA. 137+900
RC BOX 1-2.0x1.5

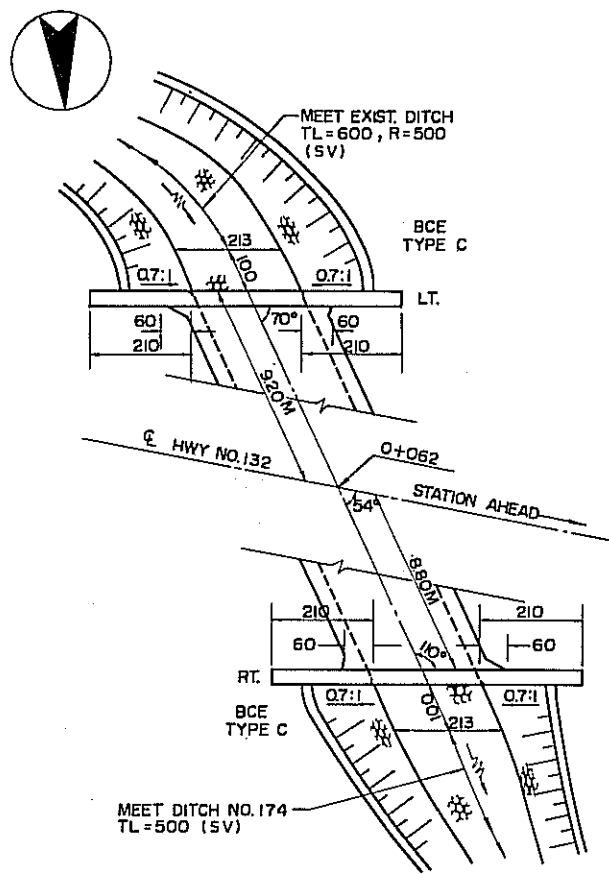

HWY NO. 132 STA. 0+062
RC BOX 1-2.0x1.5

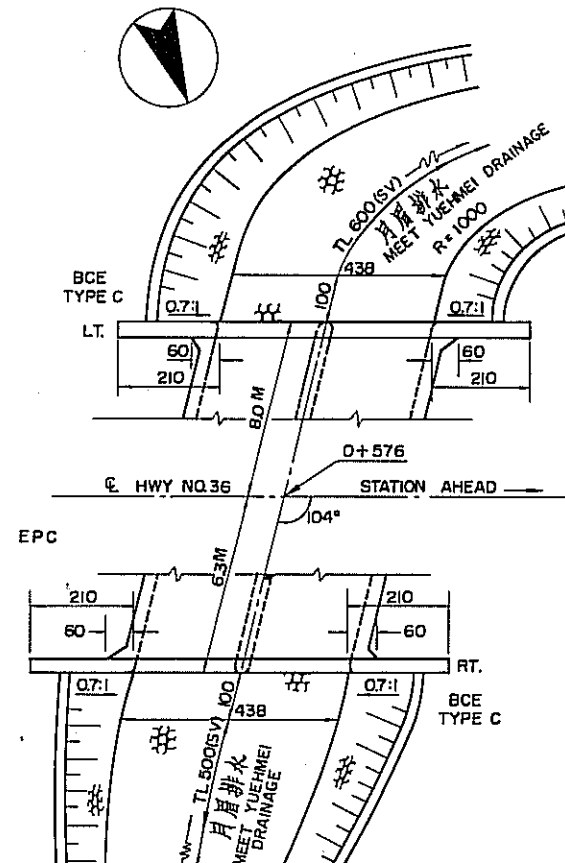

HWY NO. 36 STA. 0+576
RC-BOX 2-2.0x1.5

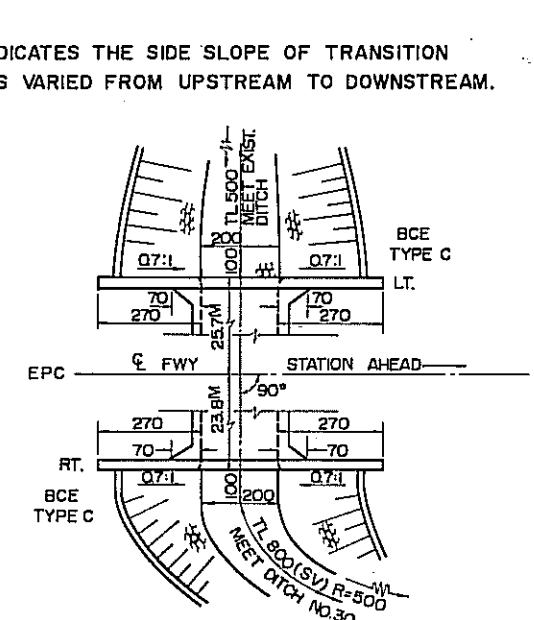

FWY STA. 132+823
RC BOX 1-2.0x2.0

SV INDICATES THE SIDE SLOPE OF TRANSITION WALLS VARIED FROM UPSTREAM TO DOWNSTREAM.

PROJECT 60

修正	REVISIONS	項目	ITEM	日期	DATE

交通部台灣區高速公路工程局
TAIWAN AREA FREEWAY CONSTRUCTION BUREAU
中華民國
REPUBLIC OF CHINA
南北高速公路
NORTH-SOUTH FREEWAY
苗栗台中段
MIAOLI-TAICHUNG SECTION
箱涵進出口處理(II) RC BOX END LAYOUT (II)
中華顧問工程司
CHINA ENGINEERING CONSULTANTS, INC.
日期 DATE AUG '74 比例 SCALE NT5 圖號 SHEET D-16

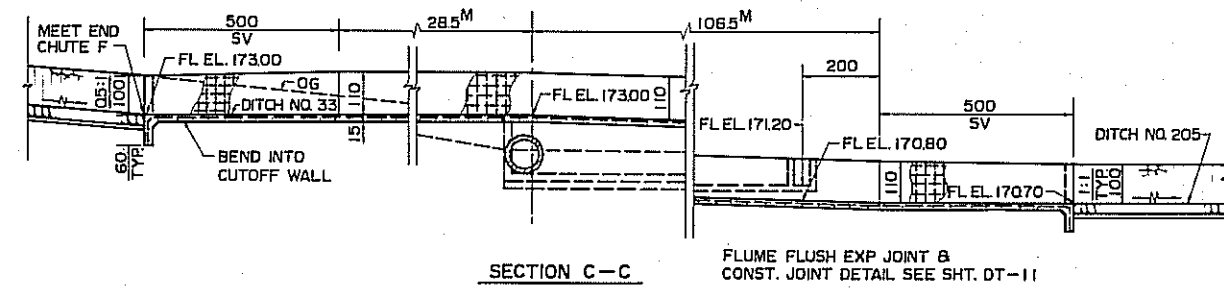
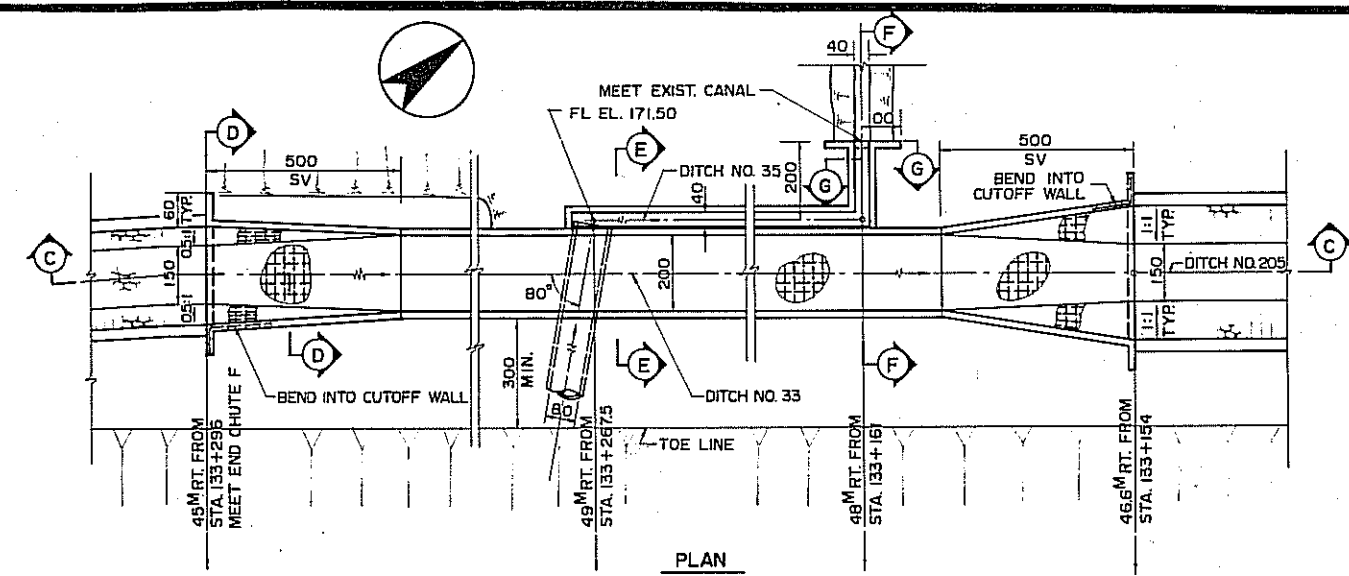
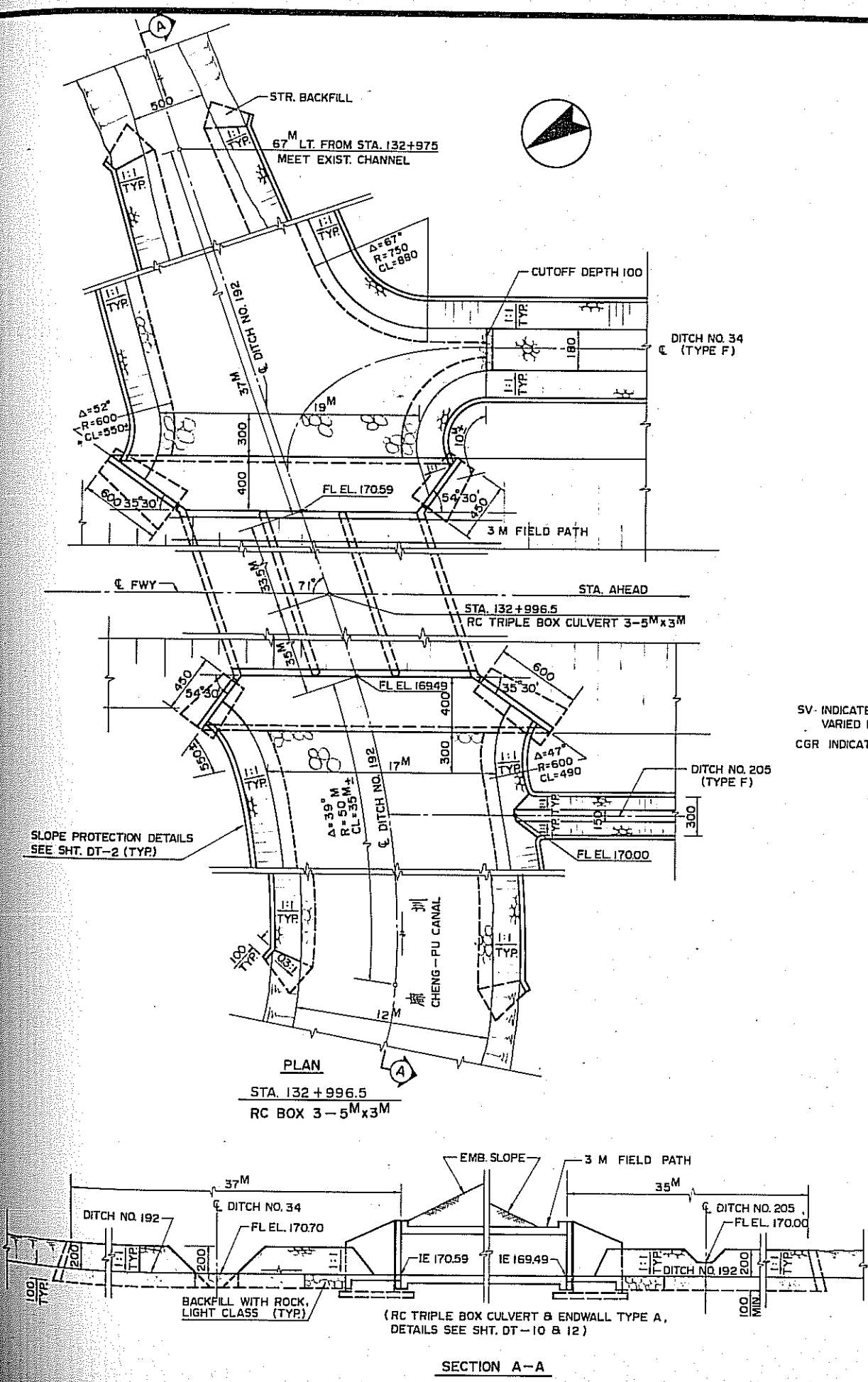

SV INDICATES THE SIDE SLOPE OF TRANSITION WALL
VARIED FROM UPSTREAM TO DOWNSTREAM.
CGR INDICATES CONC. GROUTED ROCK.

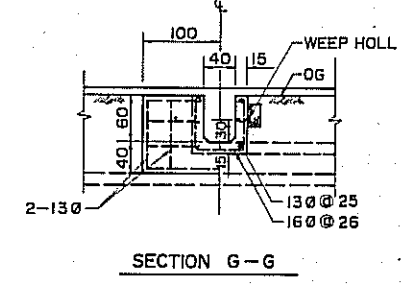
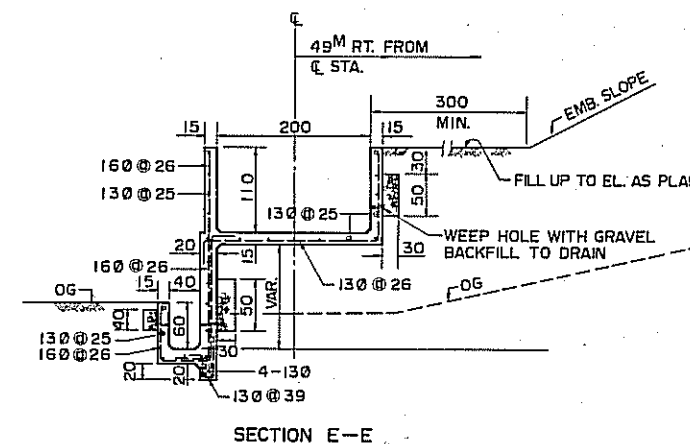
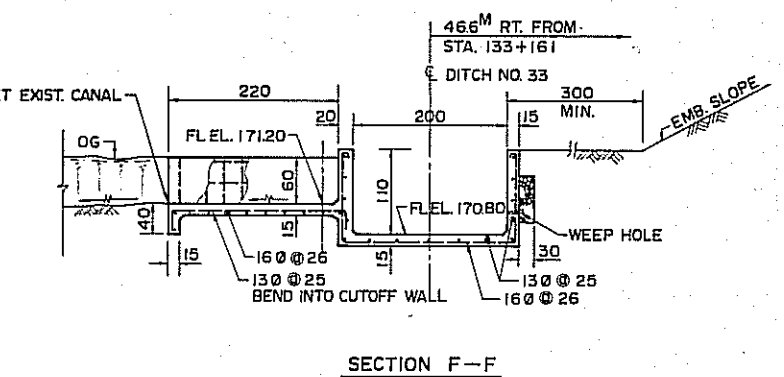
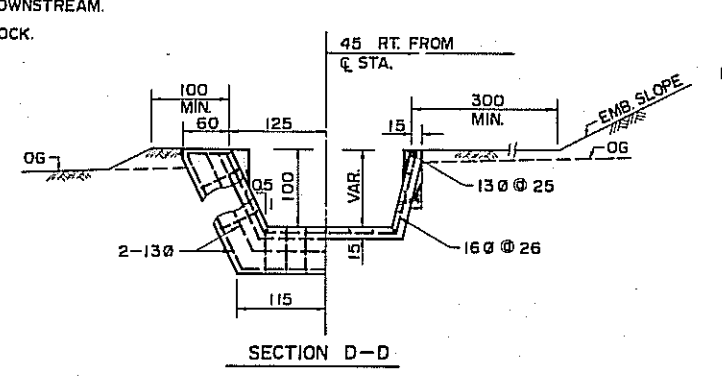

PROJECT 60

修正	REVISIONS	交通部台灣區高速公路工程局
項目	ITEM	TAIWAN AREA FREEWAY CONSTRUCTION BUREAU
日期	DATE	中華民國
		南北高速公路 NORTH-SOUTH FREEWAY
		苗栗台中段 MIAOLI-TAICHUNG SECTION
		箱涵進出口處理(III) RC BOX-END LAYOUT (III)
		中華顧問工程司 CHINA ENGINEERING CONSULTANTS, INC.
		日期 DATE AUG. '74 比例 SCALE NTS 圖號 SHEET D-17

灌渠改道 (STA. 133+267.5)
CANAL RELOCATION (STA. 133+267.5)

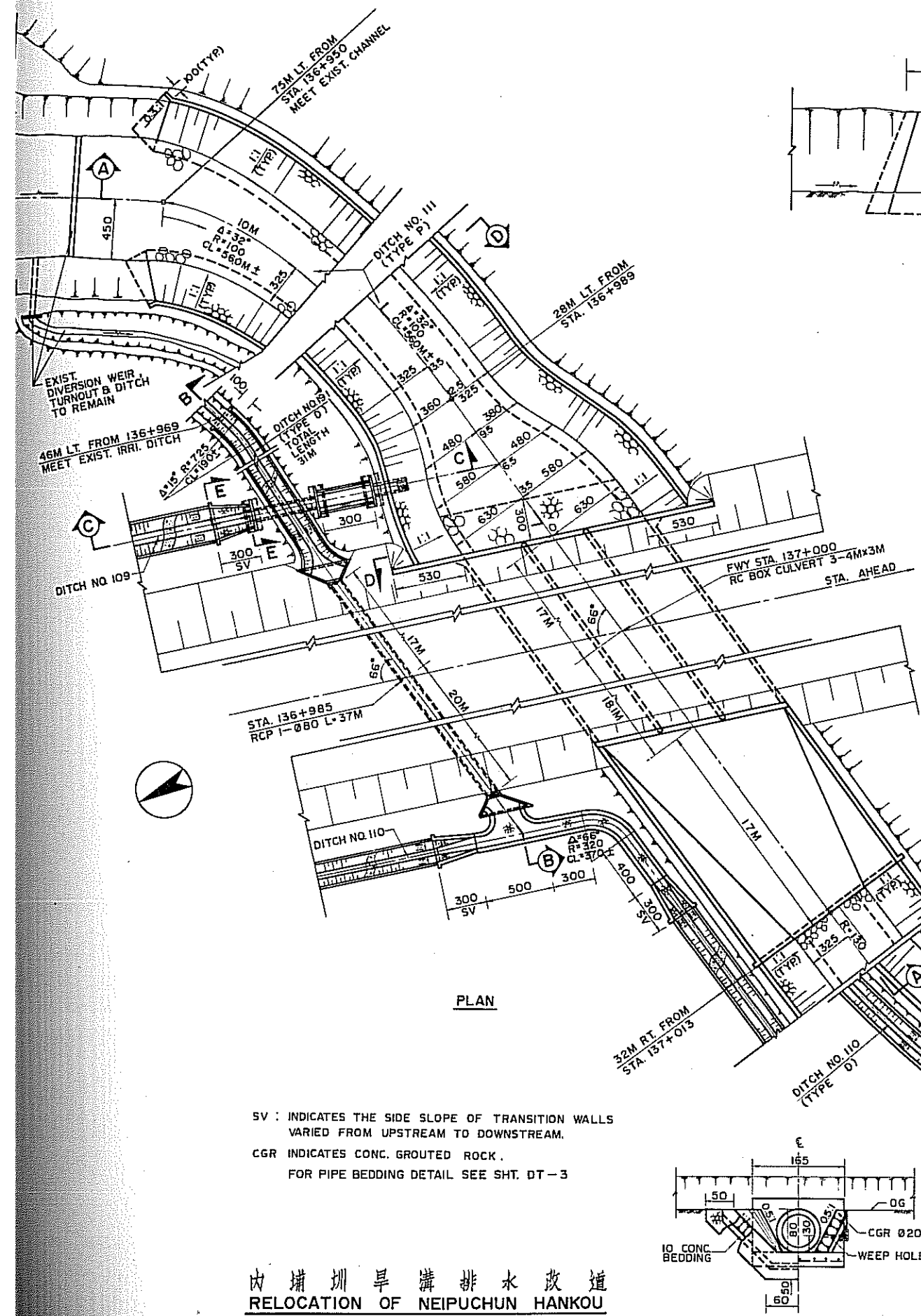

PLAN

SV : INDICATES THE SIDE SLOPE OF TRANSITION WALLS VARIED FROM UPSTREAM TO DOWNSTREAM.
 CGR INDICATES CONC. GROUTED ROCK.
 FOR PIPE BEDDING DETAIL SEE SHT. DT-3

內埔圳旱溝排水改道
 RELOCATION OF NEIPUCHUN HANKOU

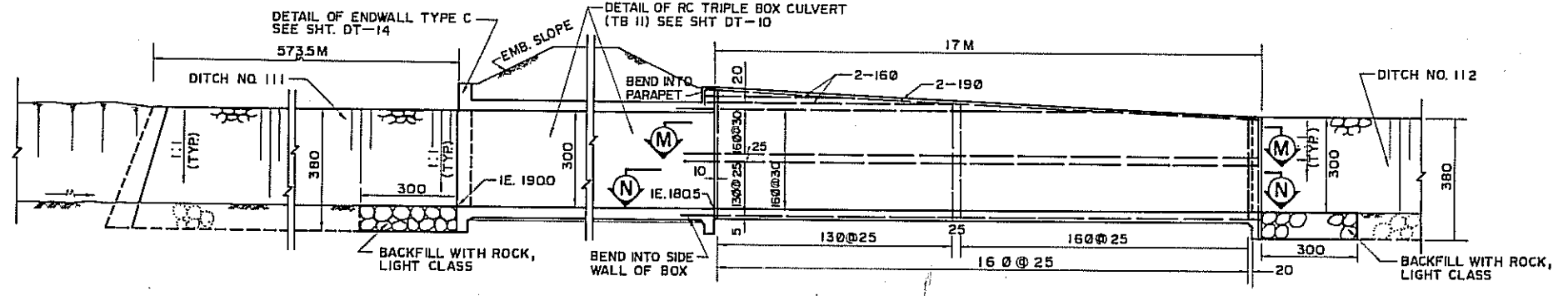

SECTION A-A

THE ARRANGEMENT OF REINFORCEMENT FOR DOWNSTREAM ENDWALL & WING WALLS ARE THE SAME AS TYPE B OF BOX CULVERT ENDWALL AND SEE SHT. DT-13 FOR REFERENCE.

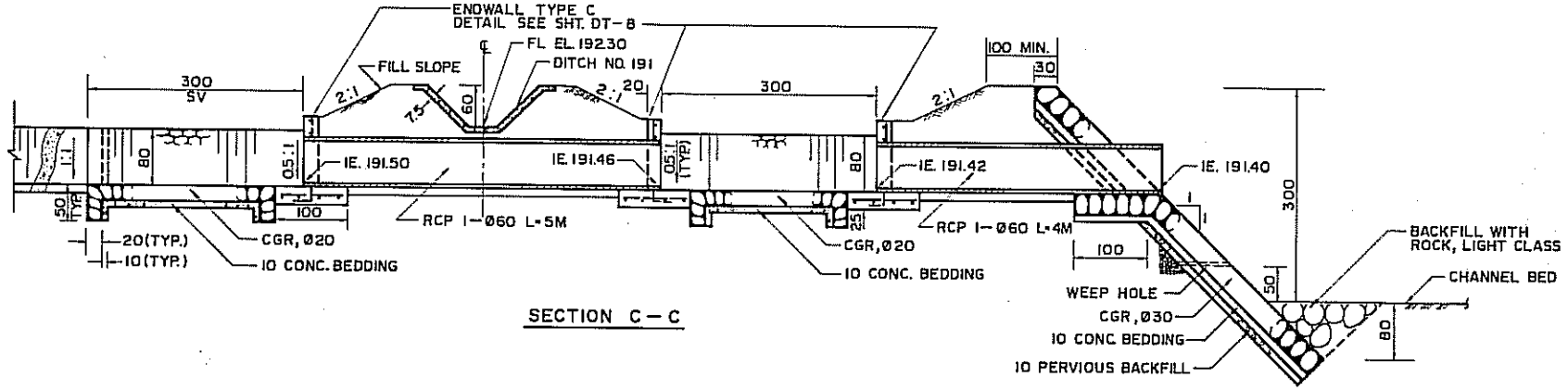

SECTION C-C

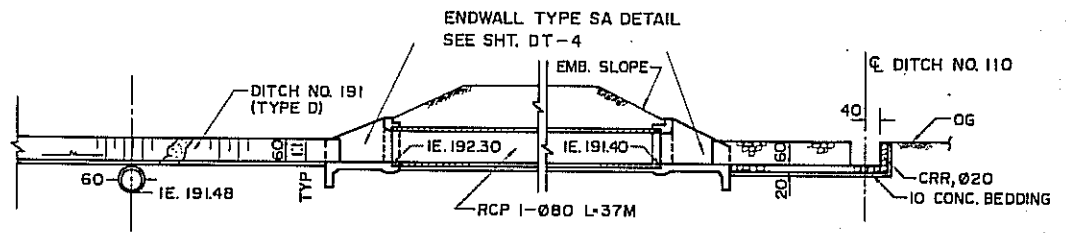

SECTION B-B

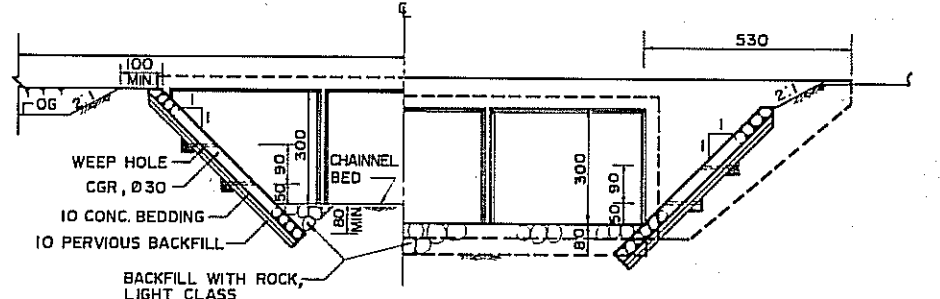

SECTION D-D

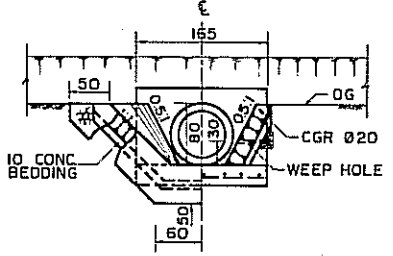

SECTION E-E

90M RT. FROM STA. 137+050 MEET EXIST. IRR. DITCH (FL EL. 191.20)

PROJECT 60

修正 REVISIONS		交通部台灣區高速公路工程局	
項目 ITEM	日期 DATE	TAIWAN AREA FREEWAY CONSTRUCTION BUREAU	中華民國
			南北高速公路 NORTH-SOUTH FREEWAY
			苗栗台中段 MIAOLI-TAICHUNG SECTION
			排水路改道(I) DRAINAGE CHANNEL RELOCATION (I)
			中華顧問工程司 CHINA ENGINEERING CONSULTANTS, INC.
			日期 DATE AUG '74 比例 SCALE NT 5 圖號 SHEET D-18

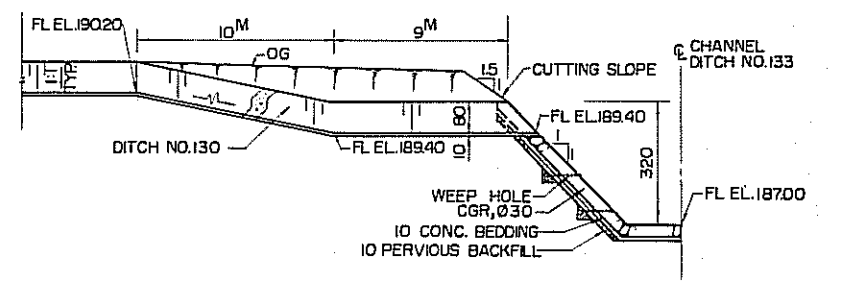
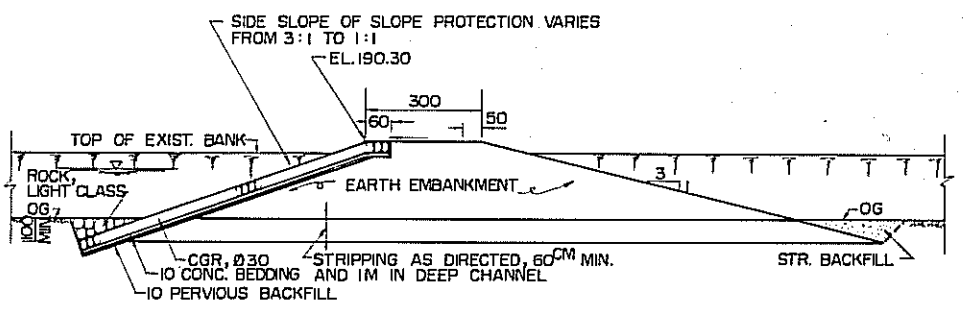
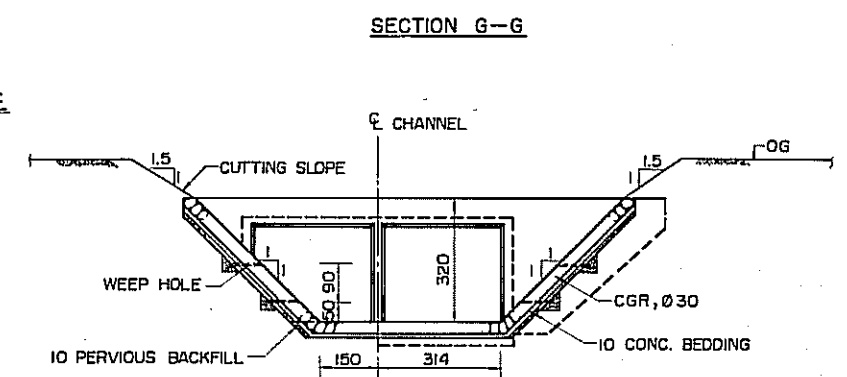
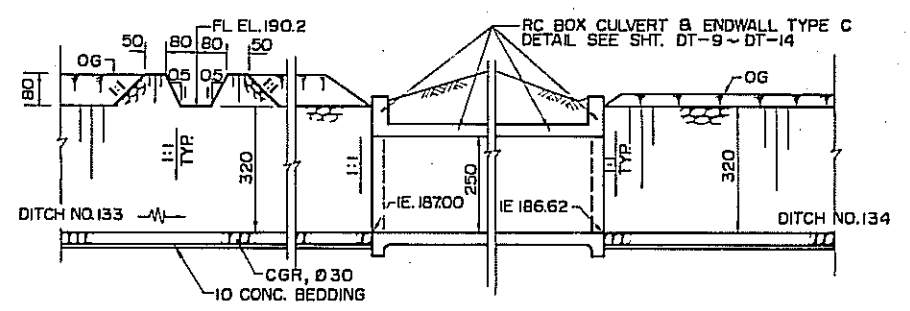
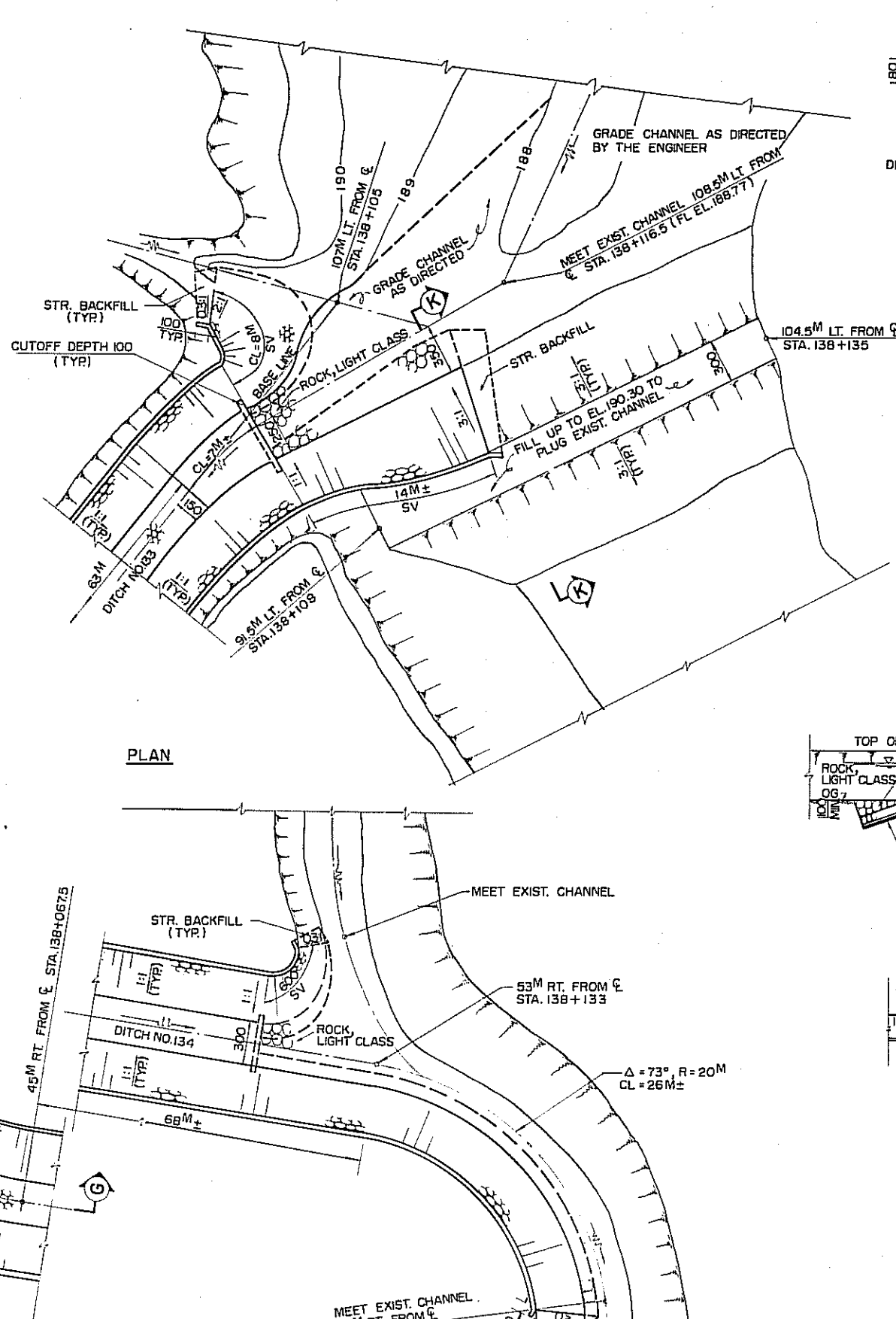
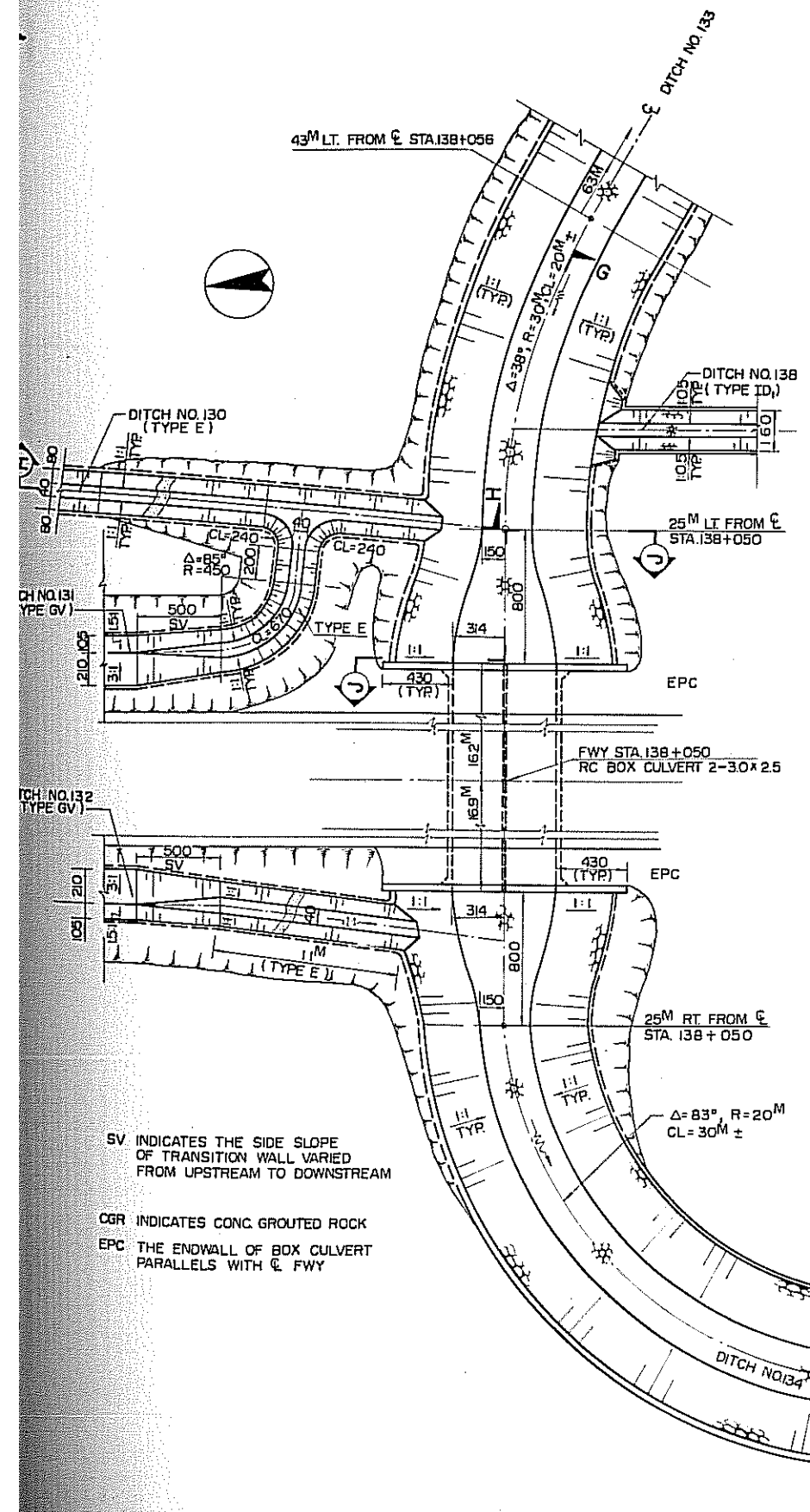

SV INDICATES THE SIDE SLOPE OF TRANSITION WALL VARIED FROM UPSTREAM TO DOWNSTREAM

CGR INDICATES CONC. GROUTED ROCK

EPC THE ENDWALL OF BOX CULVERT PARALLELS WITH C FWY

138+050 排水路改道
DRAINAGE CHANNEL RELOCATION @ 138+050

修正	REVISIONS	項目	ITEM	日期	DATE

交通部台灣區高速公路工程局
TAIWAN AREA FREEWAY CONSTRUCTION BUREAU
中華民國
REPUBLIC OF CHINA
南北高速公路 NORTH-SOUTH FREEWAY
苗栗台中段 MIAOLI-TAICHUNG SECTION
排水路改道(II) DRAINAGE CHANNEL RELOCATION (II)
中華顧問工程司 CHINA ENGINEERING CONSULTANTS, INC.
日期 DATE AUG '74 比例 SCALE NTS 圖號 SHEET D-19

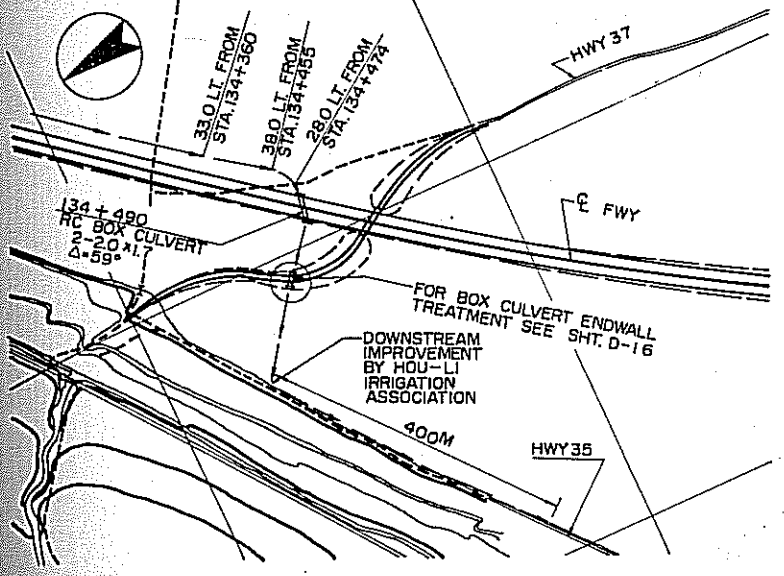

LOCATION MAP
SCALE 1:5000

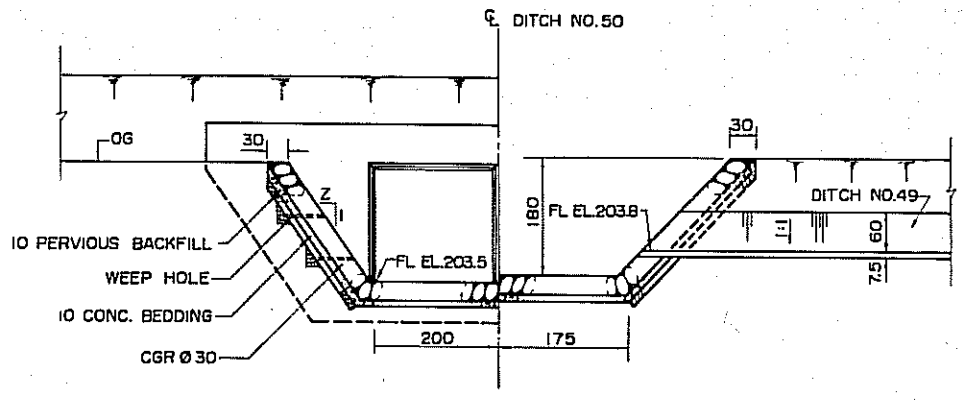

SECTION A-A

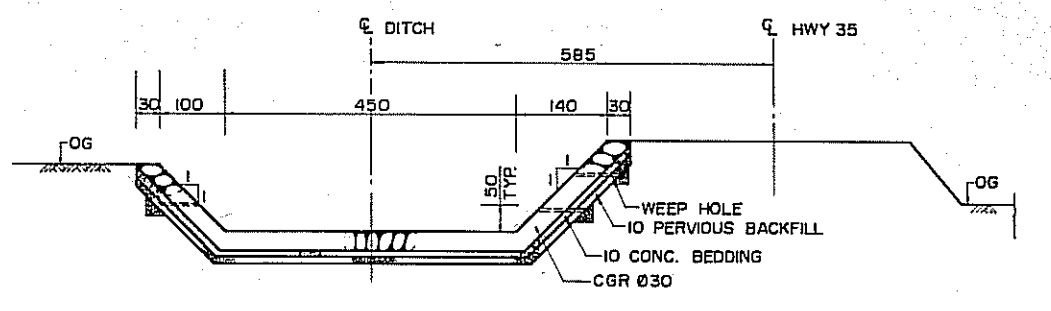

SECTION D-D

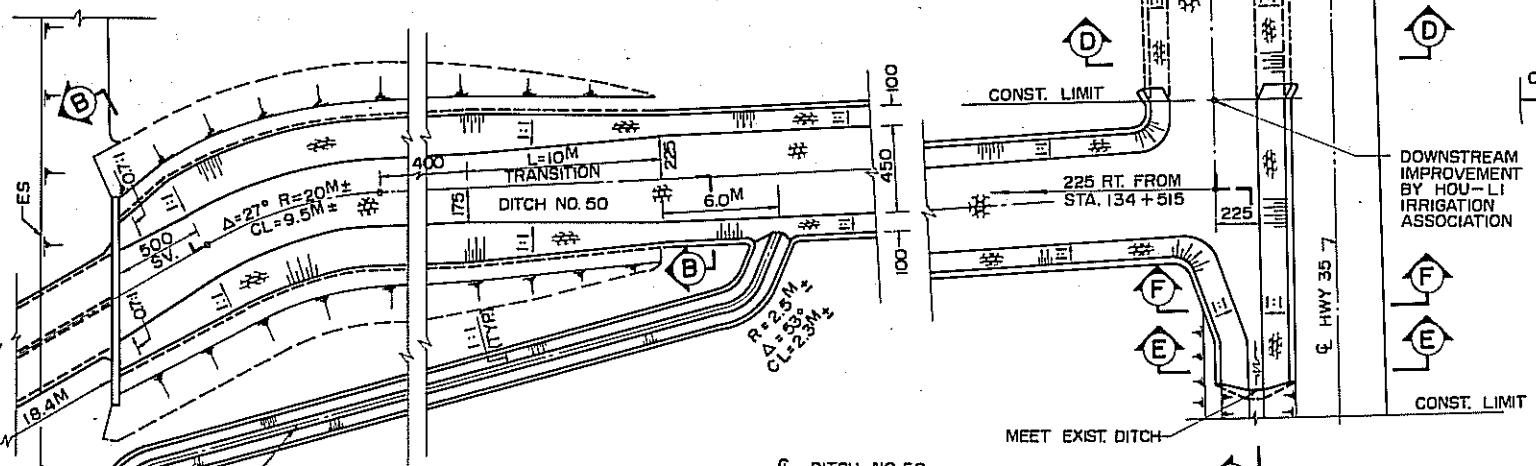

PLAN

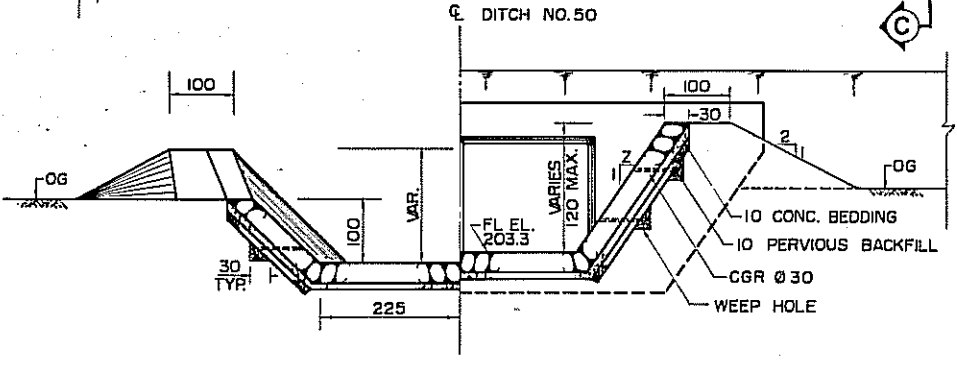

SECTION B-B

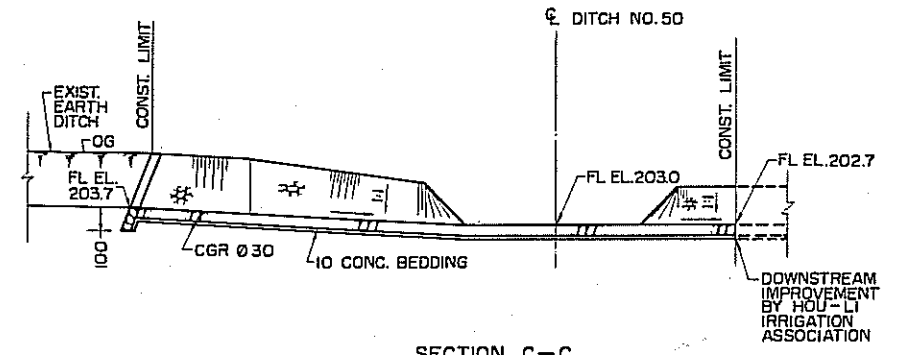

SECTION C-C

CGR : CONCRETE GROUTED ROCK
SV INDICATES THE SIDE SLOPE OF TRANSITION WALLS VARIED FROM UPSTREAM TO DOWNSTREAM

PROJECT 60

修正	REVISIONS	項目	ITEM	日期	DATE

交通部台灣區高速公路工程局
TAIWAN AREA FREEWAY CONSTRUCTION BUREAU
中華民國
中華人民共和國
南北高速公路 NORTH-SOUTH FREEWAY
苗栗台中段 MIAOLI-TAICHUNG SECTION
排水路改道(III) DRAINAGE CHANNEL RELOCATION (III)
中華顧問工程司 CHINA ENGINEERING CONSULTANTS, INC.
日期 DATE AUG. '74 比例 SCALE NTS 圖號 SHEET D-20

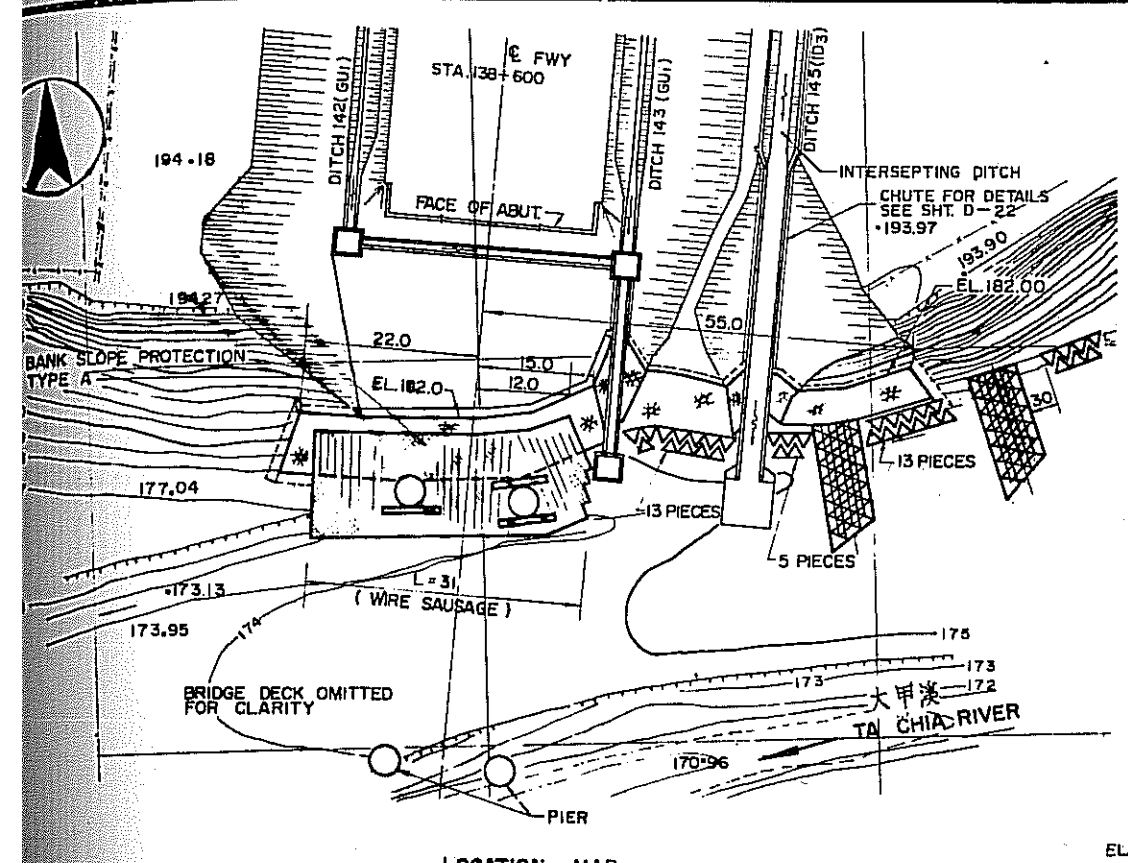

LOCATION MAP

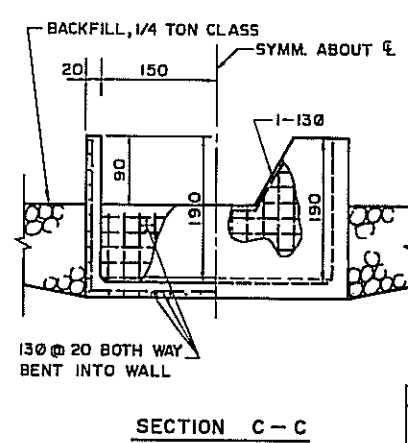

SECTION C - C

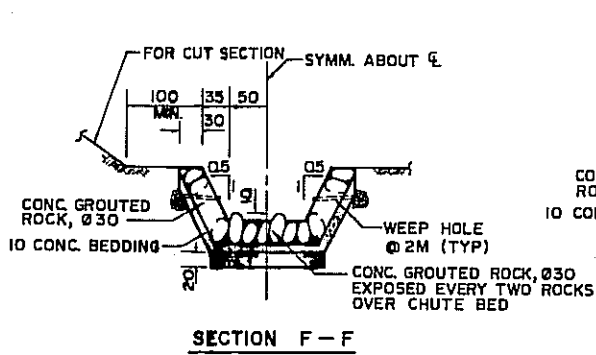

SECTION F - F

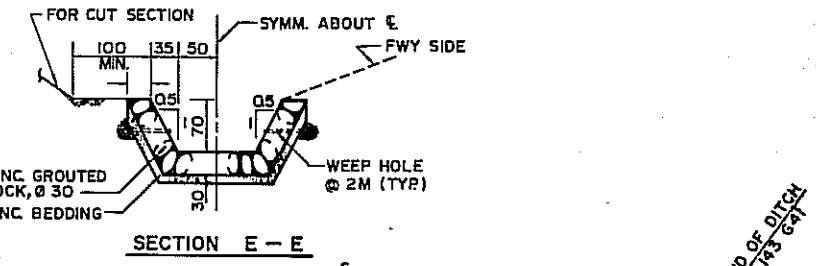

SECTION E - E

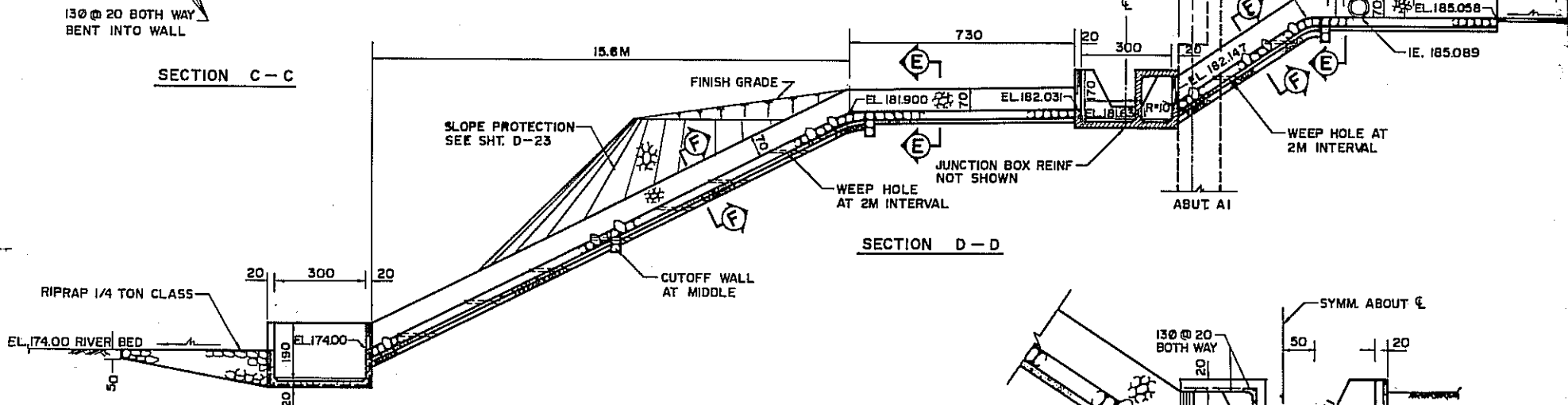

SECTION D - D

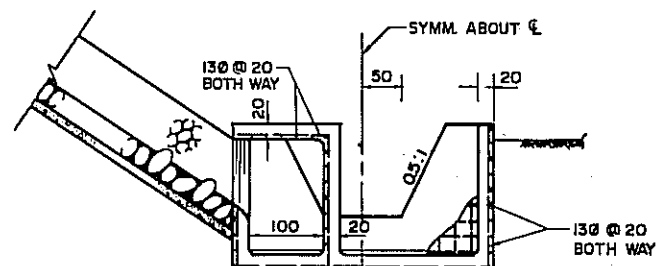

DETAIL OF JUNCTION BOX

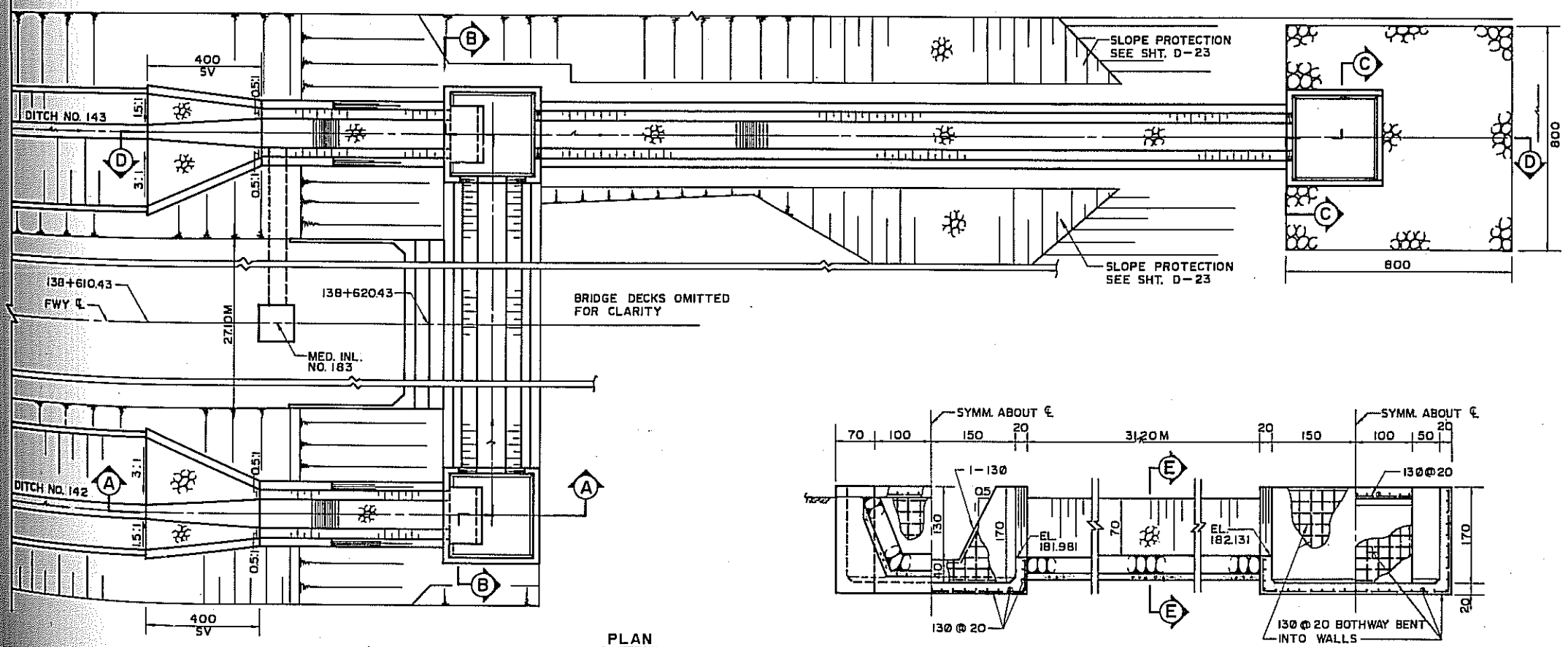

PLAN

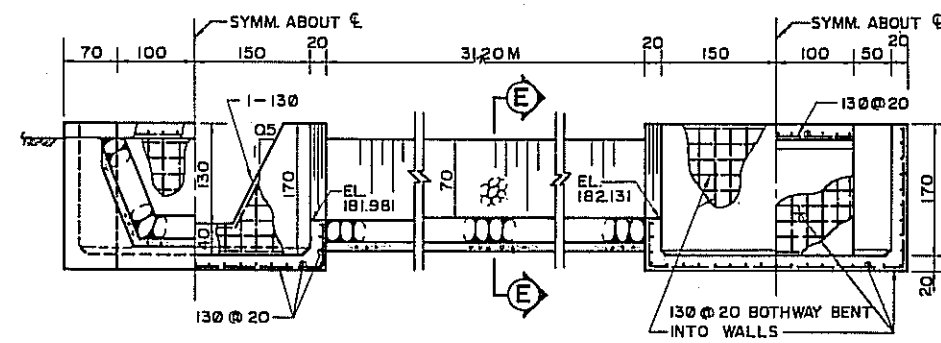

SECTION B - B

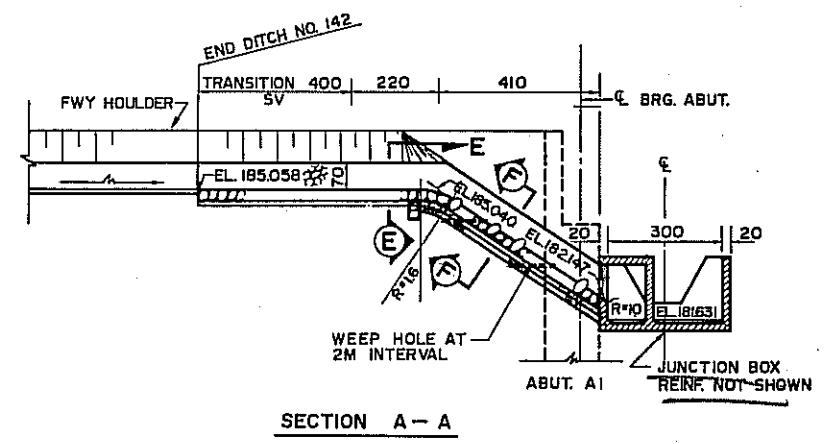

SECTION A - A

SV INDICATES THE SIDE SLOPE OF TRANSITION WALLS VARIED FROM UPSTREAM TO DOWNSTREAM

修正 REVISIONS	項目 ITEM	日期 DATE	交通部台灣區高速公路工程局 TAIWAN AREA FREEWAY CONSTRUCTION BUREAU 中華民國 REPUBLIC OF CHINA
			南北高速公路 MIAOLI-TAICHUNG SECTION
			大甲溪北岸排水(I) DRAINAGE ON TACHIA RIVER NORTH BANK (I)
			中華顧問工程司 CHINA ENGINEERING CONSULTANTS, INC.
			日期 DATE AUG. '74 比例 SCALE NT5 圖號 SHEET D-21

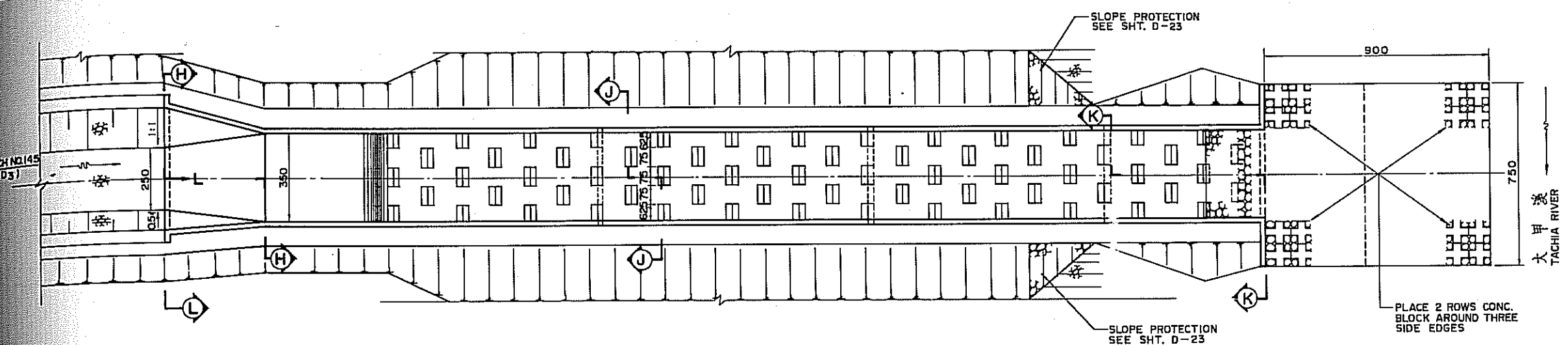

PLAN

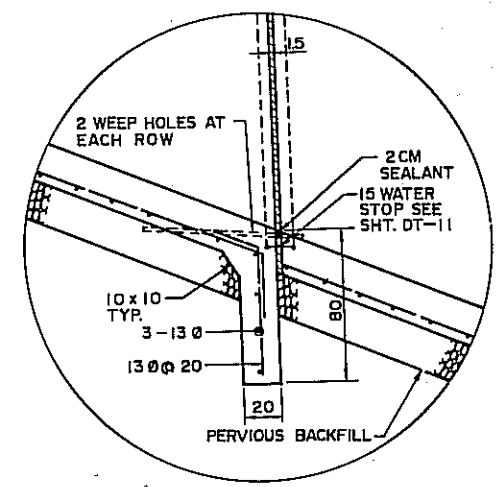

DETAIL H

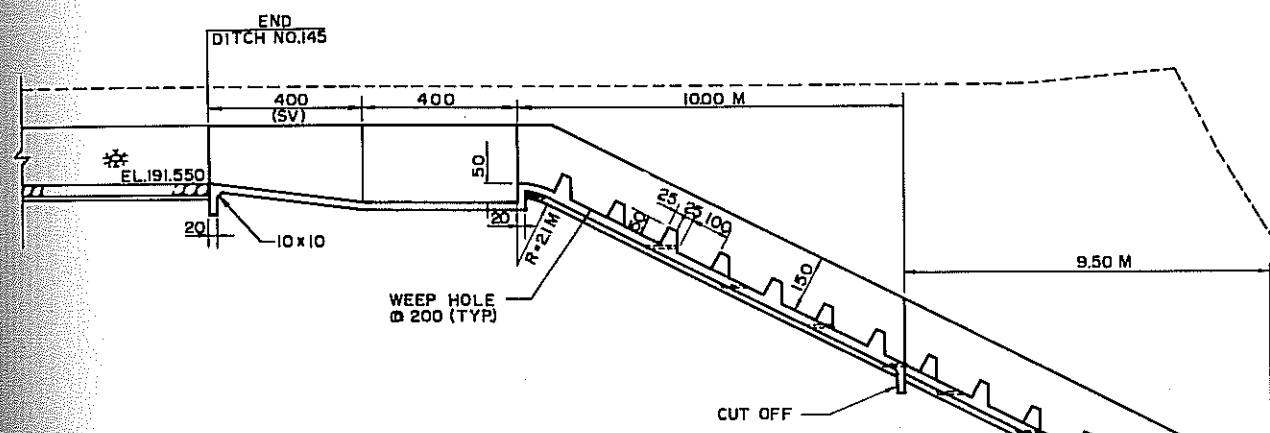

LONGITUDINAL SECTION

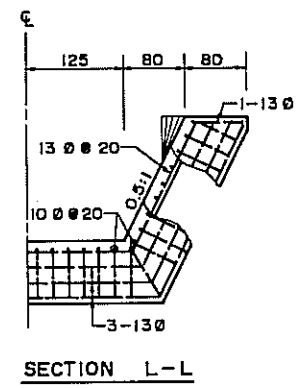

SECTION L-L

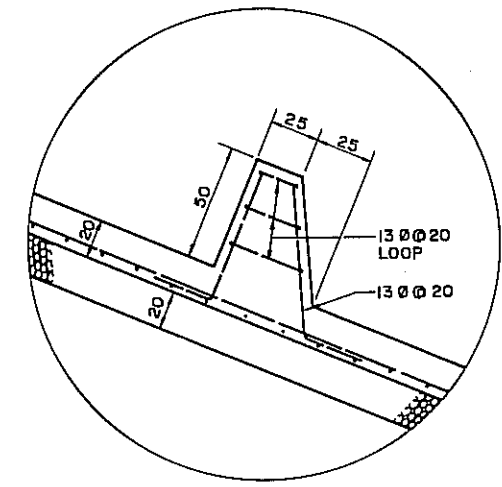

DETAIL F

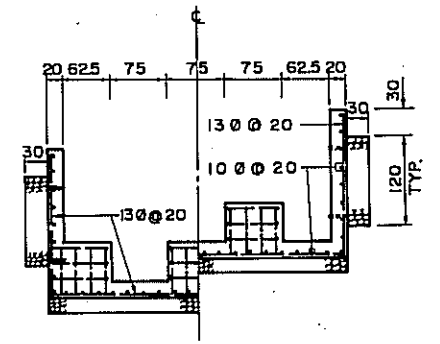

SECTION J-J

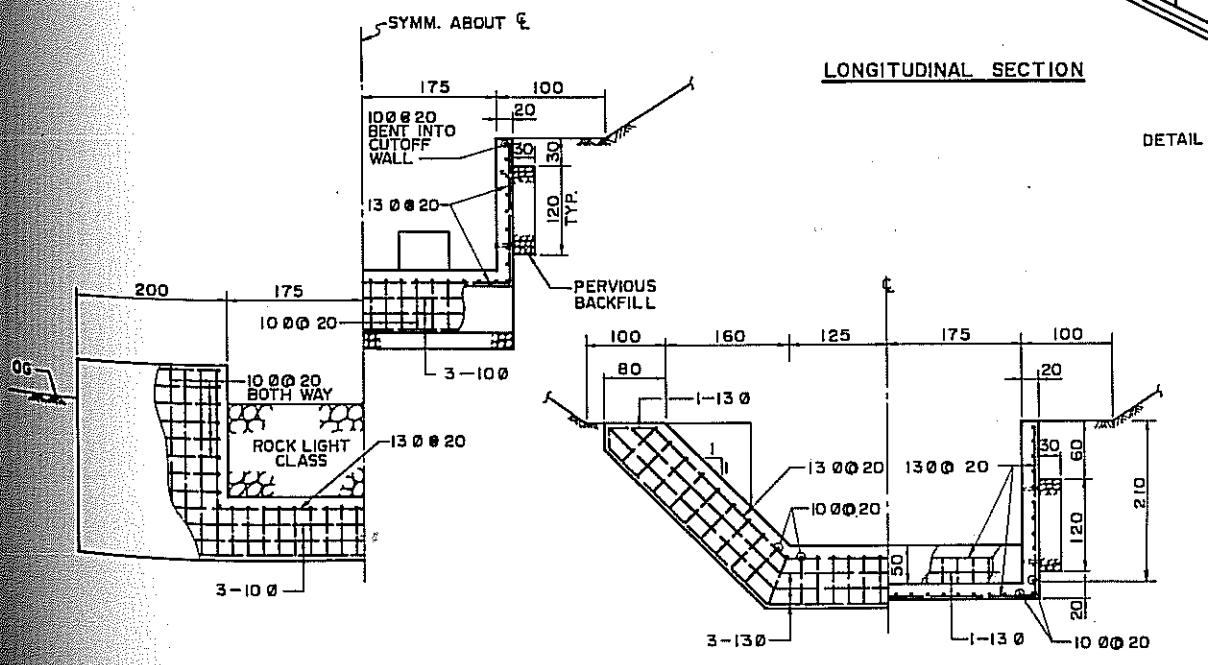

SECTION K-K

SECTION H-H

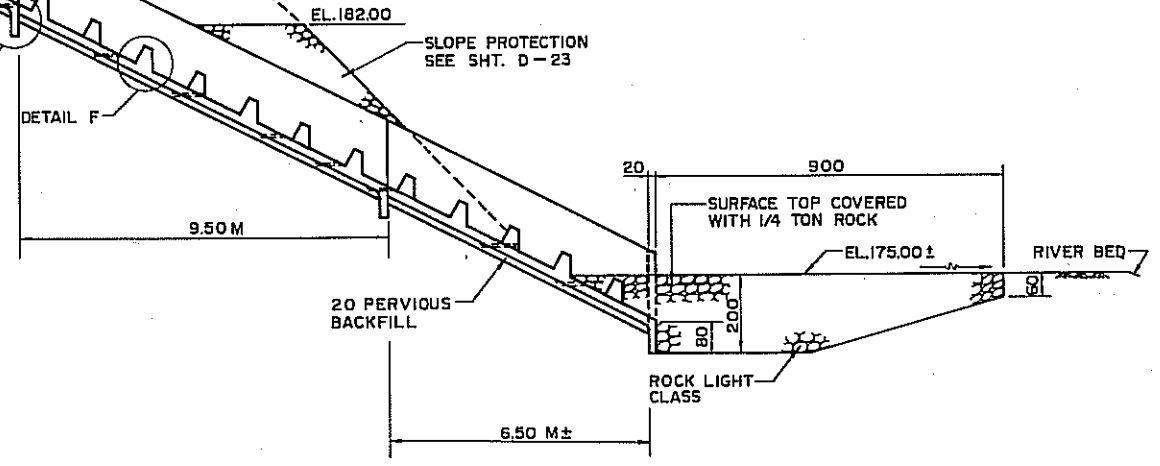

陡槽 CHUTE

PROJECT 60

修正	REVISIONS	項目	ITEM	日期	DATE

交通部台灣區高速公路工程局
TAIWAN AREA FREEWAY CONSTRUCTION BUREAU
中華民國
REPUBLIC OF CHINA
南北高速公路 NORTH-SOUTH FREEWAY
苗栗台中段 MIAOLI-TAICHUNG SECTION
大甲溪北岸排水(II) DRAINAGE ON TACHIA
RIVER NORTH BANK (II)
中華顧問工程司 CHINA ENGINEERING CONSULTANTS, INC.
日期 DATE AUG '74 比例 SCALE NTS 圖號 SHEET D-22

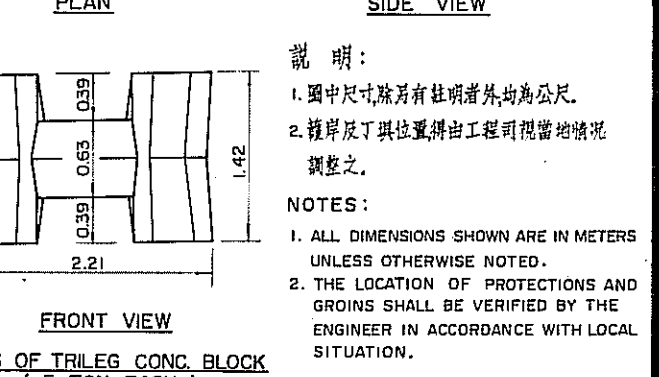
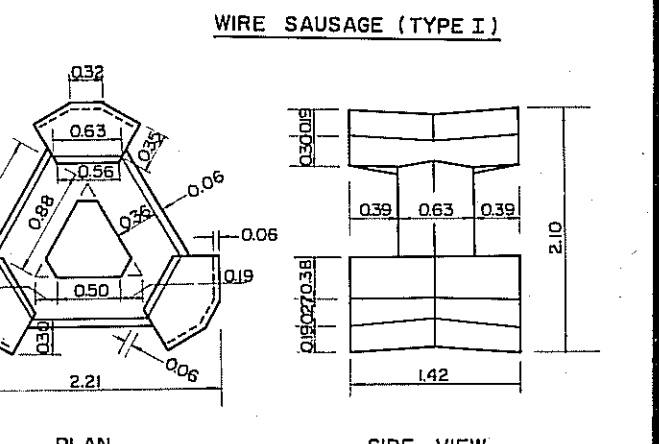
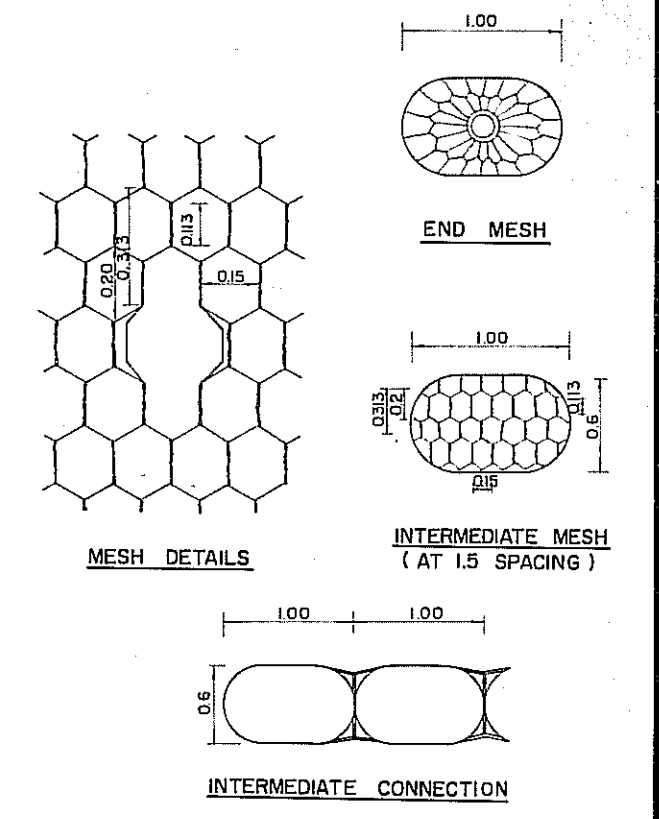
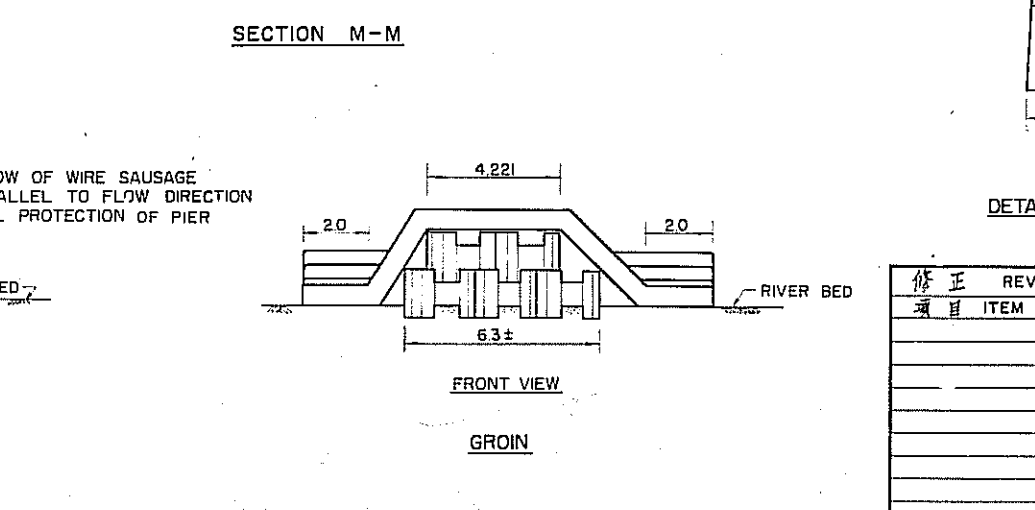
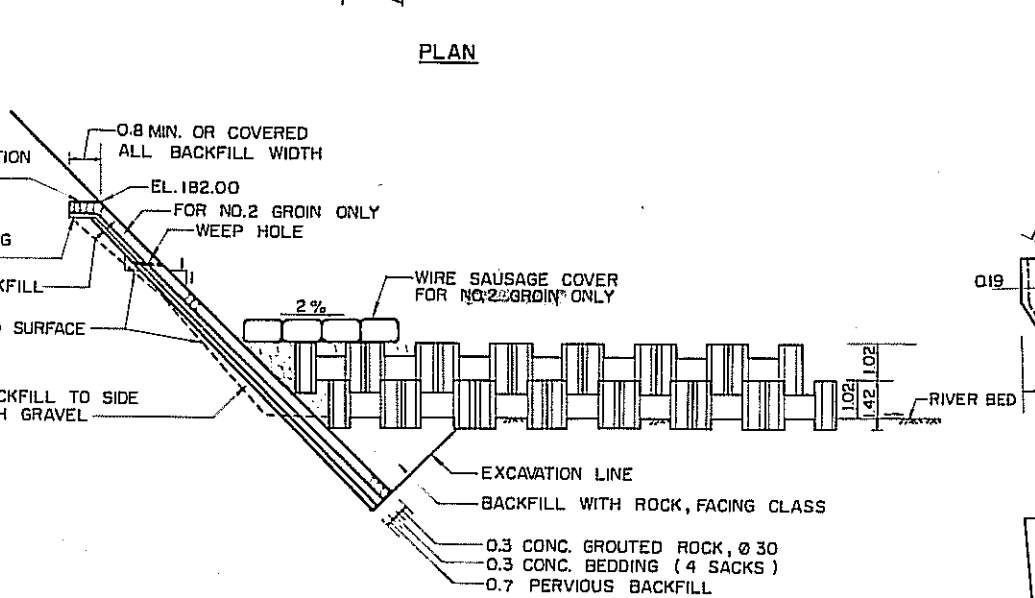
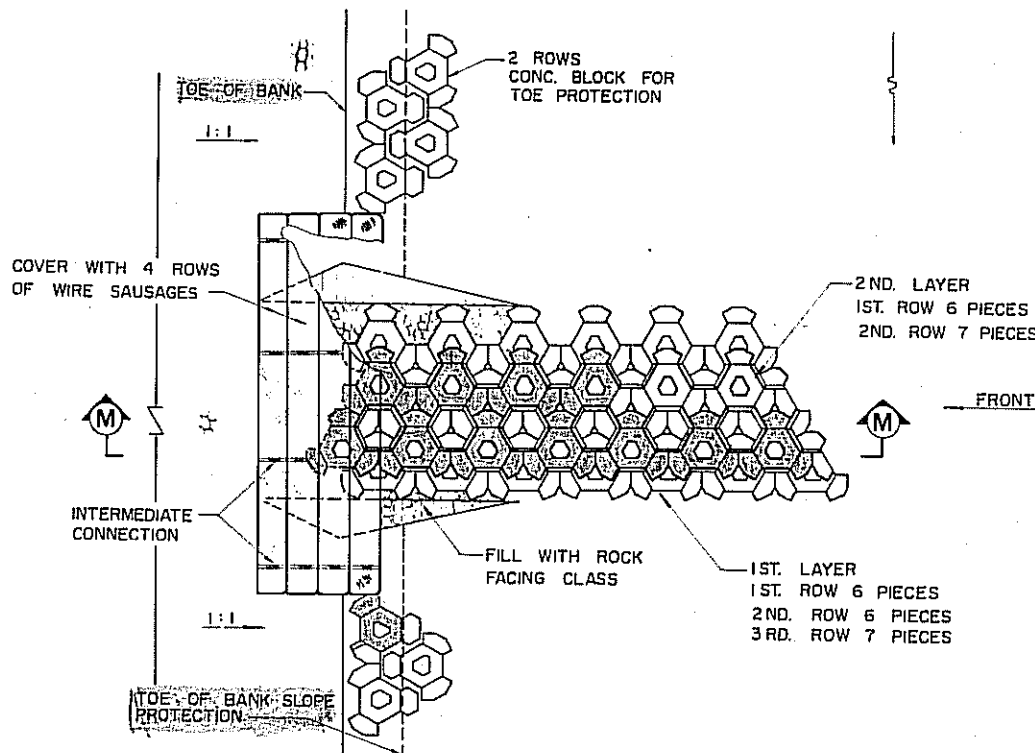
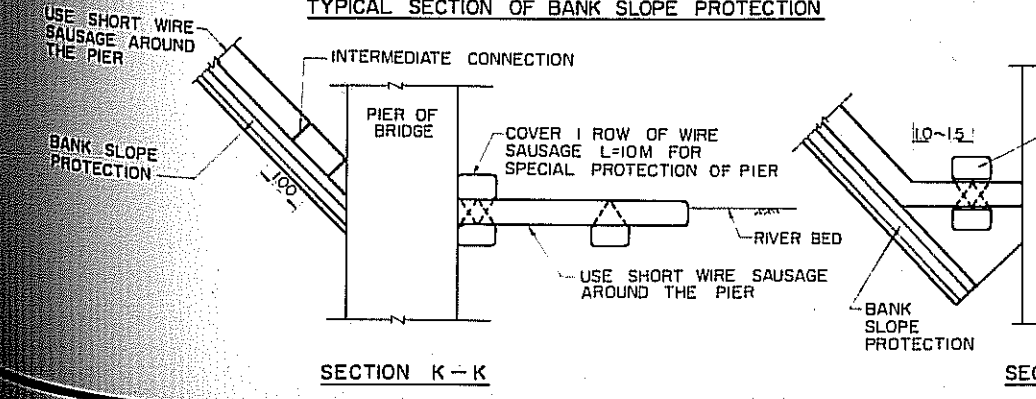
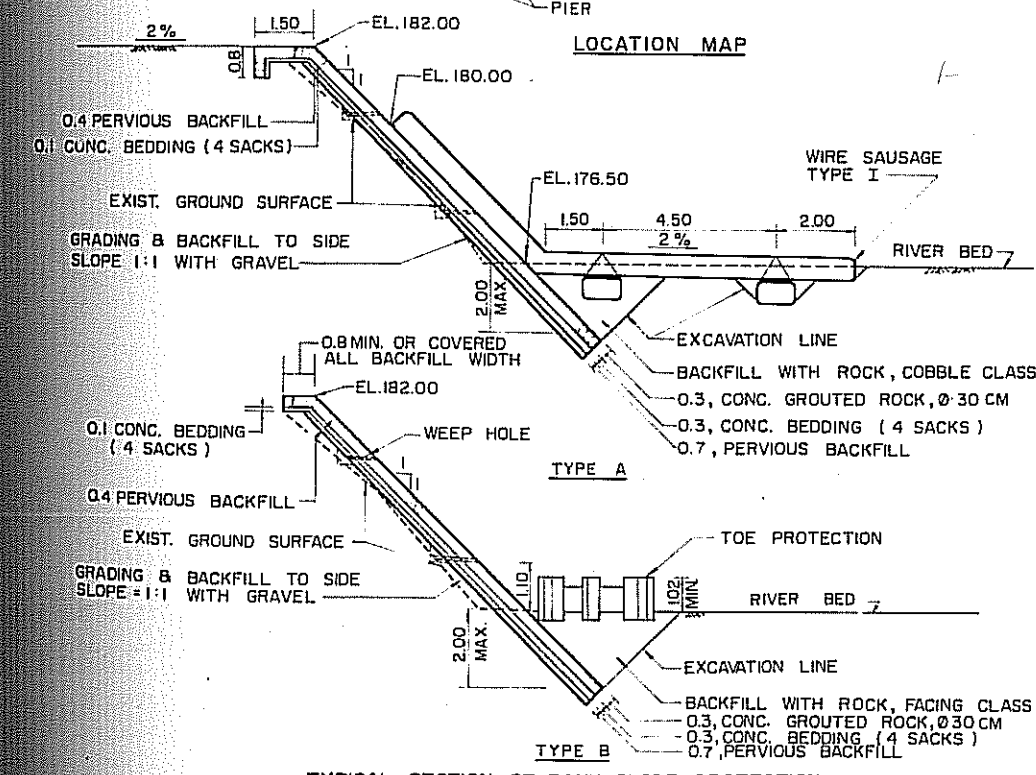
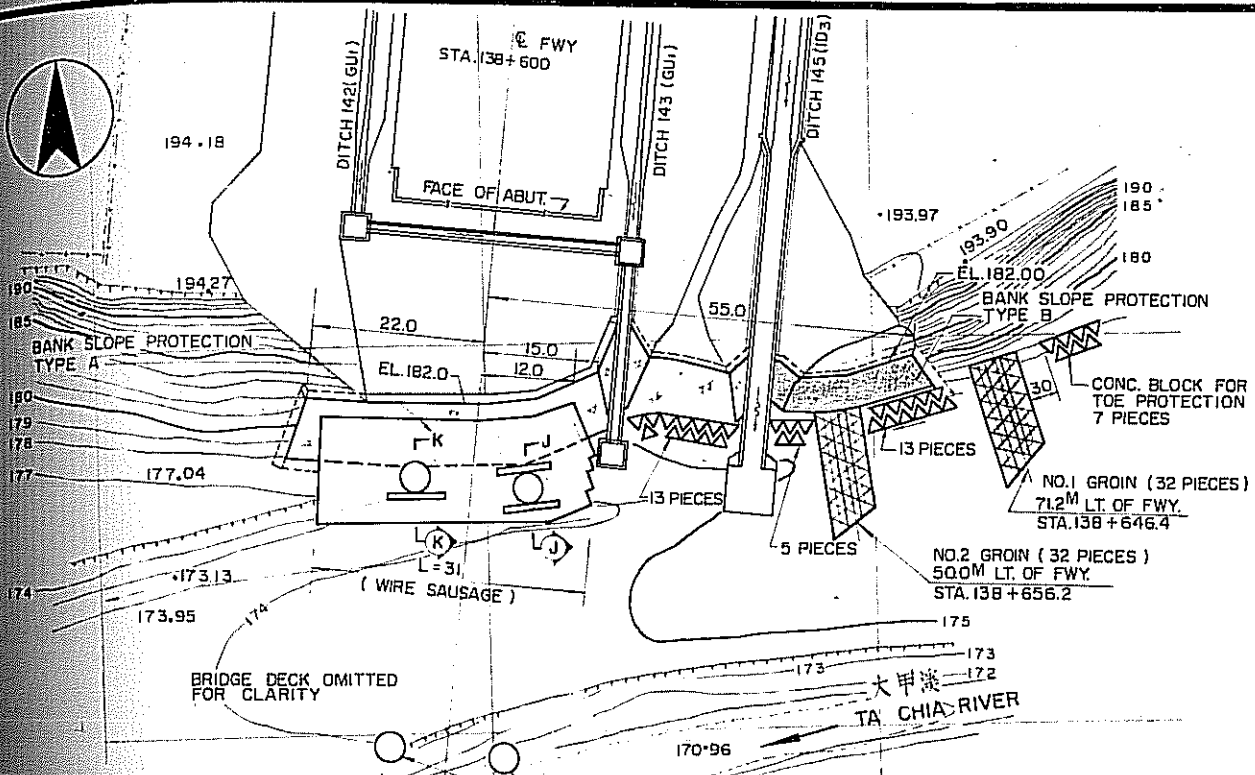

修正 REVISIONS
項目 ITEM 日期 DATE

交通部台灣區高速公路工程局
TAIWAN AREA FREEWAY CONSTRUCTION BUREAU
中華民國
台北高速公路 NORTH-SOUTH FREEWAY
苗栗台中段 MIAOLI-TAICHUNG SECTION
大甲溪北岸護岸 TA-CHIA RIVER NORTH BANK PROTECTION
中華顧問工程司 CHINA ENGINEERING CONSULTANTS, INC.
日期 DATE AUG '74 比例 SCALE NTS 圖號 SHEET D-23

說明:
1. 圖中尺寸除另有註明者外均為公尺。
2. 護岸及丁其位置得由工程師視當地情況調整之。

NOTES:
1. ALL DIMENSIONS SHOWN ARE IN METERS UNLESS OTHERWISE NOTED.
2. THE LOCATION OF PROTECTIONS AND GROINS SHALL BE VERIFIED BY THE ENGINEER IN ACCORDANCE WITH LOCAL SITUATION.

PROJECT 60

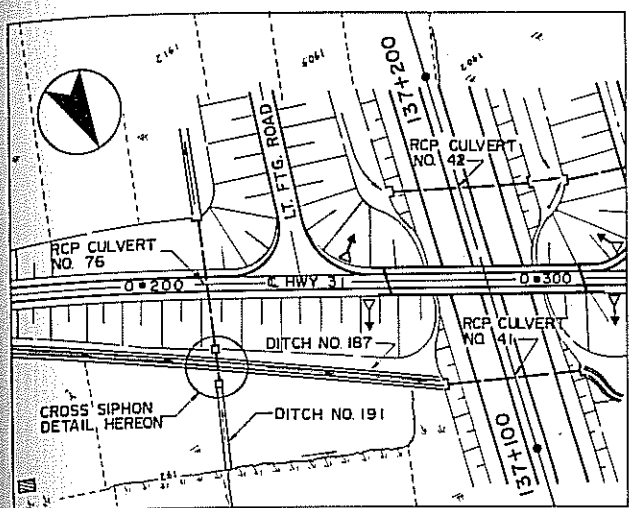

LOCATION MAP
SCALE 1:1000

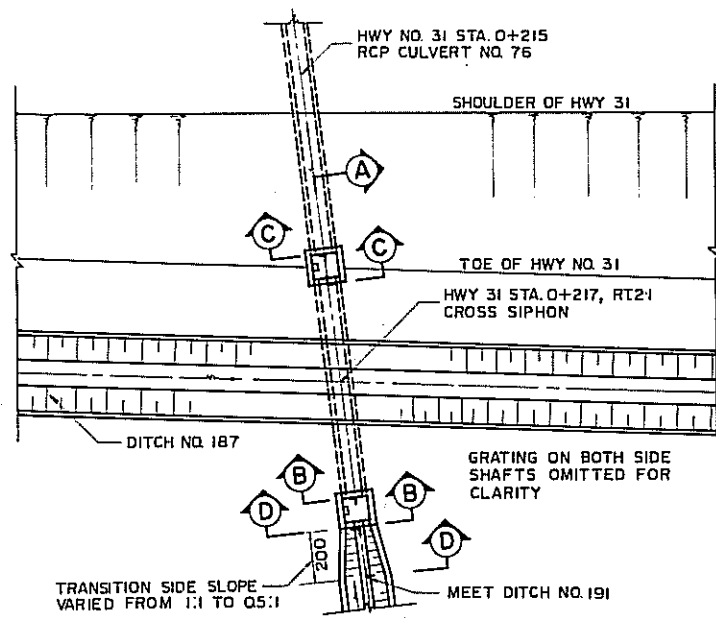

PLAN

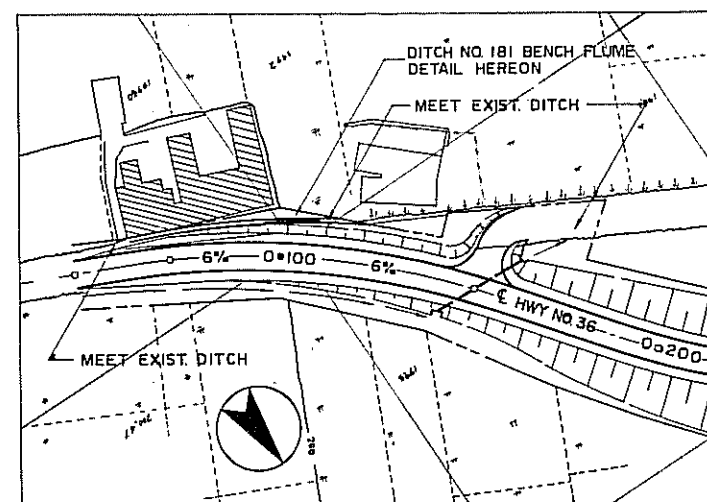

LOCATION MAP
SCALE 1:1000

DITCH COVER CONSTRUCTION TABLE

LOCATION	L CM	H CM	T CM	① BAR		② BAR	
				Ø	SPACING (CM)	Ø	SPACING (CM)
132+823 LT. 29	300	100	25	19	14	13	20
133+017 LT. 48	500	200	30	22	13	16	25
134+355 LT. 30	550	100	30	22	13	16	25
HWY 132 0+276 RT. 28	550	150	30	22	13	16	25

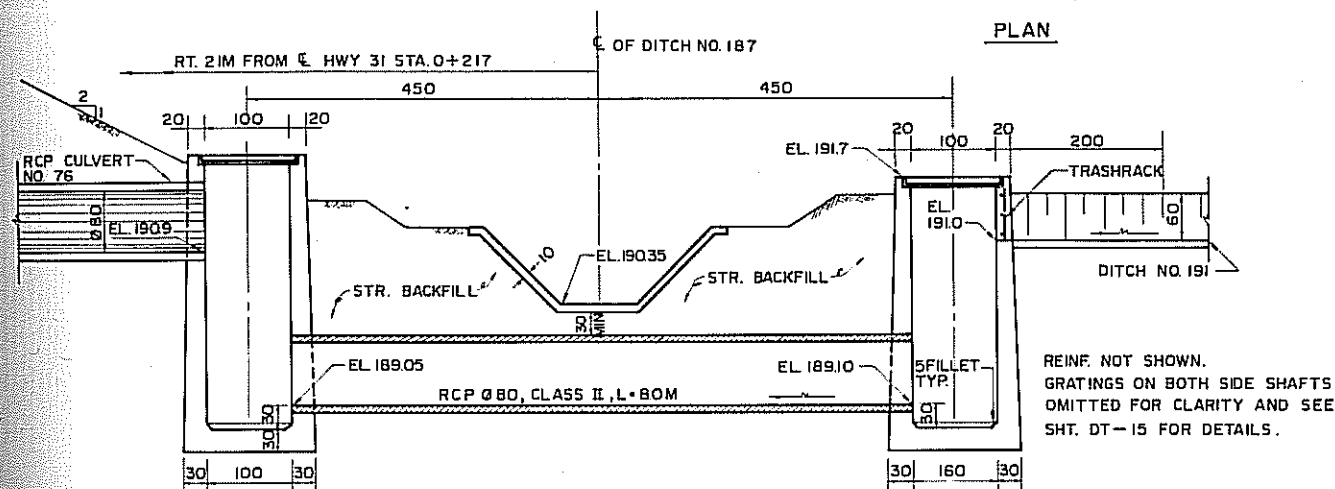

SECTION A-A

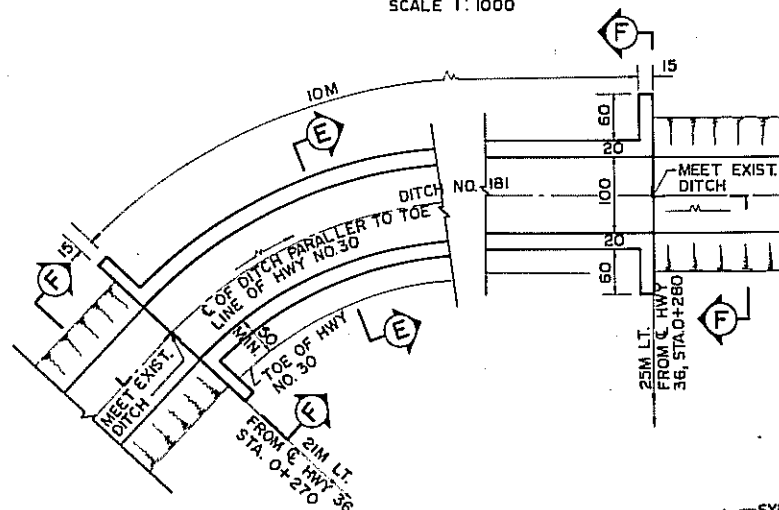

SECTION F-F

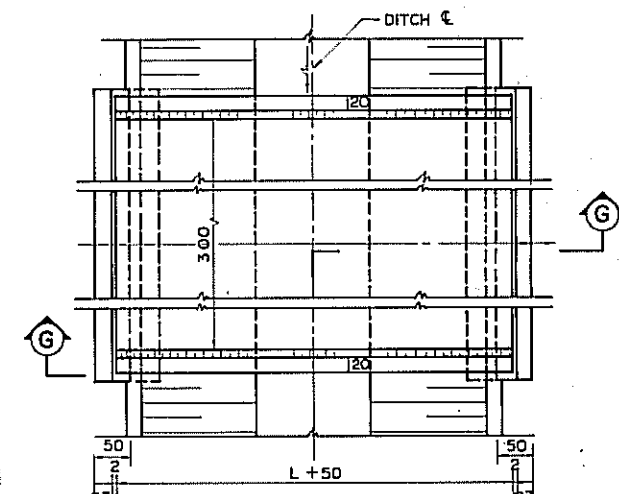

SECTION G-G

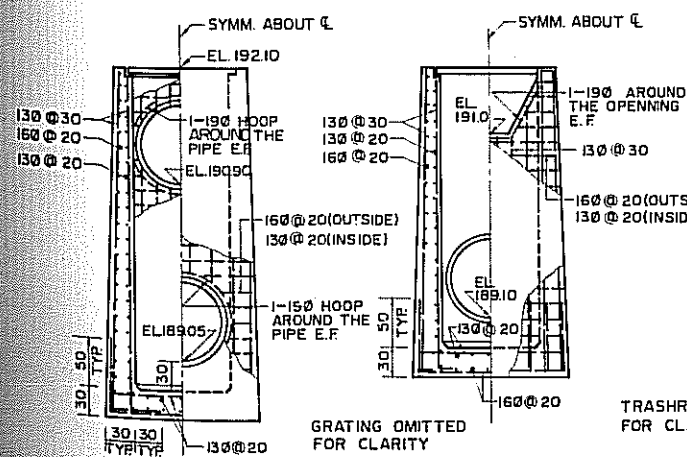

SECTION C-C

SECTION B-B

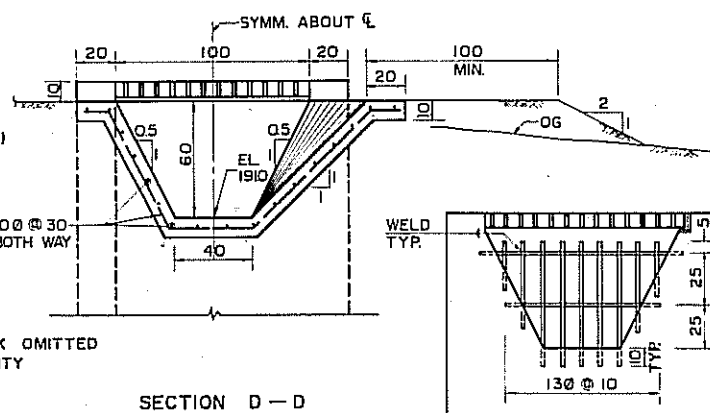

SECTION D-D

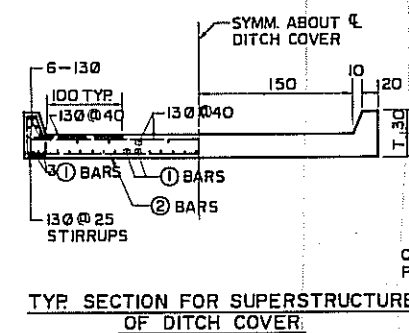

TYP. SECTION FOR SUPERSTRUCTURE
OF DITCH COVER

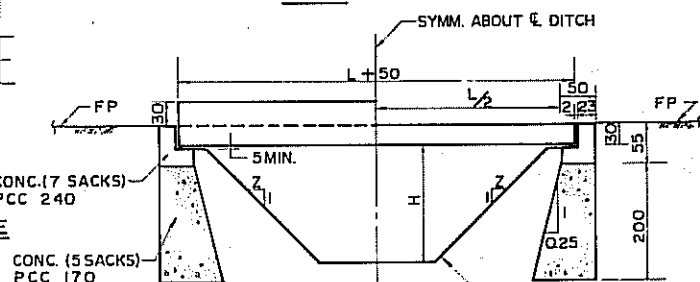

SECTION G-G

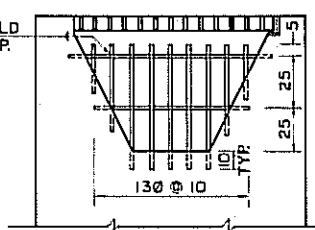

DETAIL OF TRASHRACK

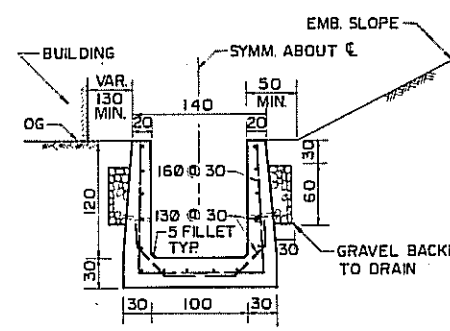

SECTION E-E

STEEL RUNGS ON BOTH SIDE SHAFTS
OMITTED FOR CLARITY SEE SHT. DT-15
FOR DETAILS.

橫交虹吸工
CROSS SIPHON (HWY 31 STA. 0+217, RT 21M)

座槽
BENCH FLUME

蓋版橋
DITCH COVER

PROJECT 60

修正 REVISIONS	項目 ITEM	日期 DATE	交通部台灣區高速公路工程局 TAIWAN AREA FREEWAY CONSTRUCTION BUREAU 中華民國 南北高速公路 苗栗台中段	NORTH-SOUTH FREEWAY MIAOLI-TAICHUNG SECTION
			雜項排水設施 MISCELLANEOUS DRAINAGE DETAILS	
			中華顧問工程司 CHINA ENGINEERING CONSULTANTS, INC.	
			日期 DATE AUG. '74 比例 SCALE NTS	圖號 SHEET D-24

一 說 明

1. 排水設計圖上所有尺寸，除另有註明者外，均為公分。
2. 所註距離均係水平丈量；所有水平尺度係以直角量計。
3. 所有管面而與明溝之位置、高程、交角以及溝段，工程局應依實地情況核定。
4. 承包應於施工前對設計圖中尺度、高程與位置，如發現有不符之處，應即報請工程師指示。
5. 對於現有溝渠或排水路之改造，應事先將現有溝渠，施工時不得妨礙排水之宜或破壞原有之引水。
6. 大開挖區在路基整理前，工程局視地下水流出情況，應止原設計之地下排水管（有孔型膠管）所附之長度，如無地下水現象時，則原設計圖之地下排水設施可以免設。
7. 圖中所註應設排水設施之連埋或改善須由其他單位實施者，承包應先提請工程局轉洽有關機關配合施工。
8. 圖中所註，同填石料“或。石料”，與拋石為同一計價項目。
9. 所有溝渠或溝渠兩側之洩水孔位置，如圖上未註明時，一律照工程局指示辦理。
10. 山溝河槽在給物開挖填後，須照工程局規定恢復原狀並略予整地。但為保持適當溝渠坡度以及安全上需要時，得依工程局之指示，整理溝道，並依渠道開挖規定施工。
11. 堤防（堤心）填土，除另有註明者外，悉比照土堤填築施工。
12. 堤岸坡脚或放坡堆積、泥漿土塊（泥漿土堆塊）之河床上，須先填整平。
13. 除另有註明者外，所有聯接兩排水設施間之溝底流線均視為圓緩坡度。
14. 所有鋼筋混凝土管須以廠製長度安裝，不得在工地切割。
15. 除圖上另有註明者外，鋼筋混凝土管採用企口接頭。
16. 排水管面而之埋設，應考慮沉陷問題及其拱勢，圖上所用高程，均係施工後高度。
17. 各排水井或集水井以及管路在埋設時，應特別小心不得有任何碎石落入其內，應隨時清理所積碎石以保持流水暢通。
18. 排水設施之混凝土及鋼筋混凝土之設計應力如下：

(1) 無筋混凝土（四袋裝）	
混凝土與卵石及墊層用	$f'_c = 140 \text{ KG/CM}^2$
普通基礎之底部	$f'_c = 80 \text{ KG/CM}^2$
(2) 無筋混凝土（五袋裝）	$f'_c = 180 \text{ KG/CM}^2$
(3) 鋼筋混凝土（七袋裝）	$f'_c = 240 \text{ KG/CM}^2$
(4) 鋼筋	$f_s = 1,400 \text{ KG/CM}^2$

19. 鋼筋直徑以公厘表示。
20. 除圖上另有註明者外，混凝土外圍之斜切緣角為2公分，其填角則為5公分。
21. 各種進水井之格柵應與主要地面水流向平行。所有格柵及格柵架應依規範設計。
22. 各種進水井之格柵、集水井或人孔之鐵梯，在高度12公尺以下時，在底版上40公分處設踏步一階，若高度在12公尺以上時，在距井（孔）頂30公分左右至底版上40公分之間，每隔30公分設一階步。
23. 混凝土砌石所用卵石直徑之差異，應在圖中所註直徑十分之一以內；其中較小尺寸者，不得超過30%，較大尺寸者，不得超過40%。卵石之長度應為其直徑之1.2~1.5倍，或卵石之寬與厚應為其長度之二分之一以上。

GENERAL NOTES

1. ALL DIMENSIONS SHOWN ON THE DRAINAGE PLAN ARE IN CENTIMETERS UNLESS OTHERWISE INDICATED.
2. ALL DISTANCES SHOWN ARE HORIZONTAL MEASUREMENT; AND ALL HORIZONTAL DIMENSIONS ARE AT RIGHT ANGLES.
3. THE EXACT PIPE, BOX CULVERT OR DITCH LOCATIONS, ELEVATIONS, SKEW ANGLE, AND TRANSITIONS SHALL BE VERIFIED BY THE ENGINEER IN THE FIELD.
4. THE CONTRACTOR SHALL VERIFY ALL DIMENSIONS, ELEVATIONS, ALIGNMENTS AND LOCATIONS SHOWN ON THE PLANS AND SHALL NOTIFY THE ENGINEER OF ANY AND ALL DISCREPANCIES PRIOR TO THE BEGINNING OF THE WORK.
5. FOR THE RELOCATION OF EXISTING IRRIGATION CANAL OR DRAINAGE CHANNEL, THE CONTRACTOR SHALL COOPERATE WITH RELATED AGENCIES THROUGH TAFCB IN ORDER THAT THE DRAINAGE AND IRRIGATION WILL BE FUNCTIONED PROPERLY DURING CONSTRUCTION.
6. THE REQUIRED LENGTH OF UNDERDRAINS (PERFORATED PVC PIPE) SHALL BE VERIFIED OR JUSTIFIED BY THE ENGINEER IN ACCORDANCE WITH GROUNDWATER CONDITION IN THE OPEN CUT AREA BEFORE SUBGRADE PREPARATION.
7. THE CONTRACTOR SHALL COOPERATE WITH THE RELATED AGENCIES THROUGH TAFCB FOR THE CONNECTION OF THE RELOCATION OR IMPROVEMENT OF IRRIGATION/DRAINAGE FACILITIES BY THE OTHERS AS SHOWN ON THE PLAN.
8. THE "BACKFILL WITH ROCK" OR "ROCK" SHOWN ON THE PLAN IS THE SAME PAY ITEM OF "RIPRAP".
9. UNLESS OTHERWISE INDICATED ON THE PLAN, THE LOCATION OF WEEPHOLES FOR DITCH OR WING WALL/END WALL SHALL BE DETERMINED BY THE ENGINEER.
10. THE STRUCTURAL BACKFILL ALONG THE CHANNEL IN HILLSIDE AREA SHALL BE GRADED TO THE ORIGINAL GROUND OR TO THE LEVEL AS DIRECTED BY THE ENGINEER. IF THE CHANNEL SECTION IS REQUIRED TO BE GRADED TO A PROPER GRADE AS DIRECTED BY THE ENGINEER, THE WORK SHALL BE DONE IN ACCORDANCE WITH SECTION: "CHANNEL EXCAVATION" OF SPECIFICATION.
11. UNLESS OTHERWISE INDICATED ON THE PLAN, THE CONSTRUCTION OF LEVEE AND LEVEE CORE SHALL BE OF EARTH EMBANKMENT.
12. THE RIVER AND/OR CHANNEL BED SHALL BE ROUGHLY GRADED ALONG THE TOE LINE OF BANK PROTECTION PRIOR TO THE PLACING OF WIRE SAUSAGES & CONCRETE BLOCK (TRILEG CONCRETE BLOCK).
13. UNLESS OTHERWISE INDICATED, THE FLOW LINE OF DITCHES SHALL BE A STRAIGHT FLOWING GRADIENT BETWEEN TWO POINTS OR FACILITIES WITH WHICH THEY JOIN.
14. ALL RC PIPE SHALL BE FURNISHED AND INSTALLED IN MANUFACTURED LENGTH WITHOUT FIELD CUT.
15. UNLESS OTHERWISE INDICATED ON THE PLAN, THE RC PIPE JOINTS SHALL BE OF TONGUE AND GROOVE TYPE.
16. THE CONSTRUCTION OF DRAINAGE CULVERTS SHALL BE CONSIDERED ON STRUCTURAL SETTLEMENT. ELEVATIONS SHOWN ON THE PLANS ARE THE FORMATION LEVEL.
17. THE CONTRACTOR SHALL PAY FULL ATTENTION TO THAT NO DIRT OR GRAVEL SHALL BE ALLOWED TO FALL INTO INLETS, CATCH BASIN OR PIPE LINES DURING CONSTRUCTION. TO CLEAN OUT ANY SEDIMENT AND TO KEEP FLOW FREE.
18. DESIGN STRESS AND STRENGTH OF CONCRETE AND REINFORCED CONCRETE FOR DRAINAGE FACILITIES

(1) PLAIN CONCRETE (4 SACKS) FOR CONCRETE GROUTED ROCK AND CONCRETE BEDDING FOR BASEMENT	$f'_c = 140 \text{ KG/CM}^2$ $f'_c = 80 \text{ KG/CM}^2$
(2) PLAIN CONCRETE (5 SACKS)	$f'_c = 180 \text{ KG/CM}^2$
(3) REINFORCED CONCRETE (7 SACKS)	$f'_c = 240 \text{ KG/CM}^2$
(4) REINFORCING STEEL BARS	$f_s = 1,400 \text{ KG/CM}^2$
19. ALL REINFORCING STEEL BARS ARE SIZED IN MILLIMETERS AND SHALL BE OF DEFORMED BARS
20. FOR CONCRETE STRUCTURES, ALL EXPOSED SHARP EDGES SHALL BE CHAMFERED 2 CM AND ALL FILLETS SHALL BE 5 CM, UNLESS OTHERWISE NOTED ON THE PLAN.
21. INLETS SHALL BE SO PLACED THAT GRATE BARS ARE PARALLEL TO DIRECTION OF PRINCIPAL SURFACE FLOW. ALL GRATES AND FRAMES SHALL BE GALVANIZED IN ACCORDANCE WITH SPECIFICATION.
22. FOR INLETS, CATCH BASINS OR MANHOLES, INSTALL ONE GALVANIZED IRON STEP 0.4 M ABOVE FLOOR WHEN THE STRUCTURE'S HEIGHT IS LESS 1.2 M, AND IF IT IS OVER 1.2 M, STEPS SHALL BE SPACED AT EVENLY 0.3 M FROM 0.4 M ABOVE FLOOR UP TO WITHIN 0.3 M BELOW THE TOP OF THE STRUCTURE.
23. THE ROCK DIAMETER VARIATION OF CONCRETE GROUTED ROCK WILL BE ALLOWED WITHIN ONE-TENTH OF THAT INDICATED ON THE PLANS. THE SMALLER SIZE SHALL NOT BE MORE THAN 30%, AND THE LARGER SIZE SHALL NOT BE MORE THAN 40%. THE LONGITUDINAL DIMENSION OF THE ROCK SHALL BE 1.2 - 1.5 TIMES THE TRANSVERSE DIMENSION, OR THE ROCK WIDTH AND HEIGHT ARE MORE THAN ONE HALF OF THE LENGTH.

修正 項目	REVISIONS 日期	交通部台灣區高速公路工程局 TAIWAN AREA FREEWAY CONSTRUCTION BUREAU 中華民國 南北高速公路 苗栗台中段
		NORTH-SOUTH FREEWAY MIAOLI-TAICHUNG SECTION
		排水設施總說明 DRAINAGE PLAN GENERAL NOTES
		中華顧問工程司 CHINA ENGINEERING CONSULTANTS, INC.
		日期 DATE AUG. '74 比例 SCALE NONE 圖號 SHEET DT-1

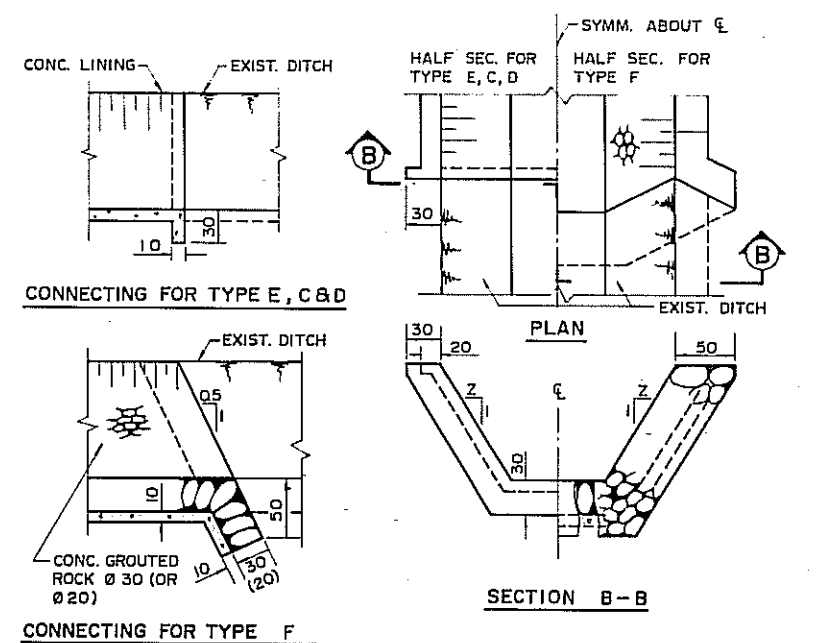
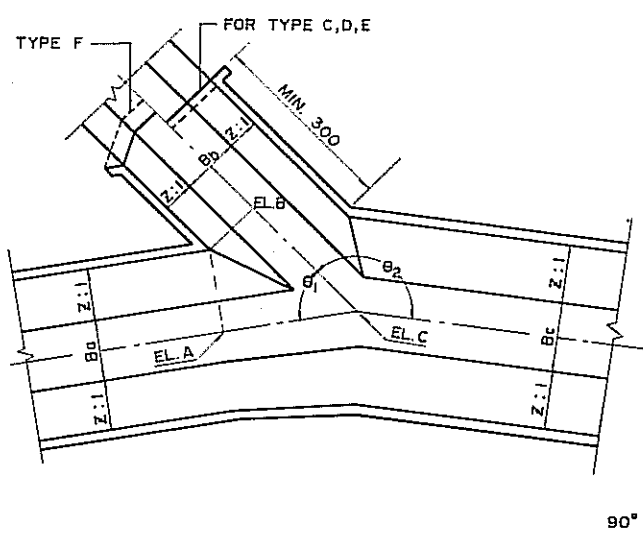
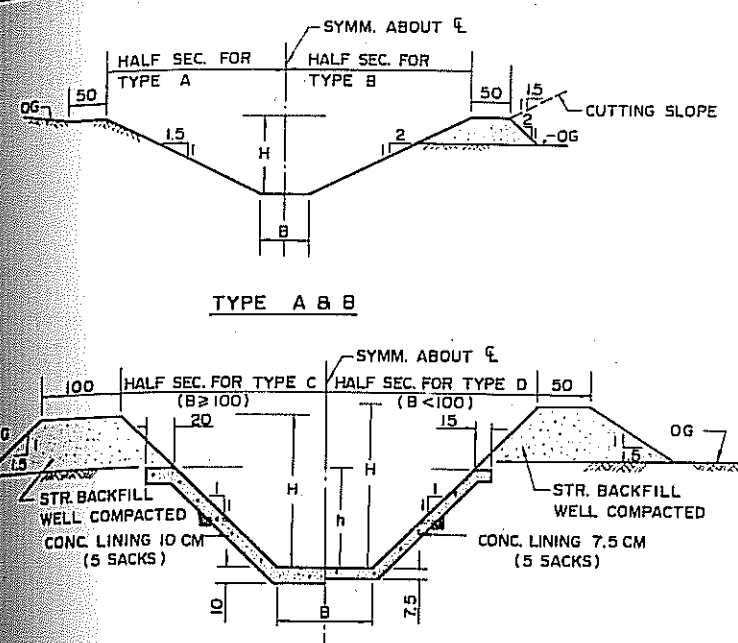

TYPICAL LAYOUT OF DITCH JUNCTIONS

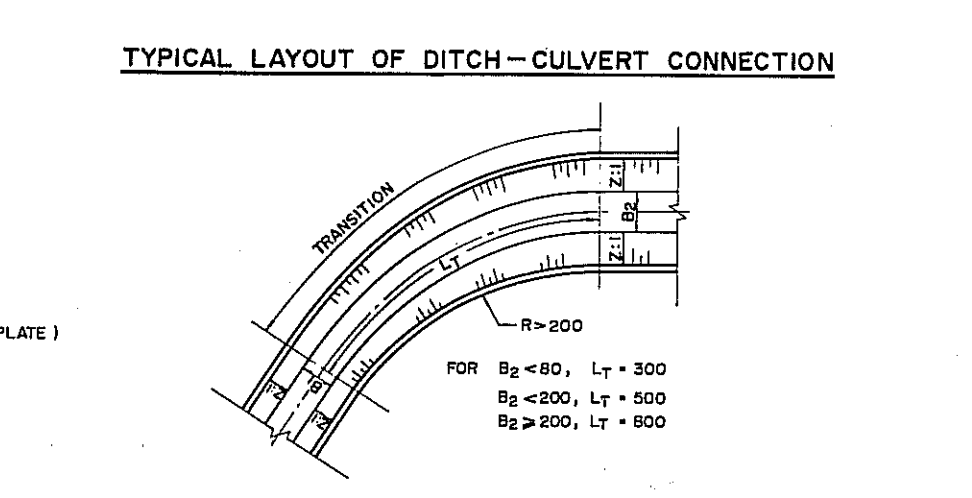
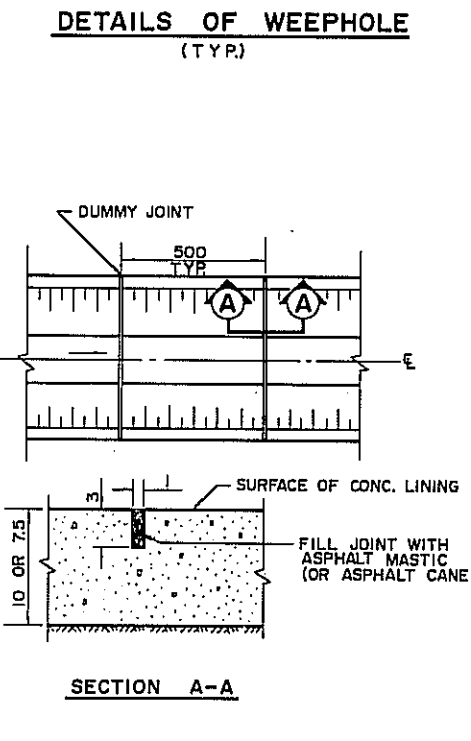
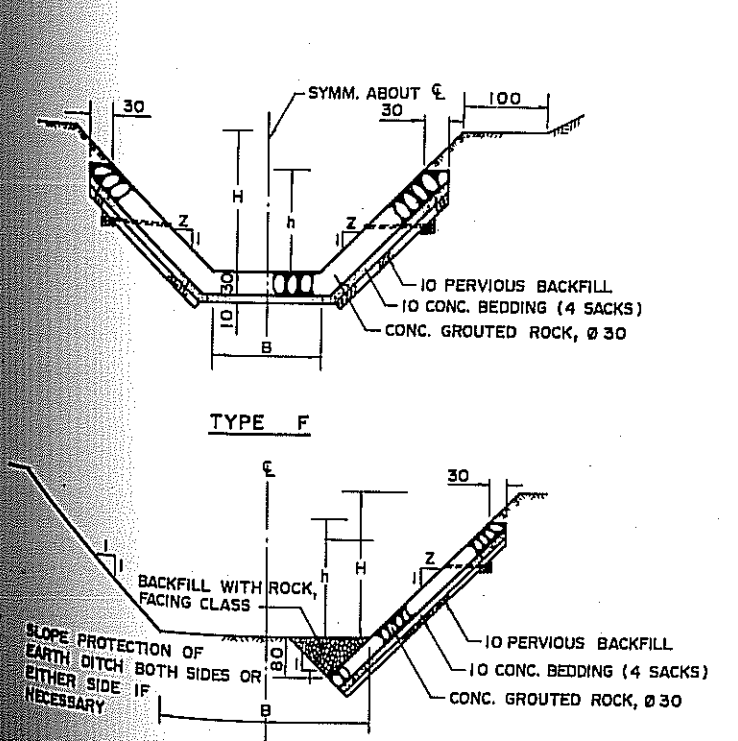
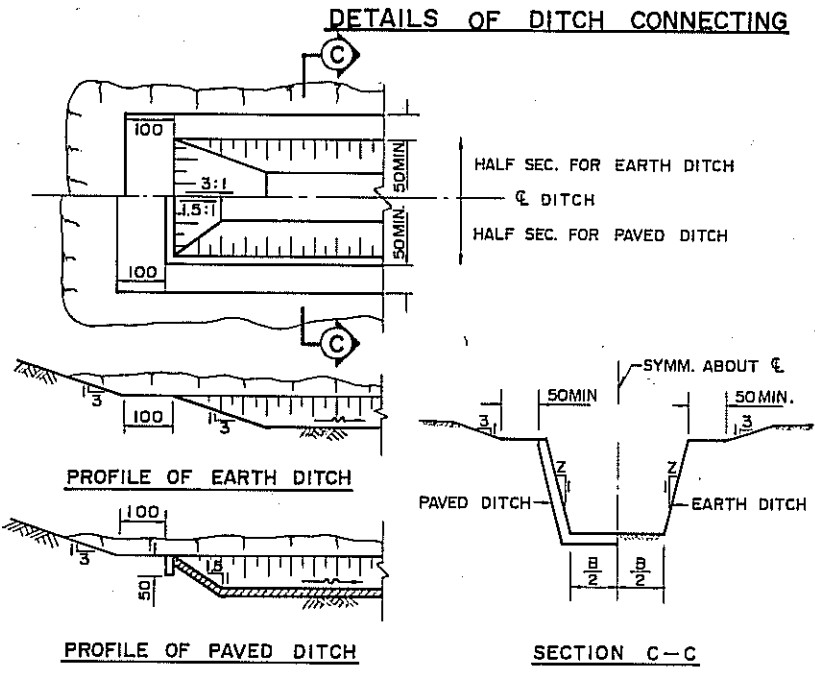
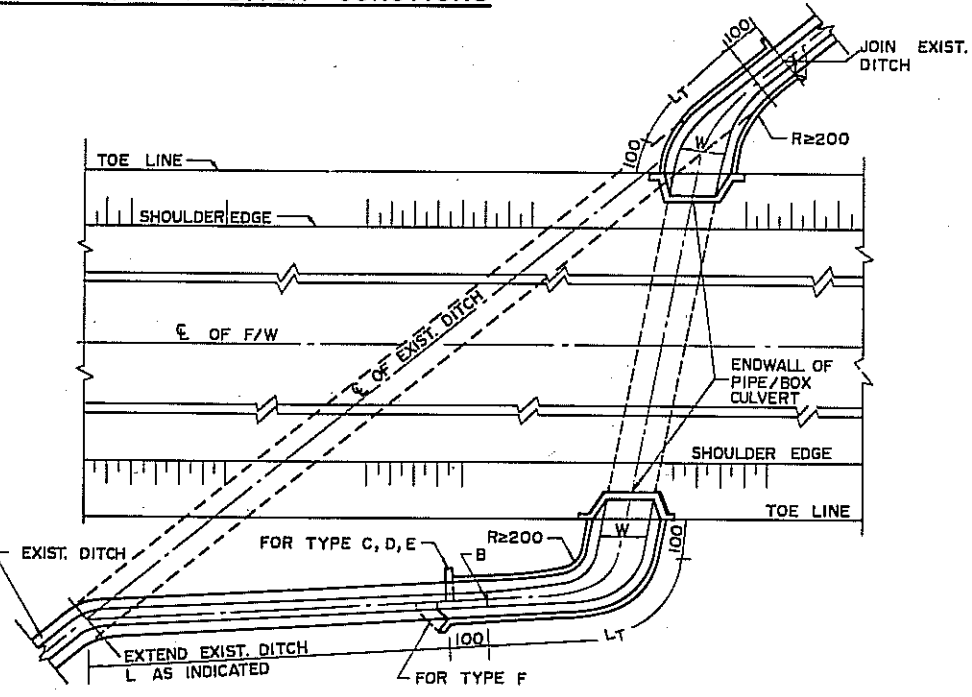
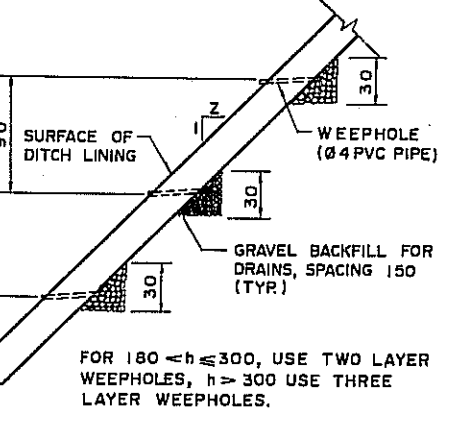
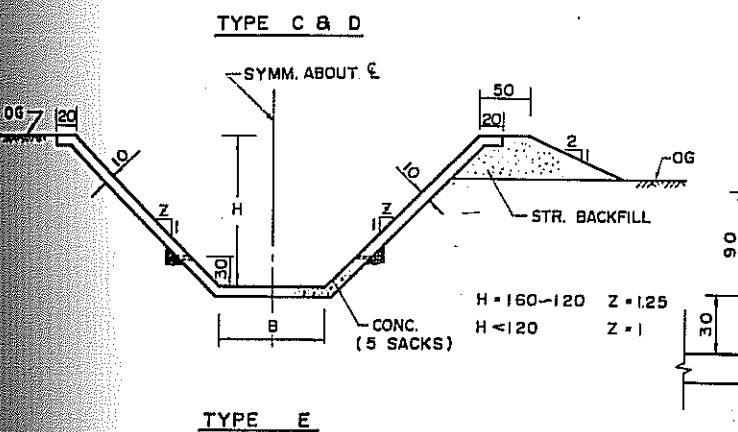

BEGINNING POINT OF DITCH

DETAILS OF DUMMY JOINT FOR CONC. LINING

LAYOUT OF TRANSITION

修正 REVISIONS		REVISIONS	
項目 ITEM	日期 DATE	項目 ITEM	日期 DATE

交通部台灣區高速公路工程局
TAIWAN AREA FREEWAY CONSTRUCTION BUREAU
中華民國 REPUBLIC OF CHINA

南北高速公路 NORTH-SOUTH FREEWAY
苗栗台中段 MIAOLI-TAICHUNG SECTION

明溝及掘斷面 DITCH SECTIONS

中華顧問工程司 CHINA ENGINEERING CONSULTANTS, INC.
日期 DATE AUG. '74 比例 SCALE NTS 圖號 SHEET DT-2/

DIMENSIONS AND QUANTITIES

(FOR ONE ENDWALL ONLY)

INSIDE DIAMETER OF PIPE D	DIMENSIONS							QUANTITIES			
	A	B	C	E	F	G	H	CONC. 7 SACKS/M ³	STEEL REINF. BARS (KG)	STR. EXC. (M ³)	ROCK, FACING CLASS (M ³)
80	117	15	173	298	150	75	40	1.27	21	1.40	0.60
100	147	20	173	332	150	75	60	1.97	82	1.80	0.70
120	169	20	220	400	190	95	60	2.73	103	2.40	0.80
150	207	20	242	458	210	105	80	3.50	127	2.90	1.00

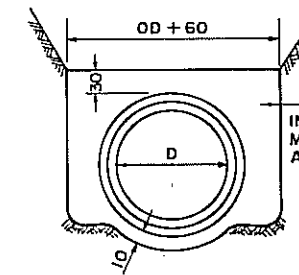

TYPICAL PIPE BEDDING DETAIL

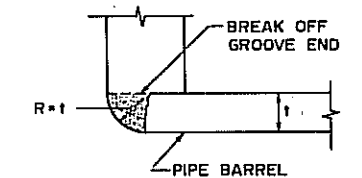

ROUNDED ENTRANCE (AT INLET ENDWALL ONLY)

TABLE OF REINFORCEMENT BARS

(FOR ONE ENDWALL)

MARK	SIZE MM	Ø 80		Ø 100		Ø 120		Ø 150	
		NO.	LENGTH EACH BAR	NO.	LENGTH EACH BAR	NO.	LENGTH EACH BAR	NO.	LENGTH EACH BAR
L1	13Ø	10	80	-	-	-	-	-	-
L2	16Ø	-	-	2	137	2	139	2	157
L3	16Ø	-	-	2	150	2	152	2	170
L4	16Ø	-	-	2	163	2	165	2	183
L5	16Ø	-	-	2	176	2	178	2	196
L6	16Ø	-	-	2	189	2	192	2	209
L7	16Ø	-	-	2	202	2	206	2	222
L8	16Ø	-	-	-	-	2	222	2	235
L9	16Ø	-	-	-	-	-	-	2	250
M1	16Ø	-	-	1	156	1	180	1	212
M2	16Ø	-	-	1	170	1	190	1	230
M3	13Ø	-	-	1	220	1	245	1	280
M4	13Ø	-	-	1	270	1	295	1	330
M5	13Ø	-	-	-	-	1	342	1	380
M6	13Ø	-	-	-	-	-	-	1	415
M7	13Ø	-	-	2	322	2	390	2	448
N	13Ø	6	90	7	115	8	115	9	115
P1	13Ø	-	-	2	178	2	228	2	250
P2	13Ø	-	-	2	160	2	210	2	232
U1	13Ø	1	482	-	-	-	-	-	-
U2	16Ø	-	-	2	512	2	640	2	720
W	13Ø	-	-	2	143	2	190	2	212

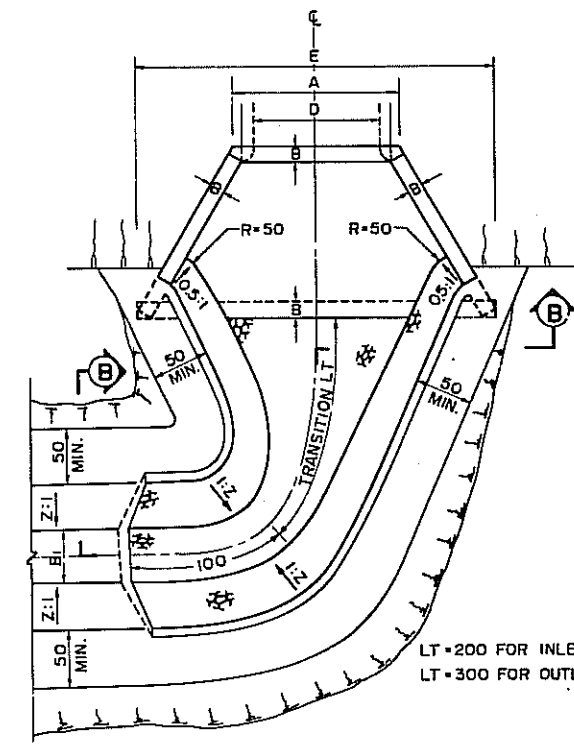

PLAN

FOR RCP D=80 B1=40, h=60
FOR RCP D=100 B1=50, h=80

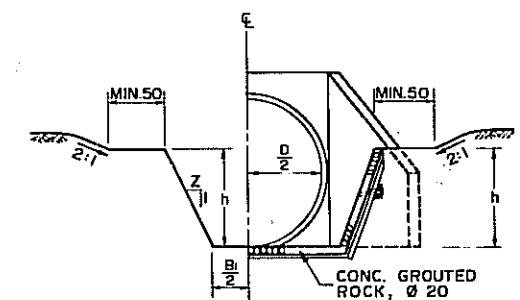

SECTION B-B

ENDWALL TYPE A2

(WITH CONC. GROUTED ROCK TRANSITION FOR RCP Ø80 & Ø100 ONLY)

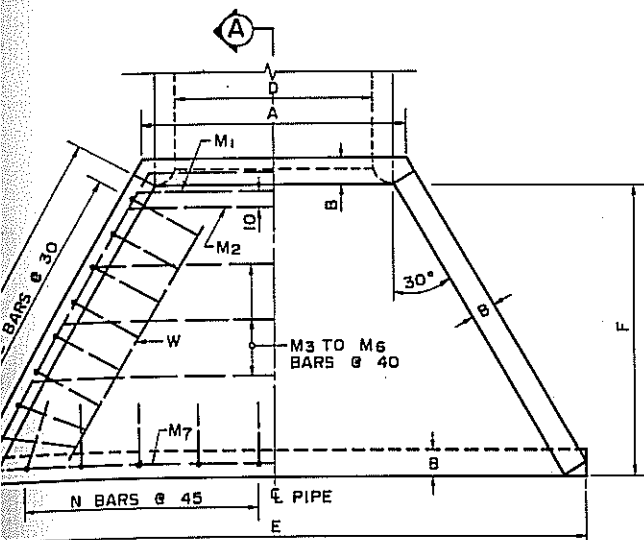

PLAN

(HALF SHOWING REINFORCEMENT BARS)

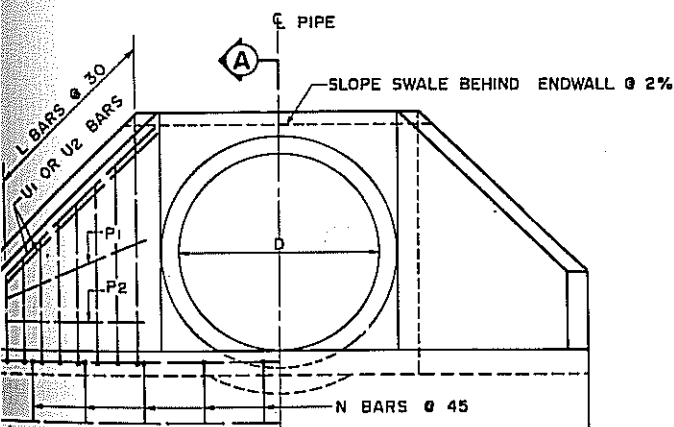

END VIEW

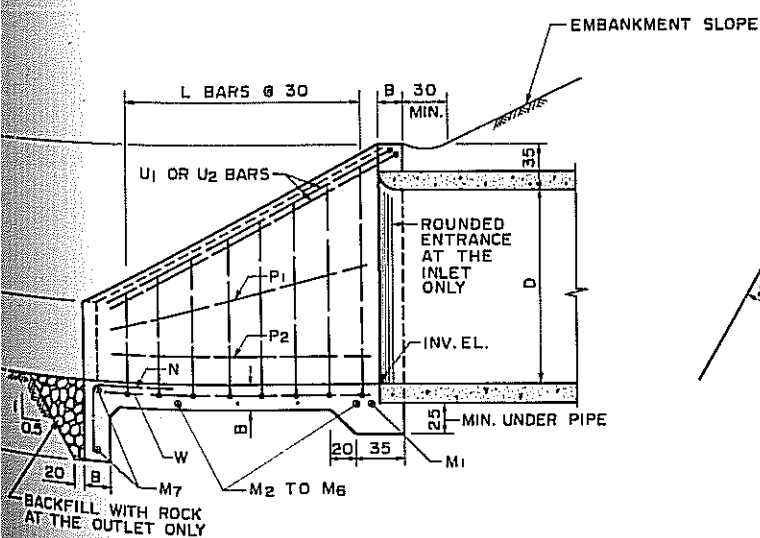

SECTION A-A

ENDWALL TYPE A1

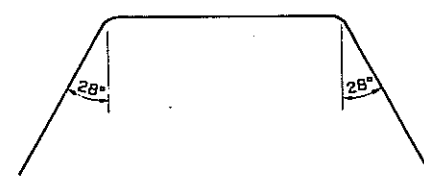

BARS U1 OR U2

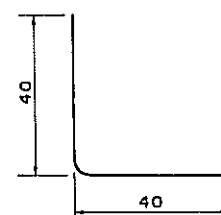

L1 BARS

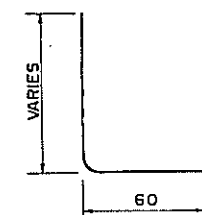

BARS L2 TO L9

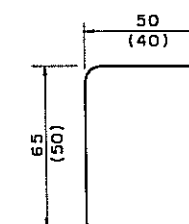

N BARS
(FIGURES IN PARENTHESIS FOR RCP Ø 80)

REINFORCEMENT FOR BENDING DETAILS

(BENT IN FIELD)

DRAINAGE STANDARD DETAILS

修正 REVISIONS	項目 ITEM	日期 DATE

交通部台灣區高速公路工程局
TAIWAN AREA FREEWAY CONSTRUCTION BUREAU
中華民國
南北高速公路 NORTH-SOUTH FREEWAY
苗栗台中段 MIAOLI-TAICHUNG SECTION
單管管涵A型端牆 SINGLE RCP CULVERT
ENDWALL, TYPE A
中華顧問工程司 CHINA ENGINEERING CONSULTANTS, INC.
日期 DATE AUG. '74 比例 SCALE NTS 圖號 SHEET DT - 3

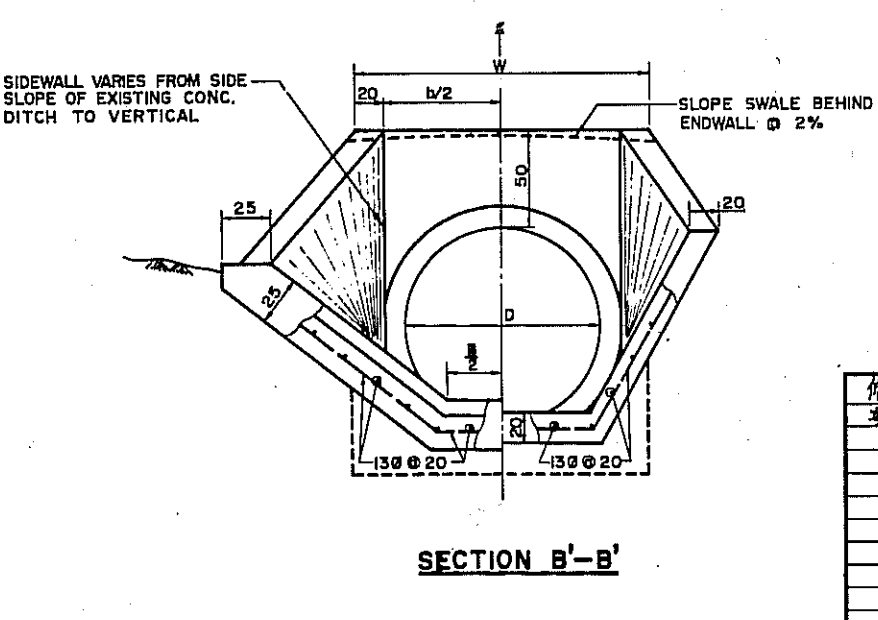
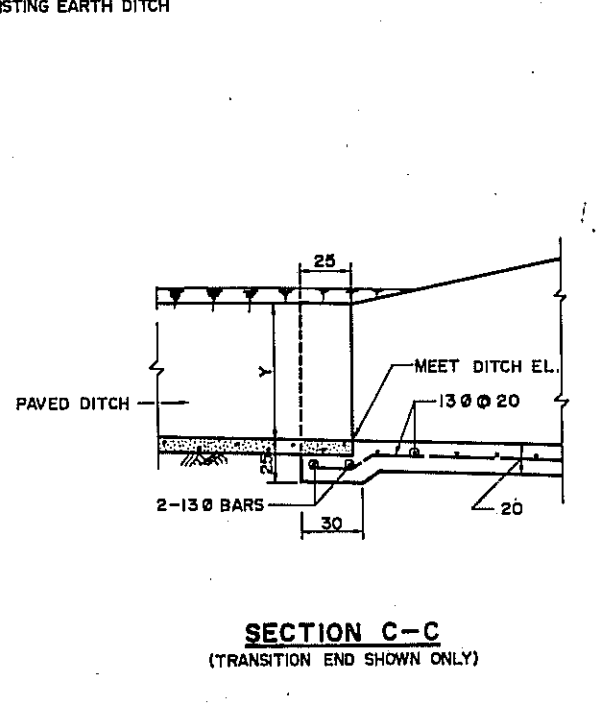
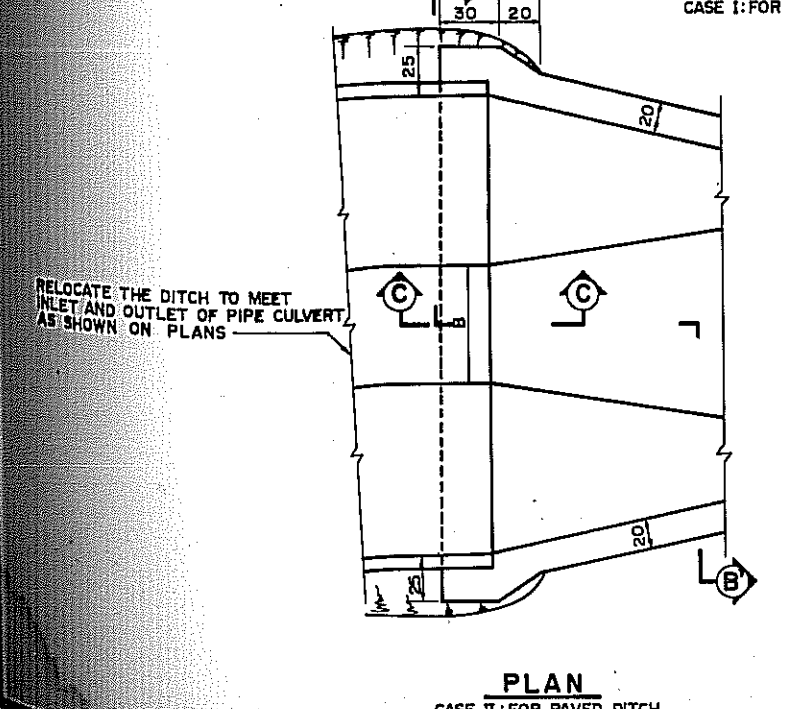
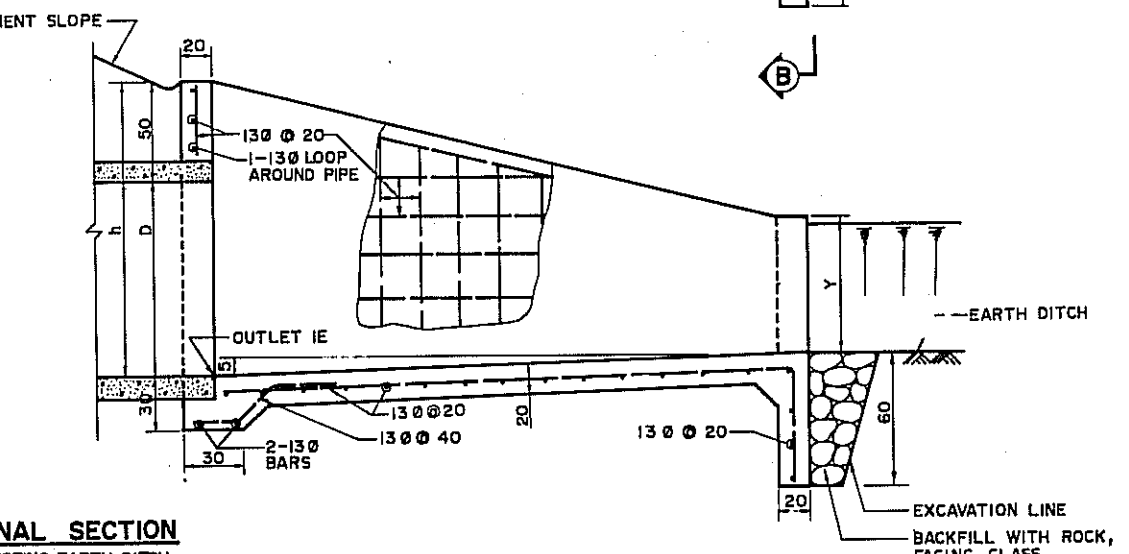
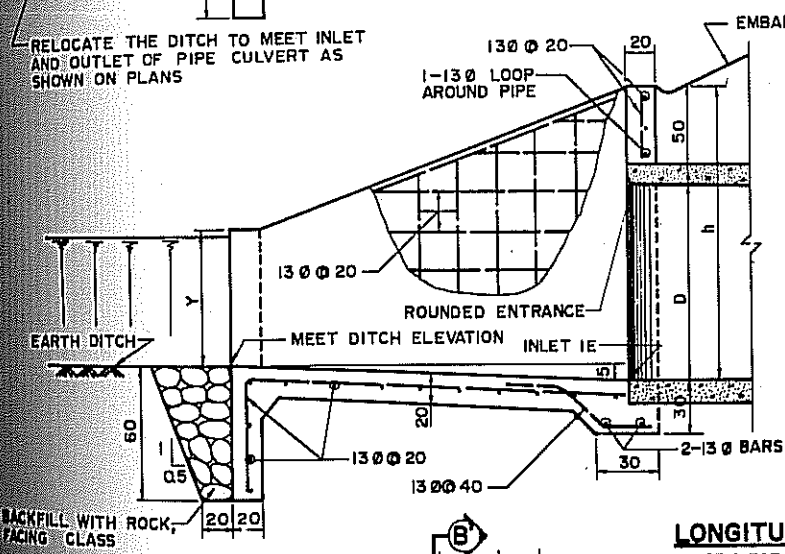
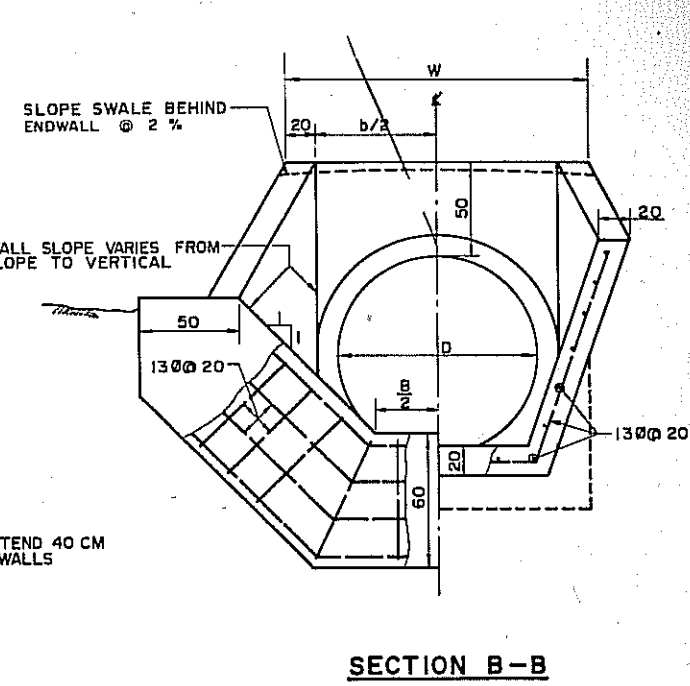
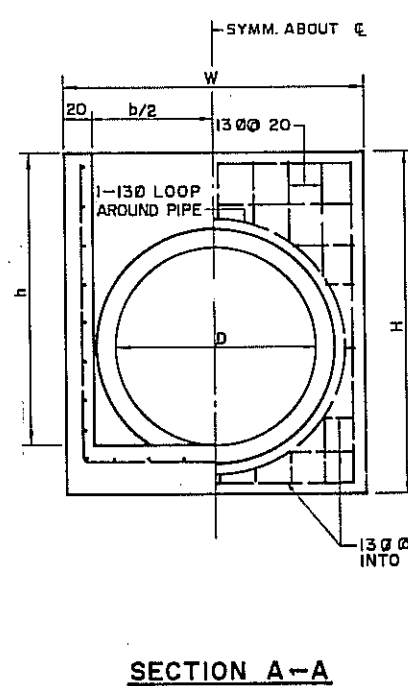
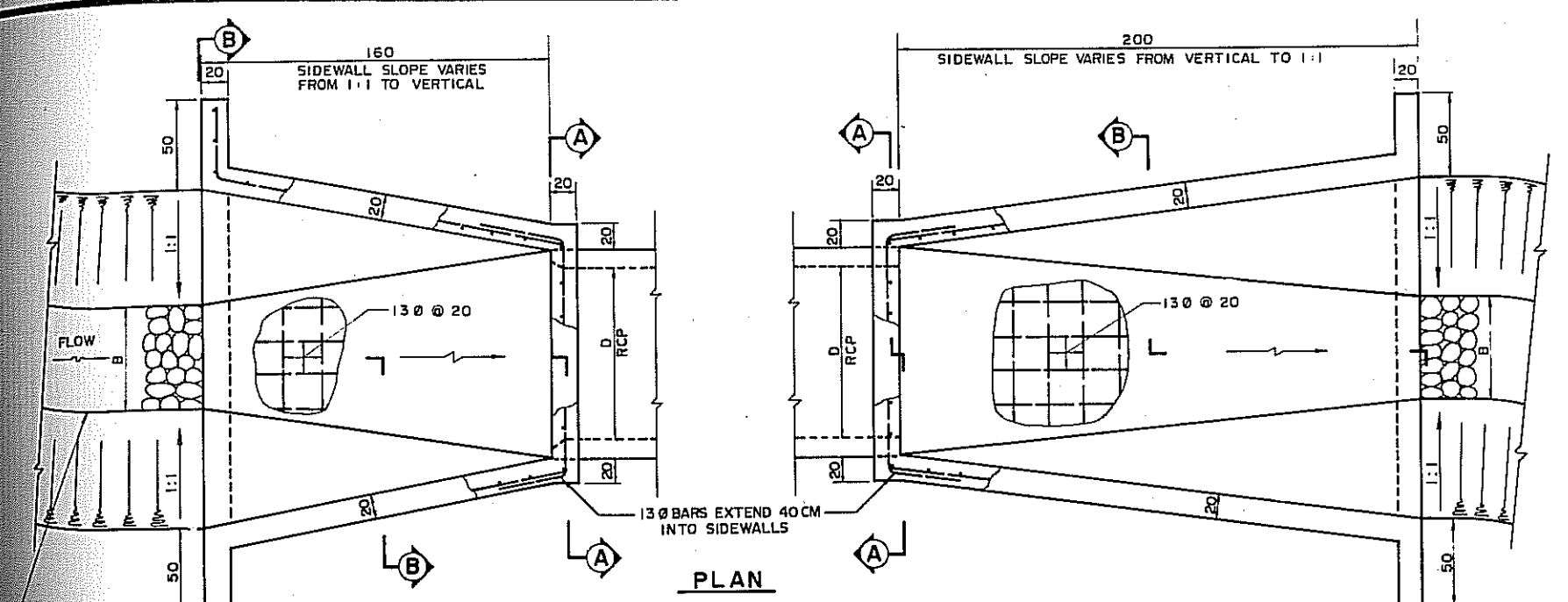

SEE SH. DT-3 FOR PIPE BEDDING DETAILS

TABLE OF DIMENSIONS

RCP D	Y	W	b	H	h	B*
120	100	186	146	200	170	60
150	120	224	184	230	200	80

* WIDTH OF EXIST. DITCH MAY SLIGHTLY DIFFER WITH THE FIGURES SHOWN IN THE TABLE.

DRAINAGE STANDARD DETAILS

修正 REVISIONS	項目 ITEM	日期 DATE

交通部台灣區高速公路工程局
TAIWAN AREA FREEWAY CONSTRUCTION BUREAU
中華民國
REPUBLIC OF CHINA
南北高速公路
MIAOLI-TAICHUNG SECTION
苗栗台中段
單管管涵B型端牆
SINGLE RCP CULVERT
ENDWALL, TYPE B
中華顧問工程司
CHINA ENGINEERING CONSULTANTS, INC.
日期 DATE AUG. '74 比例 SCALE NTS 圖號 SHEET DT-5

DIMENSIONS AND QUANTITIES

(FOR ONE ENDWALL ONLY)

INSIDE DIAMETER OF PIPE D	DIMENSIONS								QUANTITIES			
	A	B	C	E	F	G	H	K	CONC. 7 SACKS/M ³	STEEL REINF. BARS (KG)	STR. EXC. (M ³)	ROCK, FACING CLASS (M ³)
80	267	150	15	173	150	450	75	40	1.96	51	2.20	0.90
100	316	170	20	173	150	500	75	60	3.08	106	3.00	1.10
120	358	190	20	220	190	590	95	60	4.10	135	3.80	1.20
150	437	235	20	242	210	690	105	80	5.17	168	4.80	1.50

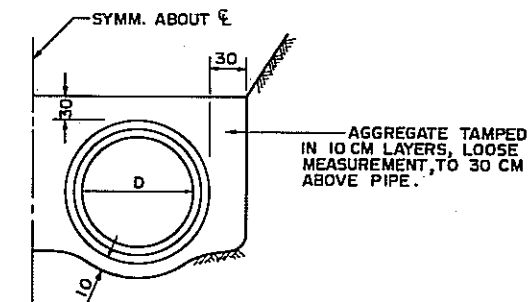

TYPICAL PIPE BEDDING DETAIL

TABLE OF REINFORCEMENT BARS

(FOR ONE ENDWALL ONLY)

MARK	SIZE MM.	Ø 80		Ø 100		Ø 120		Ø 150	
		NO.	LENGTH EACH BAR	NO.	LENGTH EACH BAR	NO.	LENGTH EACH BAR	NO.	LENGTH EACH BAR
L ₁	13 Ø	2	90	—	—	—	—	—	—
L ₂	16 Ø	2*	124	2	137	2	137	2	157
L ₃	16 Ø	2*	136	2	150	2	151	2	170
L ₄	16 Ø	2*	152	2	163	2	165	2	183
L ₅	16 Ø	2*	165	2	176	2	179	2	196
L ₆	16 Ø	—	—	2	189	2	193	2	209
L ₇	16 Ø	—	—	2	202	2	207	2	222
L ₈	16 Ø	—	—	—	—	2	222	2	235
L ₉	16 Ø	—	—	—	—	—	—	2	250
L ₁₀	16 Ø	2	185	2	205	2	225	2	255
M ₁	16 Ø	1	280	1	325	1	368	1	440
M ₂	16 Ø	—	—	1	340	1	380	1	455
M ₃	13 Ø	—	—	1	390	1	425	1	500
M ₄	13 Ø	—	—	1	445	1	470	1	545
M ₅	13 Ø	—	—	—	—	1	520	1	590
M ₆	13 Ø	1	410	—	—	—	—	1	635
M ₇	13 Ø	2	440	2	490	2	580	2	680
N	13 Ø	9	90	10	115	12	115	16	115
P ₁	13 Ø	—	—	2	178	2	228	2	250
P ₂	13 Ø	—	—	2	160	2	210	2	232
U ₁	13 Ø	1	632	—	—	—	—	—	—
U ₂	16 Ø	—	—	2	680	2	830	2	950
W	13 Ø	—	—	2	145	2	190	2	212

* USE 13 Ø BARS

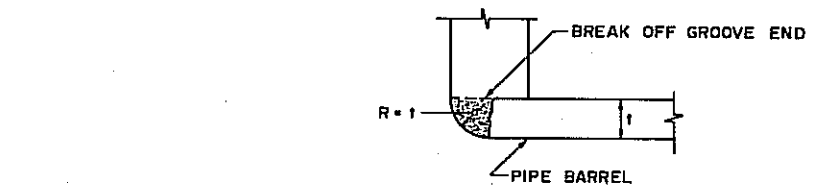

ROUNDED ENTRANCE

(AT INLET ENDWALL ONLY)

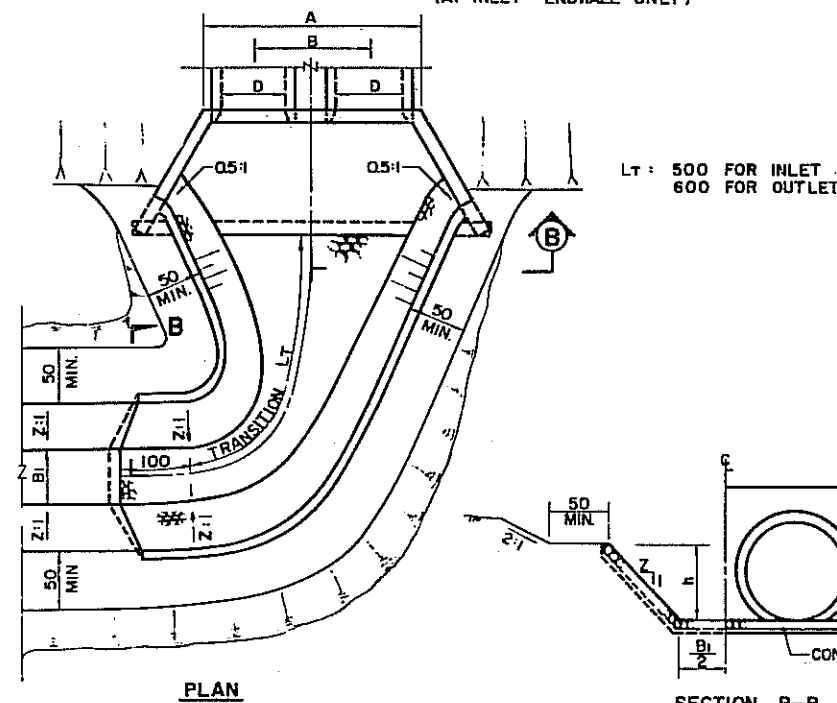

TYPE AA₂

DRAINAGE STANDARD DETAILS

修正 REVISIONS	項目 ITEM	日期 DATE

交通部台湾區高速公路工程局
TAIWAN AREA FREEWAY CONSTRUCTION BUREAU
中華民國
南北高速公路
MIAOLI-TAICHUNG SECTION
雙管涵AA型端牆
DOUBLE RCP CULVERT ENDWALL, TYPE AA
中華顧問工程司
CHINA ENGINEERING CONSULTANTS, INC.
日期 DATE AUG. '74 比例 SCALE NTS 圖號 SHEET DT-6

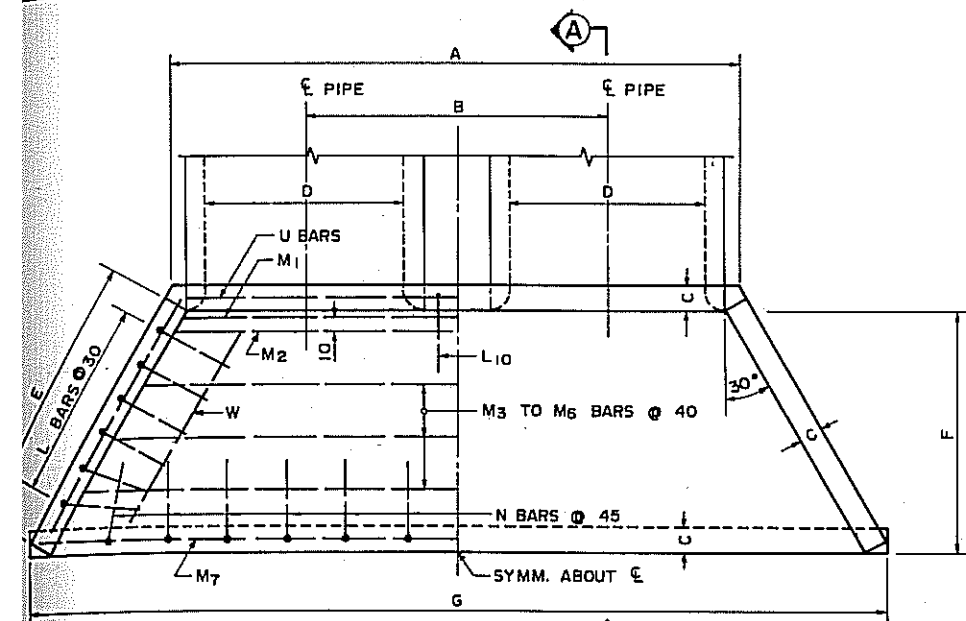

PLAN

(HALF SHOWING REINFORCEMENT BARS)

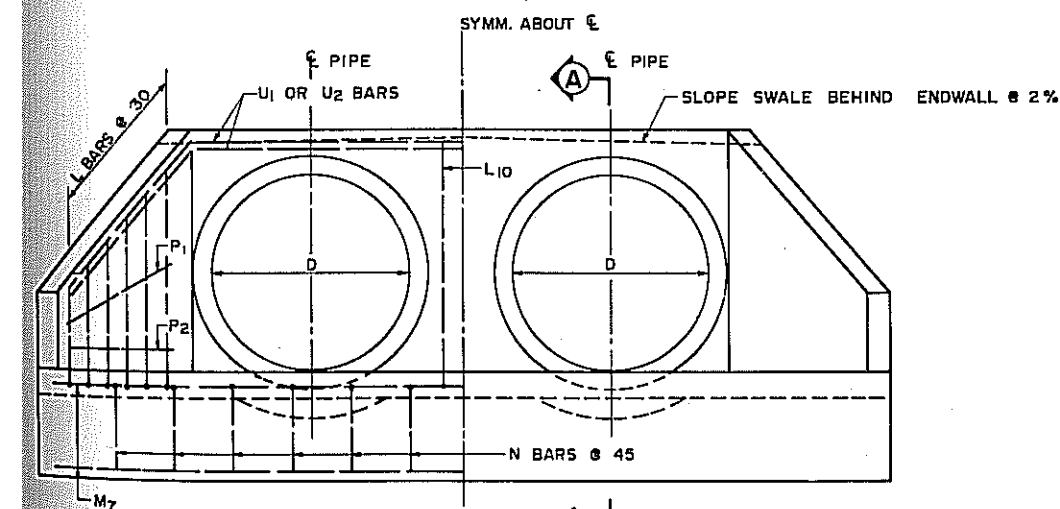

END VIEW

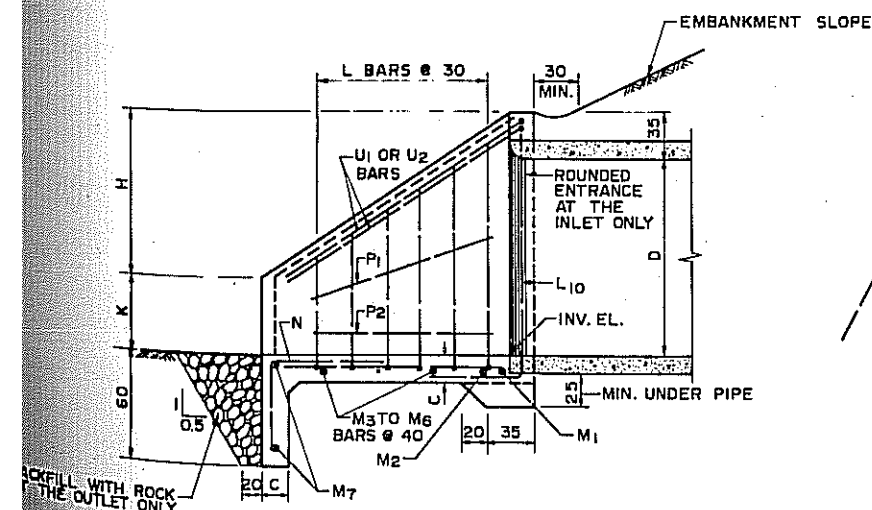

SECTION A-A

TYPE AA₁

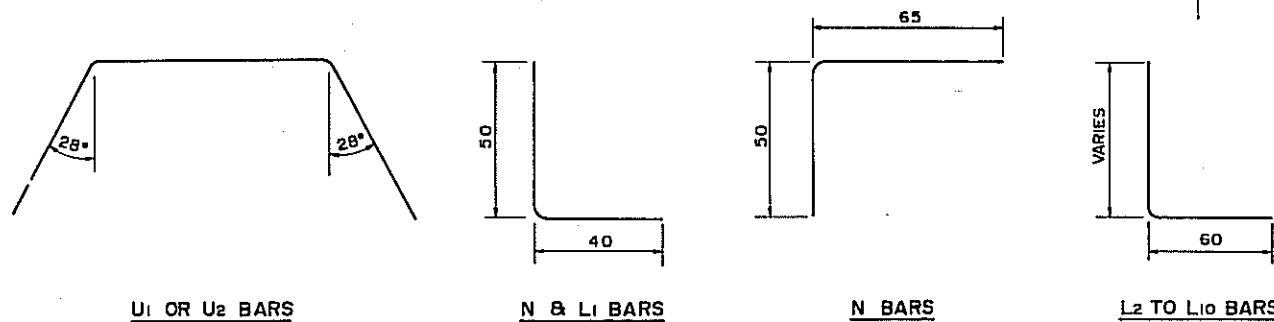

REINFORCEMENT FOR BENDING DETAILS

(BENT IN FIELD)

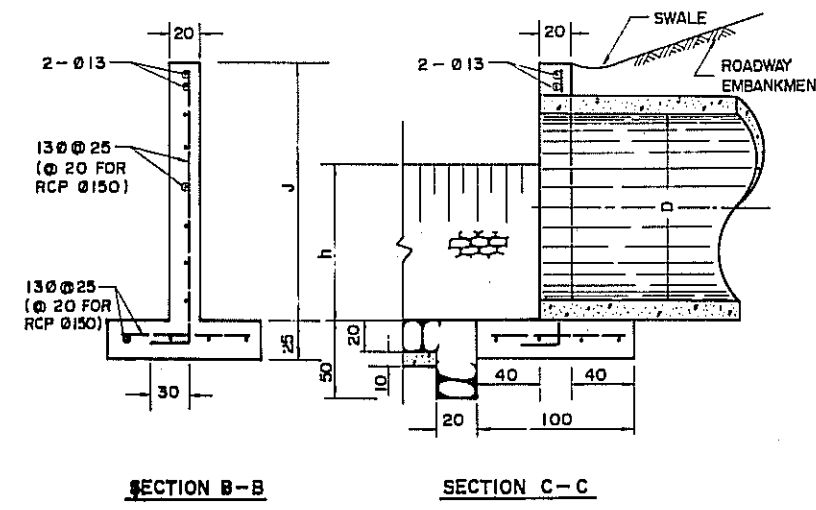
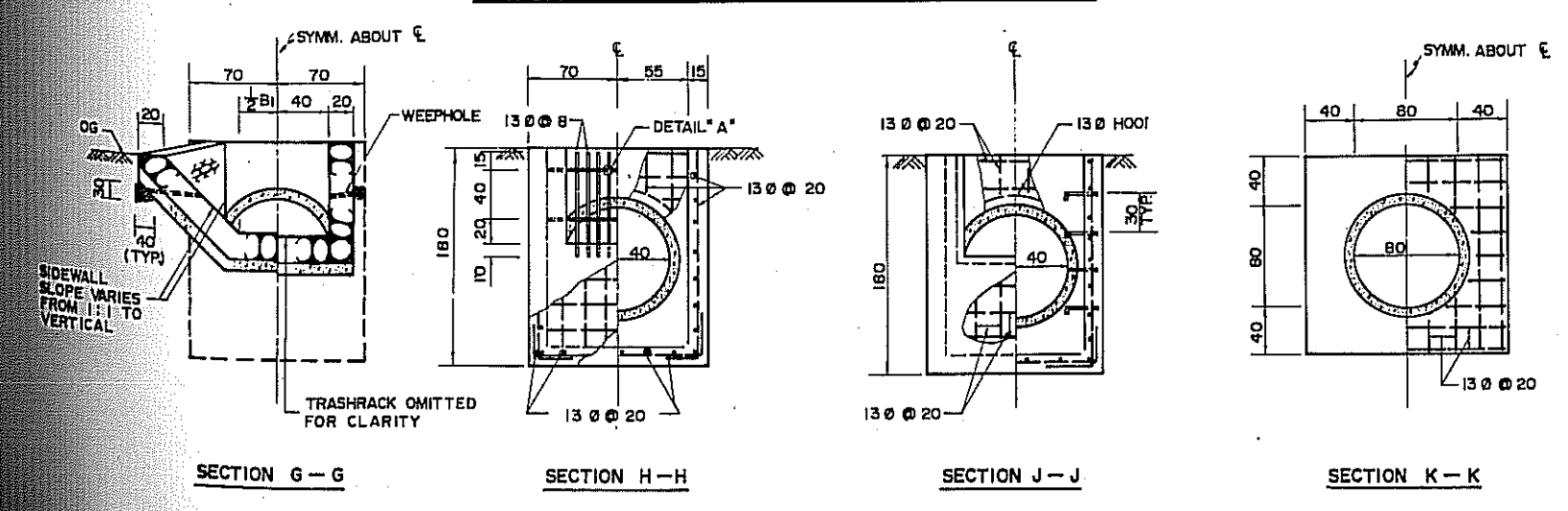
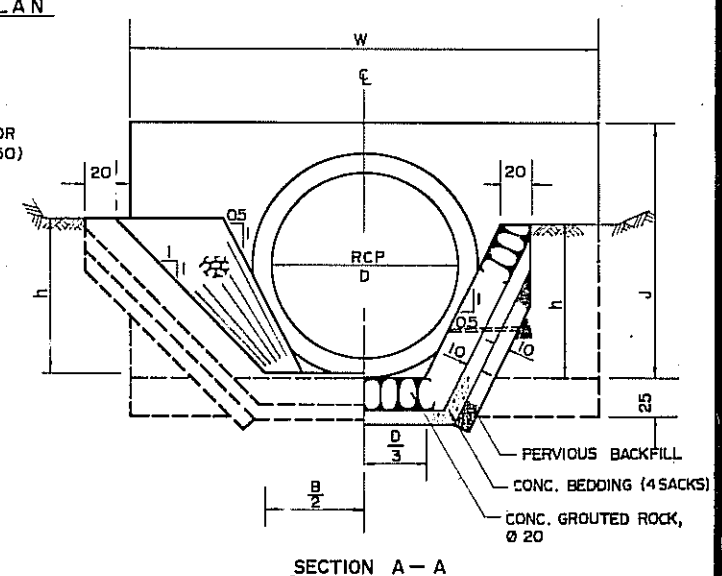
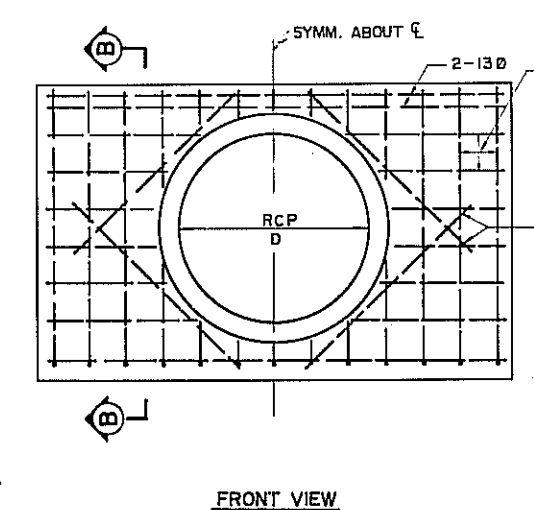
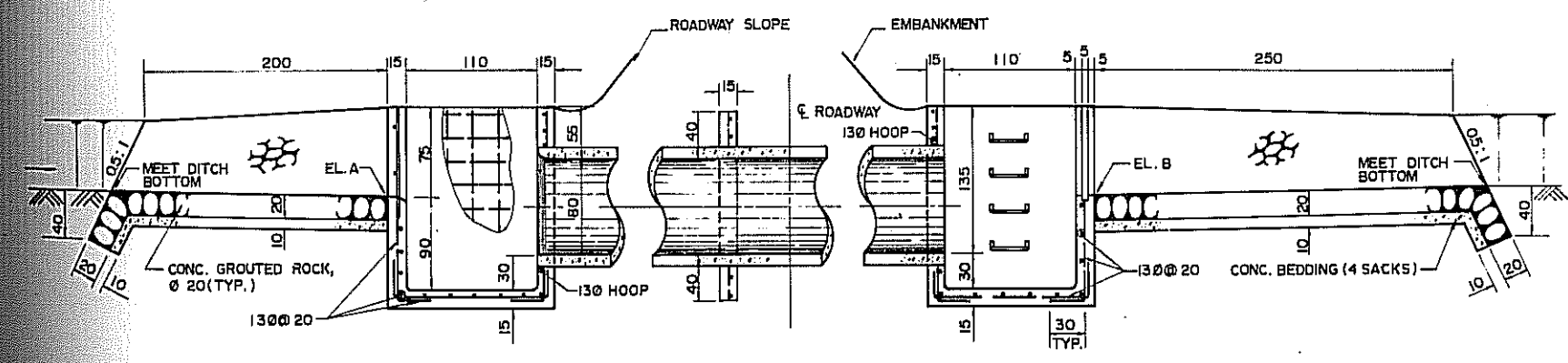
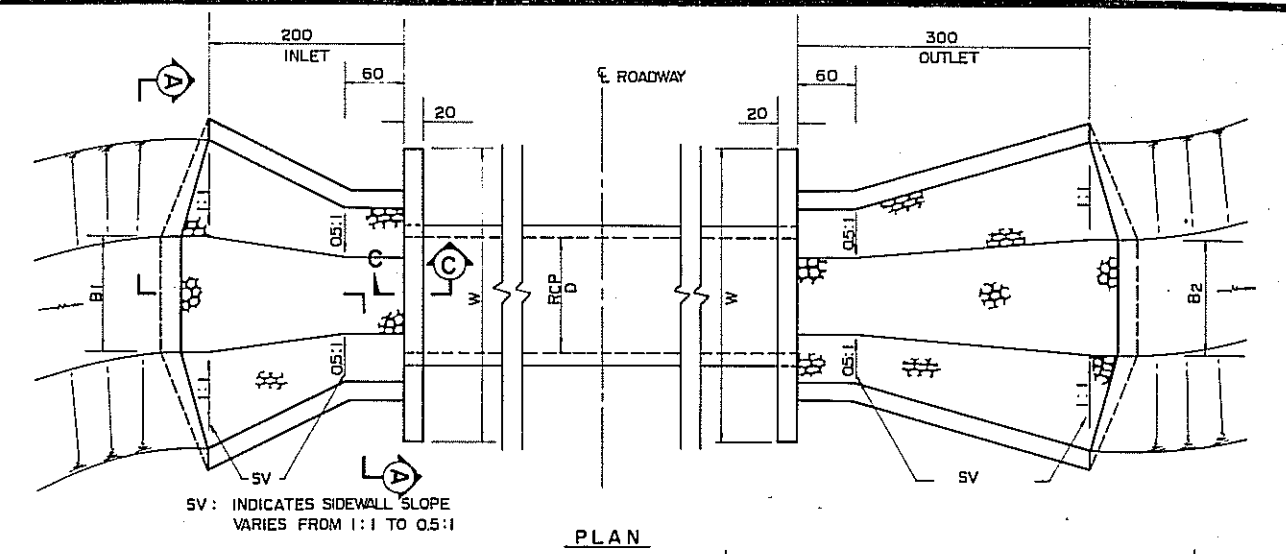
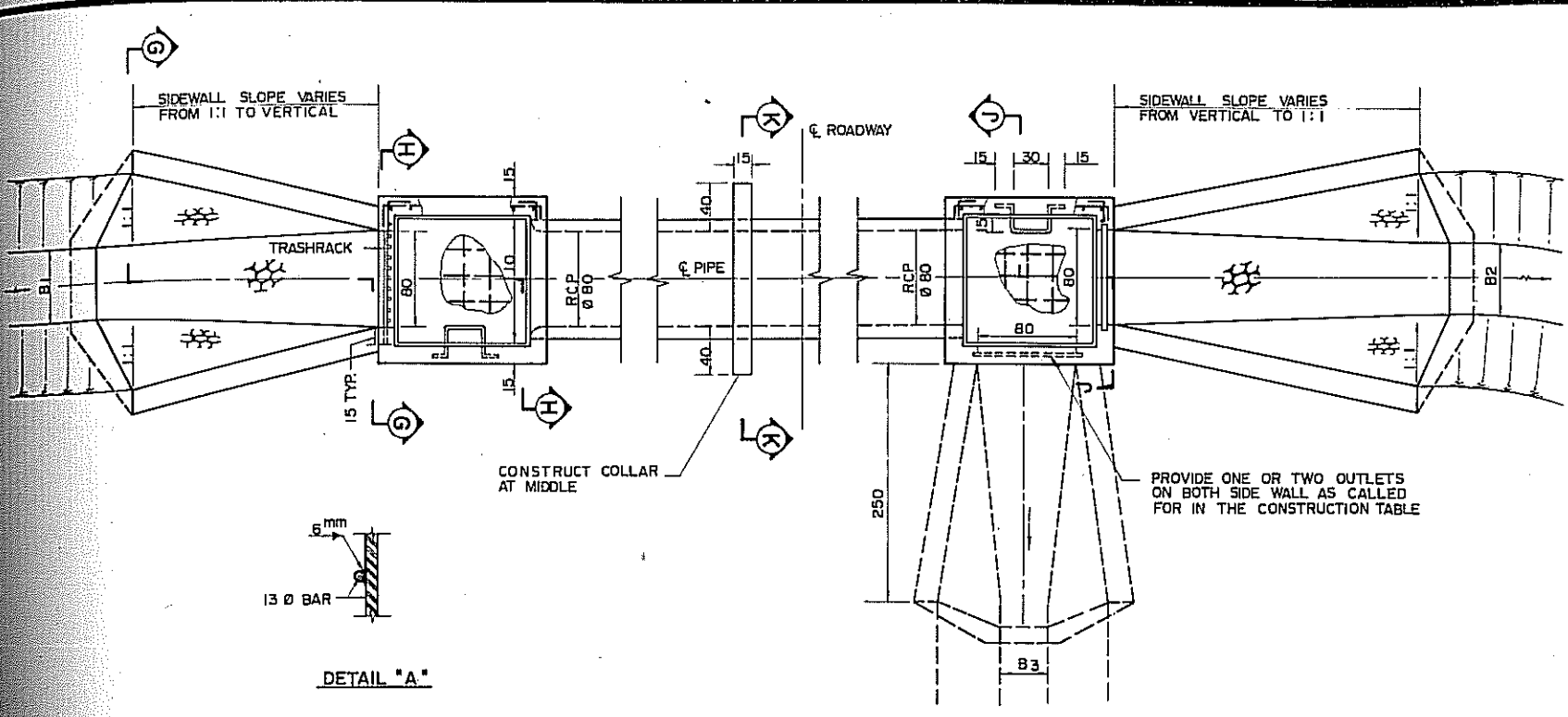

DIMENSION OF ENDWALL TYPE C

RCP D.	J	w	h
Ø 60	100	165	50
Ø 80	120	210	60
Ø 100	145	260	80
Ø 120	165	305	100
Ø 150	205	360	120

RCP CULVERT ENDWALL TYPE C DRAINAGE STANDARD DETAILS

修正 REVISIONS	項目 ITEM	日期 DATE

交通部台灣區高速公路工程局
TAIWAN AREA FREEWAY CONSTRUCTION BUREAU
中華民國
南北高速公路 NORTH-SOUTH FREEWAY
苗栗台中段 MIAOLI-TAICHUNG SECTION
橫交虹吸工及管涵C型端牆 CROSS-SIPHON & RCP CULVERT ENDWALL, TYPE C
中華顧問工程司 CHINA ENGINEERING CONSULTANTS, INC.
日期 DATE AUG. '74 比例 SCALE NTS 圖號 SHEET DT-8

SEE SHT. DT-3 FOR PIPE BEDDING DETAILS

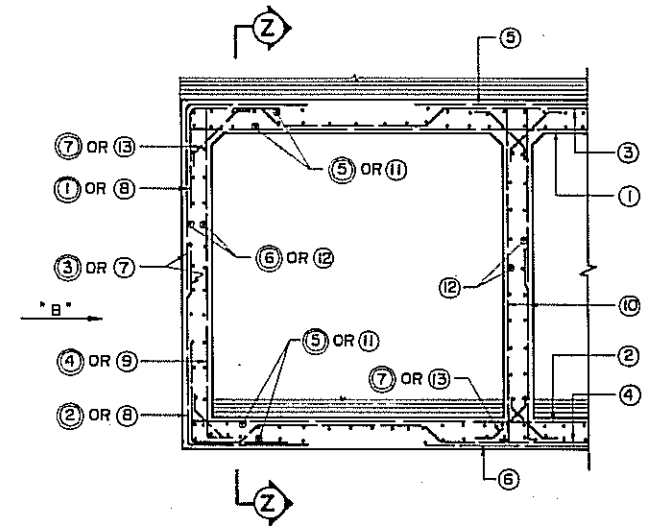
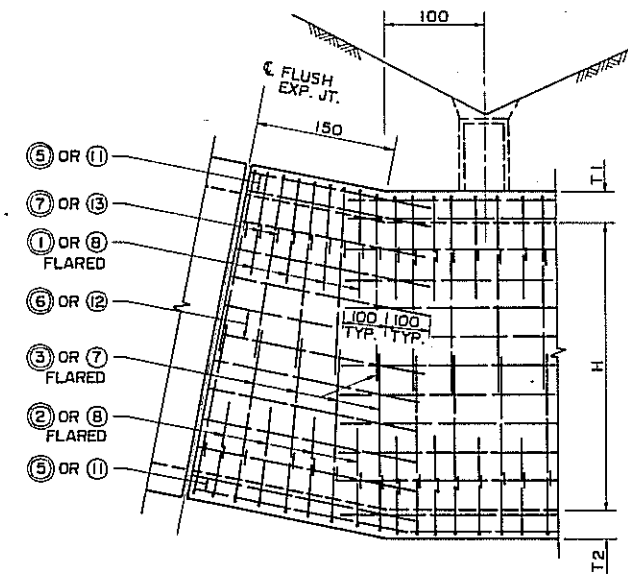
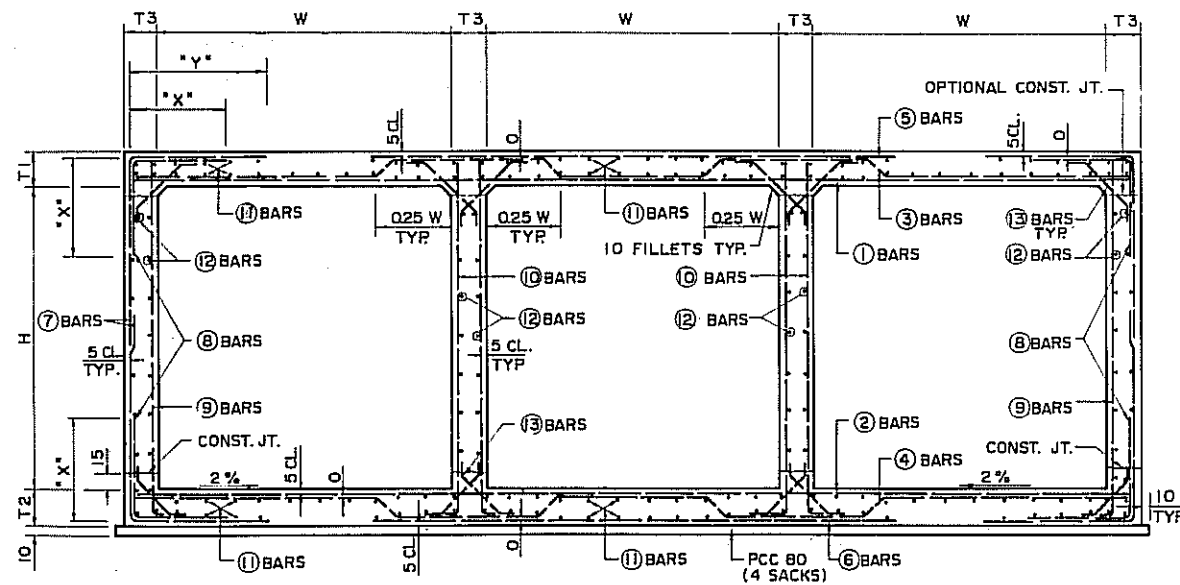

TYPICAL CROSS SECTION OF R.C. TRIPLE BOX CULVERT

VIEW B

CROSS SECTION

RC TRIPLE BOX CULVERT

CASE		TB1	TB2	TB3	TB4	TB5	TB6	TB7	TB8	TB9	TB10	TB11	TB12	TB13	TB14
W (SPAN)	M	2.5	2.5	3.0	3.0	3.0	3.0	3.5	3.5	3.5	3.5	4.0	4.0	5.0	3.5
H (HEIGHT)	M	2.0	2.0	2.0	2.0	2.0	2.0	2.5	3.0	3.0	3.0	3.0	3.0	3.0	2.5
MAX FILL OVER TOP	M	1.5	4.8	3.5	6.0	2.7	8.4	2.7	0.9	5.8	6.4	1.5	9.0	10.0	6.5
CONC. TOP SLAB	T1	CM	25	25	28	32	28	36	30	30	34	40	32	45	38
CONC. BOTTOM SLAB	T2	CM	25	25	28	34	28	38	30	30	36	40	35	45	40
CONC. SIDEWALL	T3	CM	25	25	28	30	28	34	27	27	32	35	30	40	36
REINFORCING STEEL BARS	(1) SIZE: BAR Ø	MM	16	16	16	16	16	19	16	19	16	19	19	19	19
	(1) SPACING	CM	28	28	28	30	32	26	34	32	32	34	36	26	22
	(2) SIZE: BAR Ø	MM	13	16	16	16	16	16	19	16	16	19	19	19	19
	(2) SPACING	CM	28	28	28	30	32	26	34	32	32	34	36	26	22
	(3) SIZE: BAR Ø	MM	16	19	19	22	19	22	19	25	25	22	29	29	25
	(3) SPACING	CM	28	28	28	30	32	26	34	32	32	34	36	26	22
	(4) SIZE: BAR Ø	MM	13	19	19	22	19	22	16	25	25	22	29	29	25
	(4) SPACING	CM	28	28	28	30	32	26	34	32	32	34	36	26	22
	(5) SIZE: BAR Ø	MM	16	19	19	22	19	22	19	25	25	22	29	29	25
	(5) SPACING	CM	28	28	28	30	32	26	34	32	32	34	36	26	22
	(6) SIZE: BAR Ø	MM	16	19	19	22	19	22	19	25	25	22	29	29	25
	(6) SPACING	CM	28	28	28	30	32	26	34	32	32	34	36	26	22
	(7) SIZE: BAR Ø	MM	13	13	13	13	16	16	19	16	19	19	19	19	19
	(7) SPACING	CM	28	28	28	30	32	26	34	32	32	34	36	26	22
(7) DIMENSION 'Y'	CM	105	105	120	120	130	130	130	130	130	130	140	140	180	
(8) SIZE: BAR Ø	MM	13	13	13	13	13	16	16	16	16	16	16	16	16	
(8) SPACING	CM	28	28	28	30	32	26	34	32	32	34	36	26	22	
(8) DIMENSION 'X'	CM	80	80	90	90	90	90	90	90	90	90	105	105	130	
(9) SIZE: BAR Ø	MM	13	13	13	13	13	13	13	13	13	13	13	13	13	
(9) SPACING	CM	28	28	28	30	32	26	34	32	32	34	36	26	22	
(10) SIZE: BAR Ø	MM	13	13	13	13	13	13	13	13	13	13	13	13	13	
(10) SPACING	CM	28	28	28	30	32	26	34	32	32	34	36	26	22	
(11) SIZE: BAR Ø	MM	13	13	13	13	13	13	13	13	13	13	13	13	13	
(11) SPACING	CM	25	25	25	25	25	30	30	30	30	35	25	30	30	
(12) SIZE: BAR Ø	MM	13	13	13	13	13	13	13	13	13	13	13	13	13	
(12) SPACING	CM	35	35	35	35	35	35	35	35	35	35	35	30	25	
(13) SIZE: BAR Ø	MM	13	13	13	13	13	13	13	13	13	13	13	13	13	
(13) SPACING	CM	28	28	28	30	32	26	34	32	32	34	36	26	22	
QUANTITIES CONCRETE (7 SACKS)	M ³ /M	6.28	6.28	7.94	9.16	9.06	11.78	9.68	10.22	12.12	13.75	12.47	17.07	25.58	12.94
QUANTITIES CONCRETE (4 SACKS)	M ³ /M	0.87	0.87	1.03	1.04	1.03	1.06	1.18	1.18	1.20	1.21	1.34	1.38	1.72	1.22
QUANTITIES REINFORCING STEEL BAR	KG/LM	536	769	721	802	755	1030	941	871	1115	1139	1017	1783	2663	1148

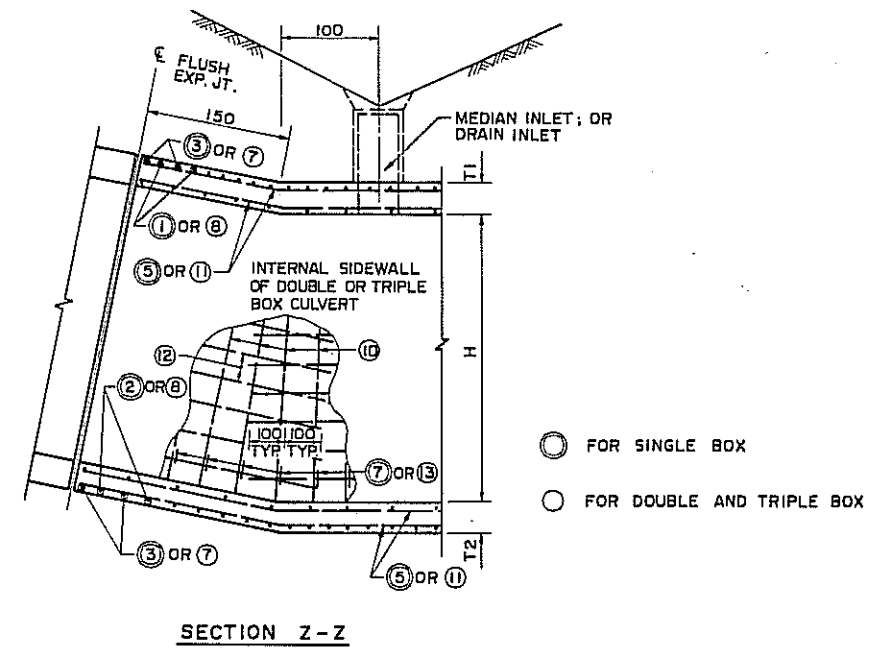

DETAIL OF BOX CULVERT AT SLOPE CHANGE

修正 REVISIONS	項目 ITEM	日期 DATE

交通部台灣區高速公路工程局
TAIWAN AREA FREEWAY CONSTRUCTION BUREAU
中華民國
南北高速公路 NORTH-SOUTH FREEWAY
苗栗台中段 MIAOLI-TAICHUNG SECTION

排水箱涵 (II) RC BOX CULVERT (II)

中華顧問工程司 CHINA ENGINEERING CONSULTANTS, INC.
日期 DATE AUG. '74 比例 SCALE N T S 圖號 SHEET DT-10

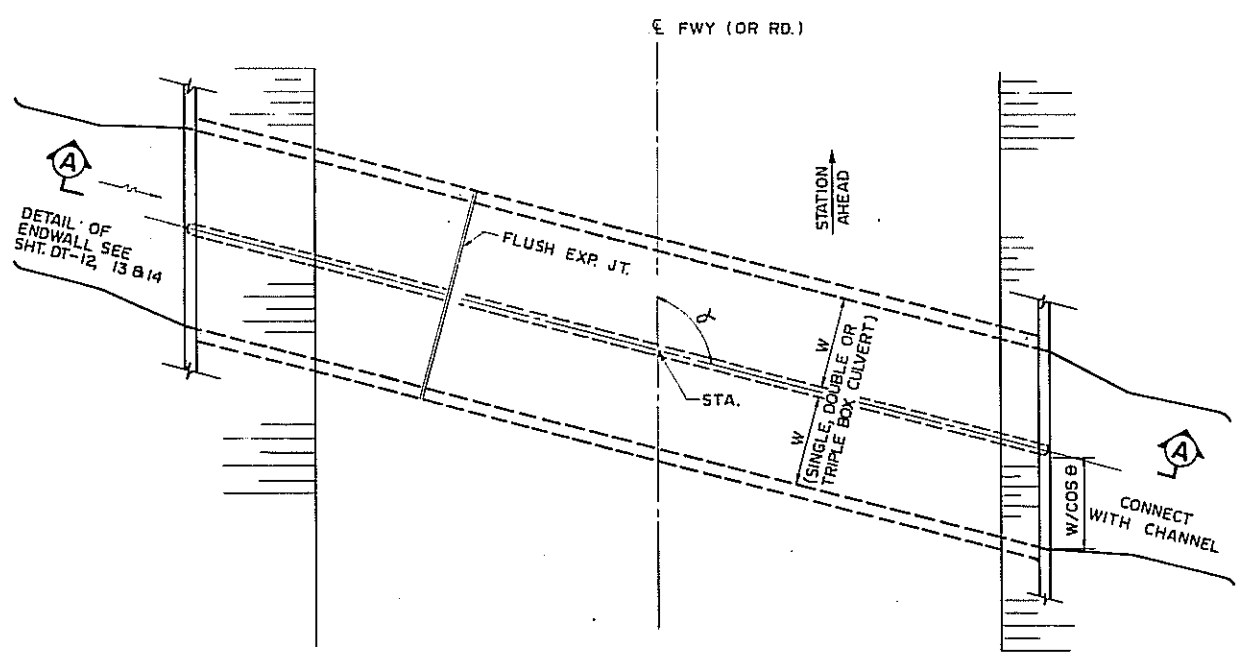

PLAN

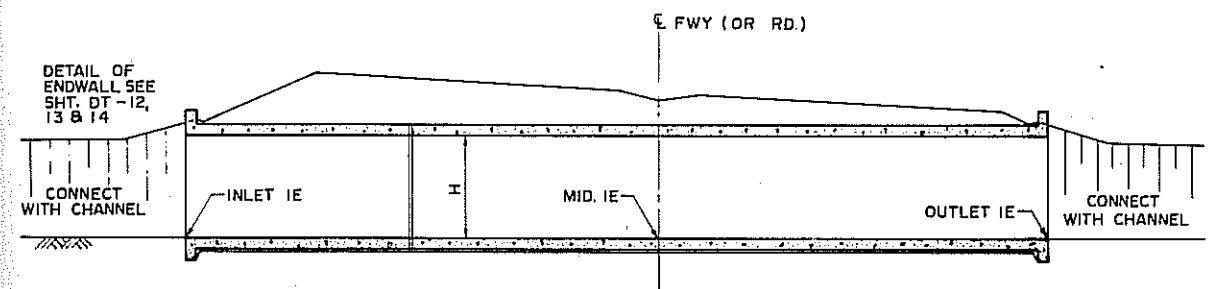

TYPICAL LONGITUDINAL SECTION A-A

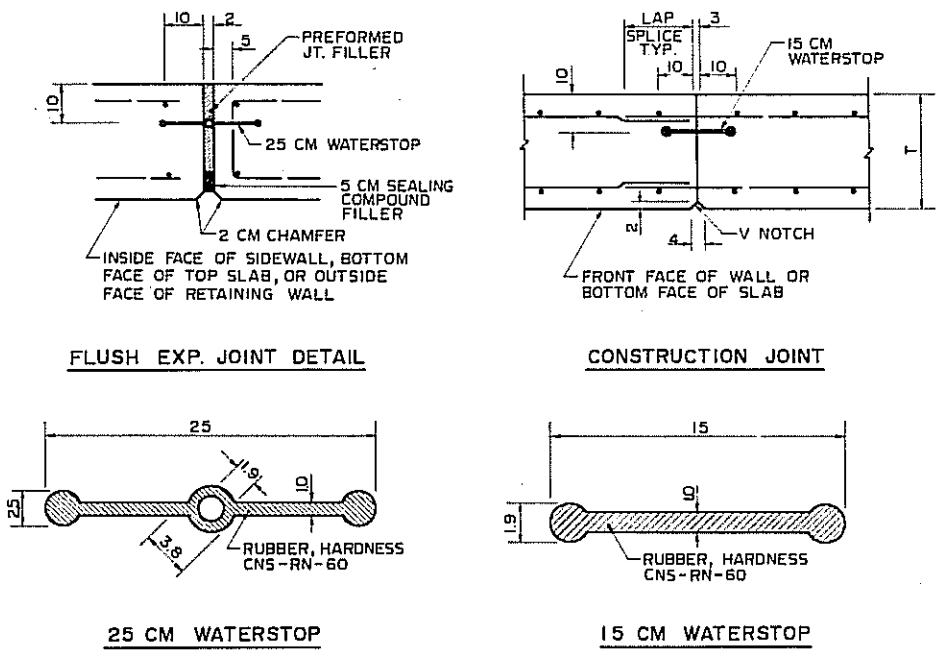

FLUSH EXP. JOINT DETAIL

CONSTRUCTION JOINT

25 CM WATERSTOP

15 CM WATERSTOP

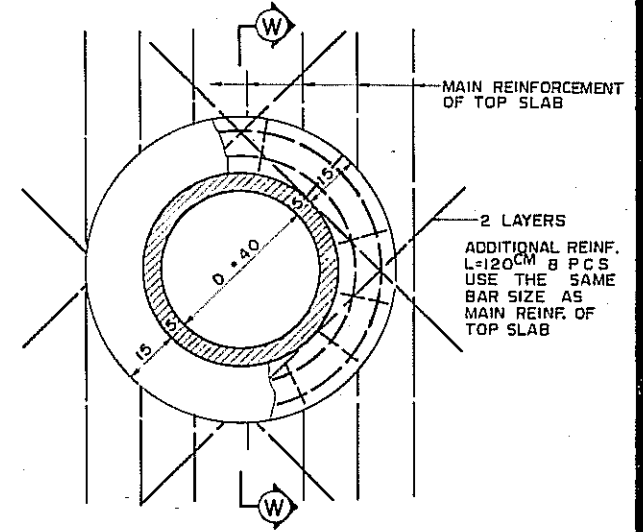

PLAN

SEE SHT. NO. DT-15, 19 & 27 FOR REFERENCE

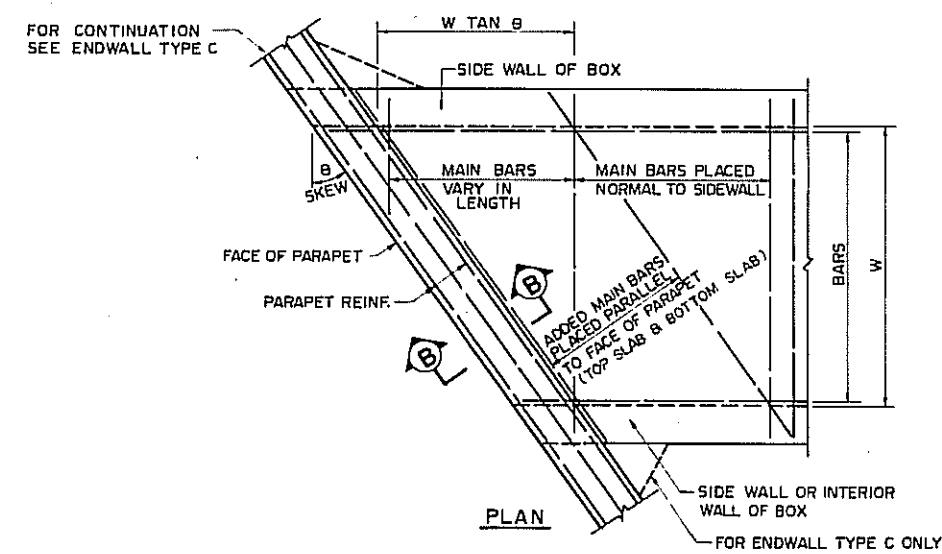

END OF BOX DETAIL (SKEW OVER 20°)

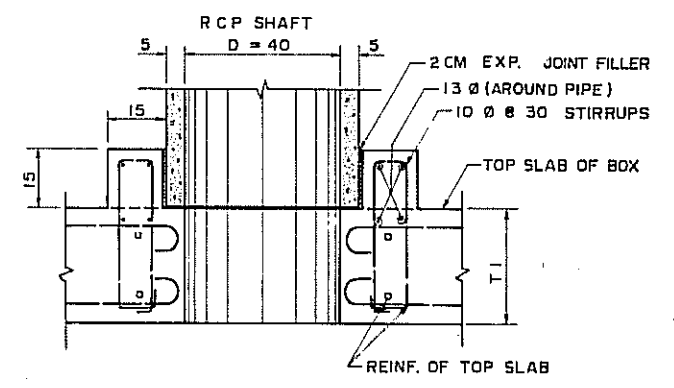

SECTION W-W BOX TOP SLAB WITH PIPE INLET

REINFORCEMENT OF SKEW PARAPET

W/COS θ (M)	< 3.5	3.5-4.5	4.5-5.5	5.5-8.0
(16) BARS	3-16Ø	3-19Ø	3-22Ø	3-25Ø
(17) "			4-16Ø	
(18) "			13 Ø @ 30	
(15) "			13 Ø @ 30	

* IF W=3.0M USE $z=40$ CM, OTHERWISE $z=30$ CM.

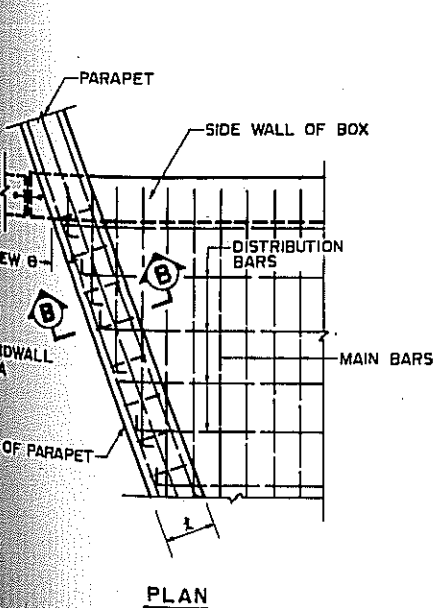

PLAN

SINGLE BOX

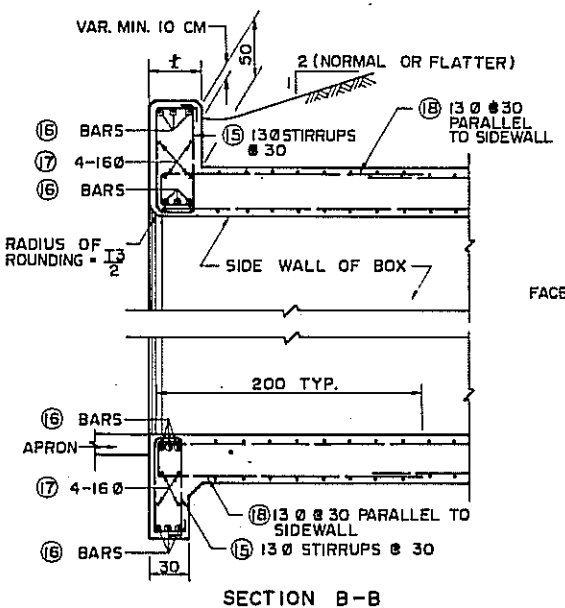

SECTION B-B

END OF BOX DETAILS (SKEW UP TO 20°)

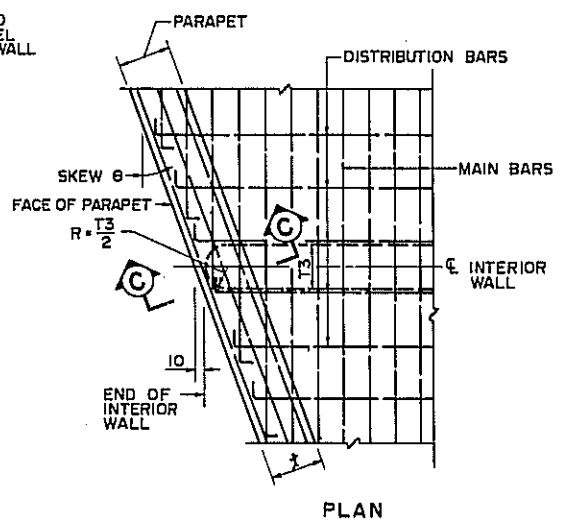

PLAN

DOUBLE OR TRIPLE BOX

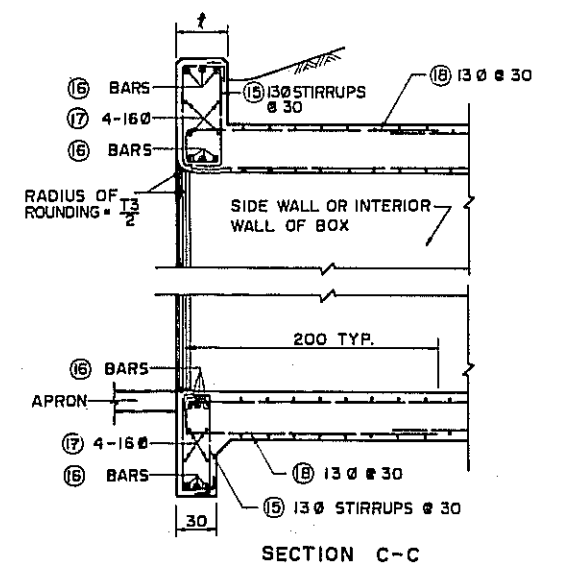

SECTION C-C

修正 REVISIONS	項目 ITEM	日期 DATE

交通部台灣區高速公路工程局
 TAIWAN AREA FREEWAY CONSTRUCTION BUREAU
 中華民國
 中華人民共和國
 南北高速公路 NORTH-SOUTH FREEWAY
 苗栗台中段 MIAOLI-TAICHUNG SECTION
 排水箱涵(III) RC BOX CULVERT (III)
 中華顧問工程司 CHINA ENGINEERING CONSULTANTS, INC.
 日期 DATE AUG. 74 比例 SCALE NTS 圖號 SHEET DT-11

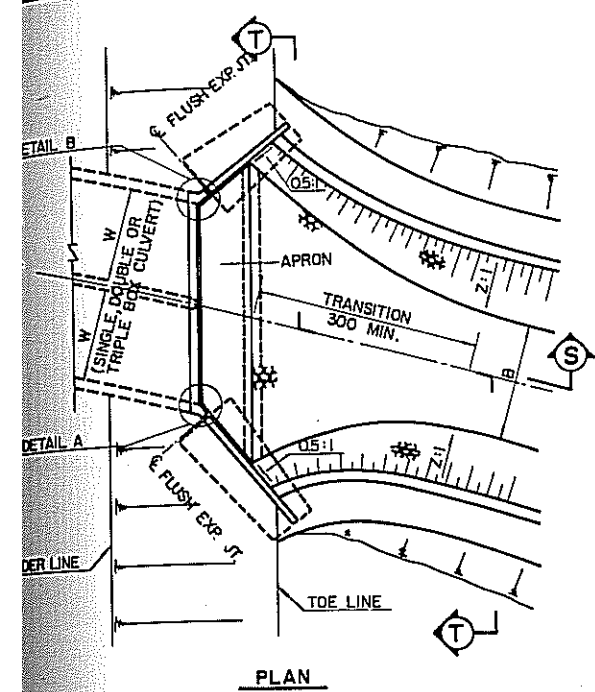

PLAN

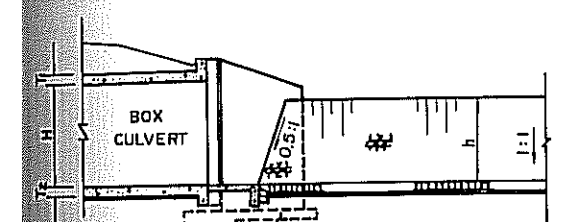

SECTION S-S

ENDWALL WITH TRANSITION

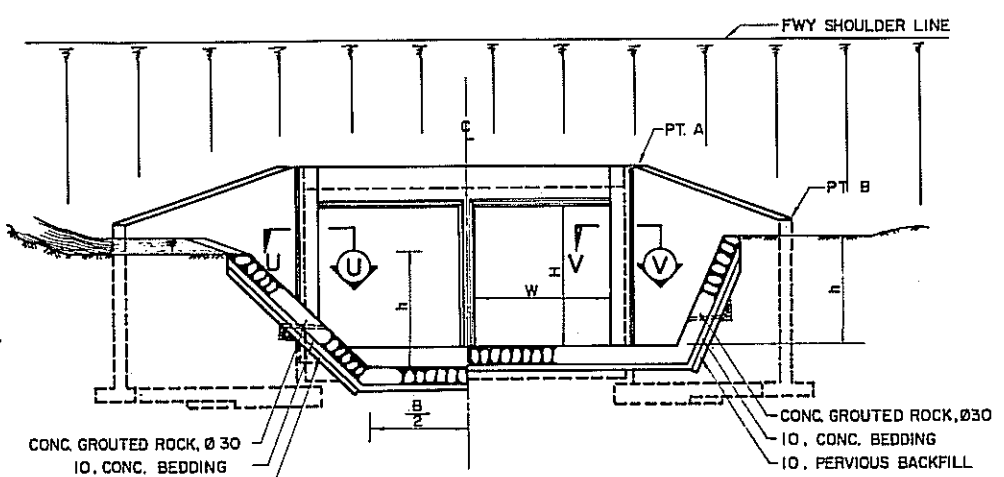

SECTION T-T

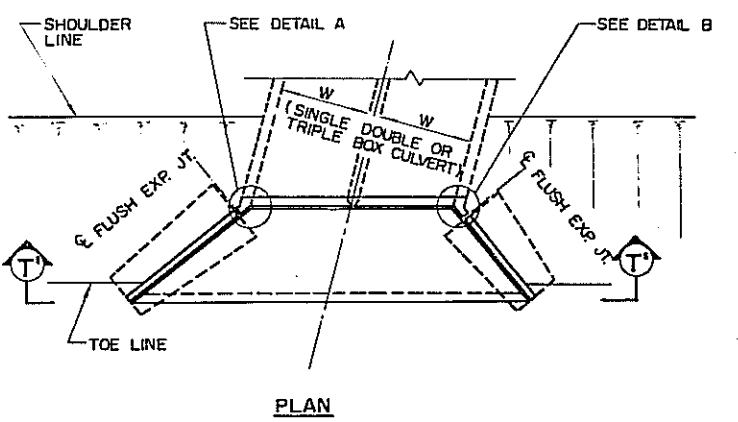

PLAN

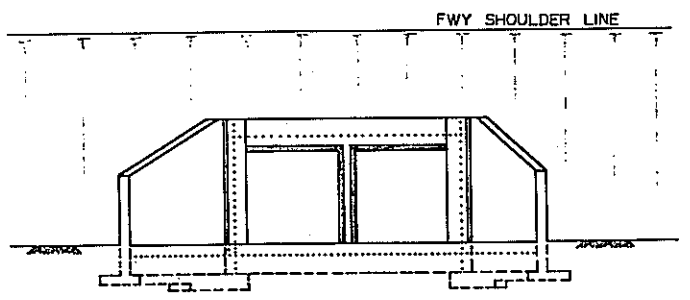

SECTION T-T

ENDWALL WITHOUT TRANSITION

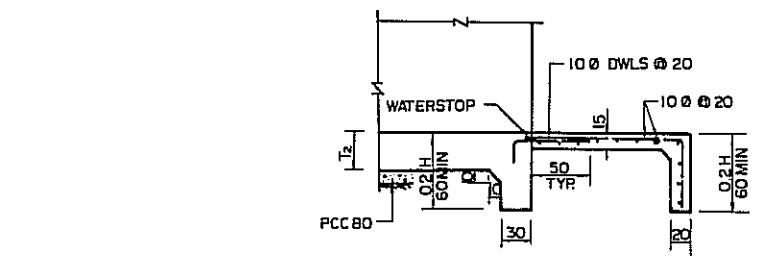

CONCRETE APRON

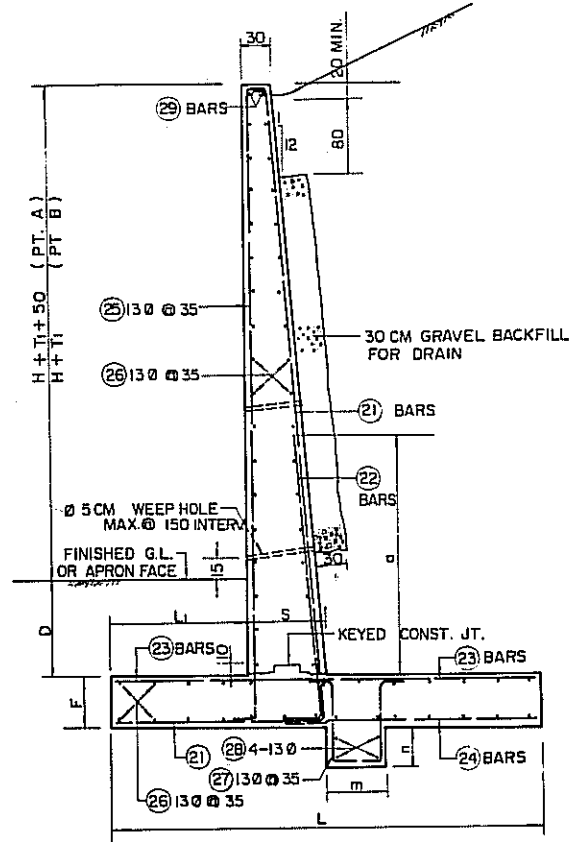

TYPICAL SECTION

箱涵 A 型端牆
RC BOX CULVERT ENDWALL, TYPE A

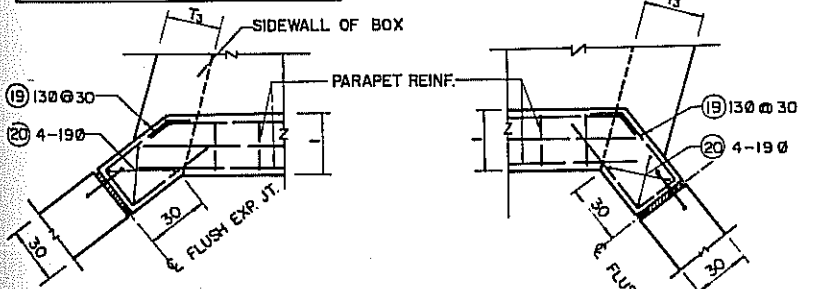

DETAIL A

DETAIL B

ENDWALL TYPE A REINFORCING STEEL BARS

CASE	EA1	EA2	EA3	EA4	EA5	EA6
(H)	150	200	250	300	350	400
D	60	60	60	60	70	80
F	40	40	40	40	45	45
L	190	228	266	304	342	380
L ₁	75	87	99	111	123	135
S	42.5	47	51.5	56	60.5	65
n	50	50	50	50	60	60
a	30	30	30	30	40	40
o	120	135	155	175	200	225
REINFORCING STEEL BARS	19	17#030	17#030	17#030	17#030	17#030
20	4-19#	4-19#	4-19#	4-19#	4-19#	4-19#
21	13#035	13#030	16#030	19#030	22#030	25#030
22	13#035	13#030	16#030	19#030	22#030	25#030
23	13#035	13#030	16#030	19#030	22#030	25#030
24	13#035	13#030	16#030	19#030	22#030	25#030
25	13#035	13#035	13#035	13#035	13#035	13#035
26	13#035	13#035	13#035	13#035	13#035	13#035
27	13#035	13#035	13#035	13#035	13#035	13#035
28	4-19#	4-19#	4-19#	4-19#	4-19#	4-19#
29	2-16#	2-16#	2-16#	2-16#	2-19#	2-19#

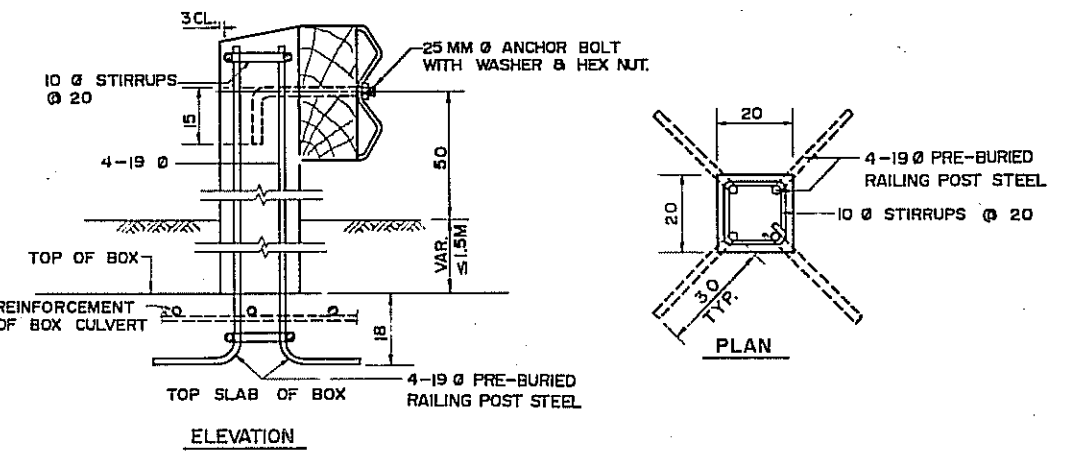

ELEVATION

PLAN

RAILING POST

SCALE 1:10

NOTE: THIS TYPE OF POST IS USED FOR BOXES WITH FILL ≤ 1.5M ONLY. FOR LOCATION SEE HIGHWAY PLANS.

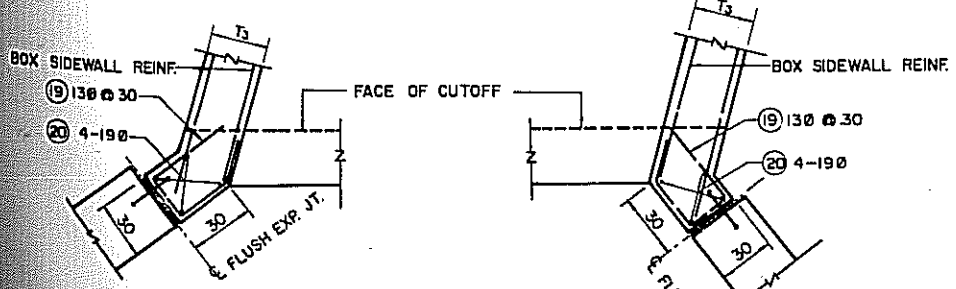

SECTION U-U

SECTION V-V

DRAINAGE STANDARD, DETAILS

修正	REVISIONS	項目	ITEM	日期	DATE

交通部台灣區高速公路工程局
TAWAN AREA FREEWAY CONSTRUCTION BUREAU
中華民國
Republic of China
南北高速公路
苗栗-台中段
NORTH-SOUTH FREEWAY
MIAOLI-TAICHUNG SECTION
排水箱涵 (IV) RC BOX CULVERT (IV)
中華顧問工程司
CHINA ENGINEERING CONSULTANTS, INC.
日期 DATE AUG. '74 比例 SCALE N T S 圖號 SHEET DT-12

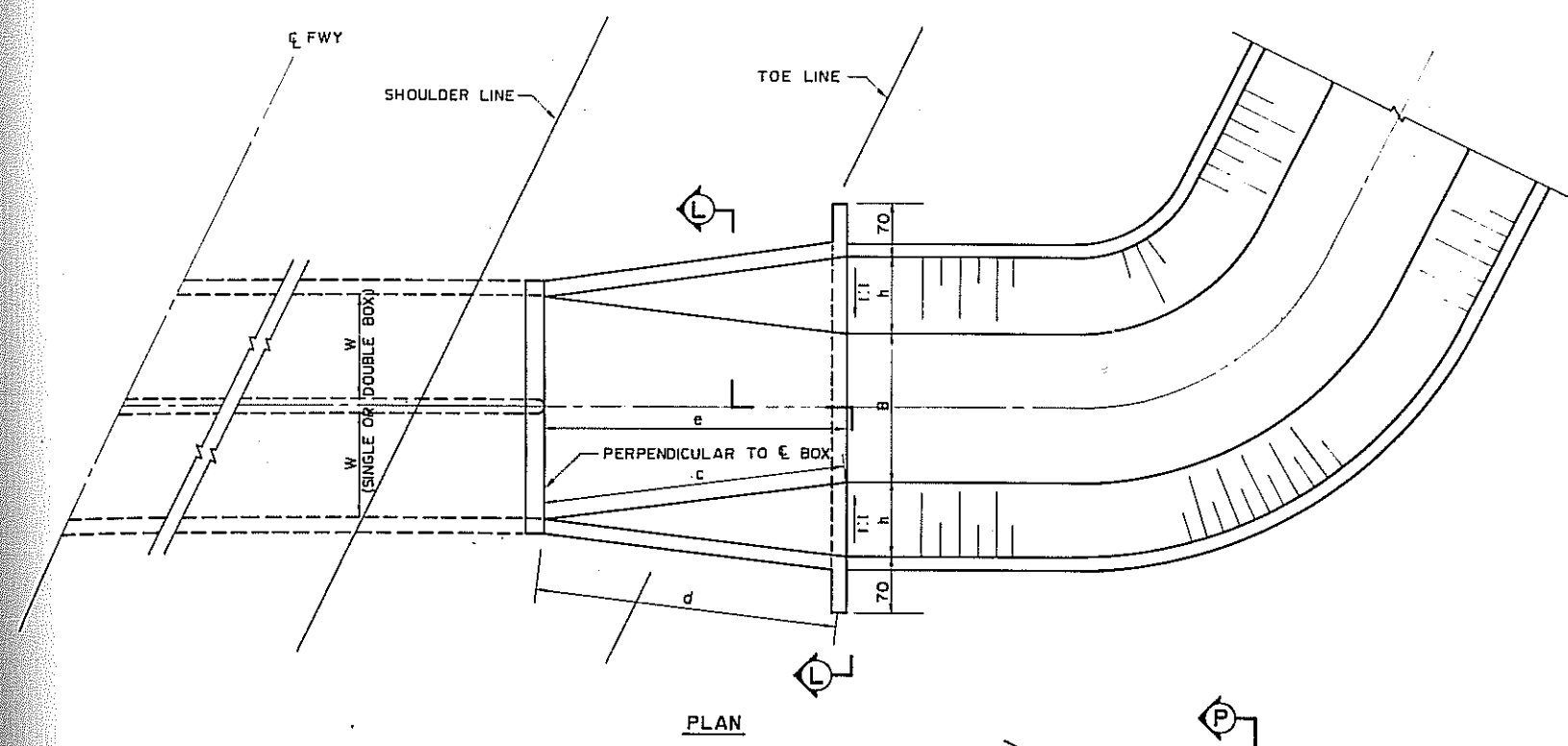

ENDWALL TYPE B REINFORCING STEEL BARS

TYPE	EB1	EB2	EB3	EB4	EB5	EB6
H	1.5	2.0	2.5	3.0	3.5	4.0
Y	1.5	2.0	2.5	3.0	3.5	4.0
C	3.31	3.40	3.49	3.58	3.66	3.75
d	3.63	3.94	4.29	4.67	5.07	5.48
e	3.26	3.35	3.43	3.52	3.61	3.69
t ₁	20	20	25	25	30	30
L ₂	60	60	60	70	80	80
L ₅	60	80	100	120	140	160
REINFORCING STEEL	① 16#030	16#030	13#030	13#025	13#030	13#025
	② 16#022	16#022	16#030	16#025	16#030	16#025
	③		13#030	13#025	16#030	16#025
	④ 13#025	13#025	13#030	13#030	13#028	13#025
	⑤ 16#025	16#025	13#024	16#030	13#028	16#030
	⑥		13#030	13#030	13#025	16#030
	⑦ 2-16#	2-16#	2-13#	2-16#	2-13#	2-16#
	⑧ 2-16#	2-16#	2-19#	2-19#	2-19#	2-19#
	⑨ 2-19#	2-19#	2-19#	2-19#	2-19#	2-19#
	⑩ 4-13#	4-13#	4-13#	4-13#	4-16#	4-16#
	⑪ 2-19#	2-19#	2-22#	2-22#	2-25#	2-29#
	⑫ 13#030	13#030	13#030	13#030	13#030	13#030
	⑬ 13#030	13#030	13#030	13#030	13#030	13#030
	⑭		13#030	13#030	13#030	13#030

* NOTE: PLACE REINF. STEEL BARS AT CENTER OF SIDE WALL IF ONLY ONE ROW BARS ARE USED.

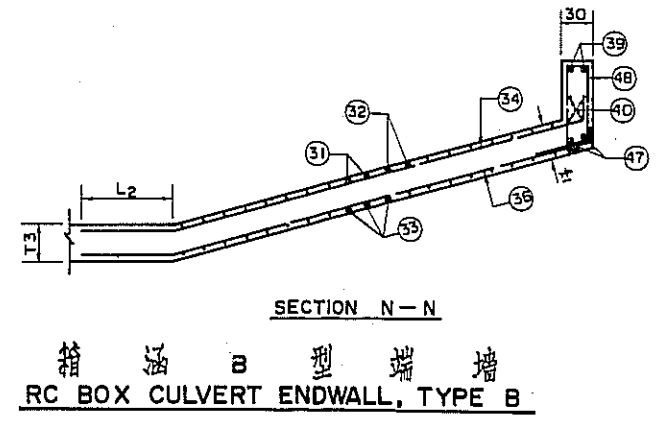
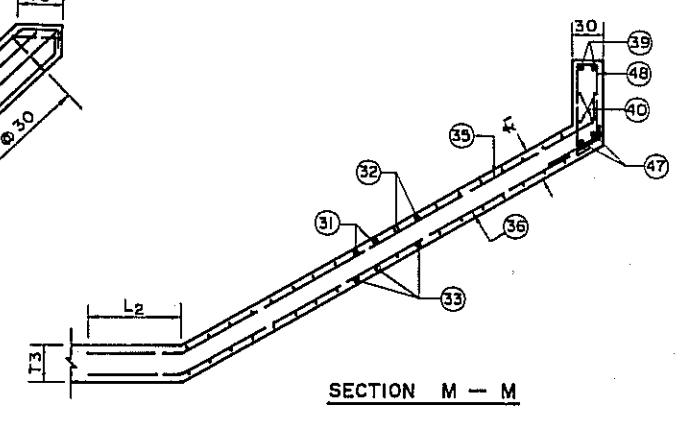
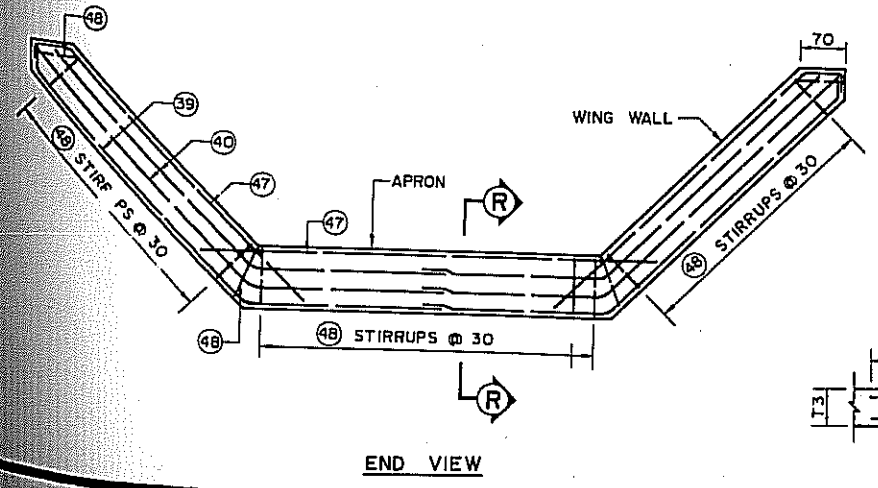
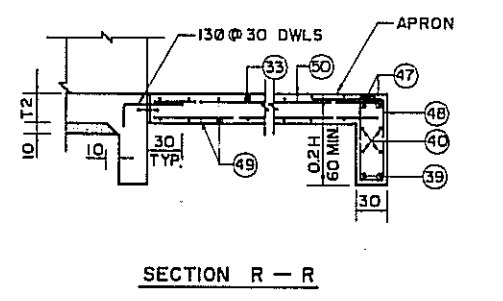
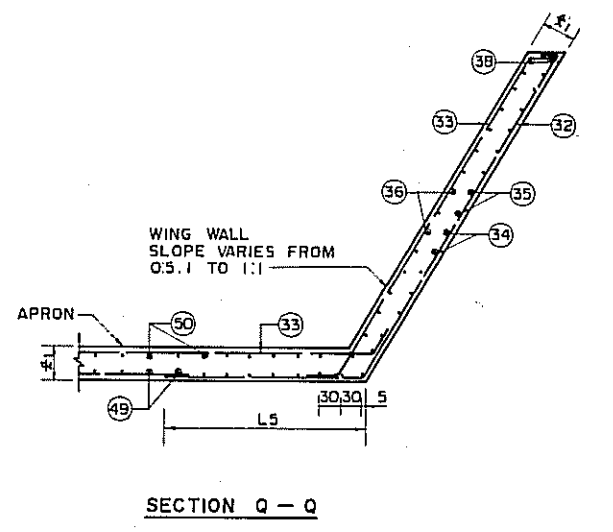
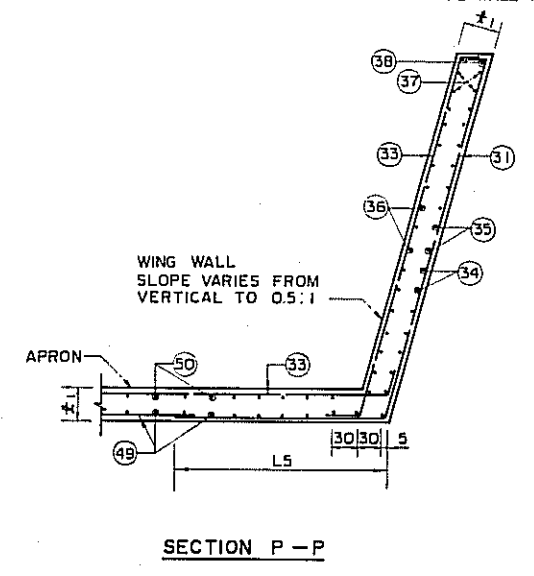
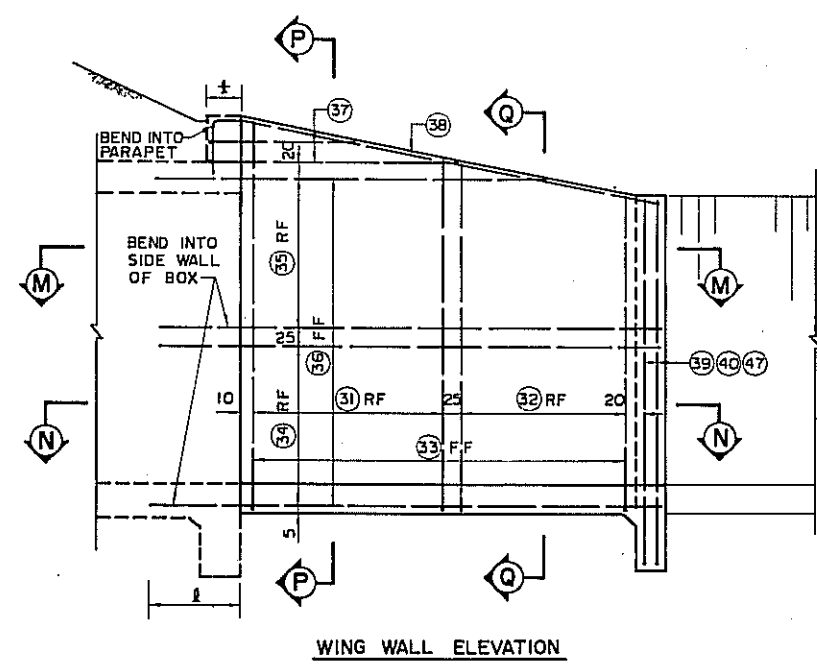
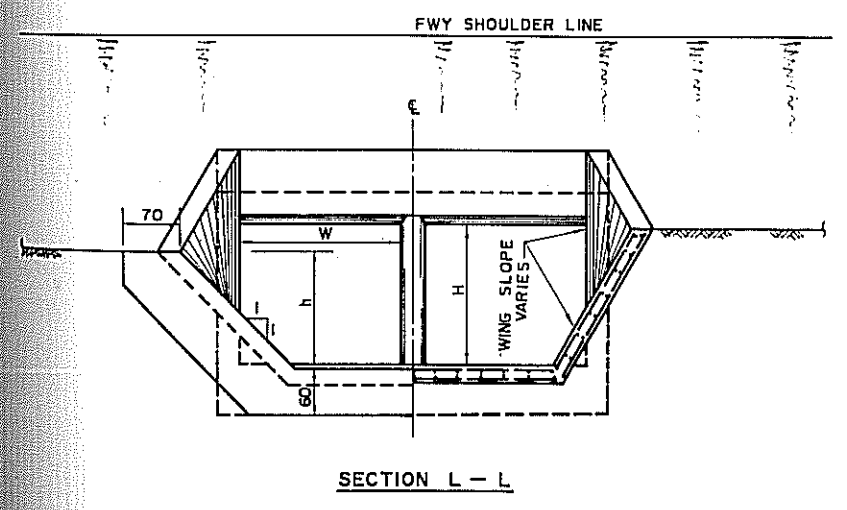

**箱涵B型端墙
RC BOX CULVERT ENDWALL, TYPE B**

DRAINAGE STANDARD DETAILS

修正 REVISIONS	項目 ITEM	日期 DATE

交通部台灣區高速公路工程局
TAIWAN AREA FREEWAY CONSTRUCTION BUREAU
中華民國
南北高速公路 **NORTH-SOUTH FREEWAY**
苗栗台中段 **MIAOLI-TAICHUNG SECTION**

排水箱涵(Ⅴ) RC BOX CULVERT (Ⅴ)

中華顧問工程司 **CHINA ENGINEERING CONSULTANTS, INC.**
日期 DATE AUG. '74 比例 SCALE NTS 圖號 SHEET DT-13

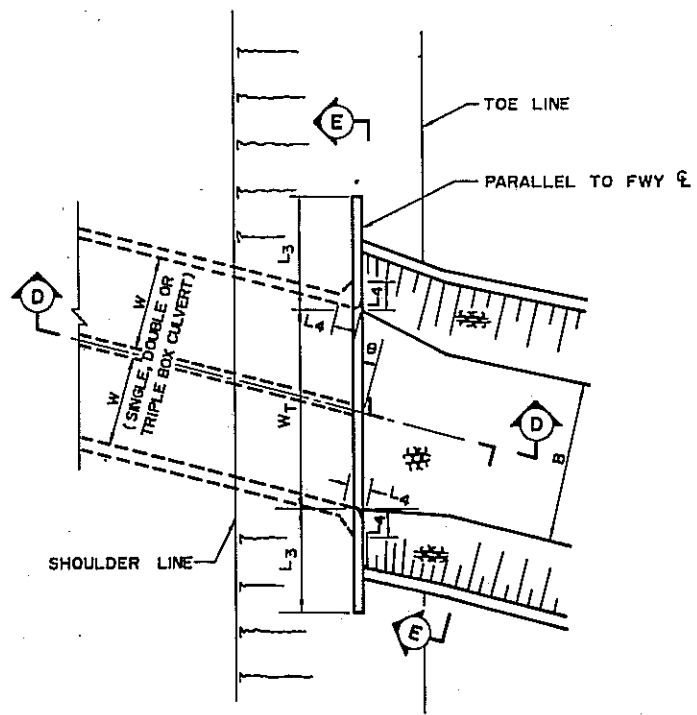

PLAN

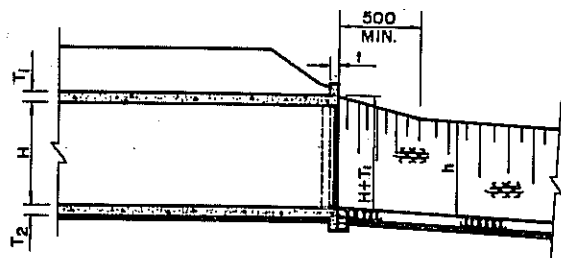

SECTION D-D

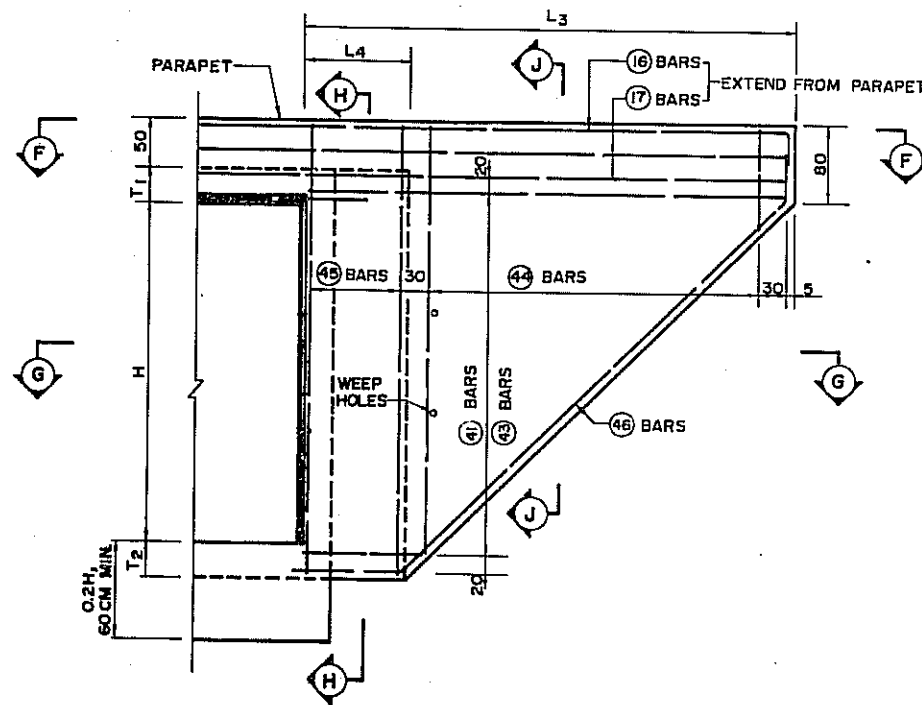

ELEVATION

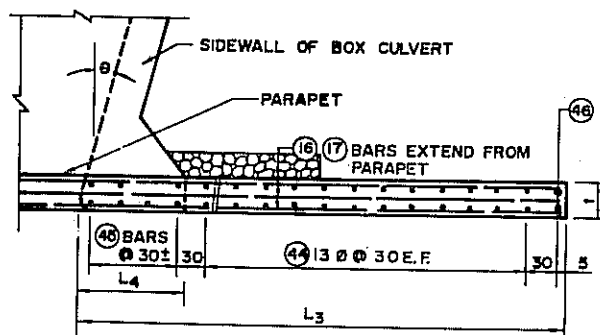

SECTION F-F

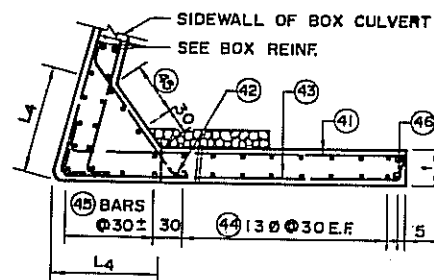

SECTION G-G

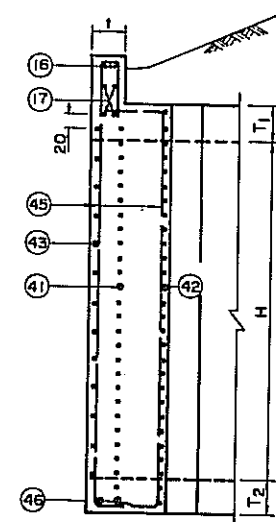

SECTION H-H

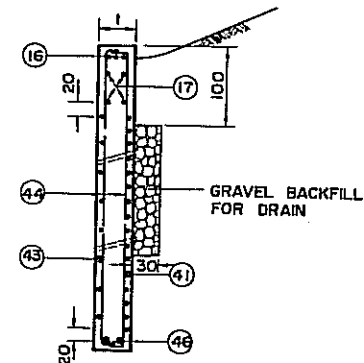

SECTION J-J

ENDWALL TYPE C REINFORCING STEEL BARS

TYPE		B01	B02	B03	B04	B05	B06
K	M	1.5	2.0	2.5	3.0	3.5	4.0
L3	M	2.1	2.7	3.1	4.3	4.8	5.3
L4	M	0.6	0.7	0.8	0.9	0.9	1.0
s	CM	30	30	30	40	40	40
n		0.7	0.7	0.7	1	1	1
REINFORCING STEEL	41	16#036	16#036	13#010	15#018	19#016	19#015
	42	16#036	16#036	13#010	16#018	19#016	19#015
	43	13#036	13#036	13#036	13#036	13#032	13#030
	44	13#030	13#030	13#030	13#030	13#030	13#030
	45	13#030	13#030	13#030	16#030	17#030	18#030
	46	2-16#	2-16#	2-19#	2-19#	2-22#	2-22#

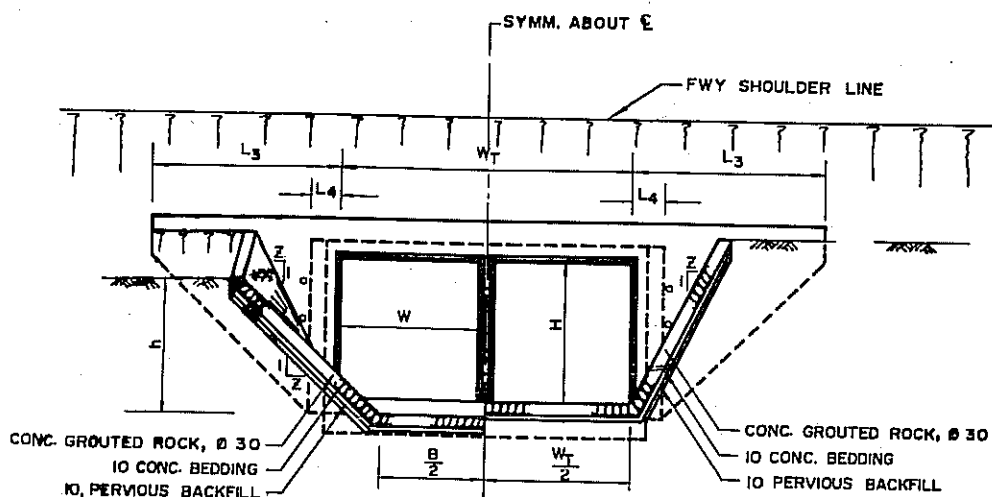

SECTION E-E

箱涵 C 型端墙
RC BOX CULVERT ENDWALL, TYPE C

DRAINAGE STANDARD DETAILS

修正	REVISIONS	項目	ITEM	日期	DATE

交通部台灣區高速公路工程局
TAIWAN AREA FREEWAY CONSTRUCTION BUREAU
中華民國
REPUBLIC OF CHINA
南北高速公路 NORTH-SOUTH FREEWAY
苗栗台中段 MIAOLI-TAICHUNG SECTION
排水箱涵 (VI) RC BOX CULVERT (VI)
中華顧問工程司 CHINA ENGINEERING CONSULTANTS, INC.
日期 DATE AUG. '74 比例 SCALE NTS 圖號 SHEET DT-14

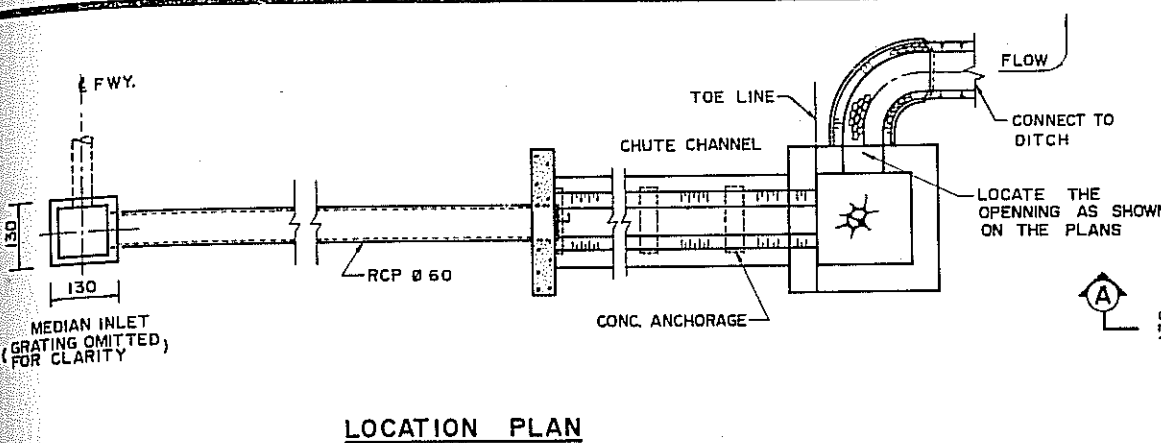

LOCATION PLAN

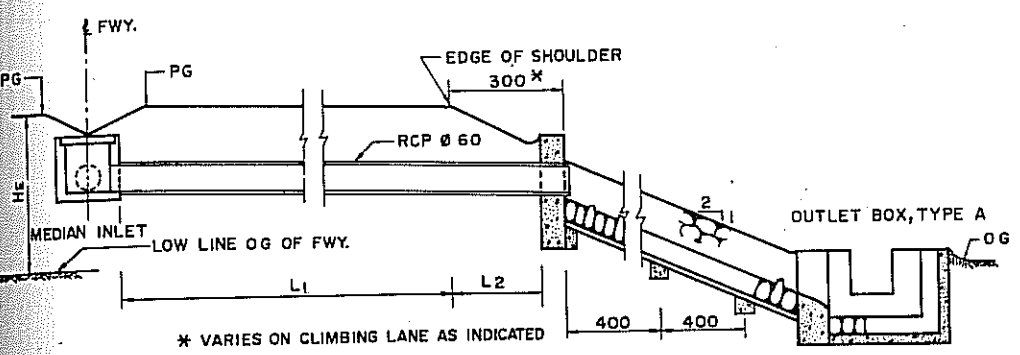

**CASE I, H_E > 3M
PROFILE**

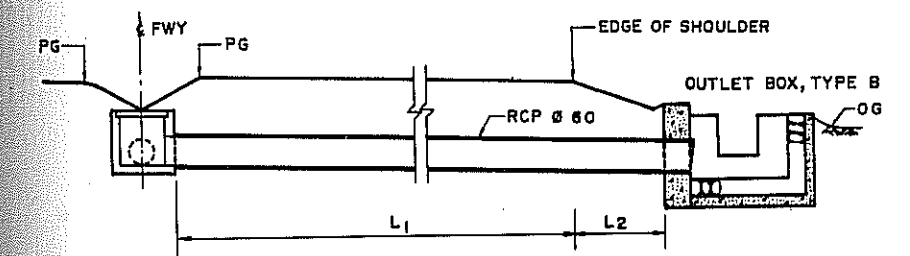

**CASE II, H_E ≤ 3M
PROFILE**

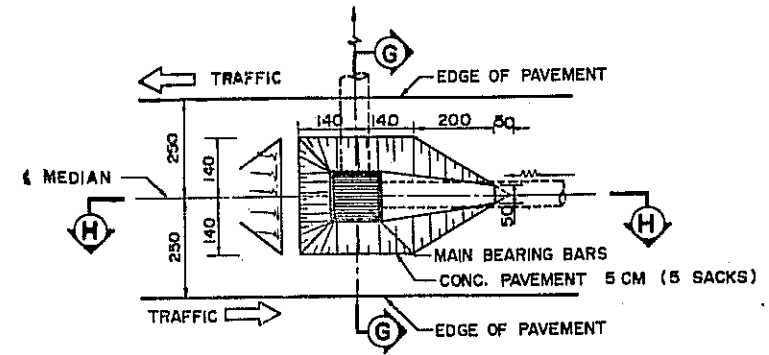

**LOCATION OF MEDIAN INLET
IN RELATION TO FFWY.**

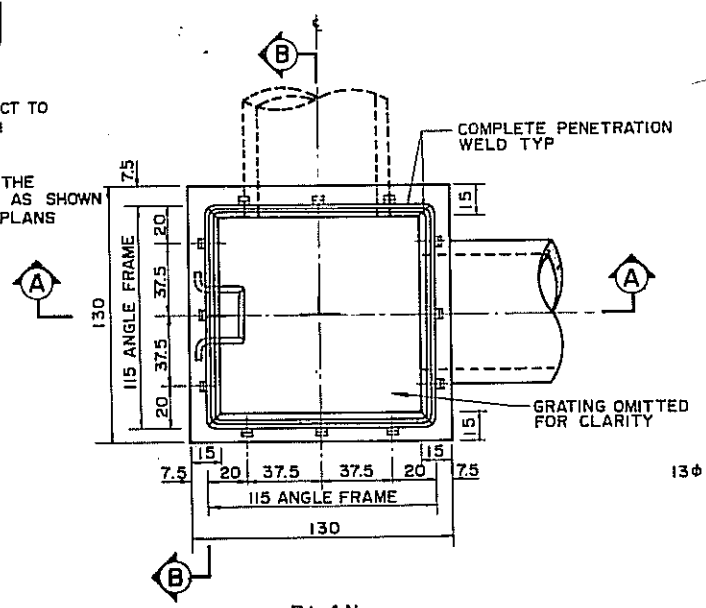

**PLAN
MEDIAN INLET**

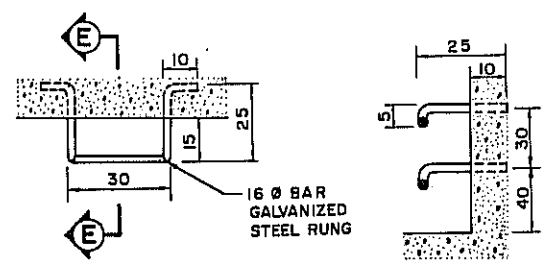

STEEL RUNG

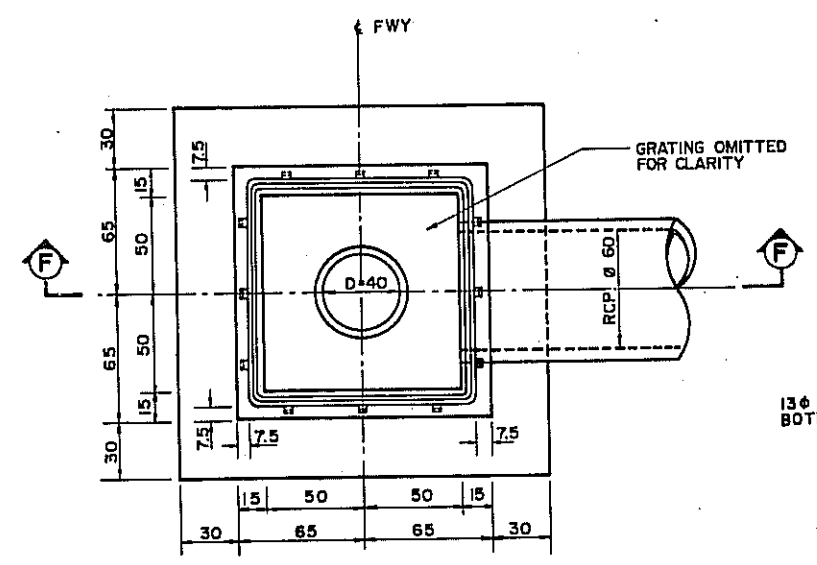

MEDIAN INLET WITH PIPE SHAFT

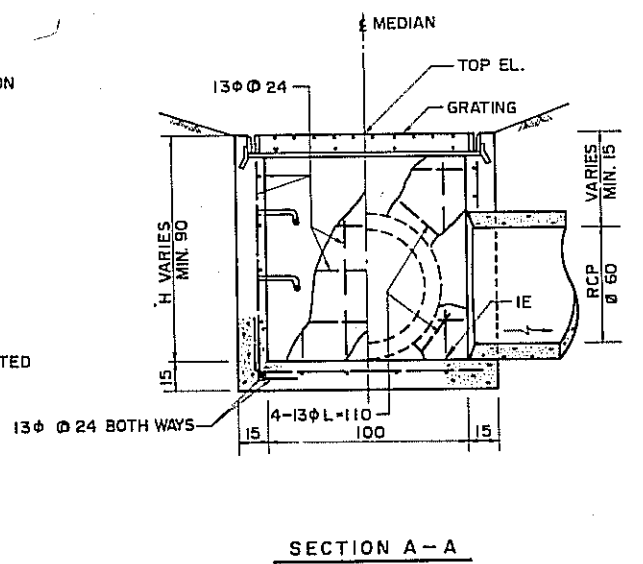

SECTION A-A

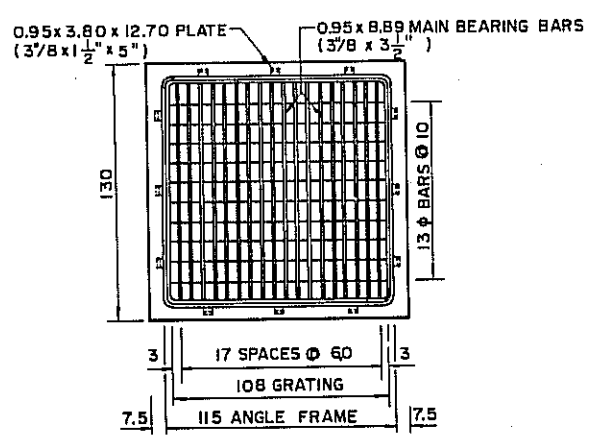

GRATING

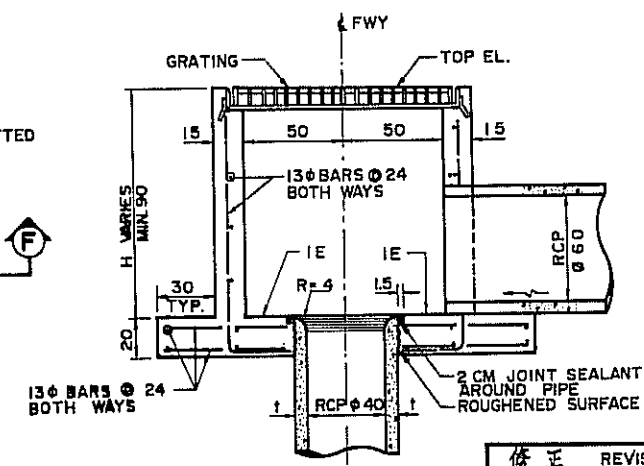

SECTION F-F

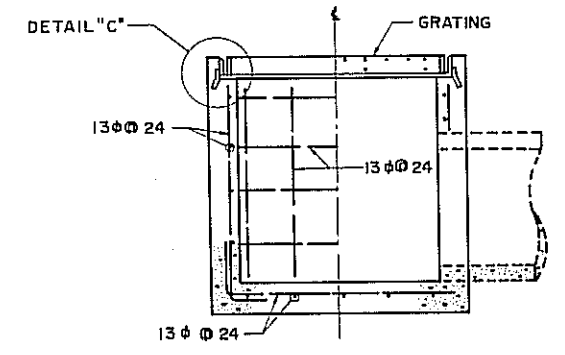

SECTION B-B

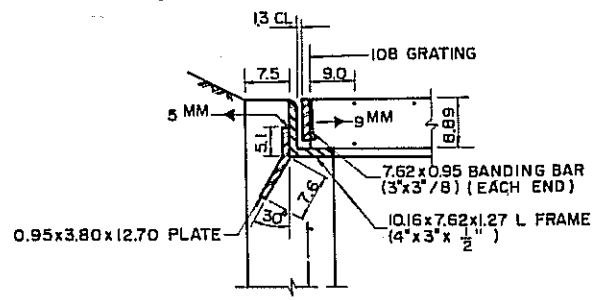

DETAIL "C"

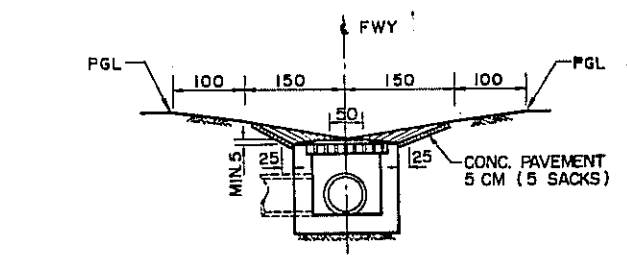

SECTION G-G

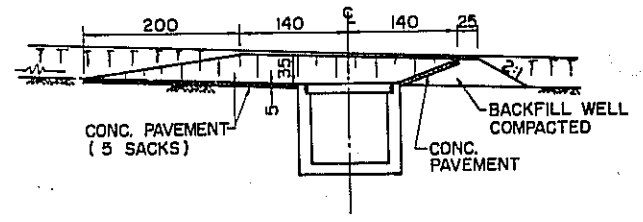

SECTION H-H

DRAINAGE STANDARD DETAILS

修正	REVISIONS	項目	ITEM	日期	DATE

交通部台灣區高速公路工程局
TAIWAN AREA FREEWAY CONSTRUCTION BUREAU
 中華民國
 南北高速公路 NORTH-SOUTH FREEWAY
 苗栗台中段 MIAOLI-TAICHUNG SECTION
 分隔帶進水井及排水口 (I) MEDIAN INLET & OUTLET (I)
 中華顧問工程司 CHINA ENGINEERING CONSULTANTS, INC.
 日期 DATE AUG. '74 比例 SCALE NTS 圖號 SHEET DT-15

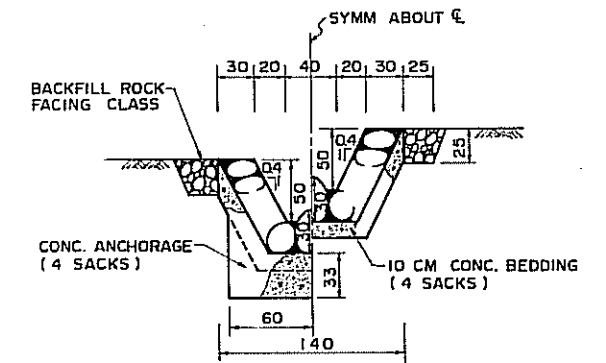
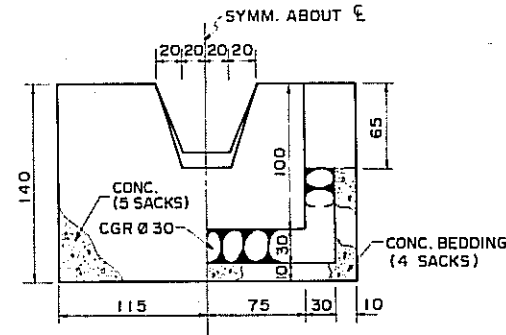
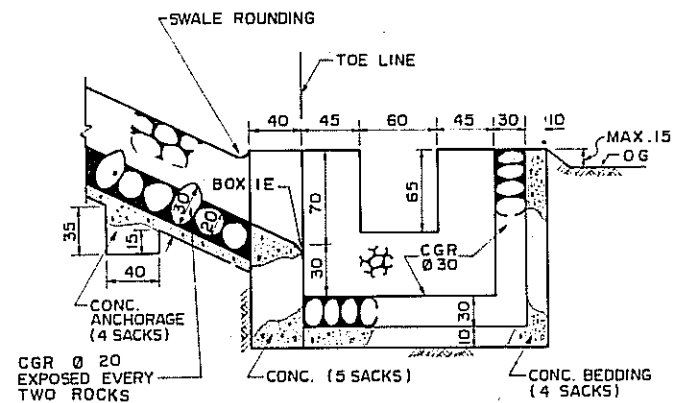
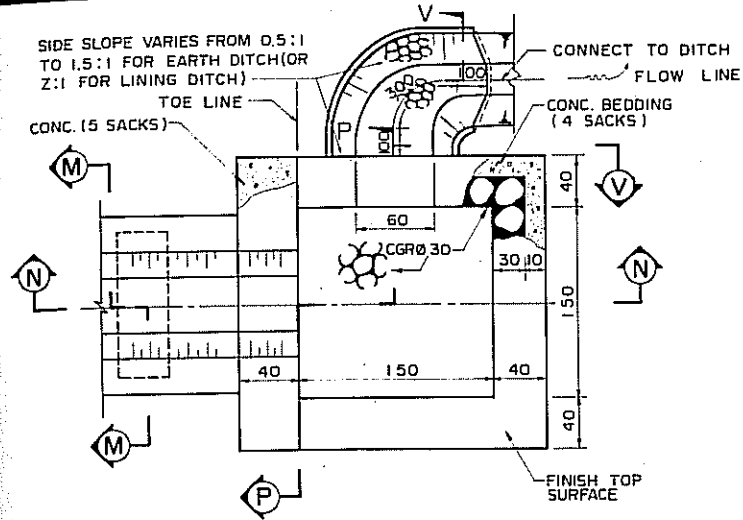

OUTLET BOX, TYPE A

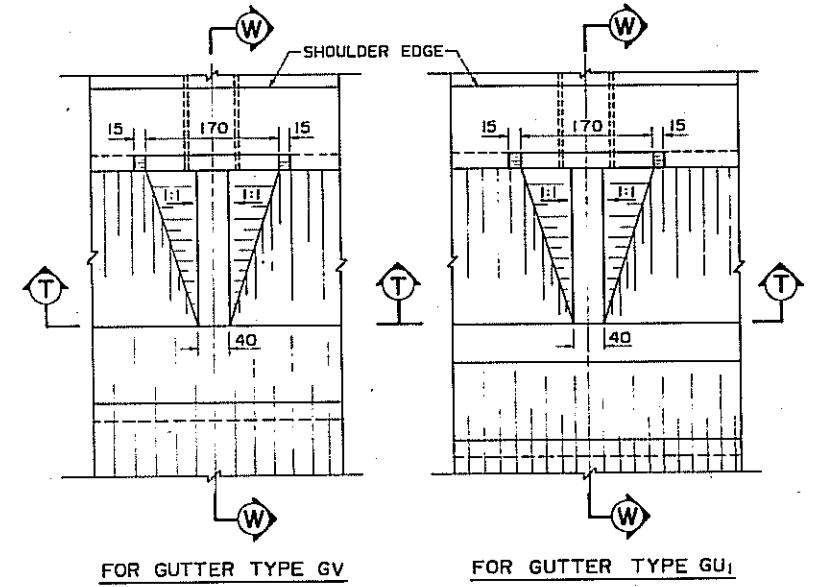
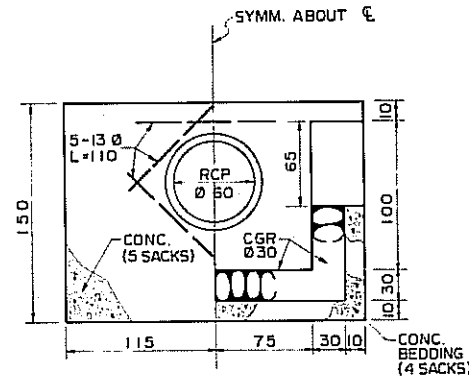
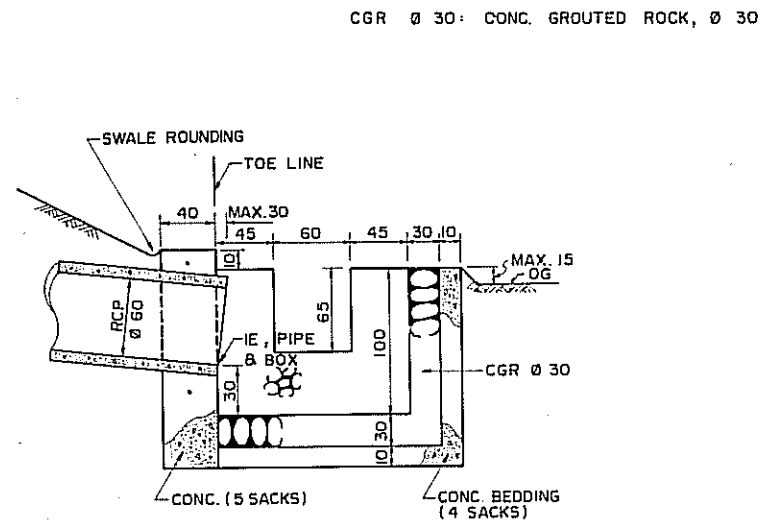
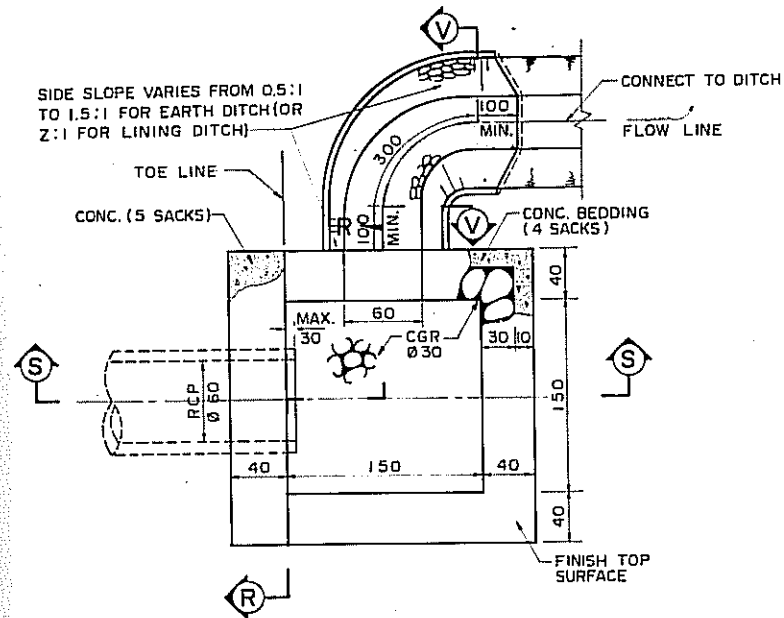

OUTLET BOX, TYPE B

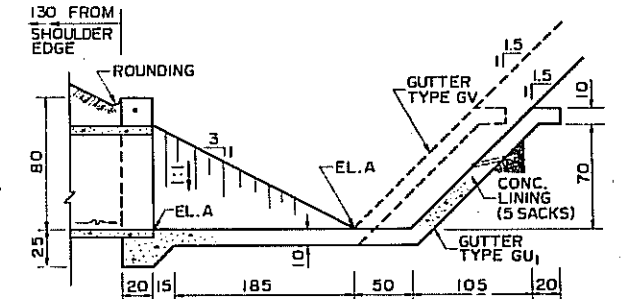
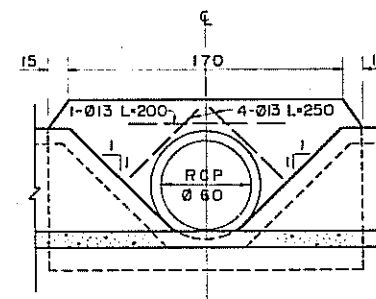
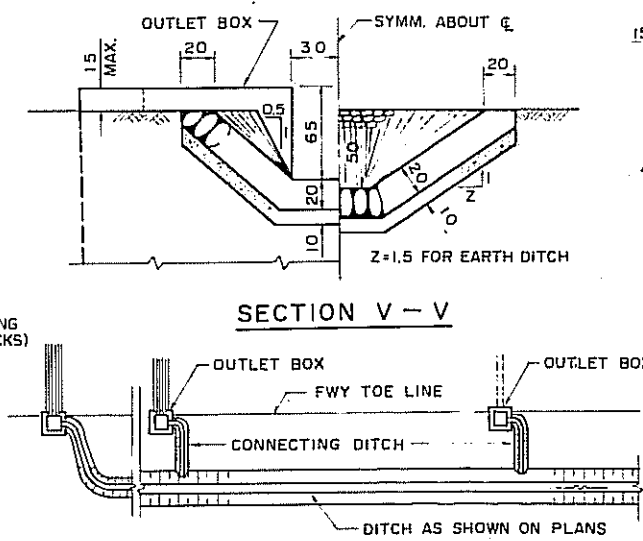
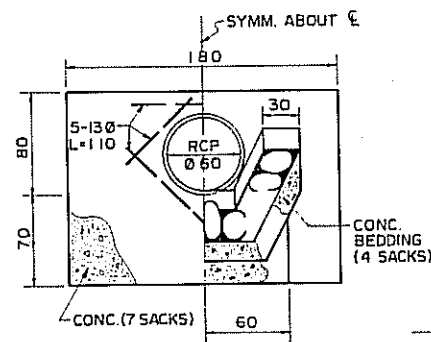
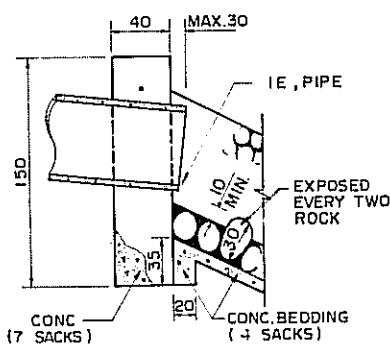
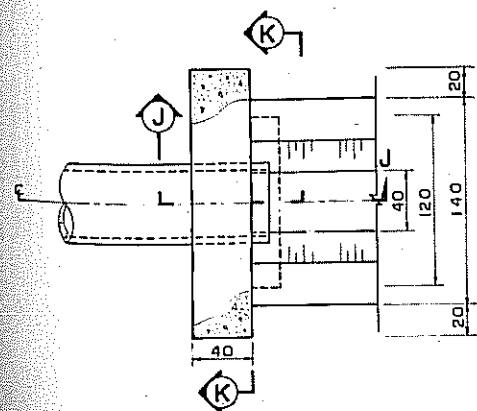

PLAN

SECTION J-J

SECTION K-K

SECTION V-V

SECTION T-T

SECTION W-W

LAYOUT FOR OUTLET BOX AND DITCHES

ENDWALL

REVISIONS		DATE	
NO.	DESCRIPTION	DATE	BY

交通部台灣區高速公路工程局
TAIWAN AREA FREEWAY CONSTRUCTION BUREAU
中華民國
REPUBLIC OF CHINA
南北高速公路 NORTH-SOUTH FREEWAY
苗栗台中段 MIAOLT-TAICHUNG SECTION
分隔帶進水井及排水口 (II) MEDIAN INLET & OUTLET (II)
中華顧問工程司 CHINA ENGINEERING CONSULTANTS, INC.
日期 DATE AUG. 74 比例 SCALE NTS 圖號 SHEET DT-16

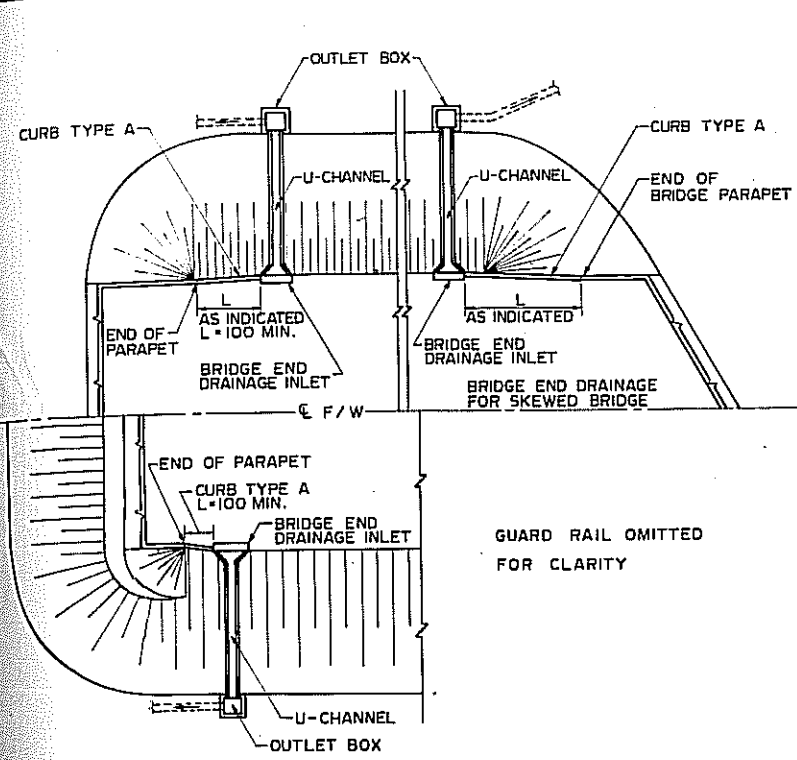

LOCATION

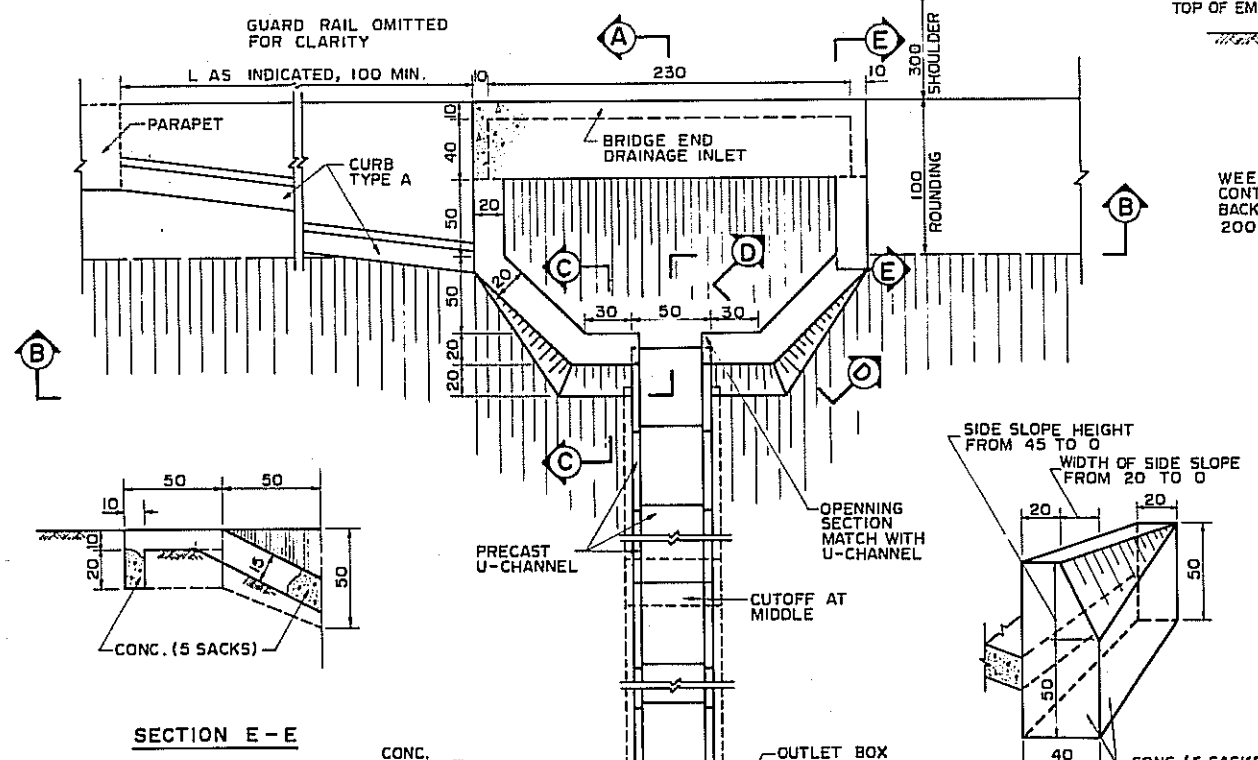

SECTION E-E

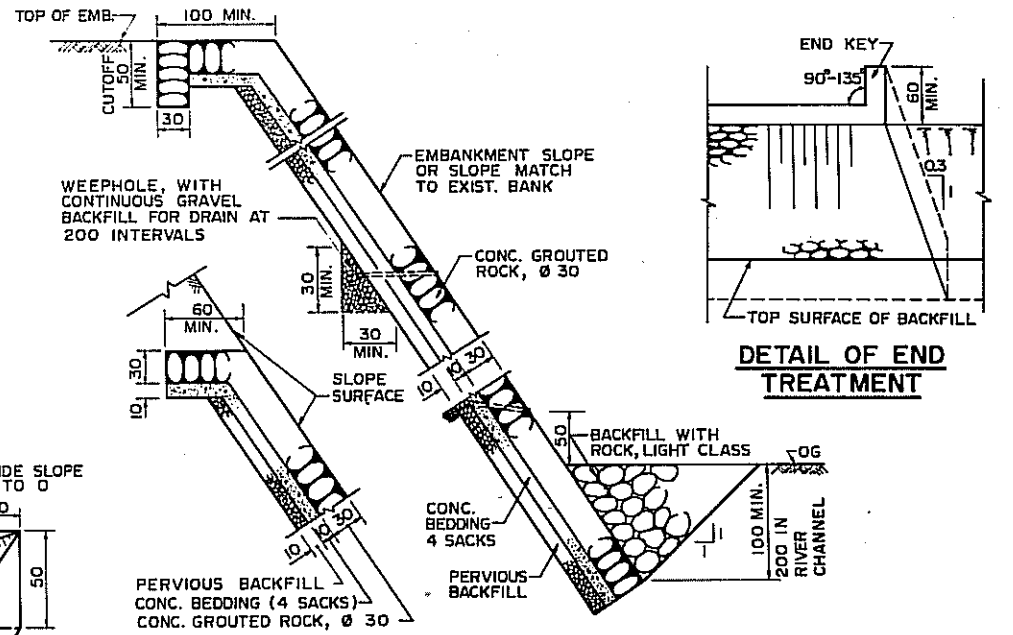

路堤護坡標準斷面
TYPICAL SECTIONS
FOR EMBANKMENT SLOPE PROTECTION

FOR EMBANKMENT SLOPE PROTECTION

ESTIMATED QUANTITIES OF STRUCTURES

ITEM	UNIT	ESTIMATED QUANTITIES			
		CONCRETE (M ³) 4 SACKS	CONC. GROUTED ROCK, Ø 30 (M ²) 5 SACKS	PRECAST U-CHANNEL (EA)	PERVIOUS BACKFILL (M ³)
BRIDGE END DRAINAGE INLET	EA.		1.13		
BRIDGE END DRAINAGE OUTLET BOX	EA.	1.17	1.19	8.49	
OUTLET CHANNEL	LM	0.107		2.236	
EMBANKMENT SLOPE PROTECTION	M ²	0.10		1.00	0.10

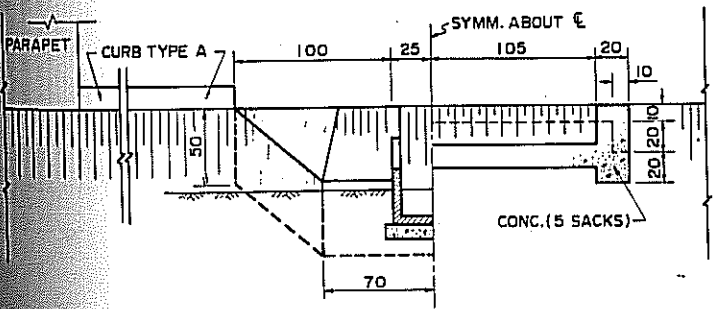

SECTION B-B

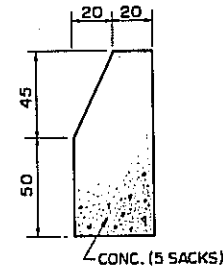

SECTION C-C

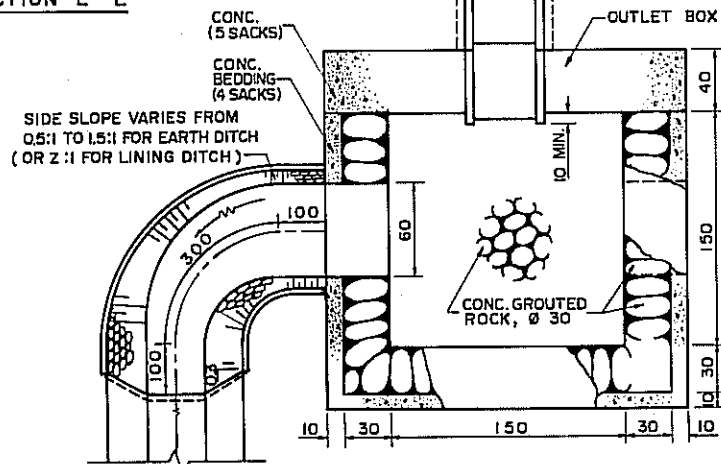

SECTION D-D

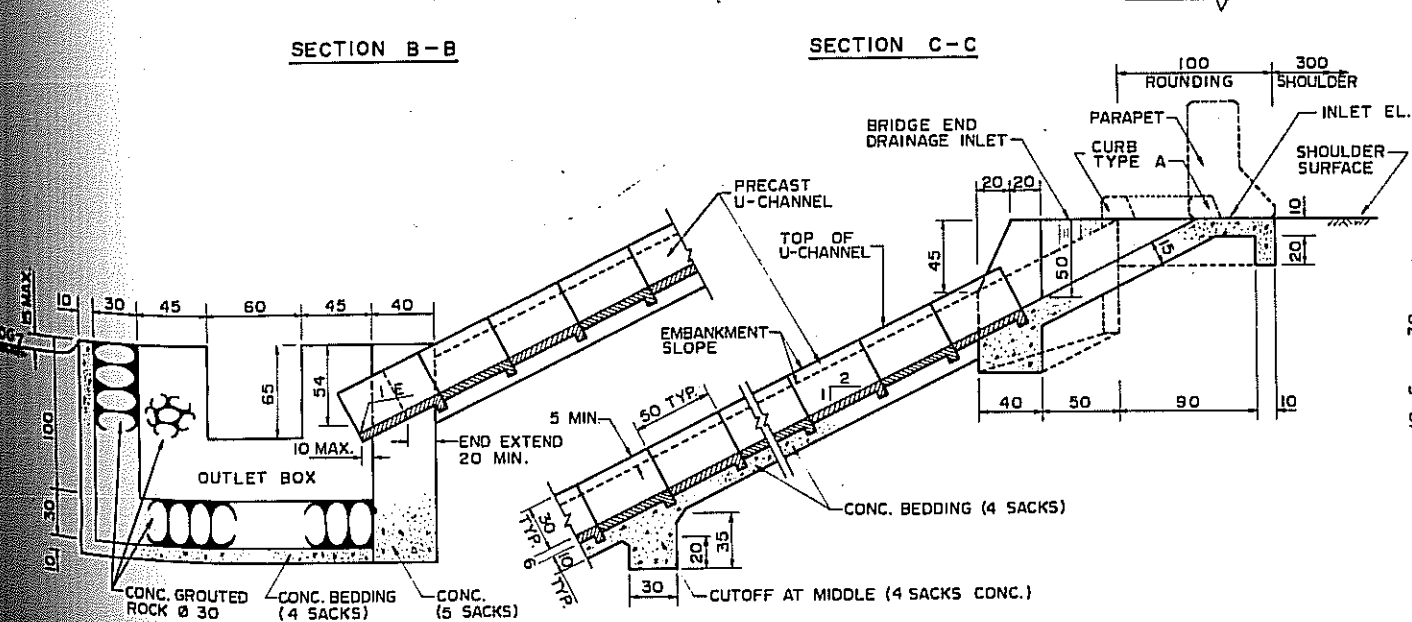

SECTION A-A

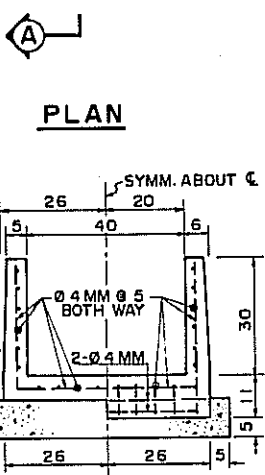

PLAN

TYP. SECTION

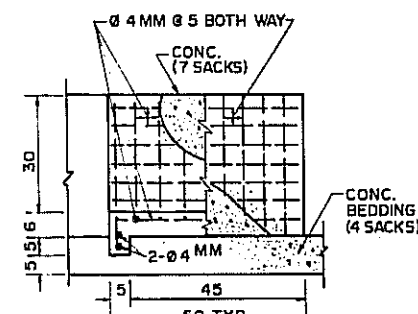

LONGITUDINAL SECTION

DETAILS OF PRECAST U-CHANNEL
(40X30X50)

ESTIMATED QUANTITIES OF PRECAST U-CHANNEL PER EACH
CONC. (7 SACKS): 0.034 M³, Ø 4 MM STEEL BARS: 2.2 KG.
BOTH OF CEMENT & STEEL BARS ARE NOT SUPPLIED
FORMS: 1.31 M².

橋端排水
BRIDGE END DRAINAGE

DRAINAGE STANDARD DETAILS

修正 REVISIONS	項目 ITEM	日期 DATE	交通部台灣區高速公路工程局 TAIWAN AREA FREEWAY CONSTRUCTION BUREAU 中華民國 南北高速公路 苗栗台中段		NORTH-SOUTH FREEWAY MIAOLI-TAICHUNG SECTION	
			橋端排水及路堤護坡		BRIDGE END DRAINAGE AND EMBANKMENT SLOPE PROTECTION	
			中華顧問工程司		CHINA ENGINEERING CONSULTANTS, INC.	
			日期 DATE AUG. 74		比例 SCALE NTS	
					圖號 SHEET DT-17	

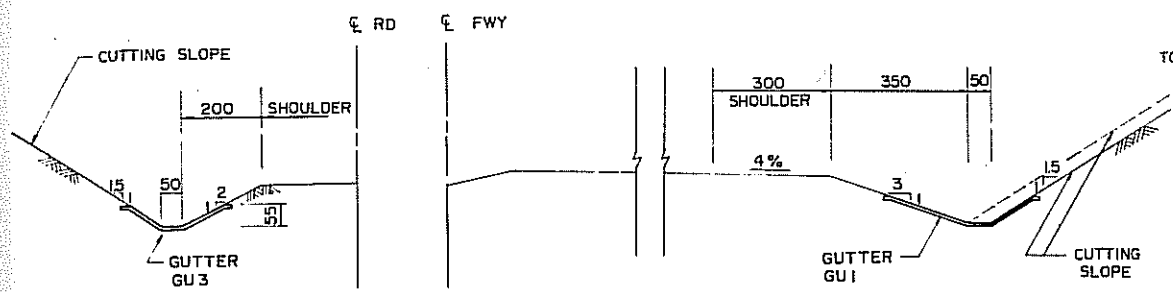

GUTTER LOCATION

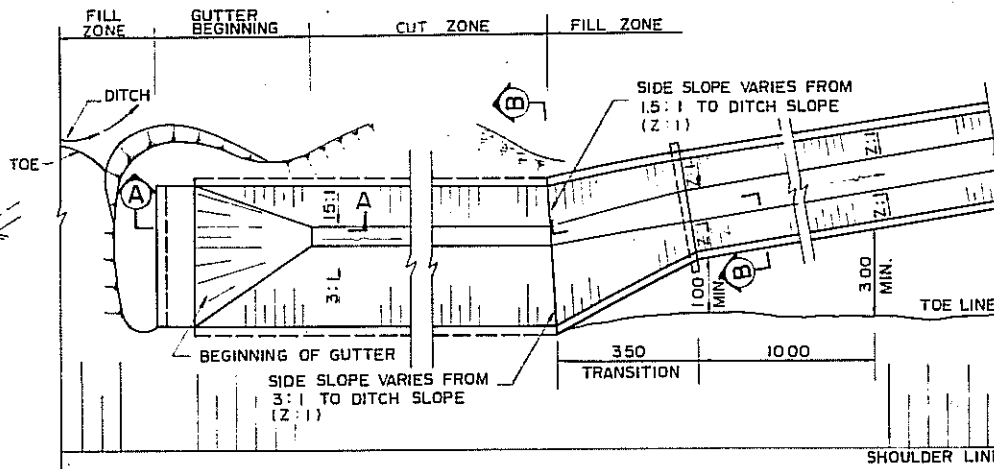

GENERAL LAYOUT OF GUTTER

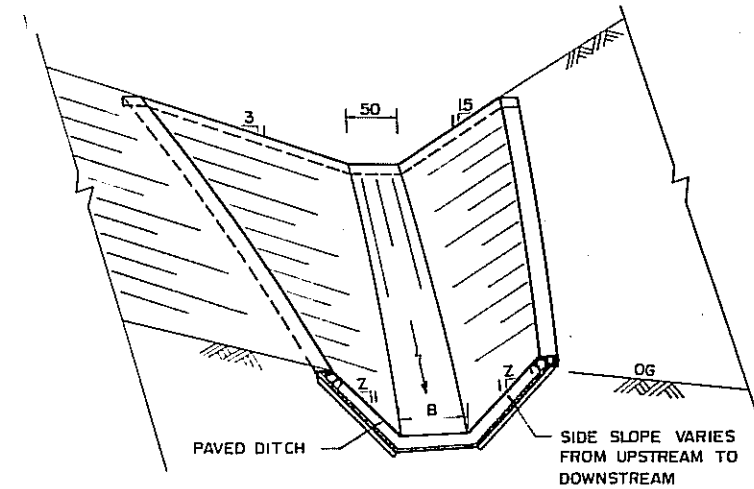

FRONT VIEW OF TRANSITION

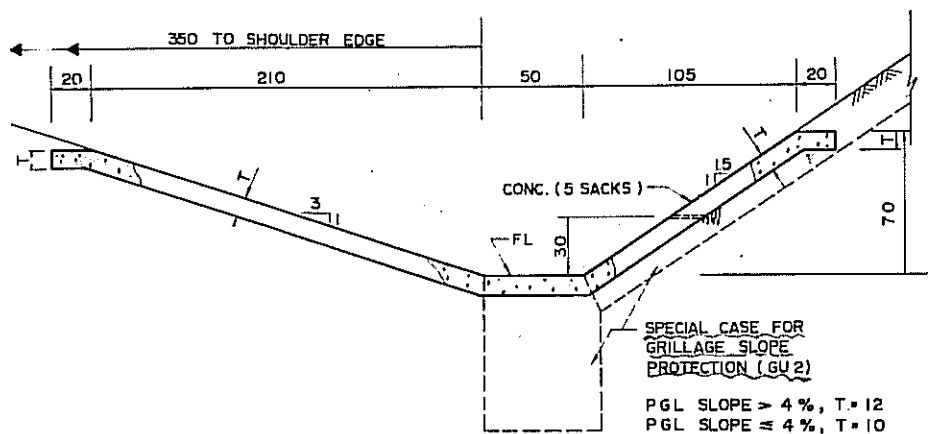

GUTTER, TYPE GU 1 & GU 2

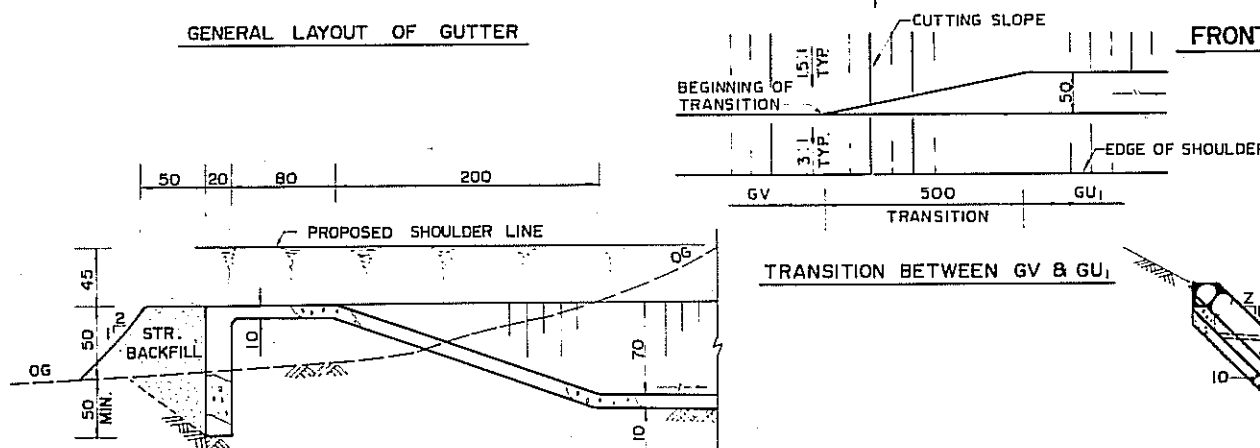

SECTION A-A

TRANSITION BETWEEN GV & GU1

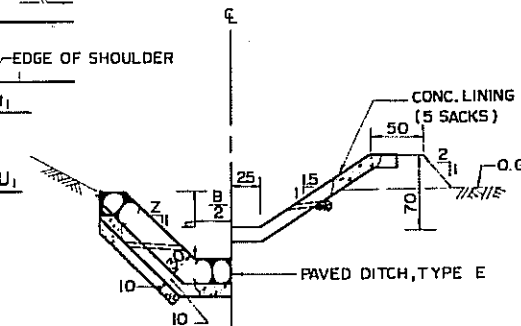

SECTION B-B

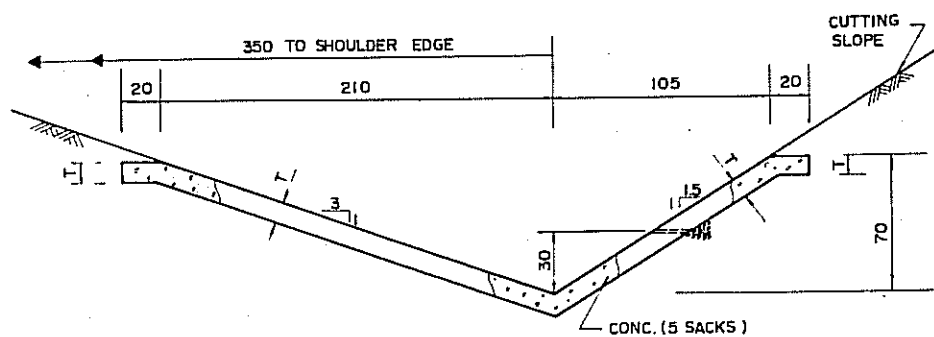

GUTTER, TYPE GV

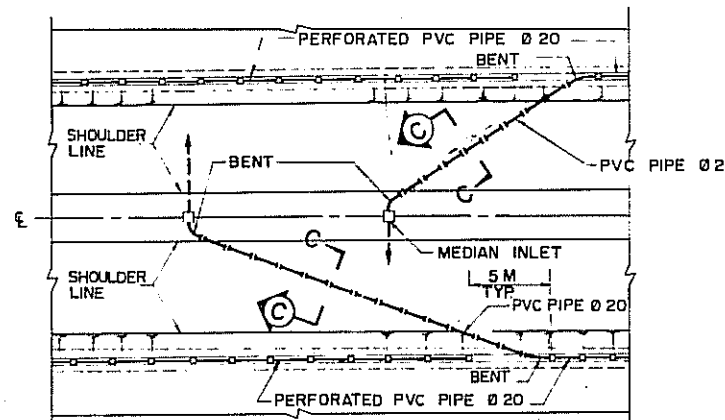

GENERAL LAYOUT OF SUB-DRAIN OUTLET

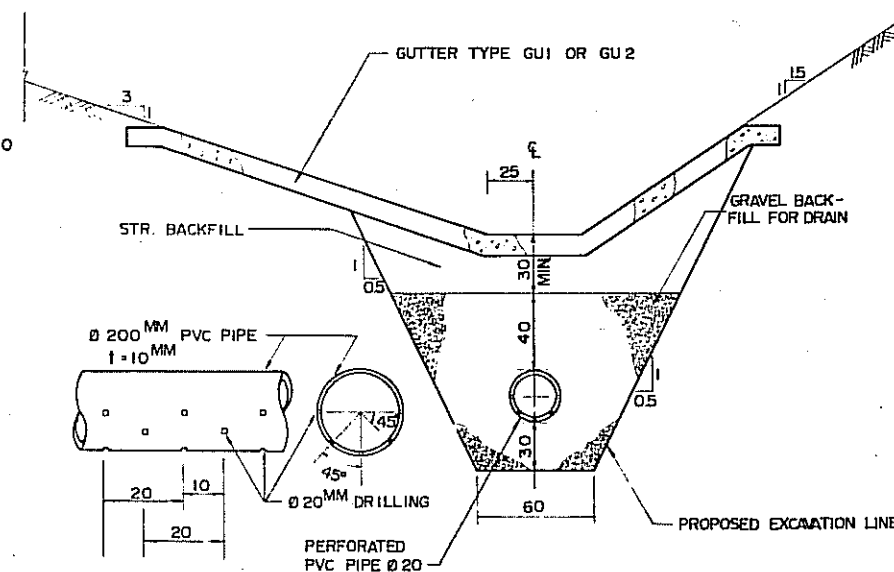

TYPICAL CROSS SECTION OF SUB DRAIN

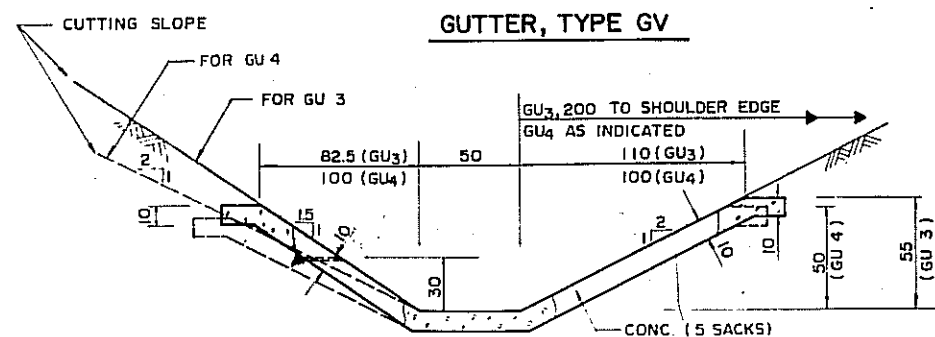

GUTTER, TYPE GU 3 & GU 4 (117 HWY)

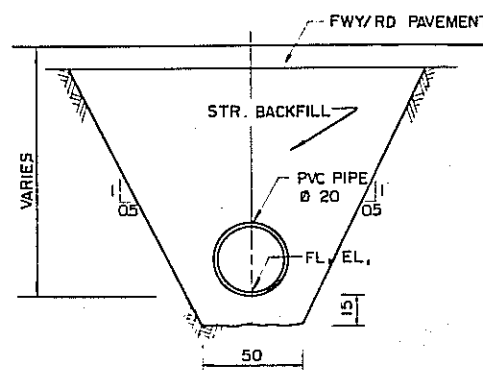

SECTION C-C

DRAINAGE STANDARD DETAILS

修正	REVISIONS	項目	ITEM	日期	DATE

交通部台灣區高速公路工程局
TAIWAN AREA FREEWAY CONSTRUCTION BUREAU
中華民國
REPUBLIC OF CHINA
南北高速公路 NORTH-SOUTH FREEWAY
苗栗台中段 MIAOLI-TAICHUNG SECTION
邊溝攔阻 LINED GUTTER
中華顧問工程司 CHINA ENGINEERING CONSULTANTS, INC.
日期 DATE AUG. 74 比例 SCALE NTS 圖號 SHEET DT-1B

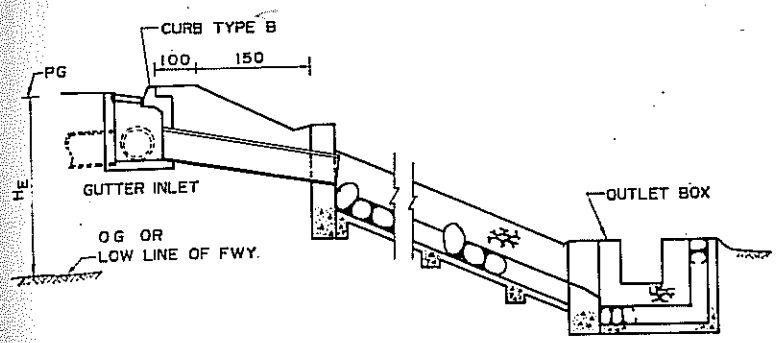

CASE I $H_E > 3M$
PROFILE

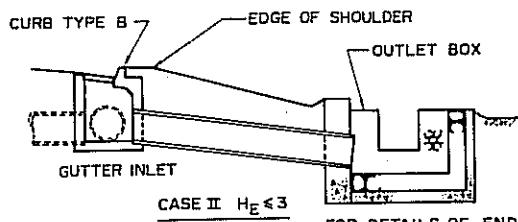

FOR DETAILS OF ENDWALL, CHUTE CHANNEL & OUTLET BOX SEE SHT. DT-15 & DT-16
PROFILE

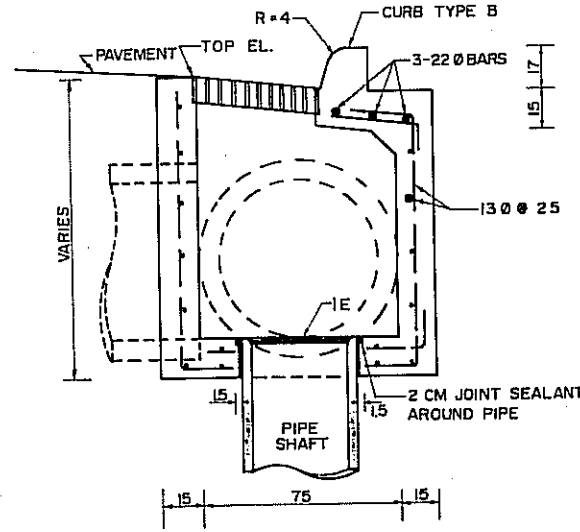

SECTION A-A

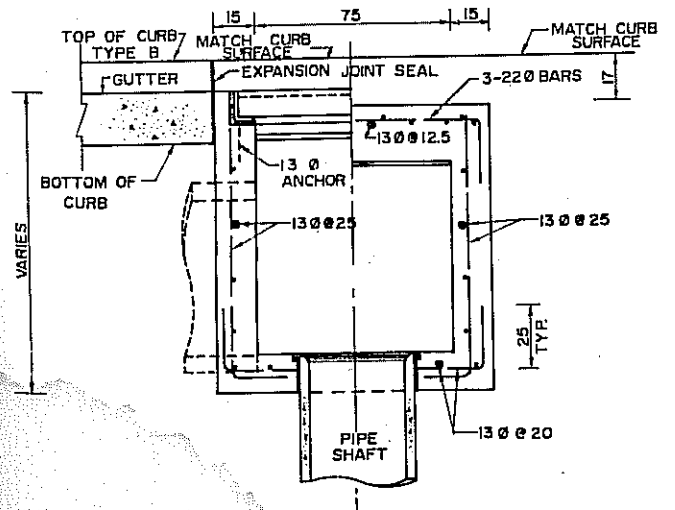

SECTION B-B

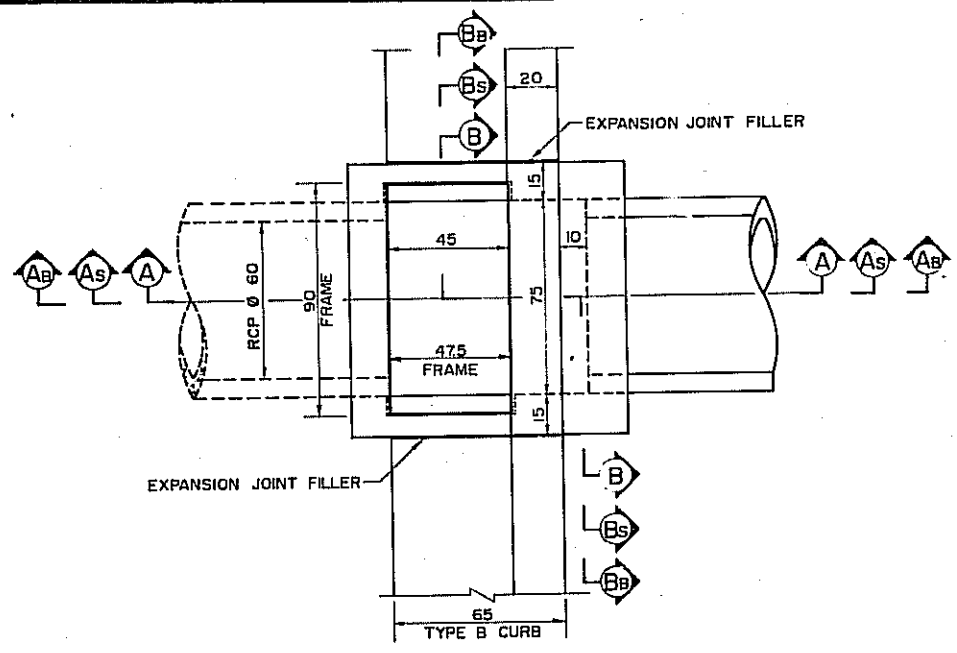

PLAN
(GRATING OMITTED FOR CLARITY)

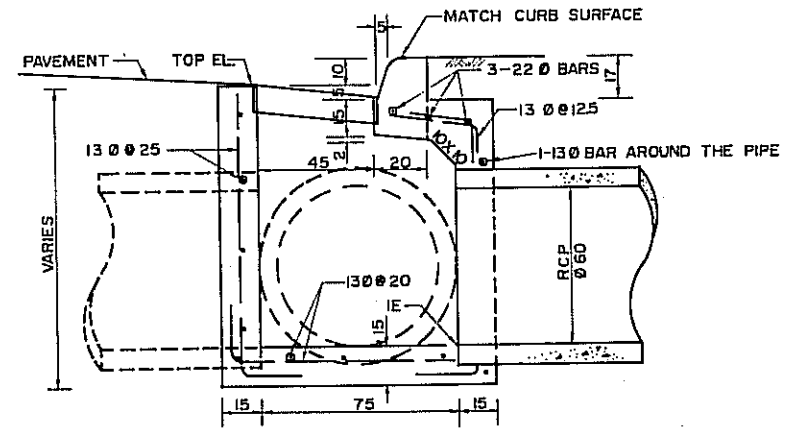

SECTION A-A

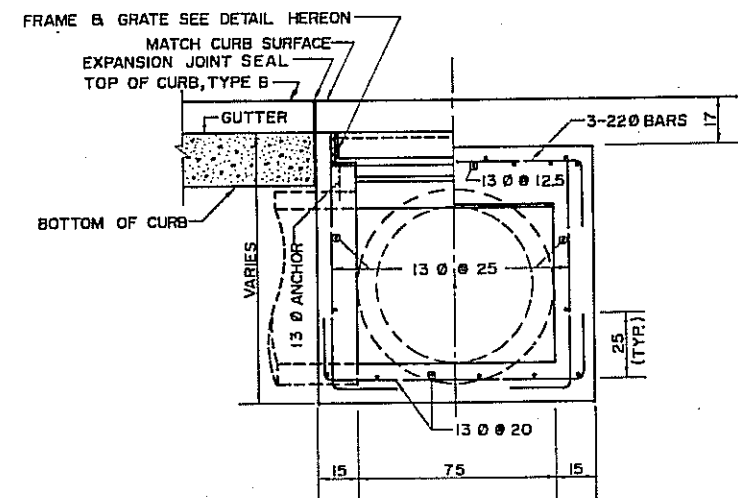

SECTION B-B

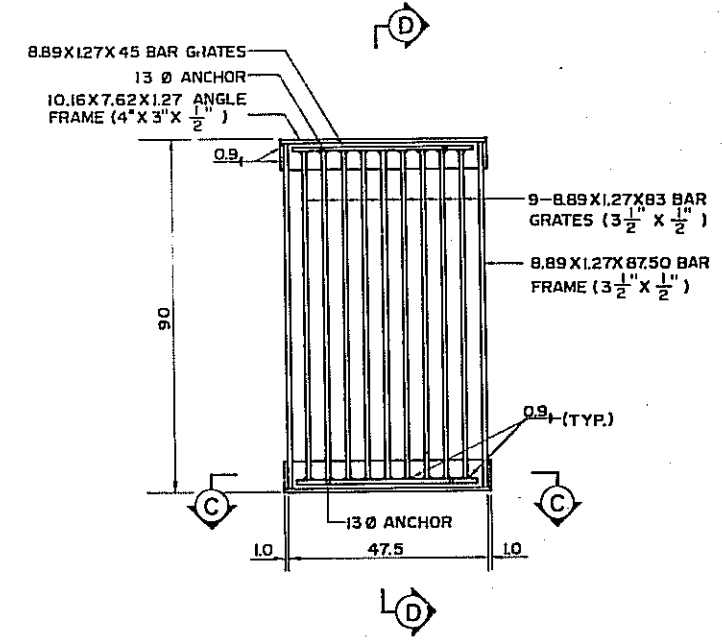

PLAN

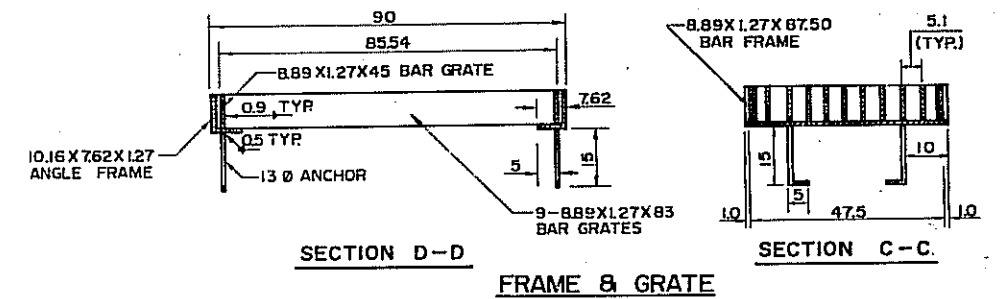

SECTION D-D

SECTION C-C

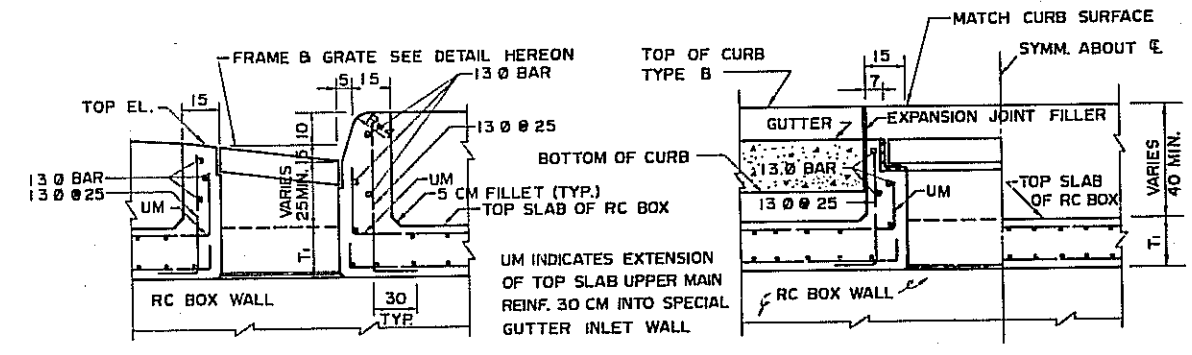

SECTION A-B

SECTION B-B

DRAIN INLET CONNECTED TO BOX CULVERT

DRAINAGE STANDARD DETAILS

修正	REVISIONS	項目	ITEM	日期	DATE

交通部台灣區高速公路工程局
TAIWAN AREA FREEWAY CONSTRUCTION BUREAU
中華民國
南北高速公路 NORTH-SOUTH FREEWAY
苗栗台中段 MIAOLI-TAICHUNG SECTION

邊溝進水井及排水口 GUTTER INLET & OUTLET
中華顧問工程司 CHINA ENGINEERING CONSULTANTS, INC.
日期 DATE AUG. '74 比例 SCALE NTS 圖號 SHEET DT-19

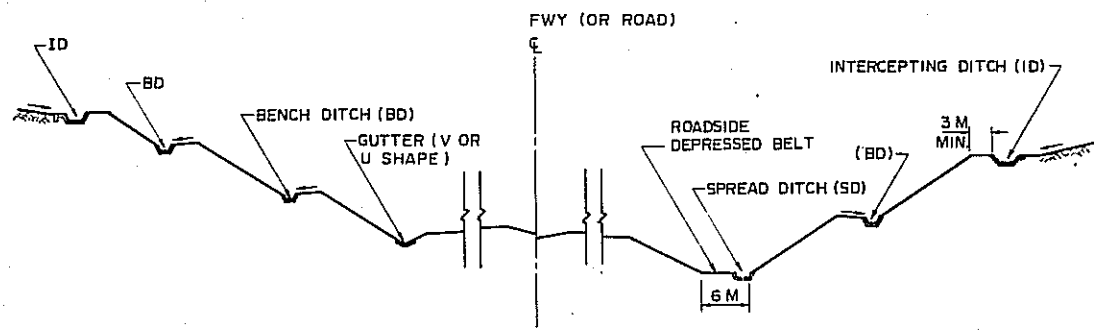

INTERCEPTING DITCH SYSTEM IN CUTTING AREA

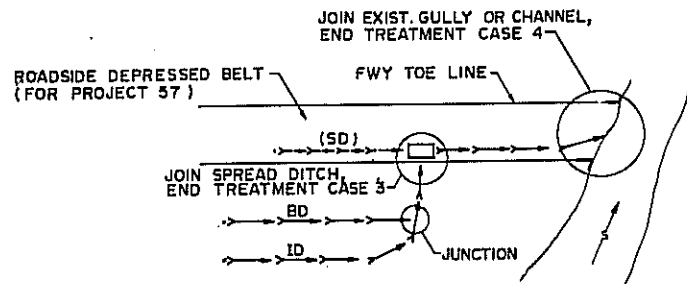
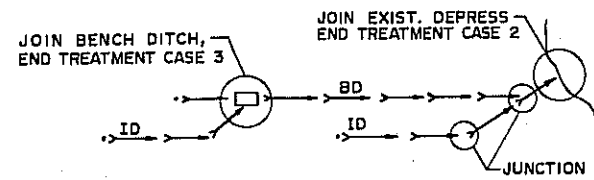
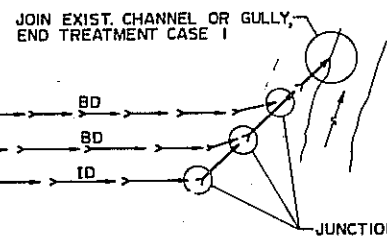

GENERAL LAYOUT OF INTERCEPTING DITCH SYSTEM

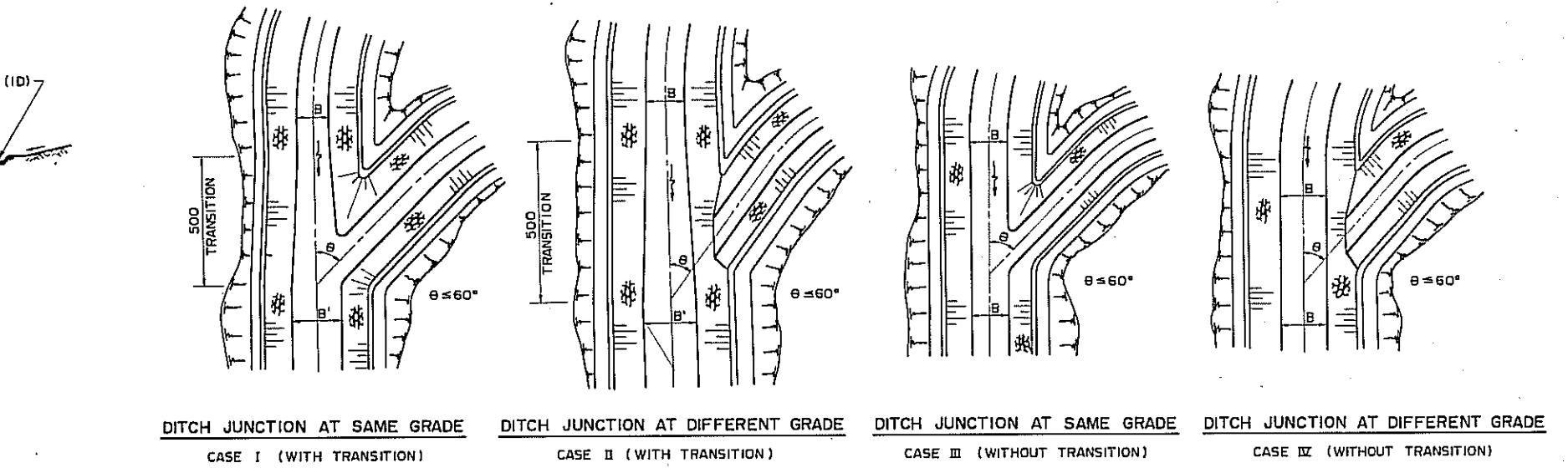
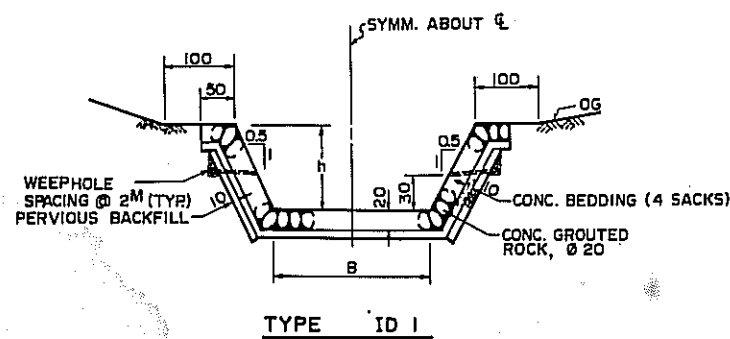

DITCH JUNCTION AT SAME GRADE CASE I (WITH TRANSITION) DITCH JUNCTION AT DIFFERENT GRADE CASE II (WITH TRANSITION) DITCH JUNCTION AT SAME GRADE CASE III (WITHOUT TRANSITION) DITCH JUNCTION AT DIFFERENT GRADE CASE IV (WITHOUT TRANSITION)

JUNCTION FOR INTERCEPTING DITCH SYSTEM

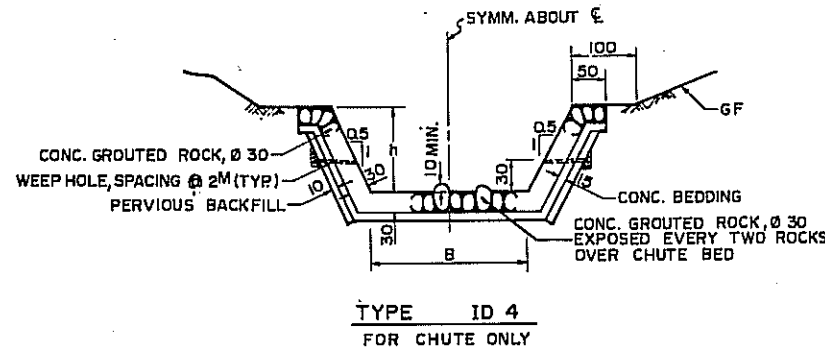
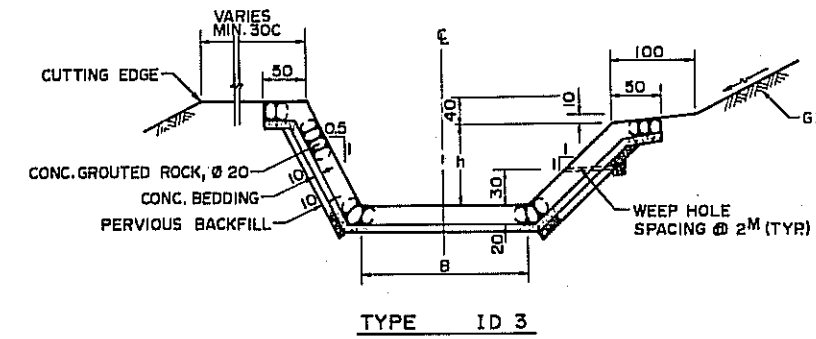
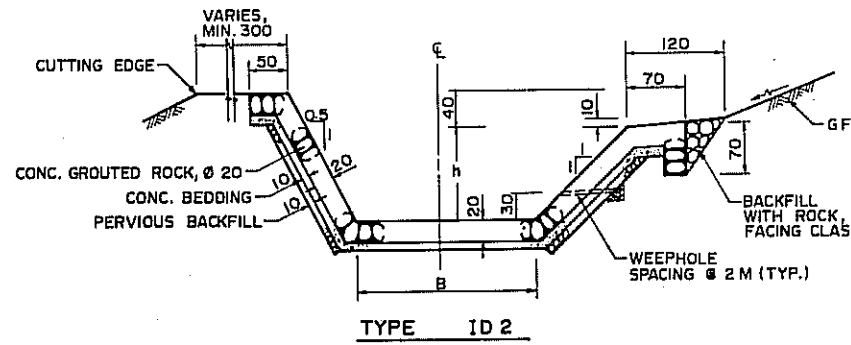

TYPICAL SECTIONS FOR INTERCEPTING DITCH

GF INDICATES THE GRADING AS FLAT AS POSSIBLE WITHIN ROW.

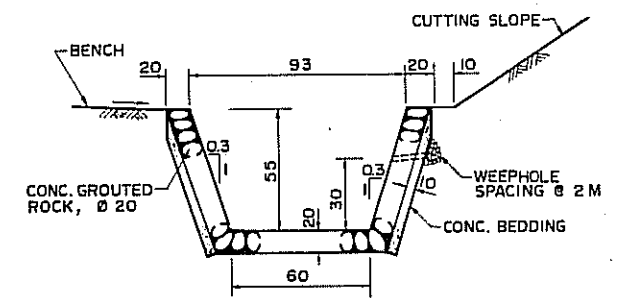

TYPE BD 1

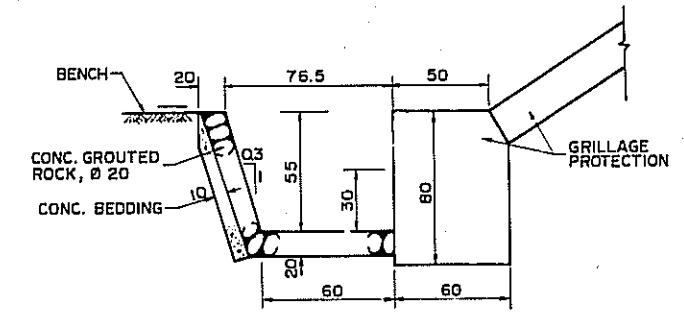

TYPE BD 2

TYPICAL SECTIONS FOR BENCH DITCH

DRAINAGE STANDARD DETAILS

修正 REVISIONS	項目 ITEM	日期 DATE

交通部台灣區高速公路工程局
TAIWAN AREA FREEWAY CONSTRUCTION BUREAU
中華民國 REPUBLIC OF CHINA
南北高速公路 NORTH-SOUTH FREEWAY
苗栗台中段 MIAOLI-TAICHUNG SECTION
截流溝系統(I) INTERCEPTING DITCH SYSTEM (I)
中華顧問工程司 CHINA ENGINEERING CONSULTANTS, INC.
日期 DATE AUG. '74 比例 SCALE NTS 圖號 SHEET DT-20

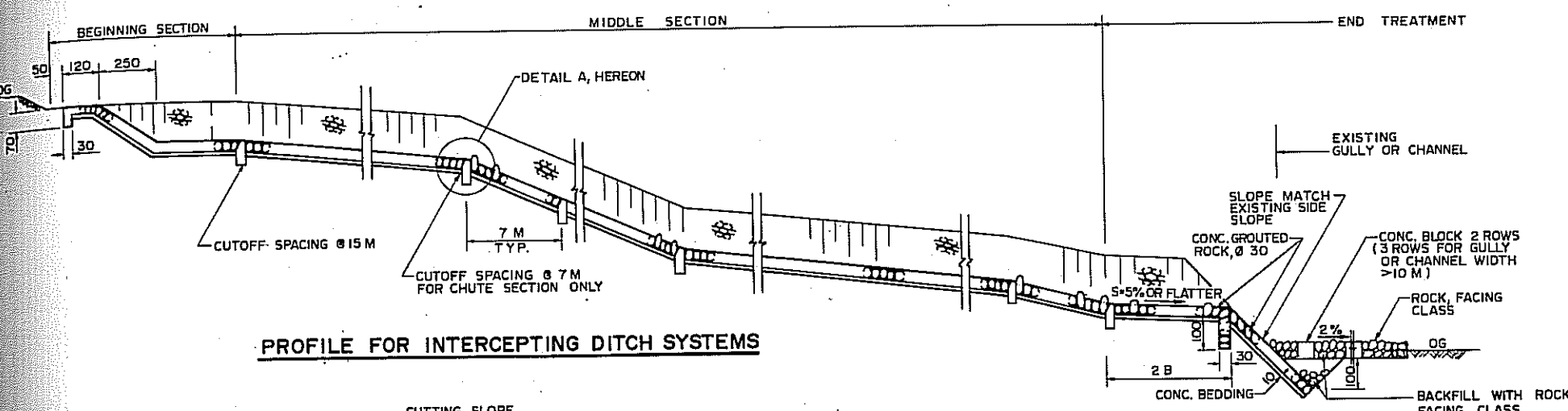

PROFILE FOR INTERCEPTING DITCH SYSTEMS

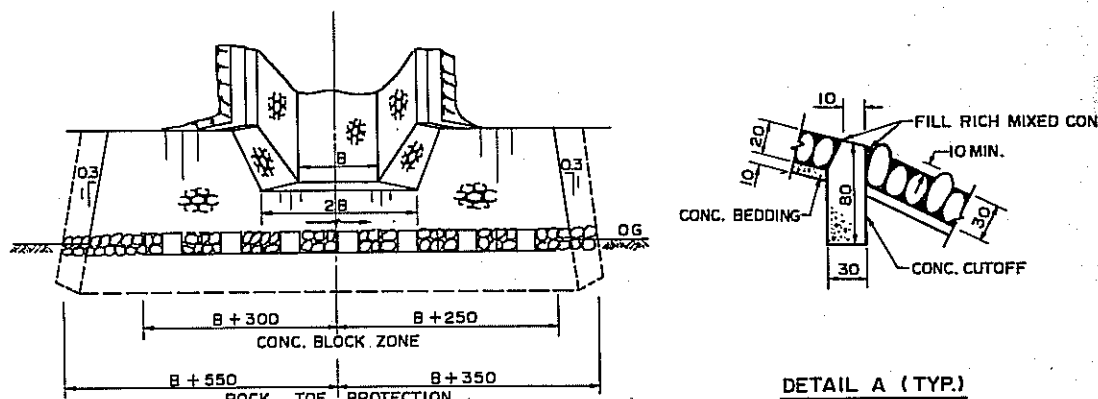

FRONT VIEW

DETAIL A (TYP.)

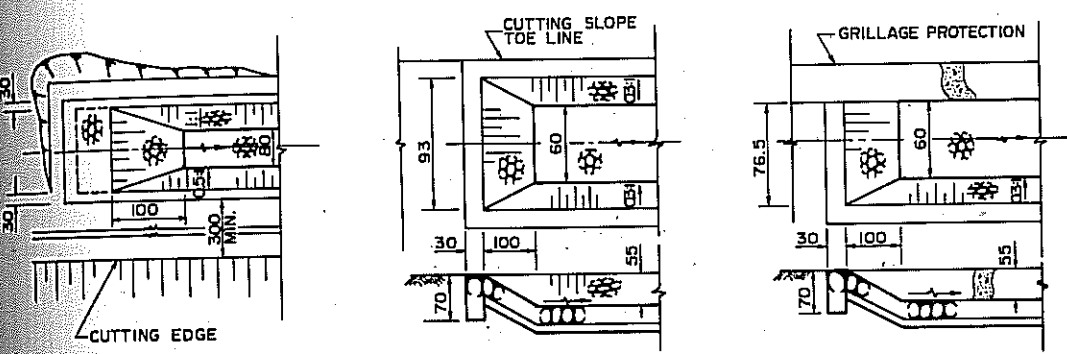

PLAN OF BEGINNING SECTION FOR ID

DETAILS OF BEGINNING SECTION FOR BD 1

DETAILS OF BEGINNING SECTION FOR BD 2

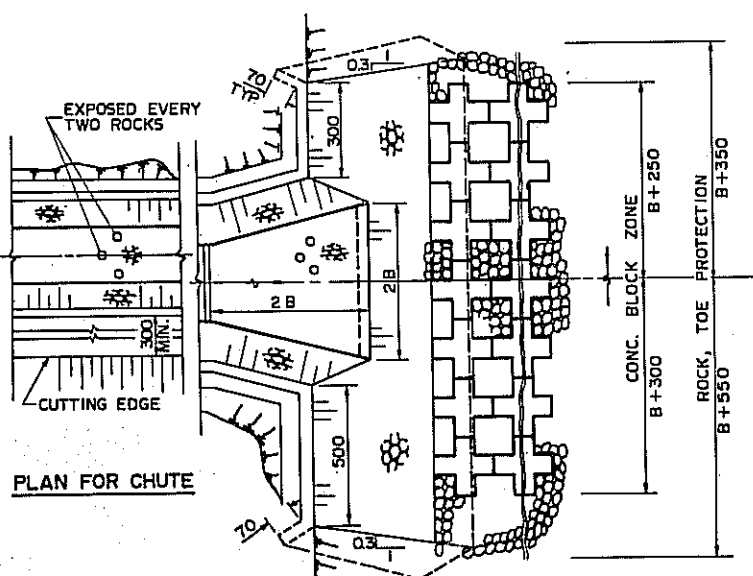

FOR END TREATMENT CASE I

PLAN FOR CHUTE

DETAILS FOR END TREATMENT, CASE I

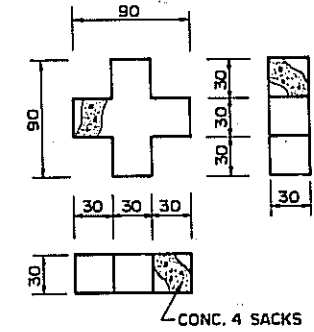

CONC. BLOCK DETAILS CAST IN PLACE

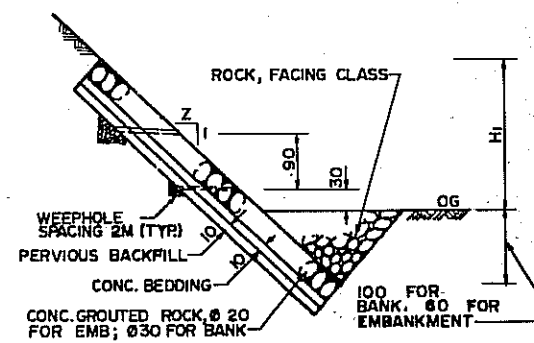

TYPICAL SECTION OF EMBANKMENT AND BANK SLOPE PROTECTION FOR ID SYSTEM

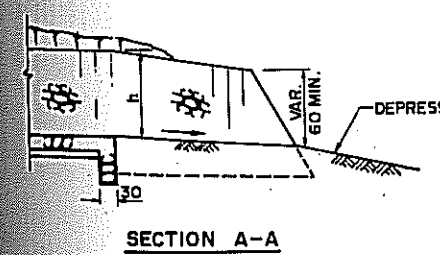

SECTION A-A

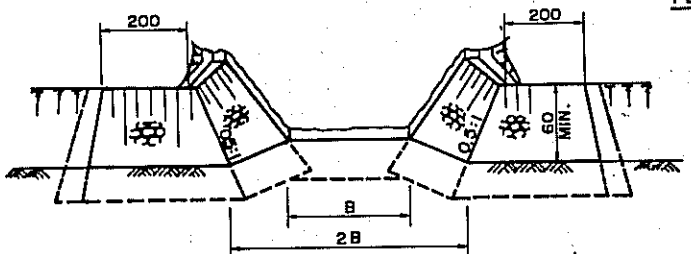

FRONT VIEW

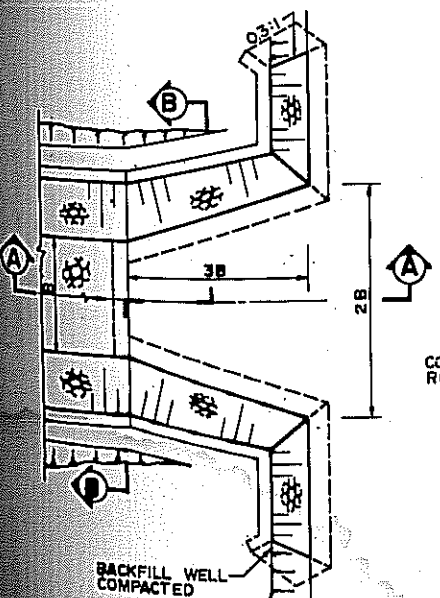

PLAN

DETAILS FOR END TREATMENT, CASE 2

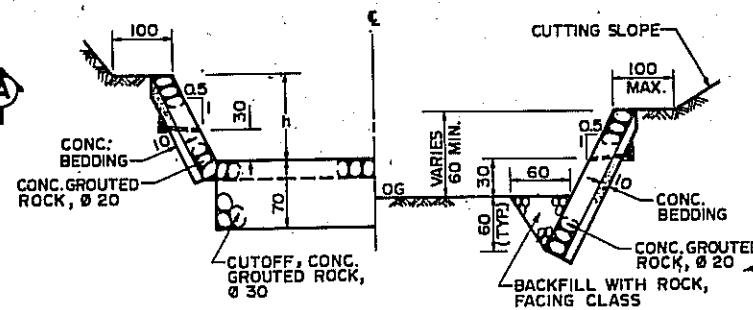

SECTION B-B

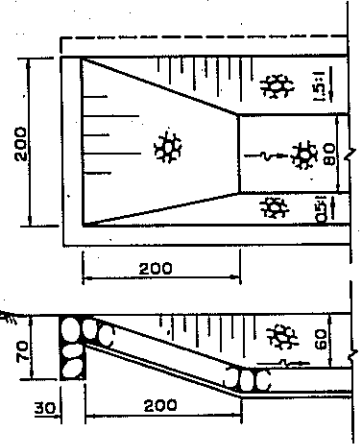

DETAILS OF BEGINNING SECTION FOR SD

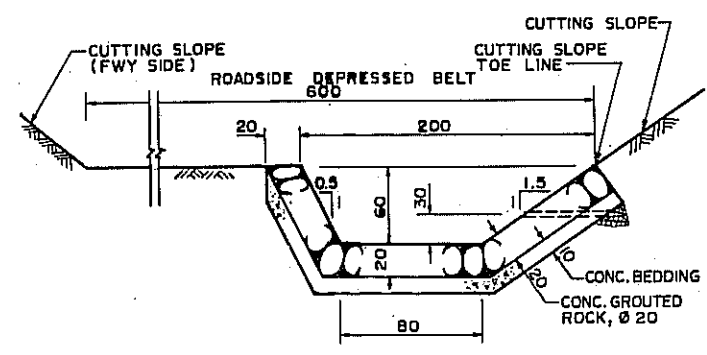

TYPICAL SECTION OF SPREAD DITCH (SD) (FOR PROJECT 57)

修正 REVISIONS		日期 DATE	
项目 ITEM		日期 DATE	

交通部台灣區高速公路工程局
TAIWAN AREA FREEWAY CONSTRUCTION BUREAU
中華民國
REPUBLIC OF CHINA
南北高速公路 NORTH-SOUTH FREEWAY
苗栗台中段 MIAOLI-TAICHUNG SECTION
截流溝系統(II) INTERCEPTING DITCH SYSTEM (II)
中華顧問工程司 CHINA ENGINEERING CONSULTANTS, INC.
日期 DATE AUG. 74 比例 SCALE NTS 圖號 SHEET DT-21

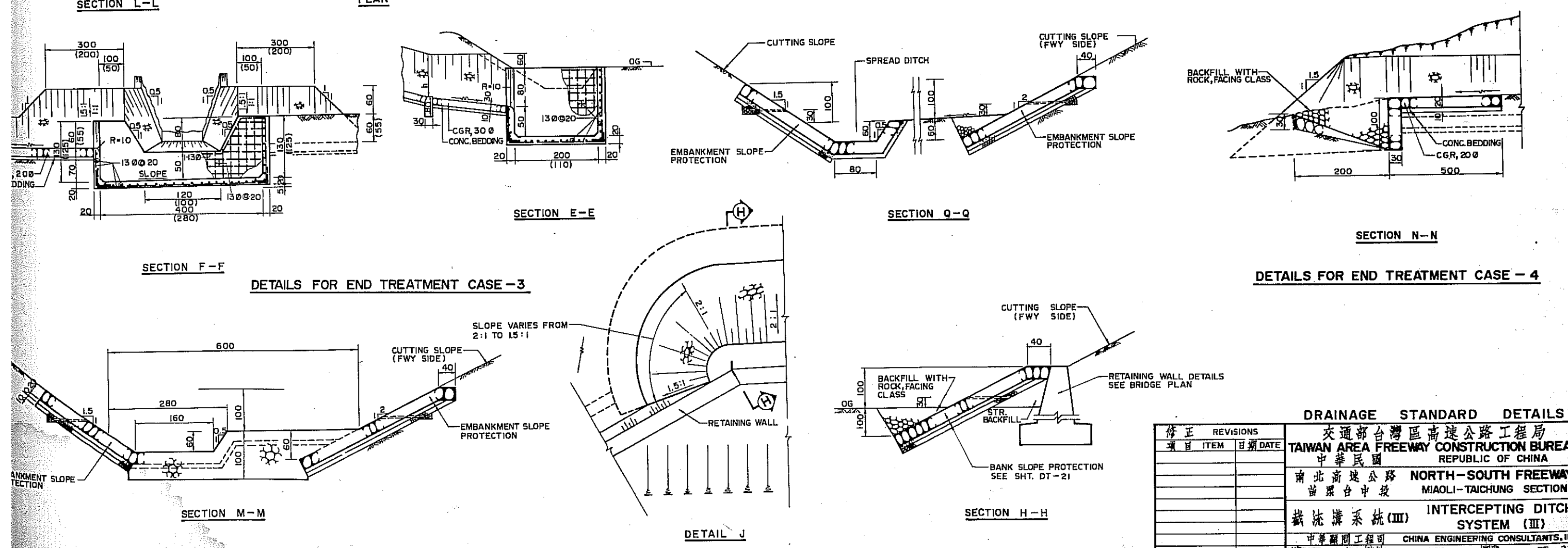
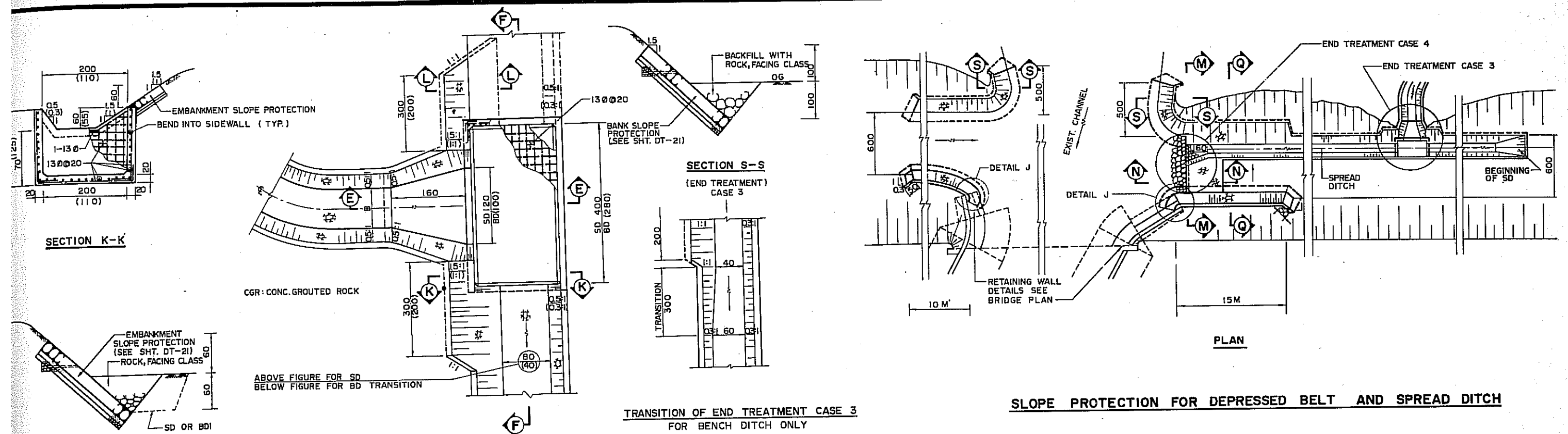

修正	REVISIONS	項目	ITEM	日期	DATE

DRAINAGE STANDARD DETAILS

交通部台灣區高速公路工程局
TAIWAN AREA FREEWAY CONSTRUCTION BUREAU
中華民國
REPUBLIC OF CHINA
南北高速公路
NORTH-SOUTH FREEWAY
苗栗台中段
MIAOLI-TAICHUNG SECTION

截流溝系統(III)
INTERCEPTING DITCH SYSTEM (III)

中華顧問工程司
CHINA ENGINEERING CONSULTANTS, INC.
日期 DATE AUG. 74 比例 SCALE NTS 圖號 SHEET DT-22

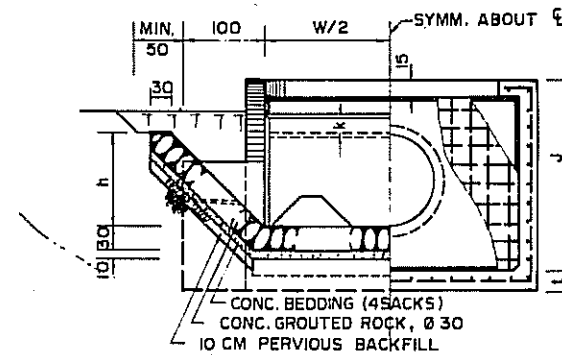
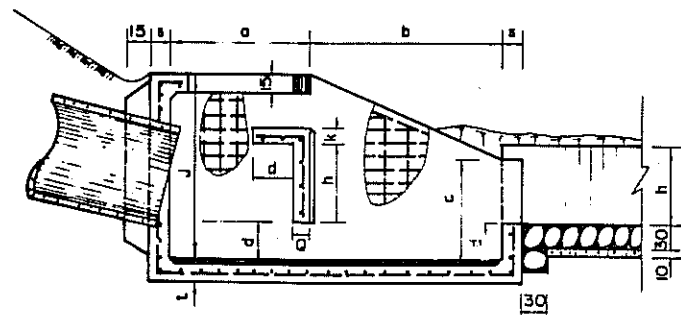
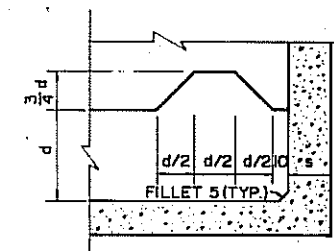
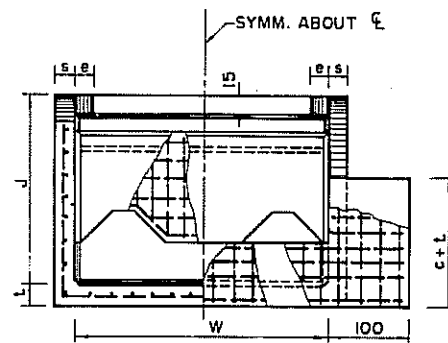
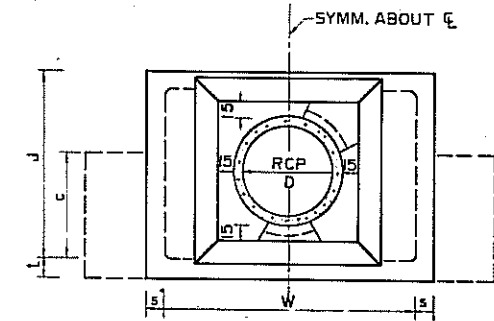
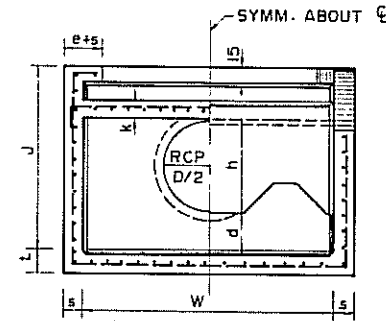
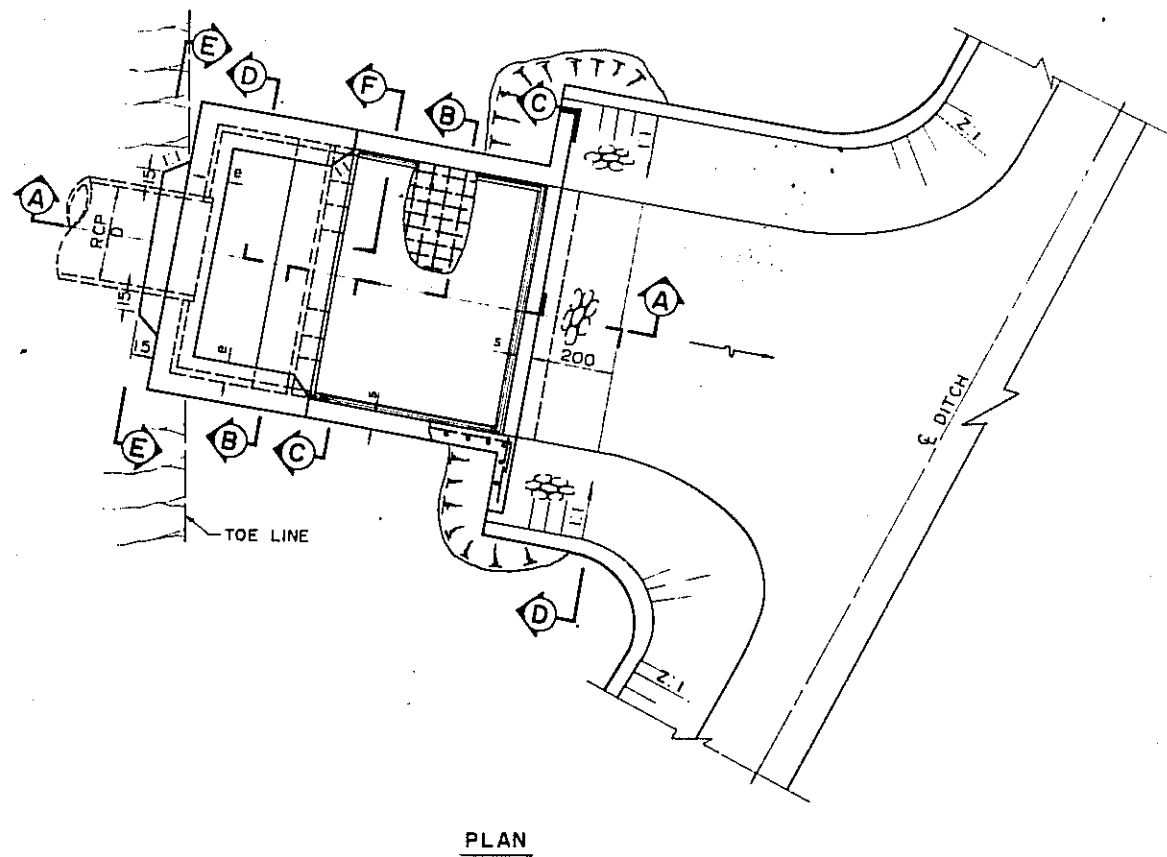

DIMENSIONS OF ENERGY DISSIPATOR (CM)

D	W	J	a	b	c	d	e	h	k	ø	t	s
60	210	160	120	160	90	35	18	80	15	15	16	16
80	250	200	140	190	100	43	20	95	18	18	18	18
100	320	240	180	240	130	53	25	120	20	23	23	23
120	350	270	200	270	150	60	25	130	20	25	23	23
150	430	320	240	330	175	70	30	160	20	28	28	28

ALL REINFORCING STEEL BARS ARE Ø13 A1 SPACING @ 20 CM

DRAINAGE STANDARD DETAILS

修正	REVISIONS	項目	ITEM	日期	DATE

交通部台灣區高速公路工程局
TAIWAN AREA FREEWAY CONSTRUCTION BUREAU
中華民國
中華人民共和國
南北高速公路 NORTH-SOUTH FREEWAY
苗栗台中段 MIAOLI-TAICHUNG SECTION
管涵消能箱 PIPE CULVERT ENERGY DISSIPATOR
中華顧問工程司 CHINA ENGINEERING CONSULTANTS, INC.
日期 DATE AUG. '74 比例 SCALE NTS 圖號 SHEET DT-23

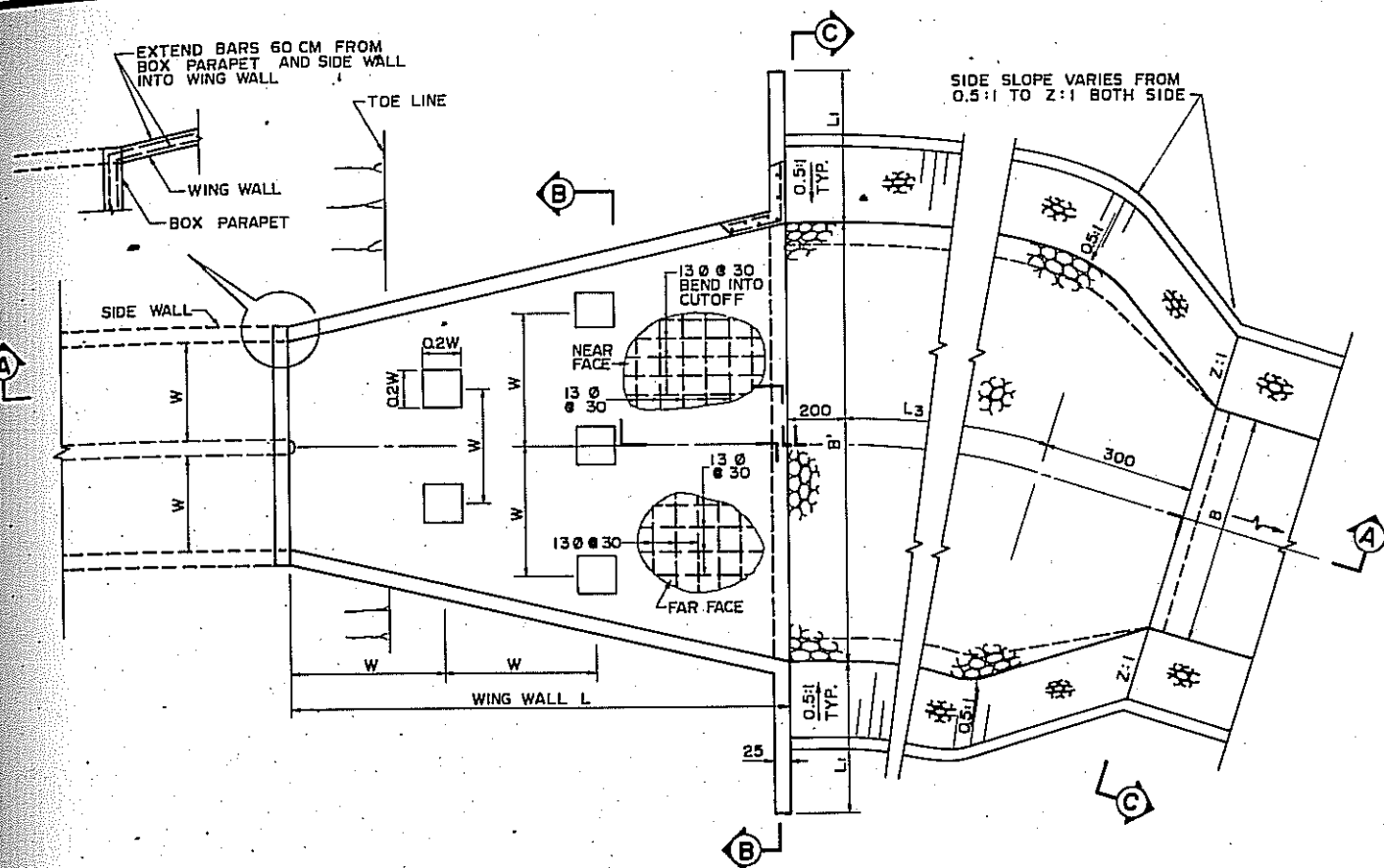

PLAN (FOR DOUBLE RC BOX)

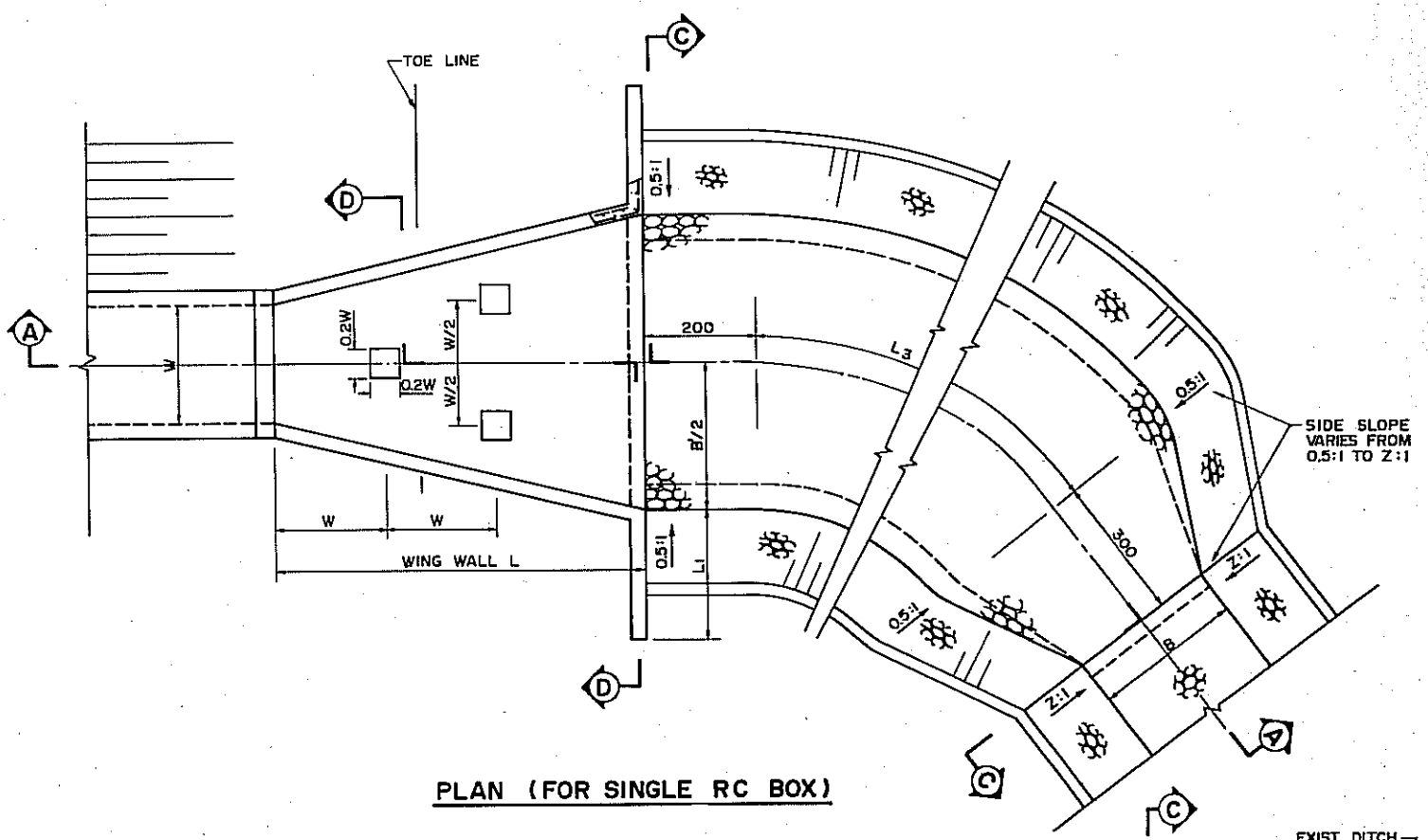

PLAN (FOR SINGLE RC BOX)

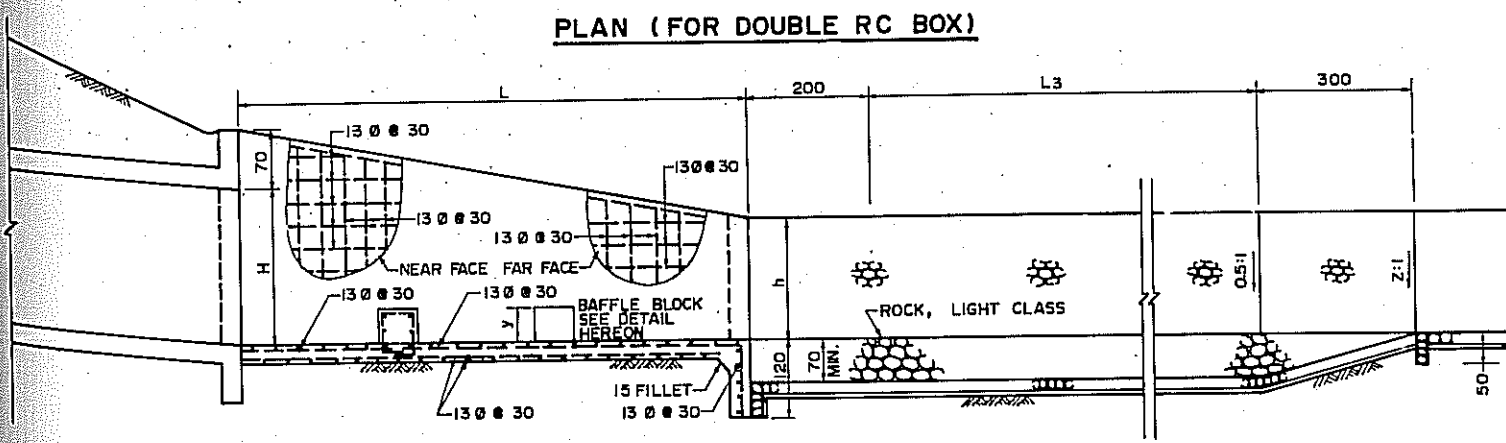

SECTION A-A

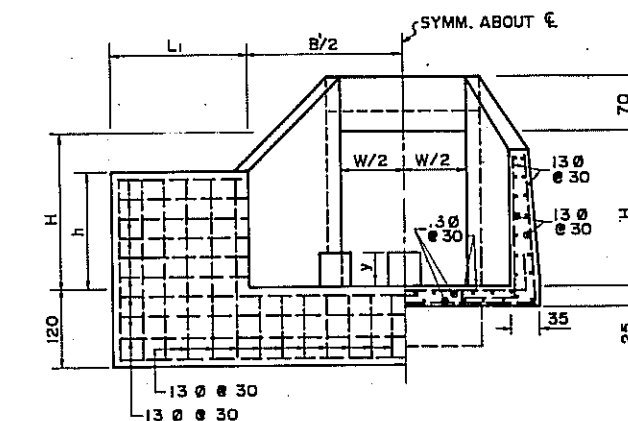

SECTION D-D

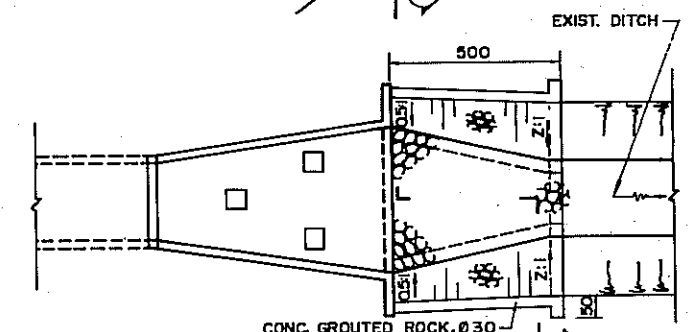

PLAN (FOR CASE OF NONPAVED CHANNEL)

DIMENSIONS OF BOX CULVERT ENERGY DISSIPATOR

BOX SIZE (M)	DIMENSIONS (CM)							
	W	H	L	L1	B'	h	y	L3
1-2.0x2.0	200	200	550	130	335	150	35	2.00
1-2.5x2.0	250	200	650	130	385	150	35	2.50
1-2.5x2.5	250	250	650	150	385	200	60	2.50
1-3.0x2.0	300	200	750	130	435	150	35	3.00
2-2.5x2.5	250	250	650	150	635	200	60	5.00
1-2.0x1.5	200	150	550	110	335	120	35	2.00

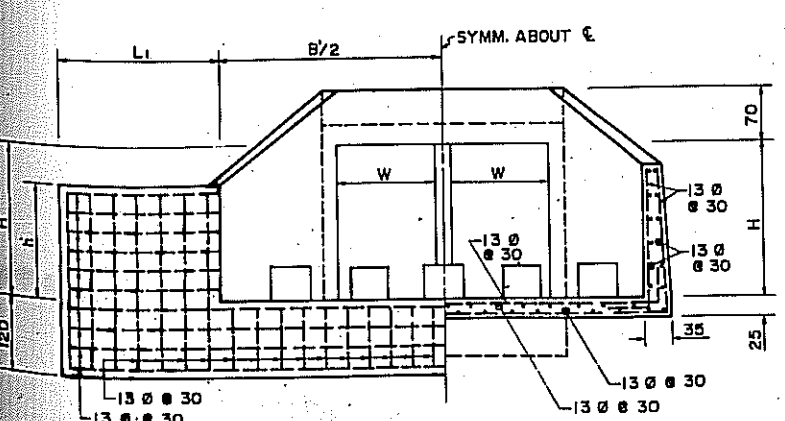

SECTION B-B

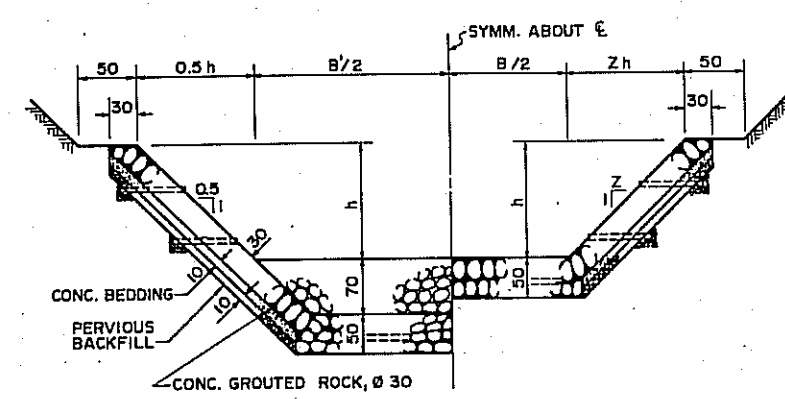

SECTION C-C

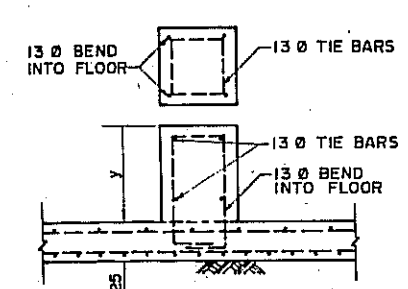

BAFFLE BLOCK

DRAINAGE STANDARD DETAILS

修正 REVISIONS
項目 ITEM 日期 DATE

交通部台灣區高速公路工程局
TAIWAN AREA FREEWAY CONSTRUCTION BUREAU
中華民國
南北高速公路 NORTH-SOUTH FREEWAY
苗栗台中段 MIAOLI-TAICHUNG SECTION

箱涵消能設施 BOX CULVERT ENERGY DISSIPATOR

中華顧問工程司 CHINA ENGINEERING CONSULTANTS, INC.
日期 DATE AUG. 74 比例 SCALE NTS 圖號 SHEET DT-24

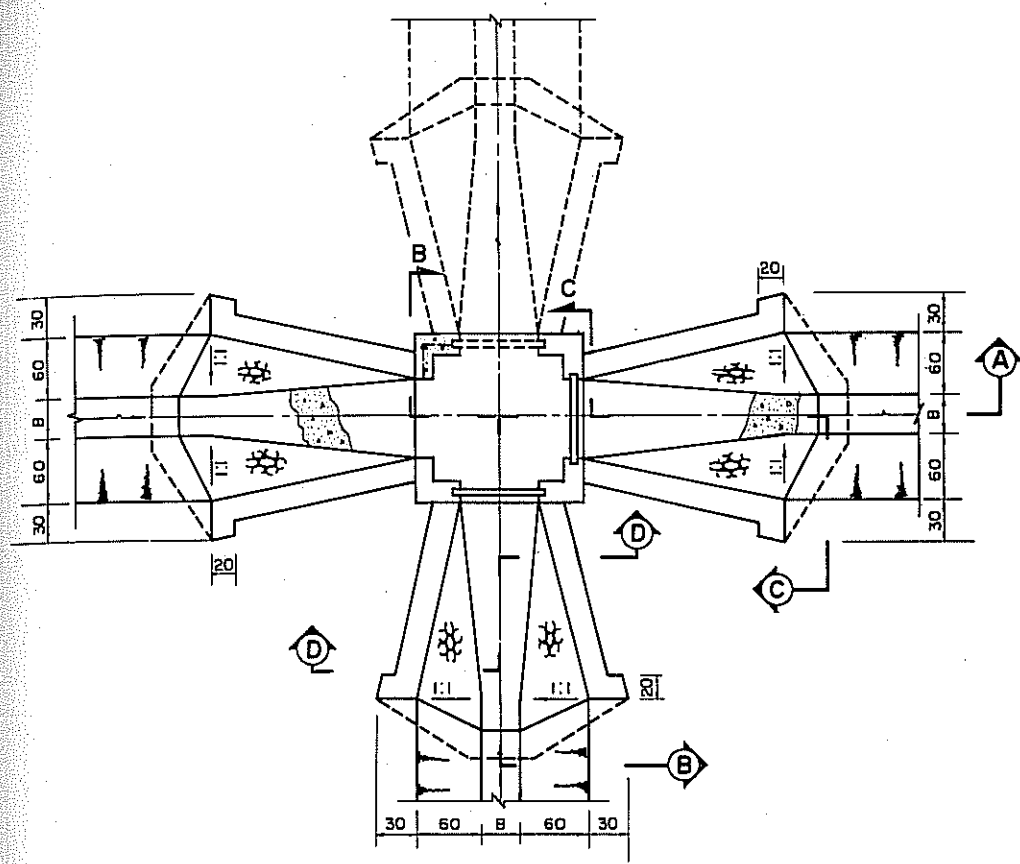

PLAN (CASE I)

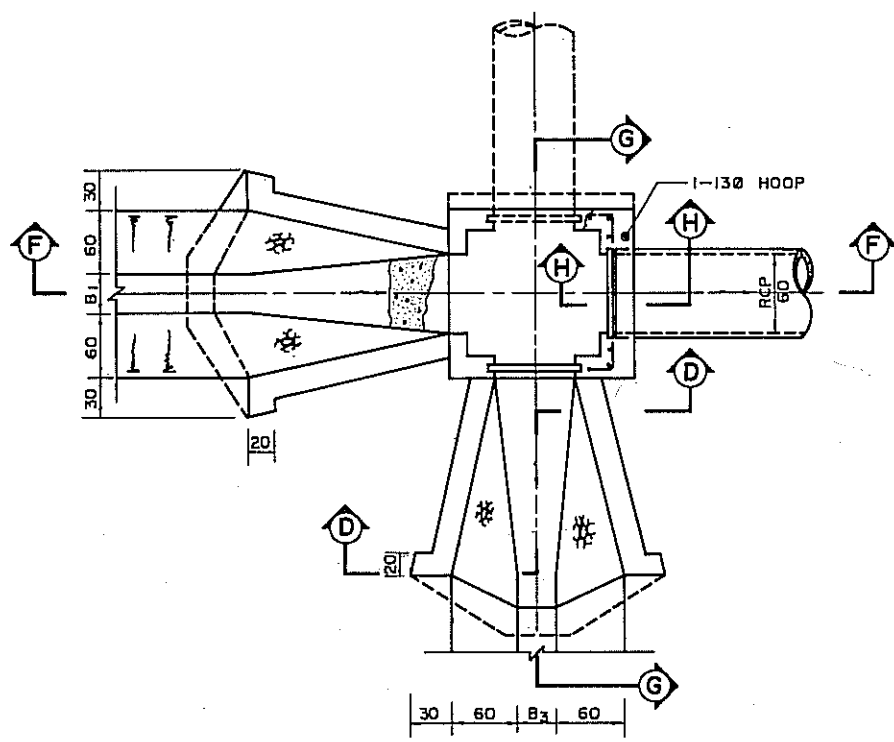

PLAN (CASE II)

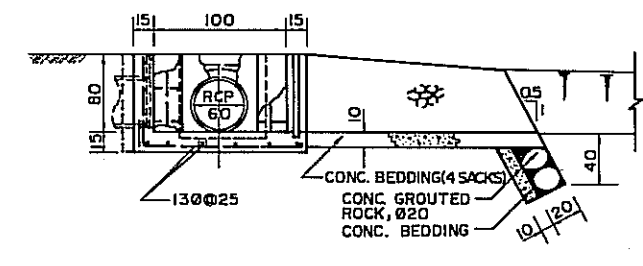

SECTION G-G

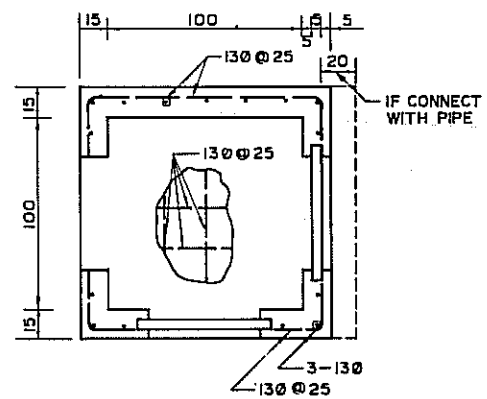

PLAN OF RC BOX

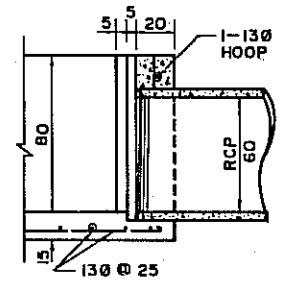

SECTION H-H

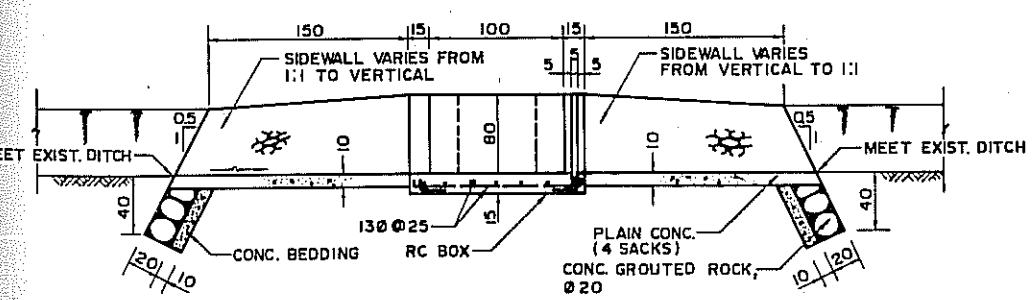

SECTION A-A

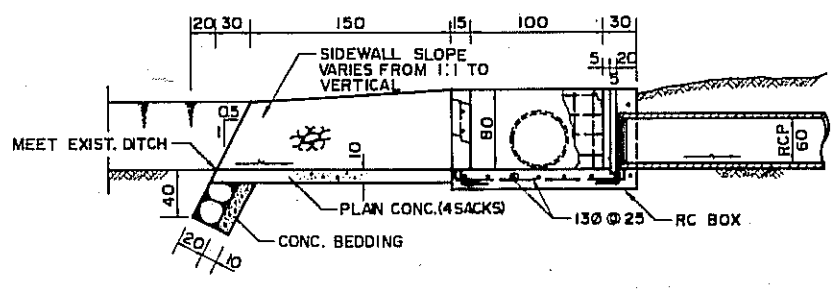

SECTION F-F

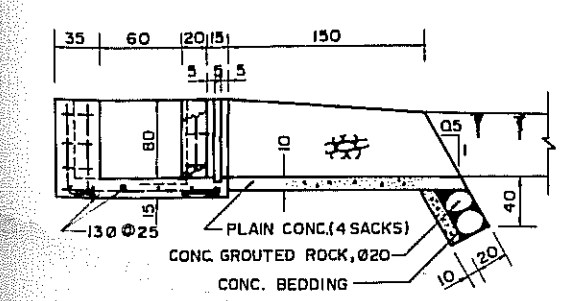

SECTION B-B

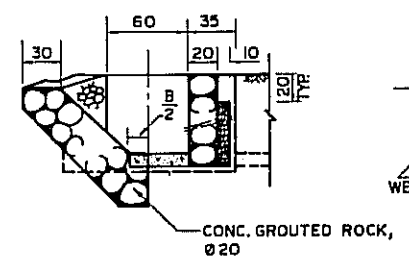

SECTION C-C

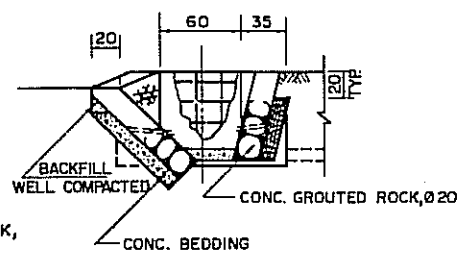

SECTION D-D

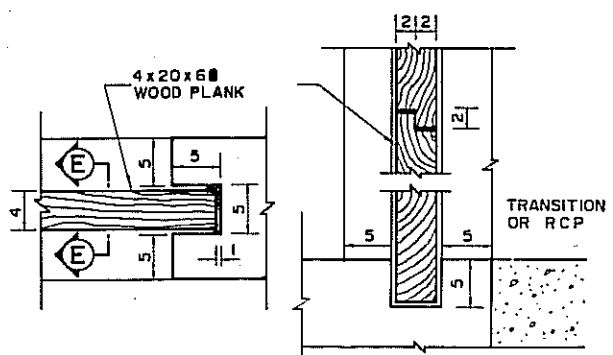

WOOD PLANK DETAILS

DRAINAGE STANDARD DETAILS

修正	REVISIONS
項目	ITEM
日期	DATE

交通部台灣區高速公路工程局
TAIWAN AREA FREEWAY CONSTRUCTION BUREAU
 中華民國
 南北高速公路 NORTH-SOUTH FREEWAY
 苗栗台中段 MIAOLI-TAICHUNG SECTION
 分水箱 FARM TURNOUT
 中華顧問工程司 CHINA ENGINEERING CONSULTANTS, INC.
 日期 DATE AUG. '74 比例 SCALE NTS 圖號 SHEET DT-25

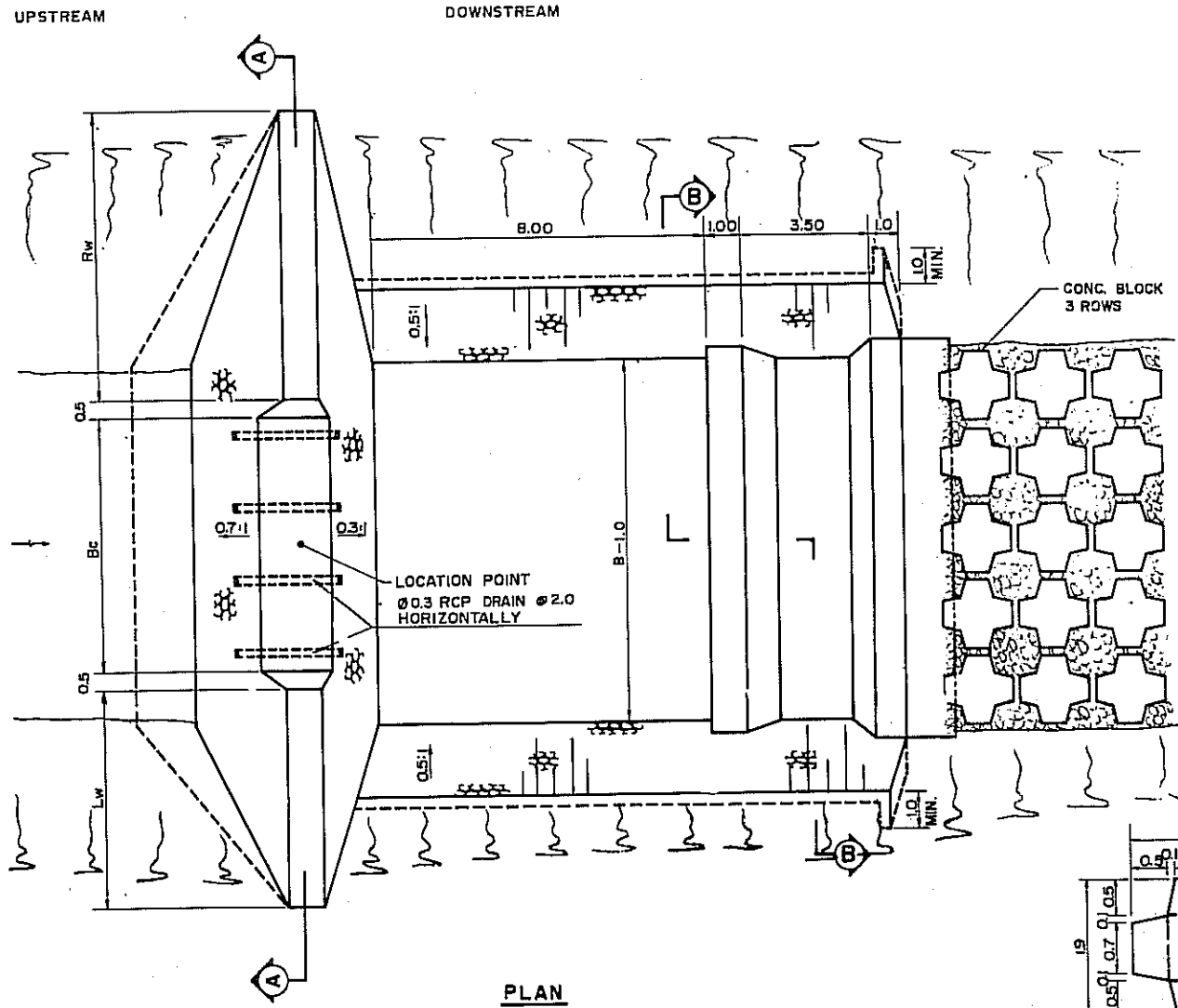

PLAN

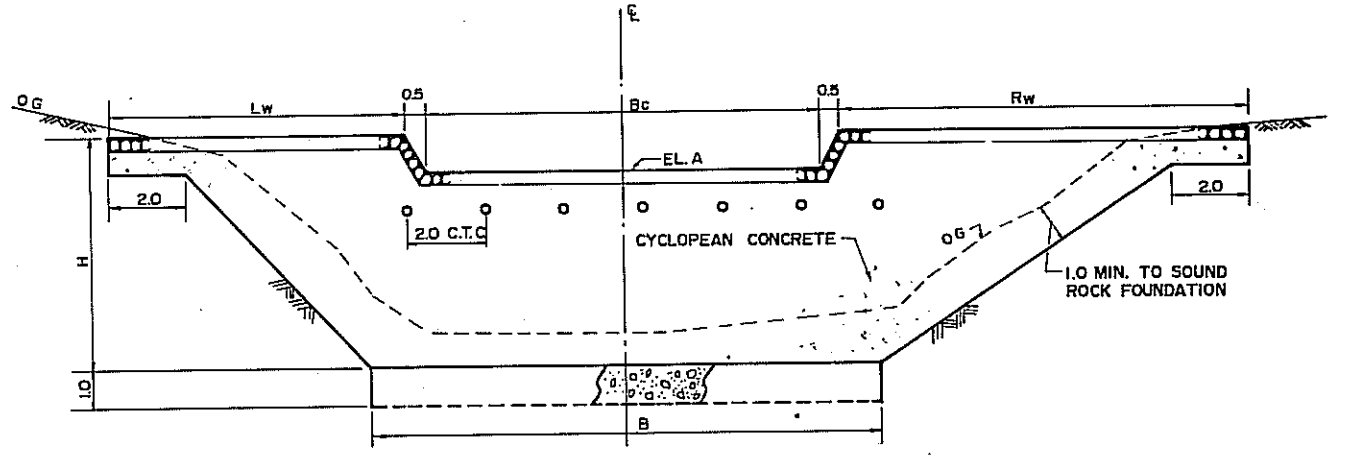

SECTION A-A

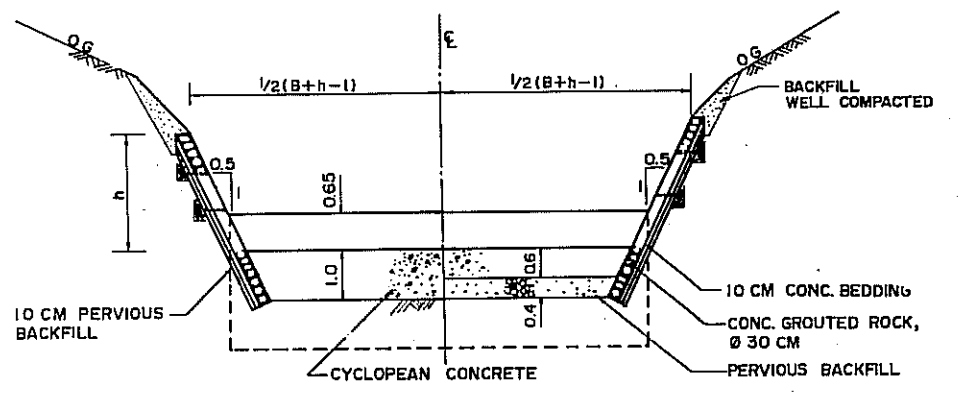

SECTION B-B

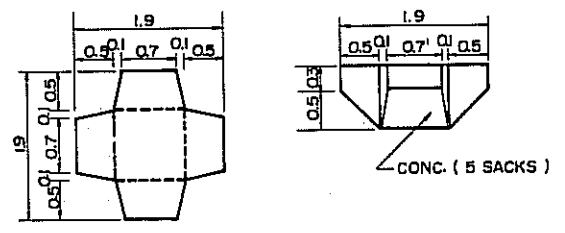

PLAN ELEVATION

DETAIL OF CONC. BLOCK

LIST OF SOIL SAVING DAMS

LOCATION	DIMENSIONS						ELEVATIONS	
	H	Bc	Rw	Lw	B	h	A	B
76 LT. FROM STA. 118+379	4.50	15.00	8.00	21.00	18.00	2.50	272	269.5
66 LT. FROM STA. 118+725	5.80	20.00	14.00	13.00	34.00	2.50	274	269.2
63 LT. FROM STA. 120+114	6.50	17.00	9.00	22.00	20.00	2.50	286	280.5
85 LT. FROM STA. 120+930	4.00	10.00	10.00	8.00	12.00	2.00	305	302.0
85 LT. FROM STA. 121+095	3.50	9.00	8.00	6.00	12.00	2.00	304	301.5
89 RT. FROM STA. 129+095	4.00	5.00	13.50	10.50	13.00	1.50	236.5	233.5

說明：圖中尺寸均為公尺。

NOTE: ALL DIMENSIONS ARE IN METERS

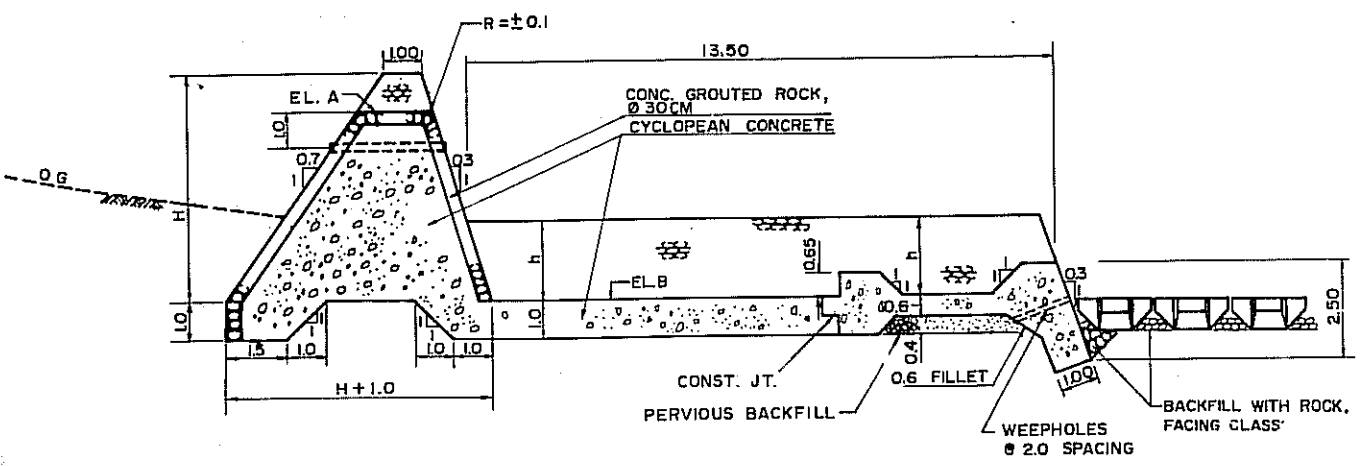

LONGITUDINAL SECTION

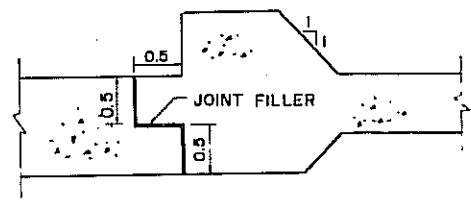

CONSTRUCTION JOINT

DRAINAGE STANDARD DETAILS

修正	REVISIONS
項目	ITEM
日期	DATE

交通部台灣區高速公路工程局
TAIWAN AREA FREEWAY CONSTRUCTION BUREAU
 中華民國
 台北高速公路 NORTH-SOUTH FREEWAY
 苗栗台中段 MIAOLI-TAICHUNG SECTION

囊砂壩 SOIL SAVING DAM

中華顧問工程司 CHINA ENGINEERING CONSULTANTS, INC.
 日期 DATE AUG. 74 比例 SCALE NTS 圖號 SHEET DT-26

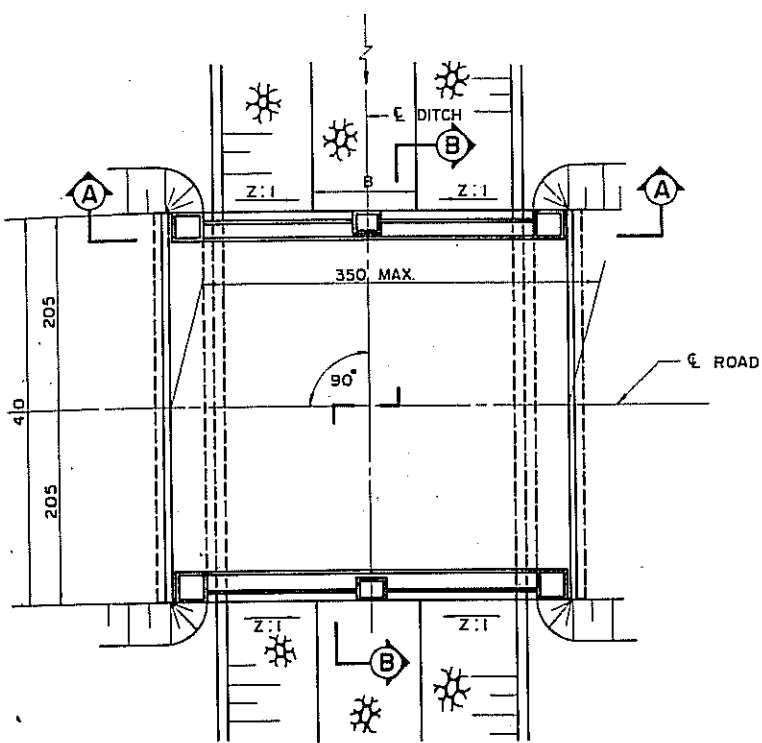

PLAN

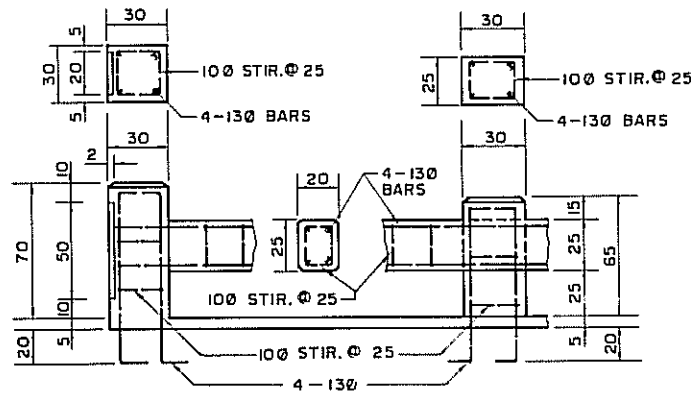

DETAIL OF RAILING

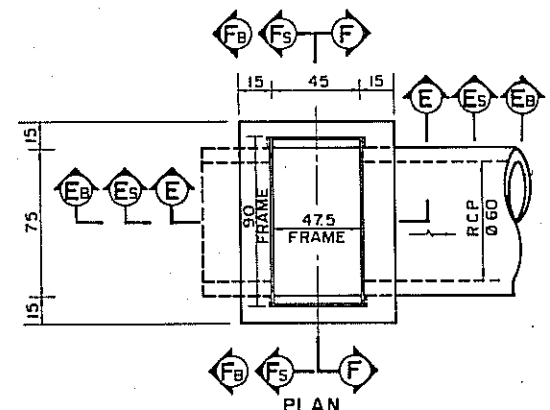

PLAN
排水井
DRAIN INLET
(GRATING OMITTED FOR CLARITY)

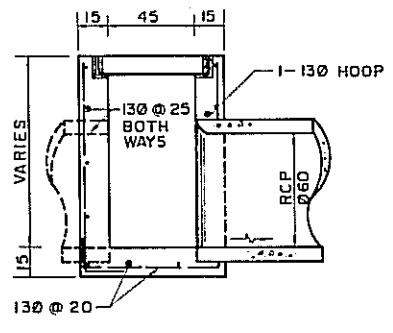

SECTION E - E

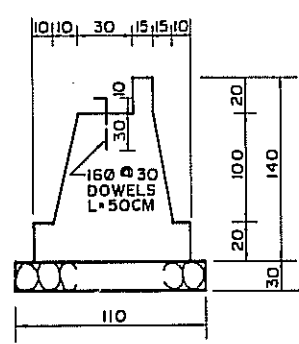

ABUTMENT

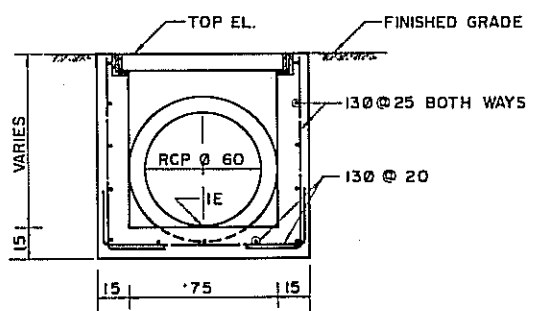

SECTION F - F

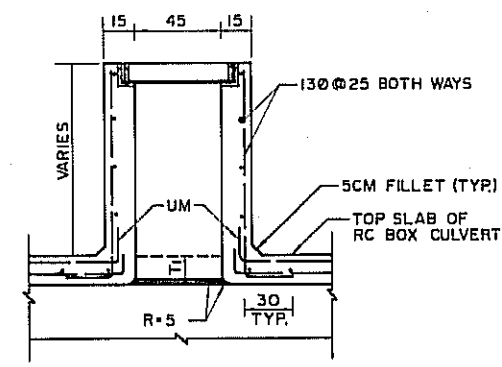

SECTION E_b-E_b

UM: INDICATES EXTENSION OF TOP SLAB
UPPER MAIN REINF. 30CM INTO DRAIN INLET WALL

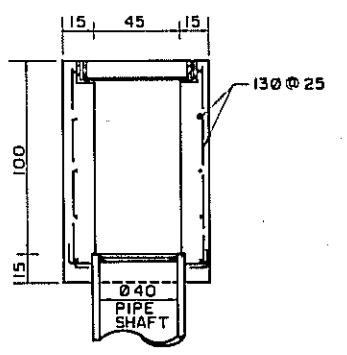

SECTION E_s-E_s

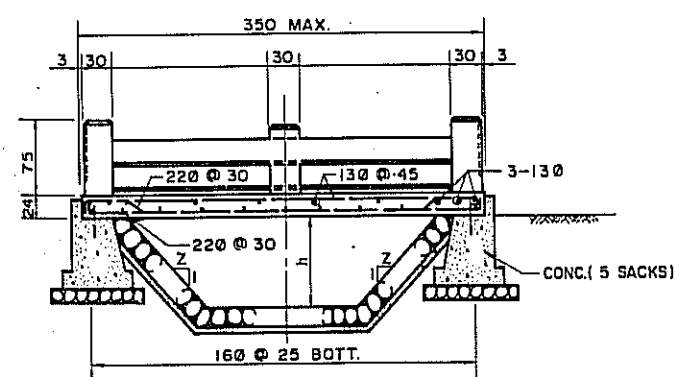

SECTION A - A

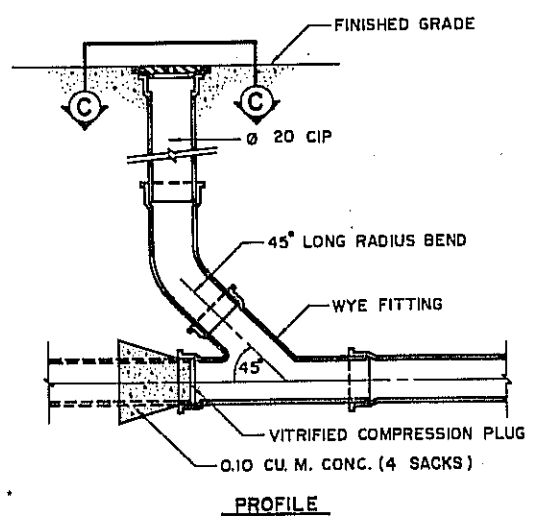

PROFILE

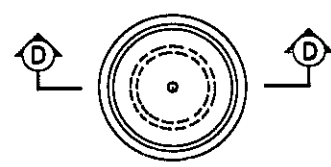

VIEW C - C

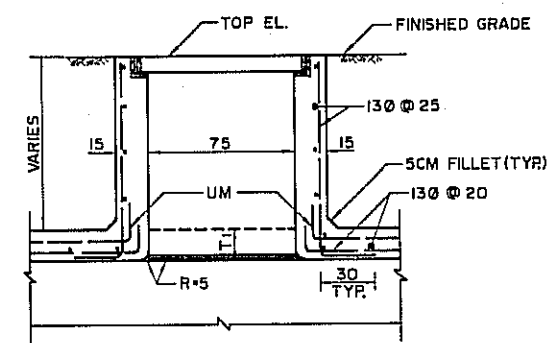

SECTION F_b-F_b

(DRAIN INLET CONNECTED WITH
BOX CULVERT)

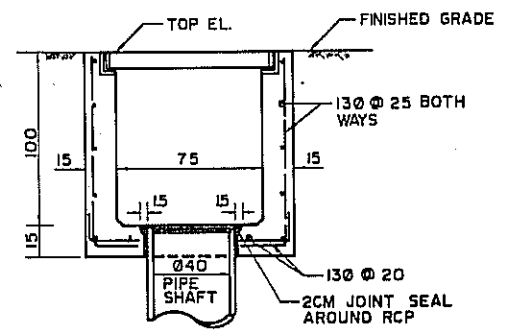

SECTION F_s-F_s

(DRAIN INLET WITH PIPE SHAFT)

FOR DETAIL OF GRATING & FRAME
OF DRAIN INLET - SEE SHEET DT-19

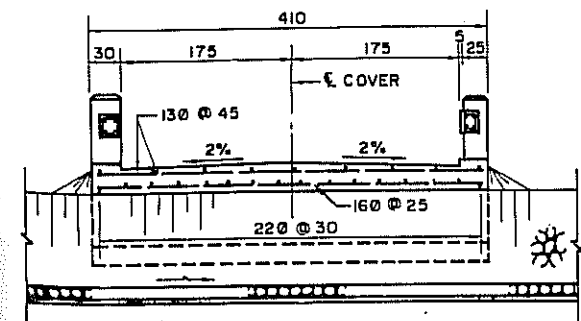

SECTION B - B

蓋版橋
DITCH COVER

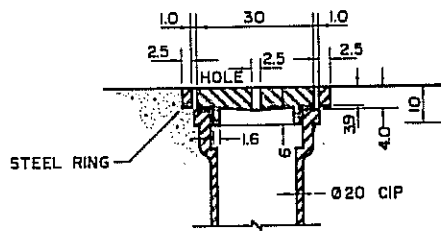

SECTION D - D

清潔孔
CLEANOUT
(FOR TOLL PLAZA ONLY)

DRAINAGE STANDARD DETAILS

修正 REVISIONS	項目 ITEM	日期 DATE

交通部台灣區高速公路工程局
TAIWAN AREA FREEWAY CONSTRUCTION BUREAU
中華民國 REPUBLIC OF CHINA
南北高速公路 NORTH-SOUTH FREEWAY
苗栗台中段 MIAOLI-TAICHUNG SECTION
蓋版橋及排水井 DITCH COVER & DRAIN INLET
中華顧問工程司 CHINA ENGINEERING CONSULTANTS, INC.
日期 DATE AUG. 74 比例 SCALE NTS 圖號 SHEET DT - 27

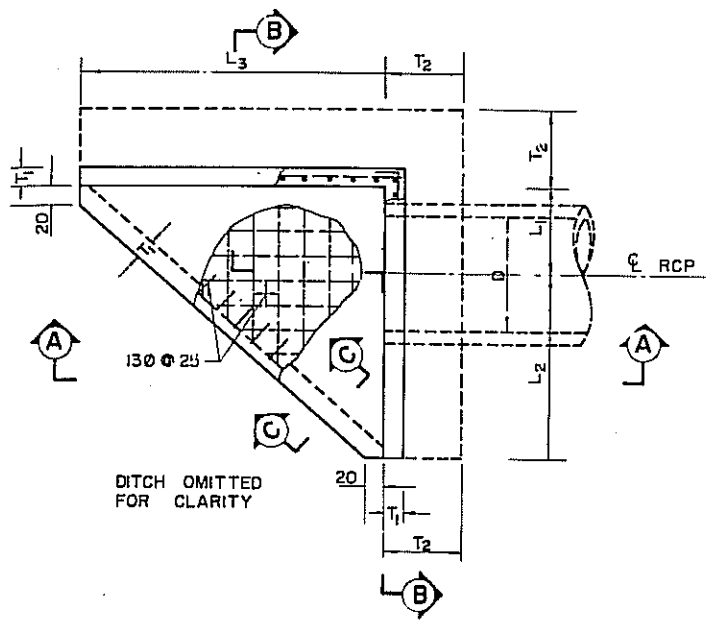

PLAN (NORMAL)

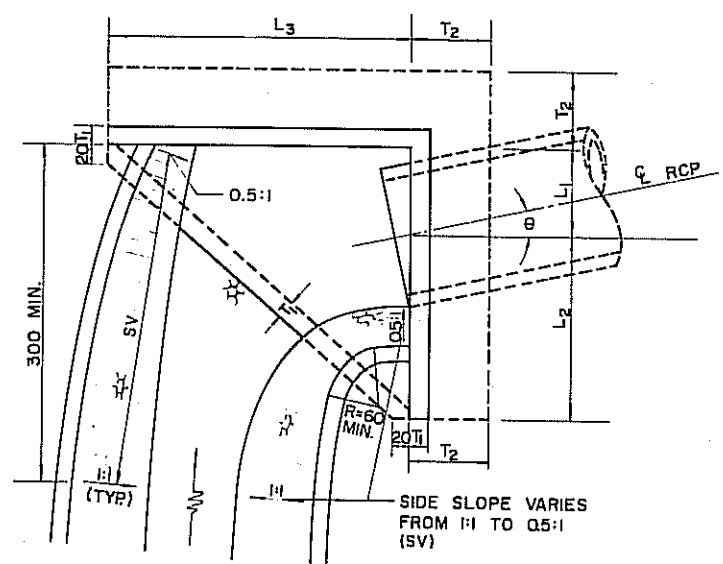

PLAN (SKEW $\theta < 15^\circ$)

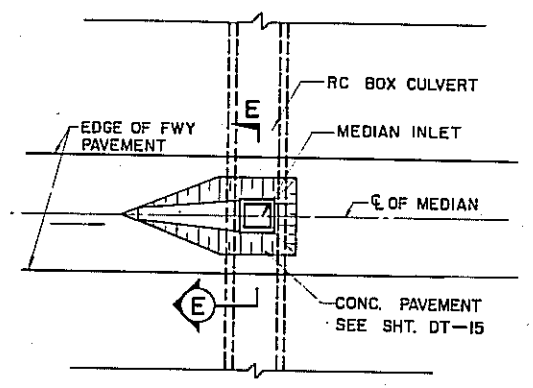

PLAN

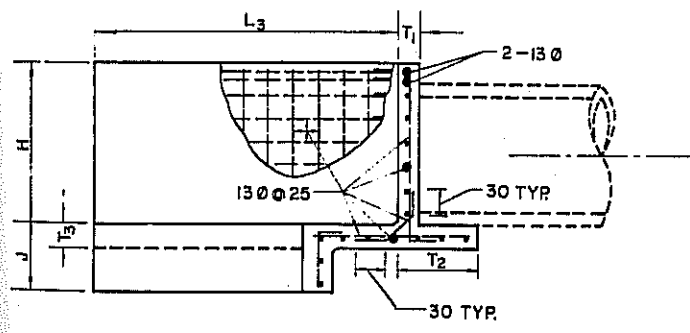

SECTION A-A

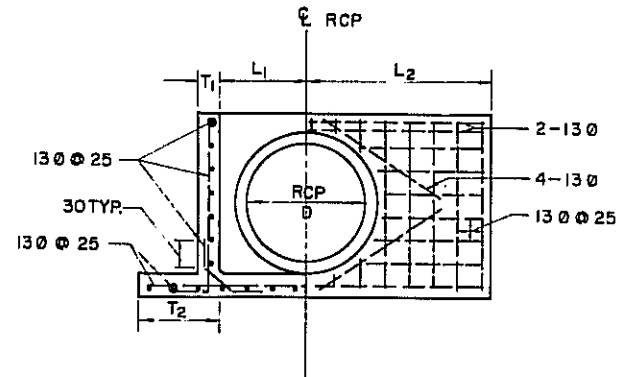

SECTION B-B

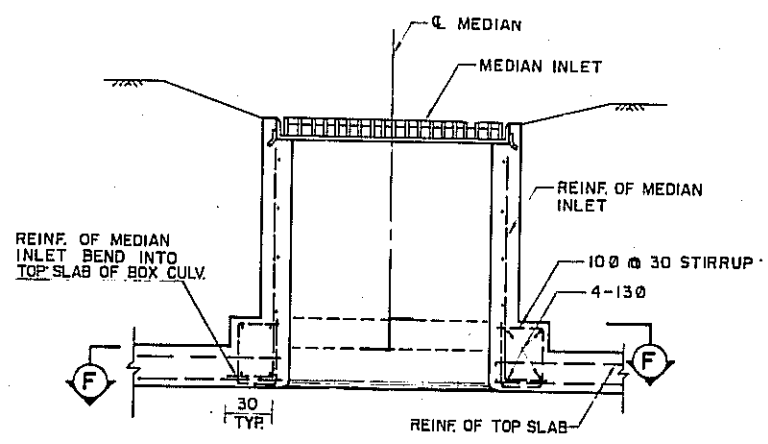

SECTION E-E
SEE SHT. NO. DT-15, 19 & 27 FOR REFERENCE

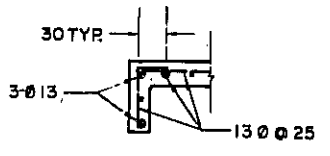

SECTION C-C

RCP Ø	T ₁	T ₂	T ₃	H	J	L ₁	L ₂	L ₃
60	15	55	20	100	60	50	120	180
80	15	55	20	120	60	65	140	220
100	20	60	25	145	60	75	170	270
120	20	60	25	165	70	90	190	310
150	20	60	30	205	70	105	230	380

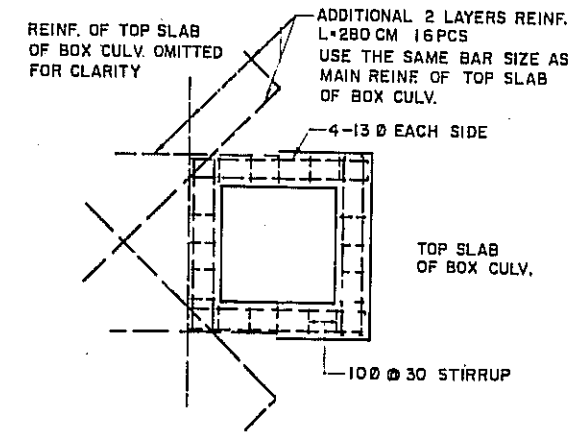

SECTION F-F

單管涵 L 型端牆
SINGLE RCP CULVERT ENDWALL, TYPE L

分漸帶進水井與箱涵連接
MEDIAN INLET CONNECT. WITH BOX CULVERT

DRAINAGE STANDARD DETAILS

修正	REVISIONS	項目	ITEM	日期	DATE

交通部台灣區高速公路工程局
TAIWAN AREA FREEWAY CONSTRUCTION BUREAU
中華民國
REPUBLIC OF CHINA
南北高速公路
NORTH-SOUTH FREEWAY
苗栗台中段
MIAOLI - TAICHUNG SECTION
管涵 L 型端牆 RCP CULVERT ENDWALL TYPE L
MED INLET CONNECT. WITH
分漸帶進水井與箱涵連接
BOX CULVERT
中華顧問工程司
CHINA ENGINEERING CONSULTANTS, INC.
日期 DATE AUG 74 比例 SCALE NTS 圖號 SHEET DT-28

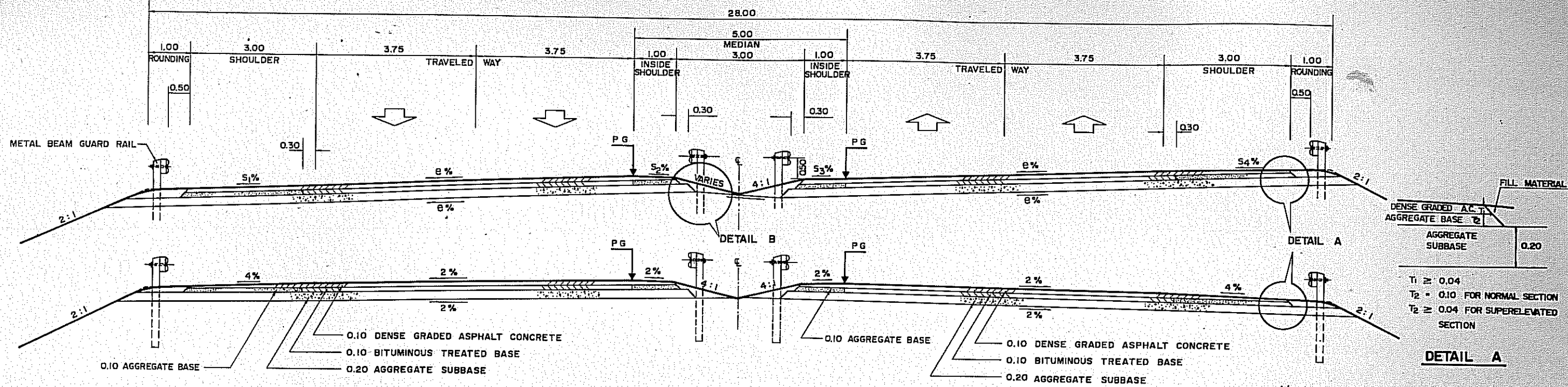

四車道高速公路標準及超高斷面
4-LANE FREEWAY NORMAL & SUPERELEVATED SECTION

說明：
中央分隔帶兩側設護欄，填土高度≥3公尺時，
外路肩設護欄。

NOTE:
THE OUTER GUARD RAIL USED FOR EMBANKMENT
HEIGHT ≥ 3.00
METAL BEAM GUARD RAILS IN FWY. MEDIAN ARE
TYP.

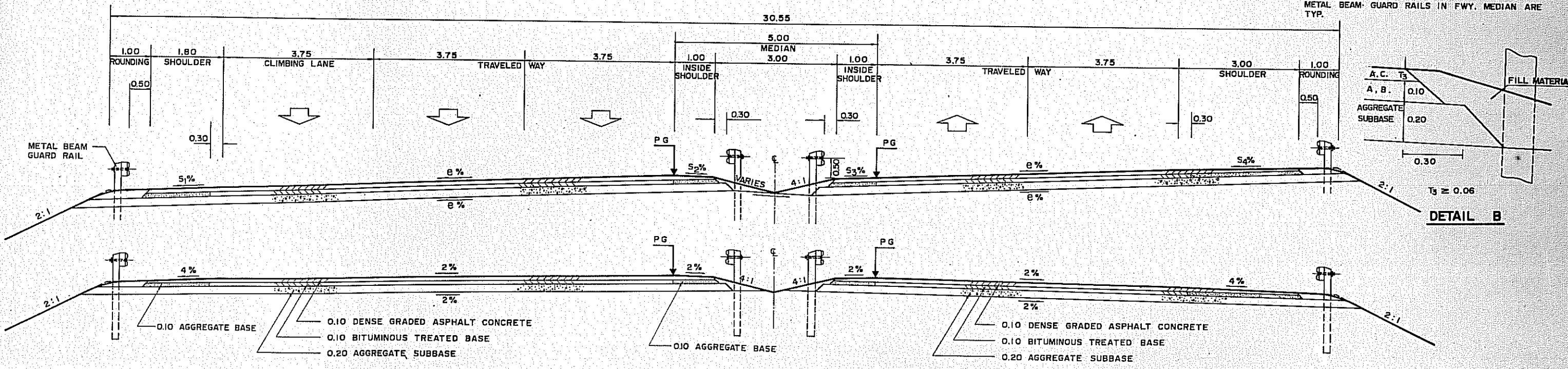

四車道高速公路附爬坡車道標準及超高斷面
4-LANE FREEWAY WITH CLIMBING LANE NORMAL & SUPERELEVATED SECTION

TABLE: SHOULDER CROSS SLOPE

e	S ₁	S ₂	S ₃	S ₄
2%	4%	-2%	2%	-2%
3%	4%	-1%	3%	1%
4%	4%	0%	4%	2%
5%	5%	1%	5%	3%

PROJECT 60

修正	REVISIONS	項目	ITEM	日期	DATE

交通部台灣區高速公路工程局
TAIWAN AREA FREEWAY CONSTRUCTION BUREAU
中華民國
REPUBLIC OF CHINA
南北高速公路
NORTH-SOUTH FREEWAY
苗栗台中段
MIAOLI-TAICHUNG SECTION
標準斷面
TYPICAL SECTIONS
FREEWAY
中華顧問工程司
CHINA ENGINEERING CONSULTANTS, INC.
日期 DATE AUG. 74 比例 SCALE 1:50 圖號 SHEET F-1

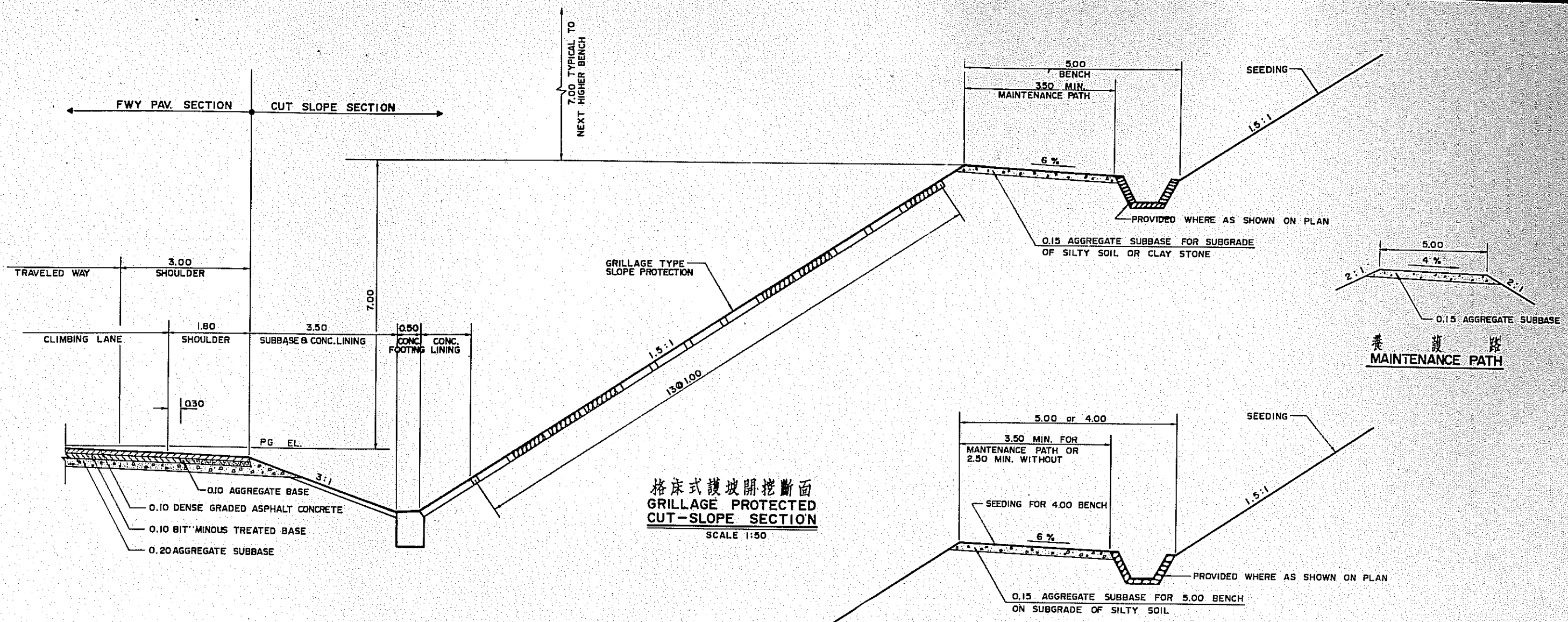

格床式護坡開挖斷面
GRILLAGE PROTECTED
CUT-SLOPE SECTION
SCALE 1:50

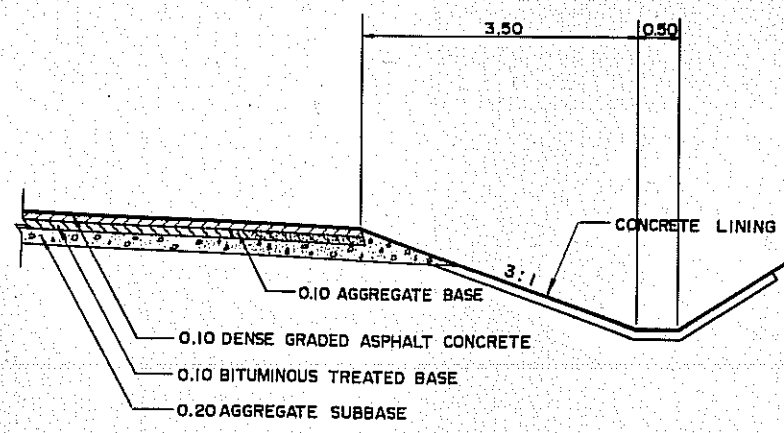

種草開挖斷面
SEEDING CUT-SLOPE SECTION
SCALE 1:50

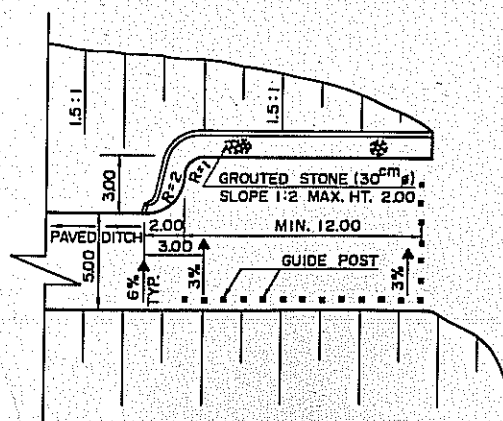

迴頭廣場詳圖
TURNOUTS DETAIL
SCALE 1:200

說明:

- 自 125+310 至 126+020, 路面至第一層平台間如圖所示設格床式護坡, 第一層平台以上開挖邊坡需按標準種草。
- 挖方平台標準寬度為 4 公尺, 平面圖指定挖方平台兼作養護通行道路時平台寬度為 5 公尺。
- 格床式護坡種草及排水設施詳圖參閱 GT-1 及 DT-20

NOTES:

- PROVIDE GRILLAGE PROTECTION FOR FWY FROM STA. 125+310 TO STA. 126+020, ON SLOPES AT FIRST LOWER LEVEL, BEYOND THAT SEEDING SHALL BE APPLIED.
- 4.00 BENCH TYPICAL FOR CUT SECTION, AND WHERE MAINTENANCE PATH IS SHOWN ON PLAN, 5.00 BENCH SHALL BE PROVIDED.
- FOR GRILLAGE, SEEDING AND DRAINAGE DETAILS SEE SHT GT-1 & DT-20

PROJECT 60

修正	REVISIONS	項目	ITEM	日期	DATE

交通部台灣區高速公路工程局
TAIWAN AREA FREEWAY CONSTRUCTION BUREAU
中華民國
REPUBLIC OF CHINA
南北高速公路
NORTH-SOUTH FREEWAY
苗栗台中段
MIAOLI-TAICHUNG SECTION
標準斷面
TYPICAL SECTIONS
FREEWAY
中華顧問工程司
CHINA ENGINEERING CONSULTANTS, INC.
日期 DATE AUG. 74 比例 SCALE AS SHOWN 圖號 SHEET F-2

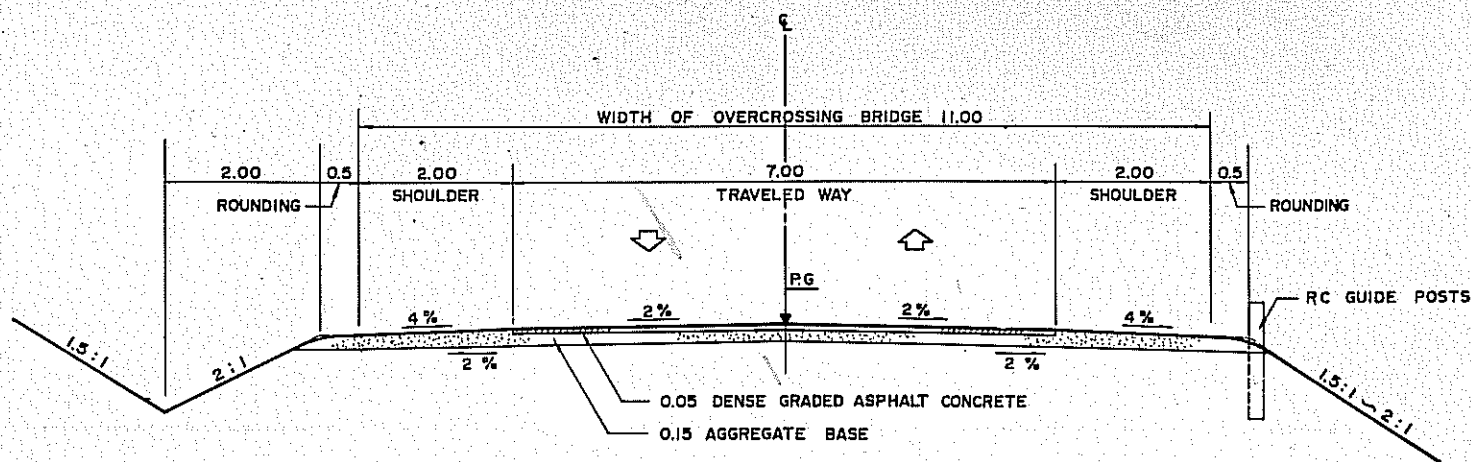

雙車道標準斷面
2 - LANE NORMAL SECTION
SCALE 1:50

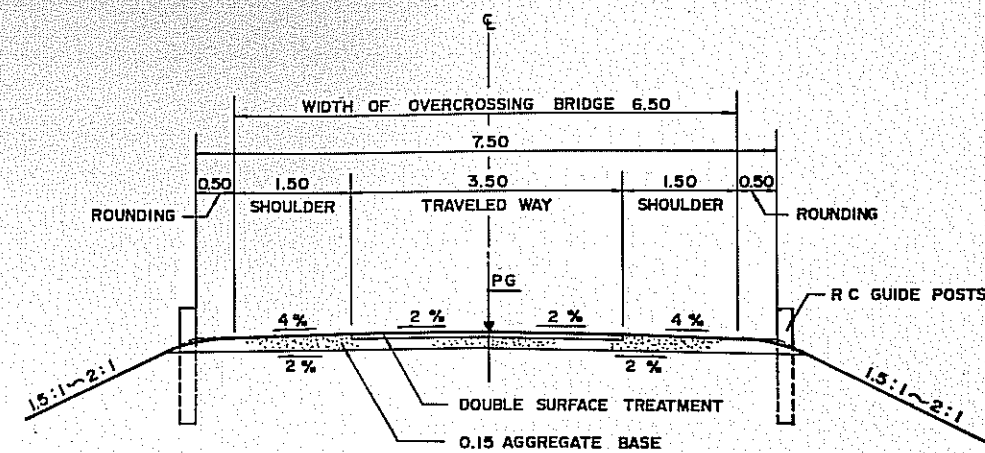

單車道標準斷面
1 - LANE NORMAL SECTION
SCALE 1:50

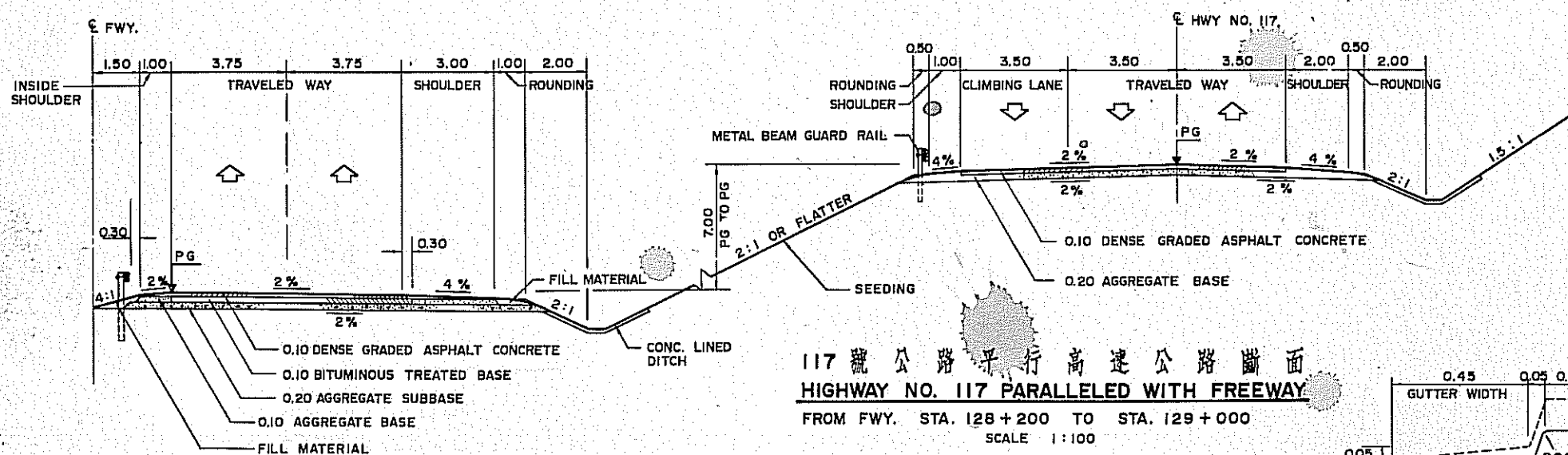

117 號公路平行高速公路斷面
HIGHWAY NO. 117 PARALLELED WITH FREEWAY
FROM FWY. STA. 128+200 TO STA. 129+000
SCALE 1:100

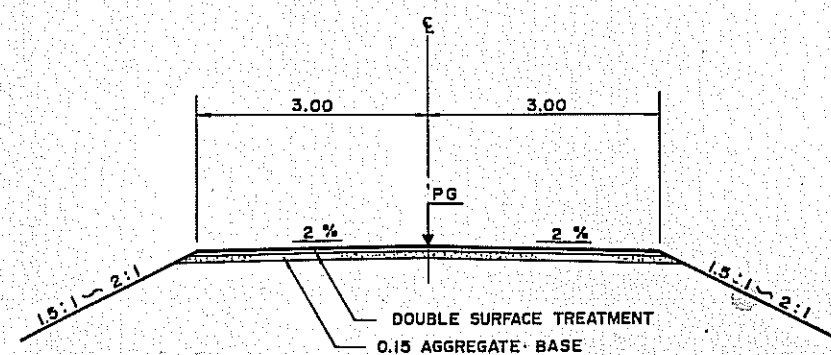

聯接道路標準斷面
NORMAL SECTION OF FRONTAGE ROAD
SCALE 1:50

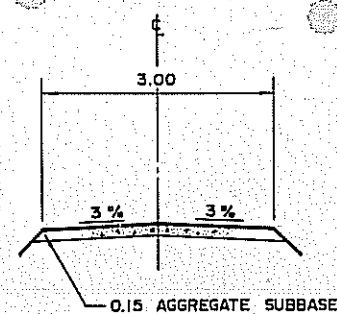

農路標準斷面
FIELD PATH
SCALE 1:10

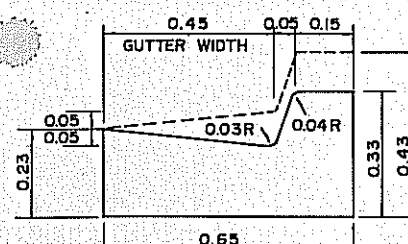

B 型緣石
TYPE B CURB
SCALE 1:10

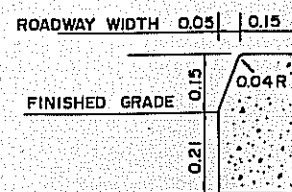

A 型緣石
TYPE A CURB
SCALE 1:10

說明:

- 117 號公路改線部份需設置護欄。跨越橋引道 (參閱圖號 FT-4 及 FT-6) 設置護欄。
- 雙車道, 單車道, 及聯接道路:
 - (1) 填土邊坡為 1.5:1, 填土高度 ≥ 5 公尺時, 邊坡為 2:1, 邊坡漸變長度為 50 公尺。
 - (2) 填土高度 ≥ 3 公尺時需設置 RC 護欄。
 - (3) 超高漸變以路線中心為固定軸轉動。
 - (4) 超高及漸變長度請參閱平面圖。
 - (5) 基層橫坡需與車道橫坡相同。
- 水田地區, 農路路面應較現地面高 0.50 公尺。

NOTES:

- METAL BEAM GUARD RAIL USED ALONG THE RELOCATED HWY 117 AND APPROACHES OF OVERCROSSING BRIDGE AS SHOWN ON SHT. FT-4 & FT-6.
- FOR 2 OR 1-LANE HWY AND FRONTAGE ROAD:
 - (1) FILL SLOPE SHALL BE 1.5:1 AND FLATTENED TO 2:1 FOR EMBANKMENT HEIGHT ≥ 5.00 M WITH 50 M TRANSITION OF CHANGING SLOPE.
 - (2) RC GUIDE POSTS USED FOR EMBANKMENT HEIGHT ≥ 3.00 M.
 - (3) THE SUPERELEVATION SECTION IS ATTAINED TO ROTATE THE PAV. ABOUT THE ϵ .
 - (4) THE SUPERELEVATION RATE AND TRANSITION IS SHOWN ON THE PLAN.
 - (5) THE SUBGRADE CROSS SLOPE IS OF SAME GRADE AS THAT OF TRAVELED WAY.
- FIELD PATH SHALL BE 0.50M HIGHER THAN EXISTING GROUND LINE IN PADDY FIELD.

PROJECT 60

修正	REVISIONS	交通部台灣區高速公路工程局		
項目	ITEM	日期	DATE	TAIWAN AREA FREEWAY CONSTRUCTION BUREAU
				中華民國
				REPUBLIC OF CHINA
				南北高速公路
				NORTH-SOUTH FREEWAY
				苗栗台中段
				MIAOLI-TAICHUNG SECTION
				標準斷面
				TYPICAL SECTIONS
				HWY. & ROAD
				中華顧問工程司
				CHINA ENGINEERING CONSULTANTS, INC.
				日期 DATE AUG '74
				比例 SCALE AS SHOWN
				圖號 SHEET F-5

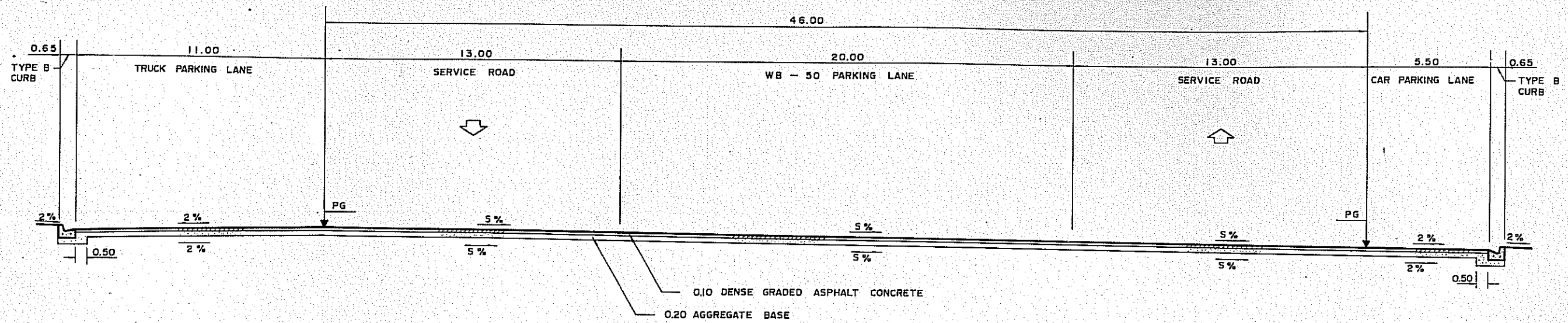

停車場及道路標準斷面
PARKING LOT & SERVICE ROAD NORMAL SECTION

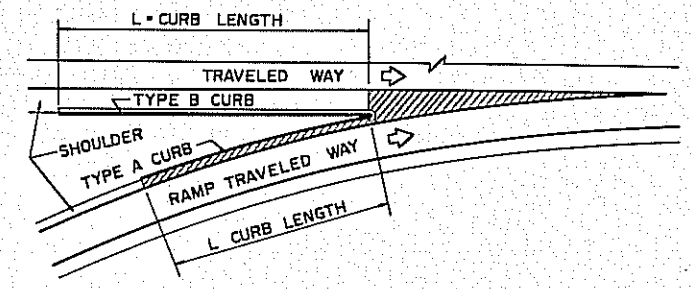
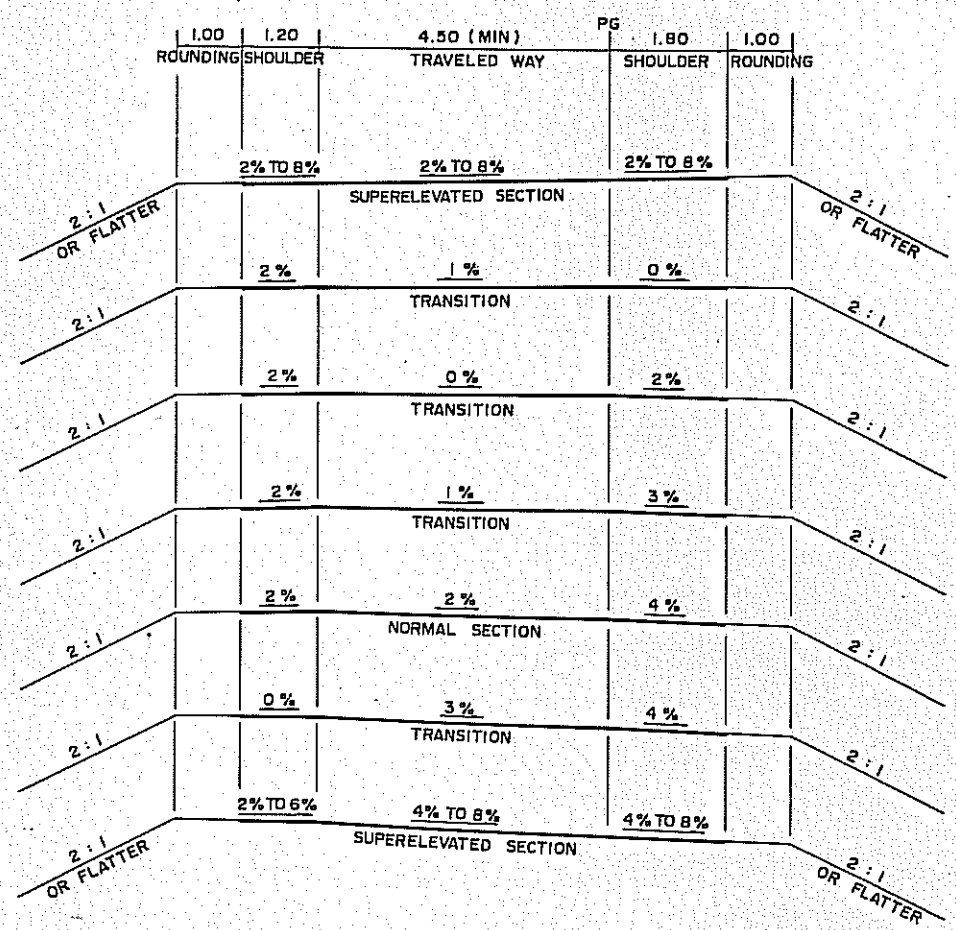

ENTRANCE NOSE

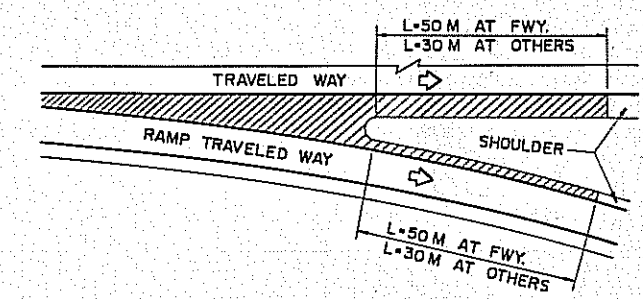

EXIT NOSE

PAVEMENT TREATMENT AT RAMP TERMINALS
THE SHADED AREAS SHALL HAVE RAMP TRAVELED WAY PAVEMENT

匝道超高設置橫斷面
(最大超高漸變率：每10公尺1.65%)
SECTIONAL VIEW FOR RAMP SUPERELEVATION TRANSITION
(MAX. GRADE CHANGE OF SUPERELEVATION TRANSITION=1.65% PER 10.00 M)

- 說明：
- 停車場路面橫坡之變化請參閱詳細平面圖。
 - 所有尺寸除另有註明者外均以公尺計。
- NOTES:
- PAVEMENT CROSS SLOPE OF PARKING LOT (5%) ARE VARIOUS, REFER TO PLAN DETAILS
 - ALL DIMENSIONS ARE IN METERS UNLESS OTHERWISE NOTED

修正 REVISIONS		PROJECT 60	
項目 ITEM	日期 DATE	交通部台灣區高速公路工程局 TAIWAN AREA FREEWAY CONSTRUCTION BUREAU 中華民國 南北高速公路 NORTH-SOUTH FREEWAY 苗栗台中段 MIAOLI-TAICHUNG SECTION	
		標準斷面 TYPICAL SECTIONS REST AREA	
		中華顧問工程司 CHINA ENGINEERING CONSULTANTS, INC. 日期 DATE AUG. '74 比例 SCALE NONE 圖號 SHEET F-7	

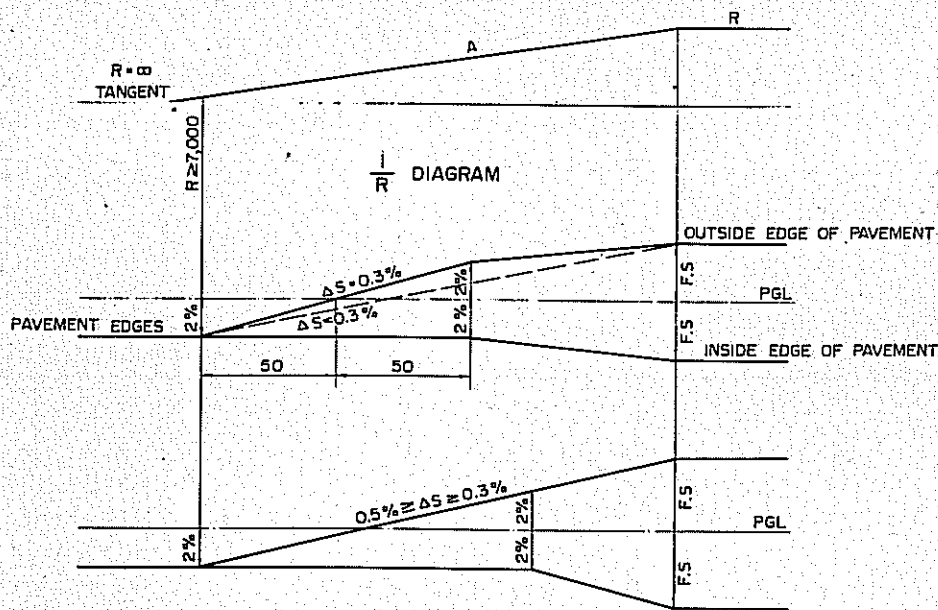

SUPERELEVATION DIAGRAM

直線—緩和曲線—圓曲線
TANGENT TO CURVE CONNECTED BY CLOTHOID

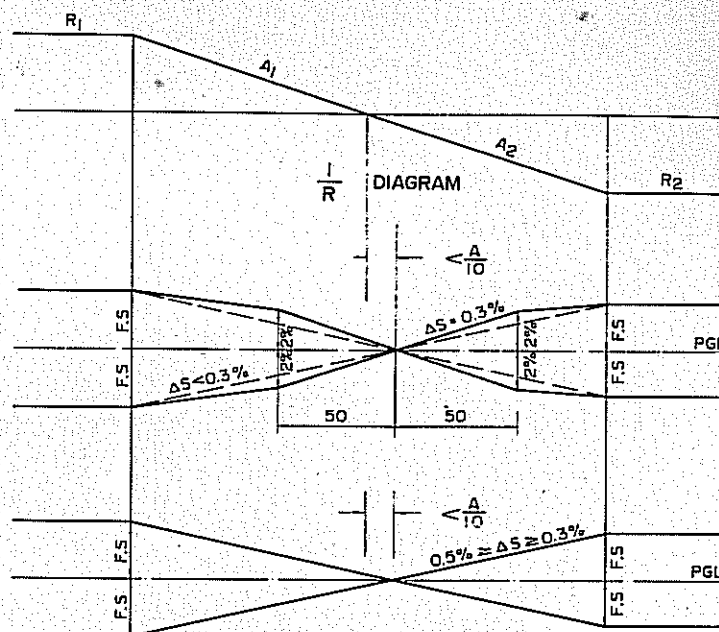

SUPERELEVATION DIAGRAM

圓曲線—反向緩和曲線—圓曲線
REVERSE CURVE CONNECTED BY CLOTHOIDS

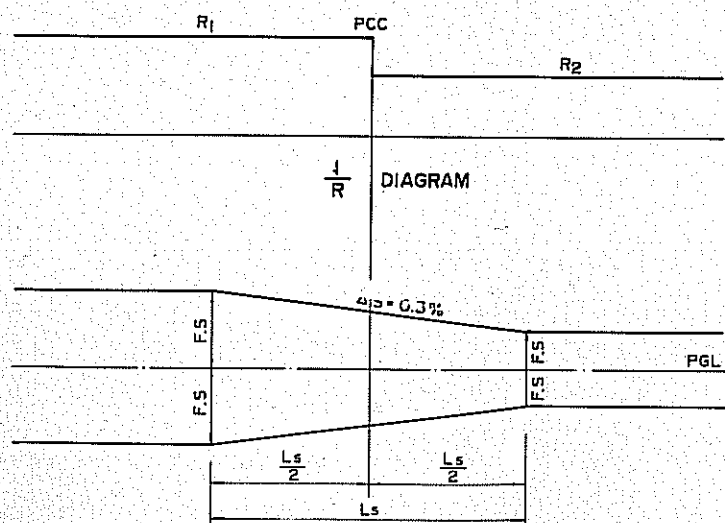

SUPERELEVATION DIAGRAM

複曲線
COMPOUND CURVE

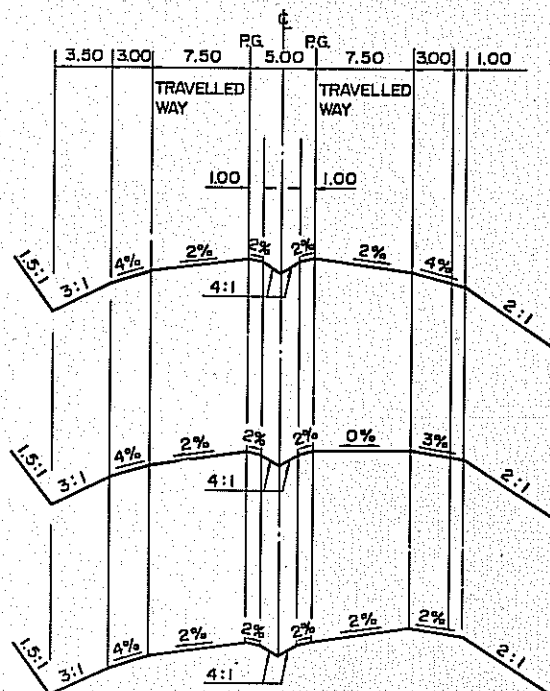

2% 超高設置橫斷面
SECTIONAL VIEW FOR REVERSED CROWN TRANSITION

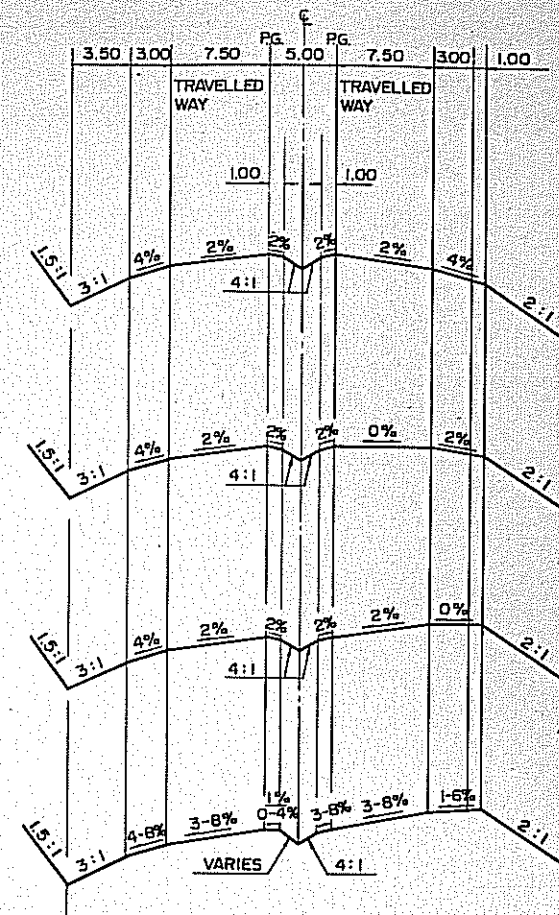

> 2% 超高設置橫斷面
SECTIONAL VIEW FOR SUPERELEVATION TRANSITION

說明:

- 所有尺寸以公尺計。
- R — 圓曲線半徑。
- A — 緩和曲線。
- ΔS — 超高設置百分比。

NOTES:

- ALL DIMENSIONS ARE IN METERS.
- R — RADIUS OF CIRCULAR CURVE.
- A — PARAMETER OF CLOTHOID.
- ΔS — SLOPE OF OUTER EDGE OF PAVEMENT WITH RESPECT TO PGL

高速公路超高設置
SUPERELEVATION TRANSITION FOR FREEWAY

PROJECT 60

修正	REVISIONS	交通部台灣區高速公路工程局
項目	ITEM 日期 DATE	TAIWAN AREA FREEWAY CONSTRUCTION BUREAU
		中華民國
		REPUBLIC OF CHINA
		南北高速公路
		NORTH-SOUTH FREEWAY
		苗栗台中段
		MIAOLI-TAICHUNG SECTION
		超高設置圖
		SUPERELEVATION
		TRANSITION DIAGRAM
		中華顧問工程司
		CHINA ENGINEERING CONSULTANTS, INC.
		DATE AUG. 74 比例 SCALE NONE 圖號 APPENDIX F-16

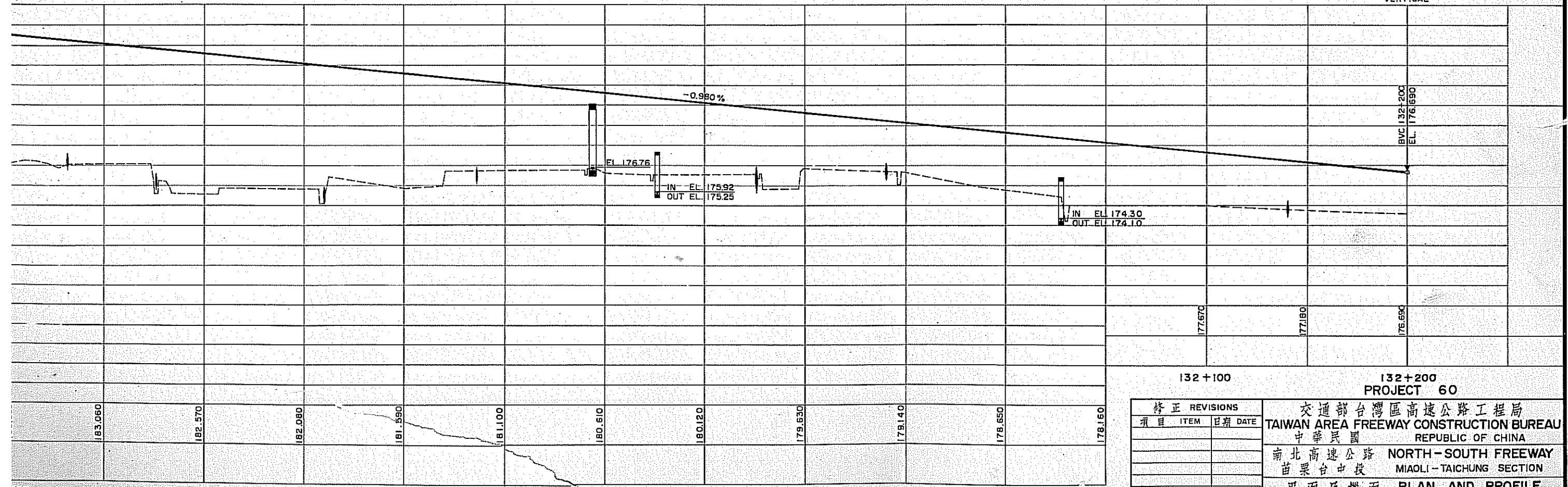
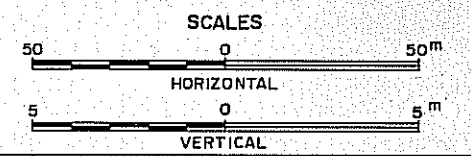
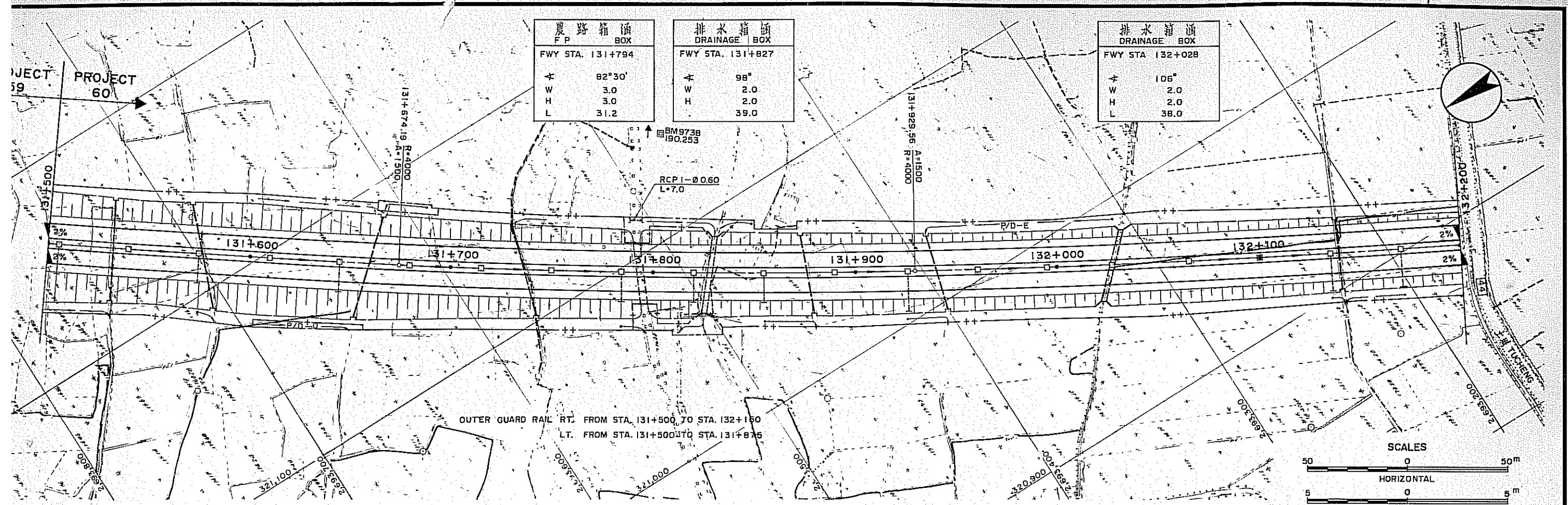

修正 REVISIONS			交通部台灣區高速公路工程局 TAIWAN AREA FREEWAY CONSTRUCTION BUREAU 中華民國 REPUBLIC OF CHINA 南北高速公路 NORTH-SOUTH FREEWAY 苗栗台中段 MIAOLI-TAICHUNG SECTION 平面及縱面 PLAN AND PROFILE STA. 131+500 TO STA. 132+200 中華顧問工程司 CHINA ENGINEERING CONSULTANTS, INC. 日期 DATE AUG. '74 比例 SCALE AS SHOWN 圖號 SHEET F-21	
項目 ITEM	日期 DATE			

560 131+600 131+700 131+800 131+900 132+000

排水箱涵 DRAINAGE BOX	
FWY STA	132+203
+	90°
W	4.0
H	3.0
L	33.5

HWY 44 單車道跨越橋 1-LANE O/C	
FWY STA	132+246.82
HWY STA.	0+334.79
+	73°22'29"
W	6.5
H	>5.0
L	49.8

排水箱涵 DRAINAGE BOX	
FWY STA.	132+555
+	90°
W	3.5
H	3.0
L	32.7

排水箱涵 DRAINAGE BOX	
FWY STA.	132+823
+	90°
W	2.0
H	2.0
L	49.5

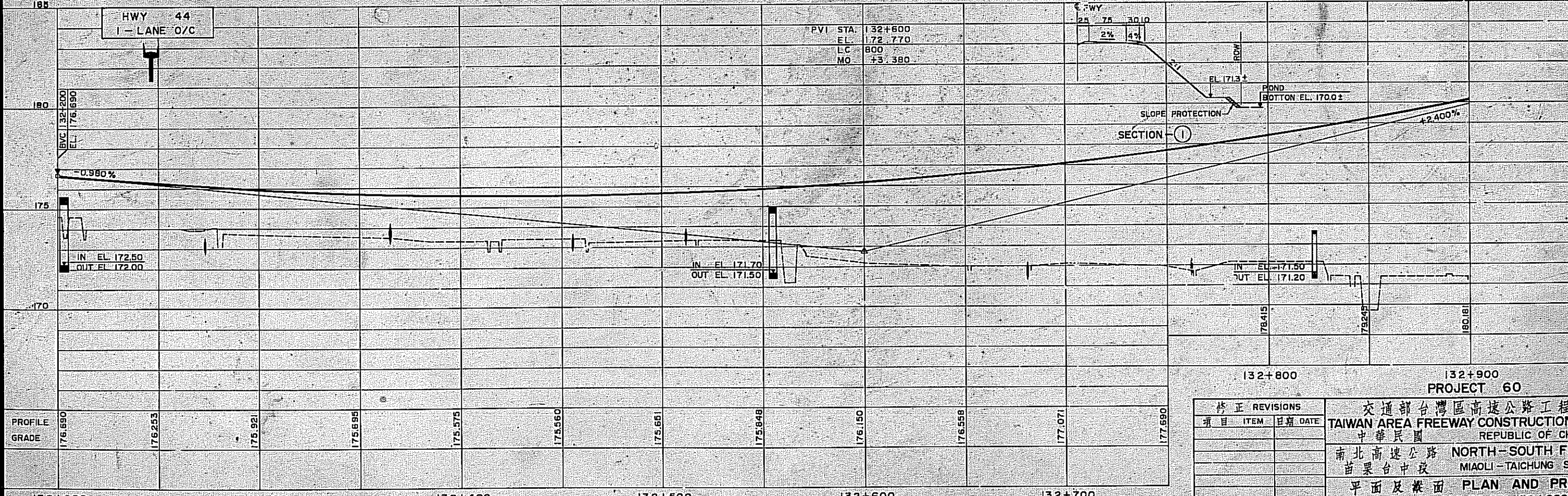
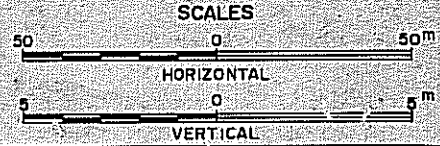
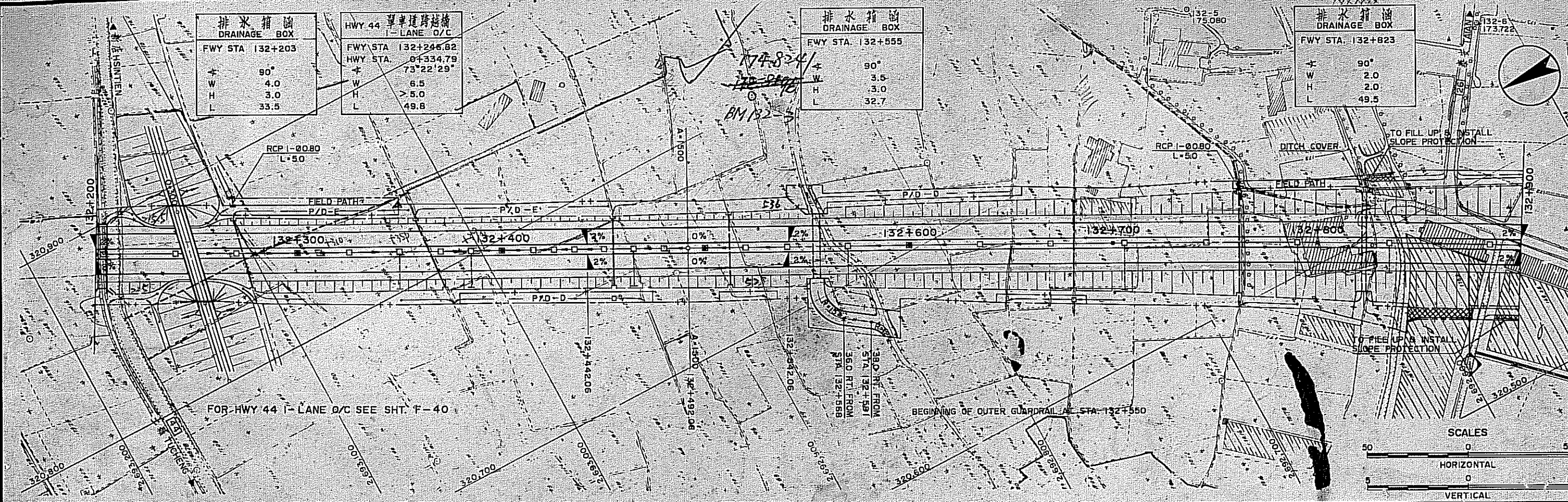

修正 REVISIONS	
項目 ITEM	日期 DATE

交通部台灣區高速公路工程局
TAIWAN AREA FREEWAY CONSTRUCTION BUR
中華民國 REPUBLIC OF CHINA
南北高速公路 NORTH-SOUTH FREEW
苗栗台中段 MIAOLI-TAICHUNG SECTION
平面及縱面 PLAN AND PROFILE
STA. 132+200 TO STA. 132+900
中華顧問工程司 CHINA ENGINEERING CONSULTANTS
日期 DATE: AUG. '74 比例 SCALE: AS SHOWN 圖號 SHEET: 3

132+800

HWY 26 雙車道單越橋 2-LANE U/C	排水箱涵 DRAINAGE BOX
FWY STA. 132+959.29	FWY STA. 132+996.50
HWY 26 STA. 0+198.26	W 71'
W 75'32'	H 3x5.0
H 2x11.5	H 3.0
L > 4.6	L 71.5
L 17.8	

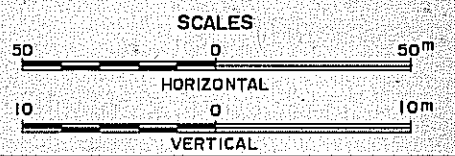
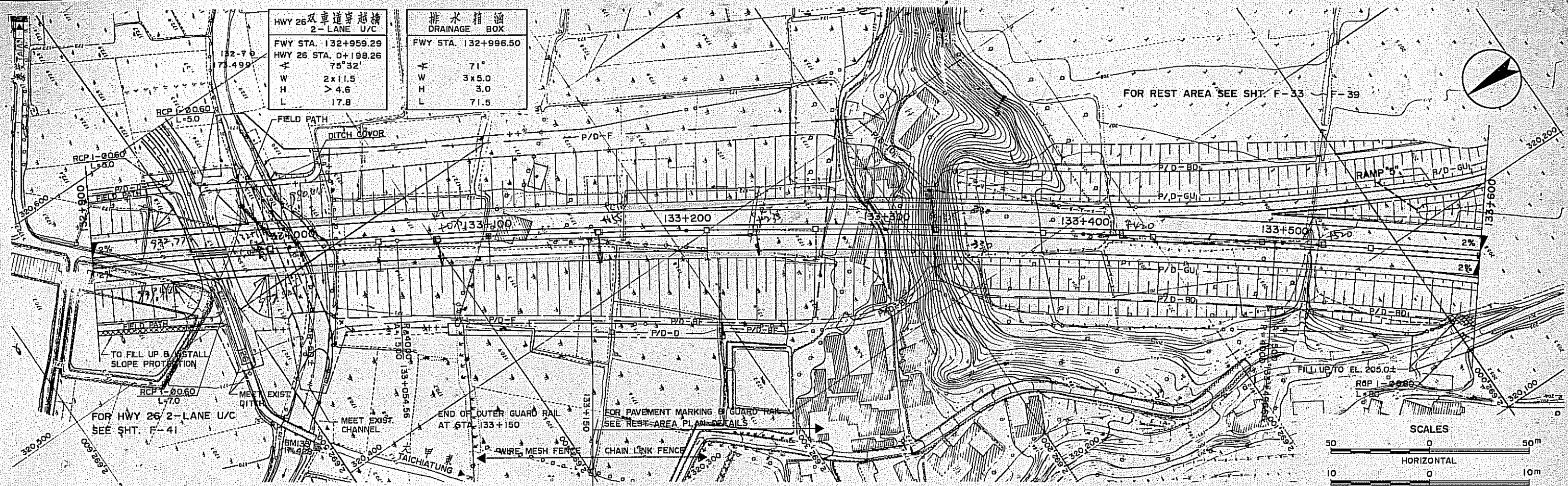

修正 REVISIONS		交通部台灣區高速公路工程局 TAIWAN AREA FREEWAY CONSTRUCTION BUREAU 中華民國 南北高速公路 NORTH-SOUTH FREEWAY 苗栗台中段 MIAOLI-TAICHUNG SECTION 平面及縱面 PLAN AND PROFILE STA. 132+900 TO STA. 133+600 中華顧問工程司 CHINA ENGINEERING CONSULTANTS, INC. DATE AUG. '74 SCALE AS SHOWN SHEET F-23
項目 ITEM	日期 DATE	

新 158+600

双車道中央溝
FLUME & 2-LANE O/C
FWY STA. 133+680.50
RAMP 1" STA. 0+427.98
A 81°49'54"
W 11.0
H > 5.0
L 74.0

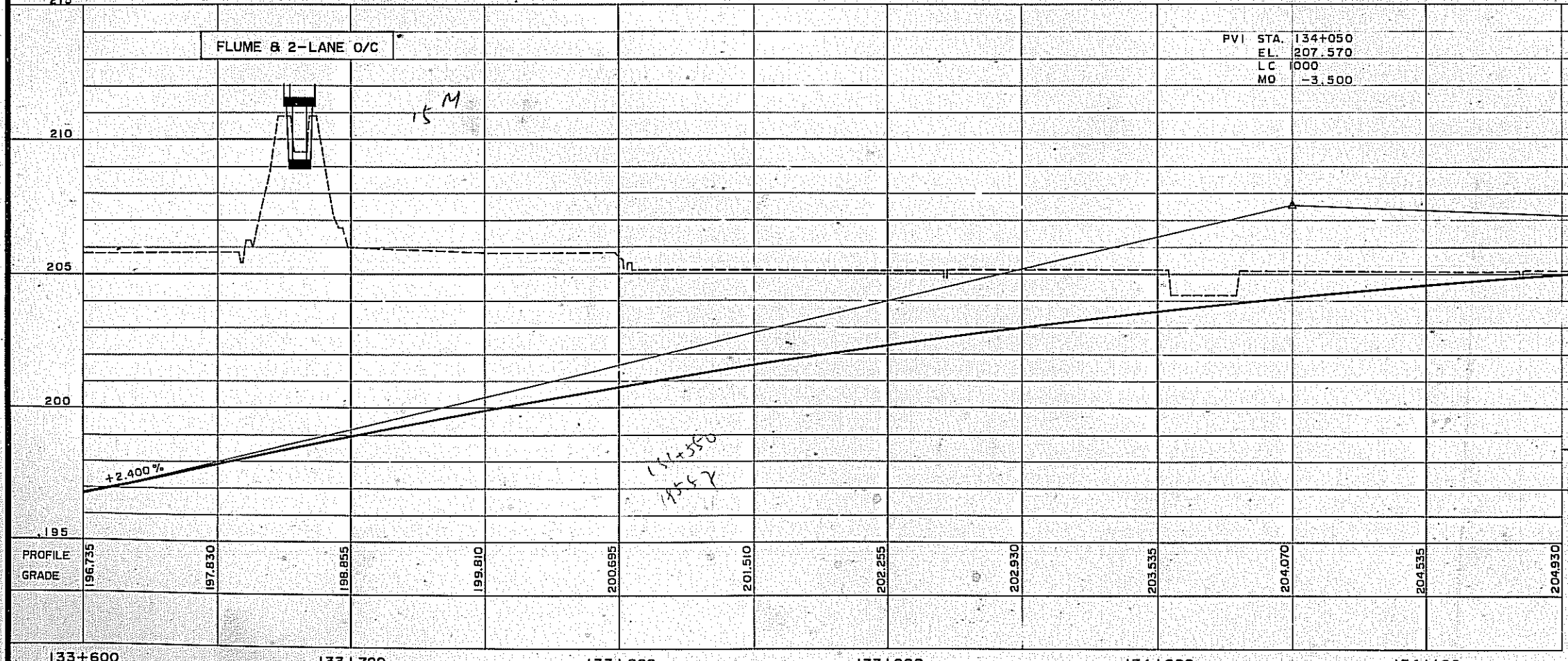
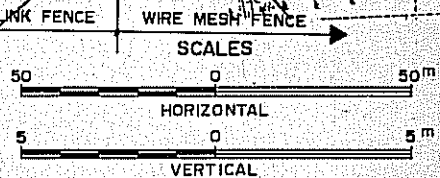
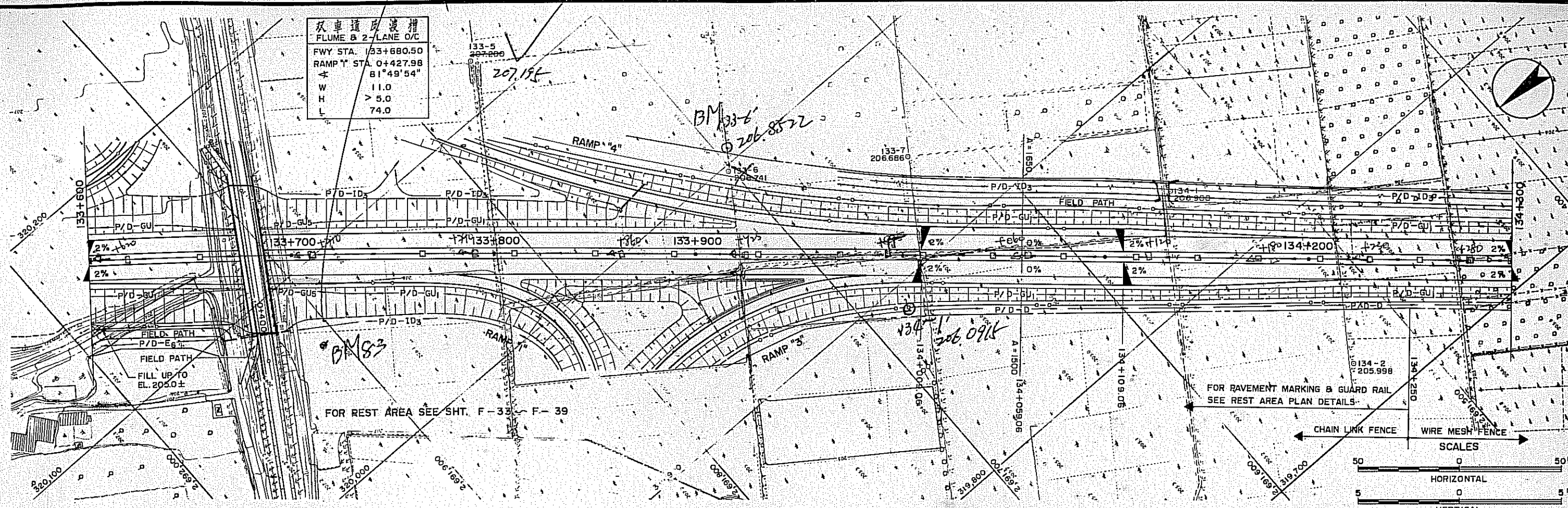

PVI STA. 134+050
EL. 207.570
LC 000
MO -3.500

修正 REVISIONS		
項目 ITEM	日期 DATE	

交通部台灣區高速公路工程局
TAIWAN AREA FREEWAY CONSTRUCTION BUREAU
中華民國
台北高速公路 NORTH-SOUTH FREEWAY
苗栗台中段 MIAOLI-TAICHUNG SECTION
平面及縱面 PLAN AND PROFILE
STA. 133+600 TO STA. 134+300
中華顧問工程司 CHINA ENGINEERING CONSULTANTS, INC.
日期 DATE AUG. '74 比例 SCALE AS SHOWN 圖號 SHEET F-24

49/1/60

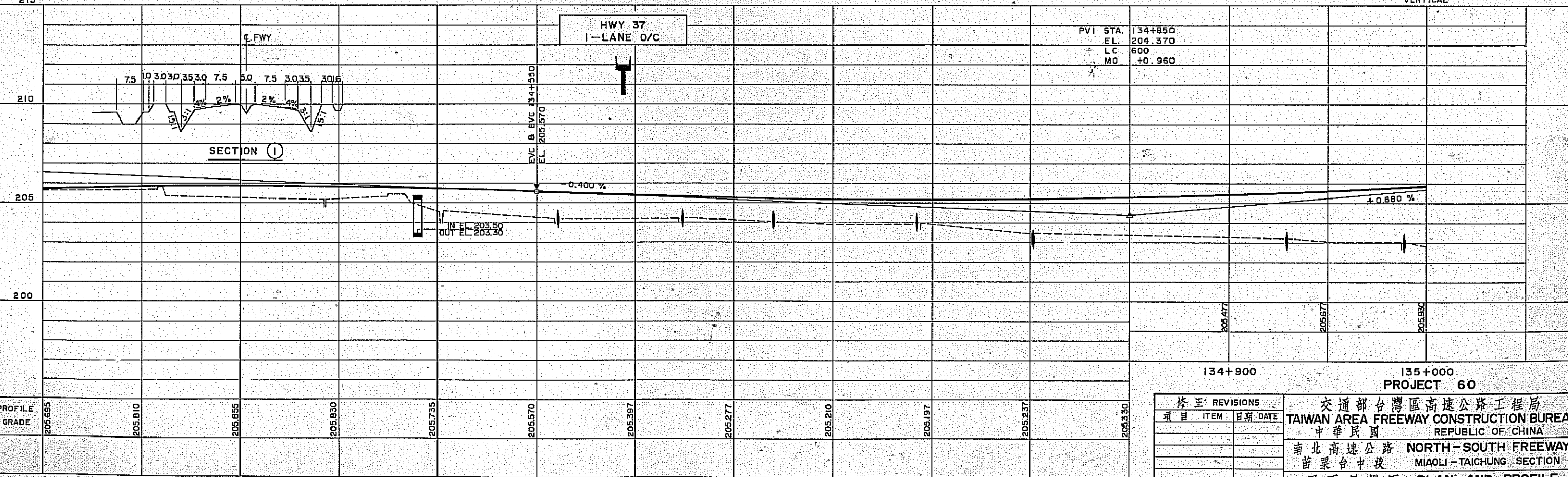
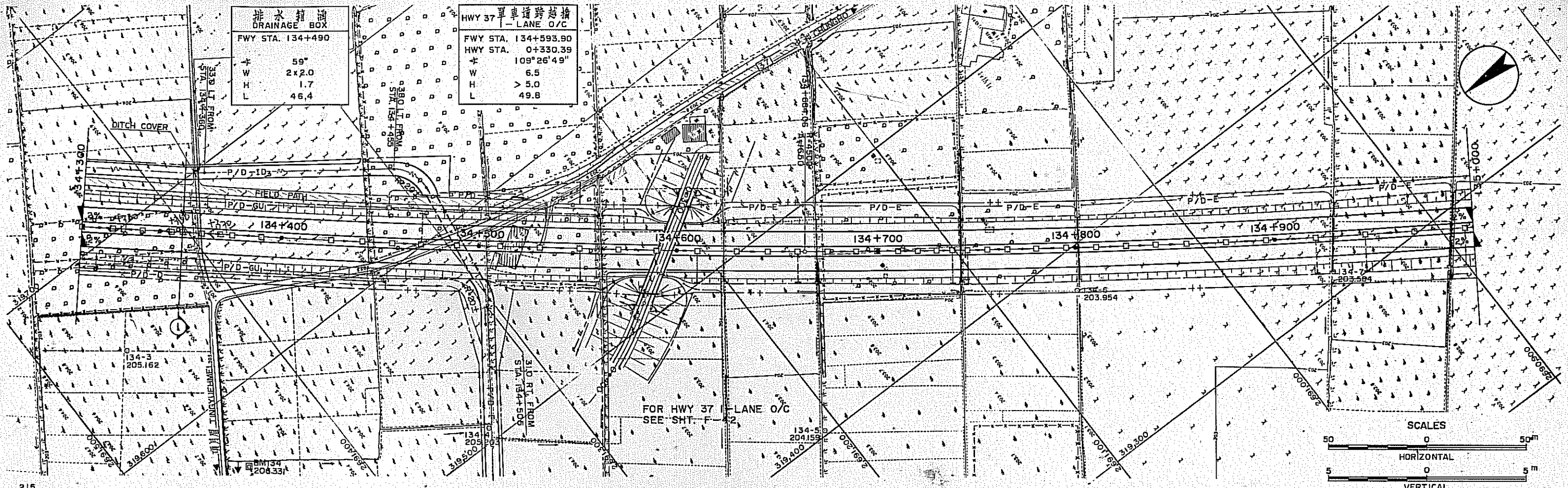

修正 REVISIONS		交通部台灣區高速公路工程局 TAIWAN AREA FREEWAY CONSTRUCTION BUREAU 中華民國 REPUBLIC OF CHINA 南北高速公路 NORTH-SOUTH FREEWAY 苗栗台中段 MIAOLI-TAICHUNG SECTION 平面及縱面 PLAN AND PROFILE STA. 134+300 TO STA. 135+000 中華顧問工程司 CHINA ENGINEERING CONSULTANTS, INC. 日期 DATE AUG. '74 比例 SCALE AS SHOWN 圖號 SHEET F-25
項目 ITEM	日期 DATE	

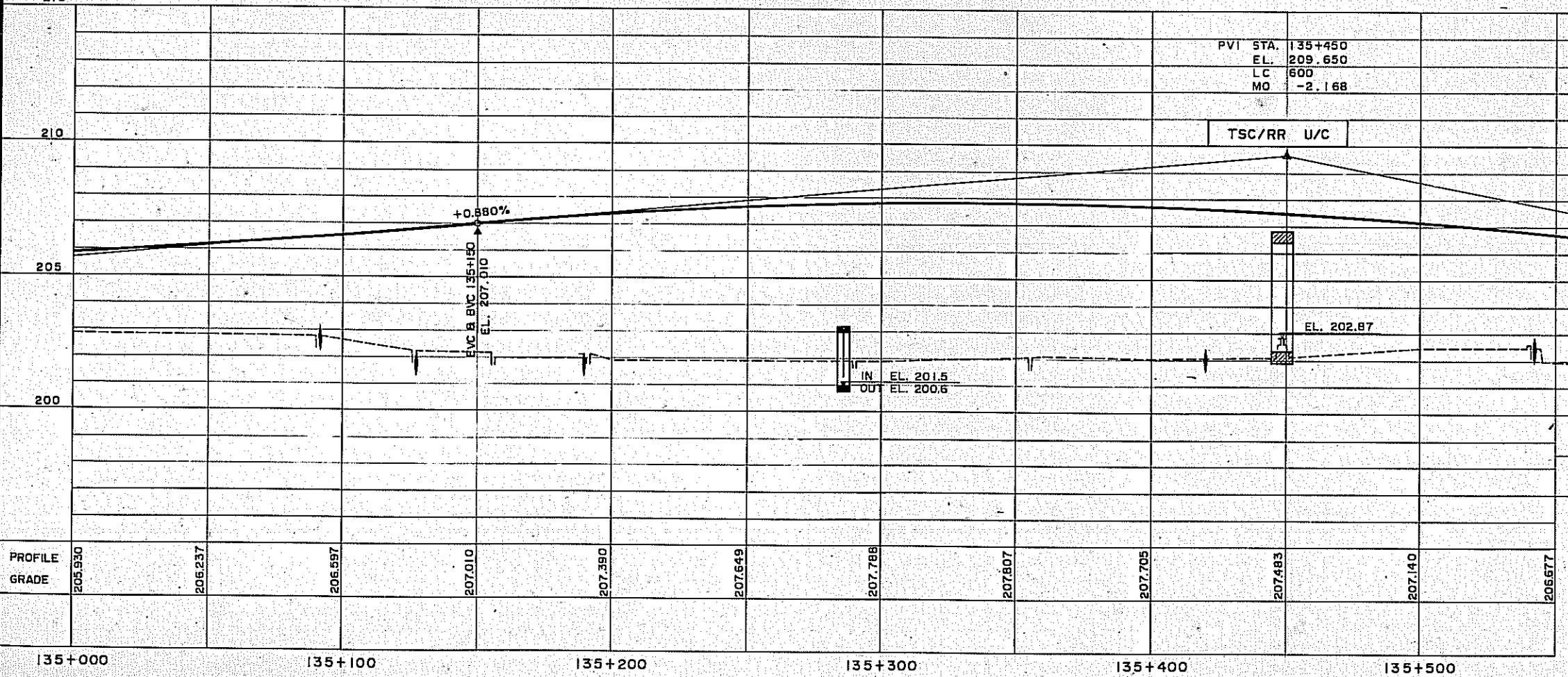
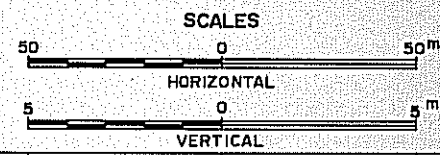
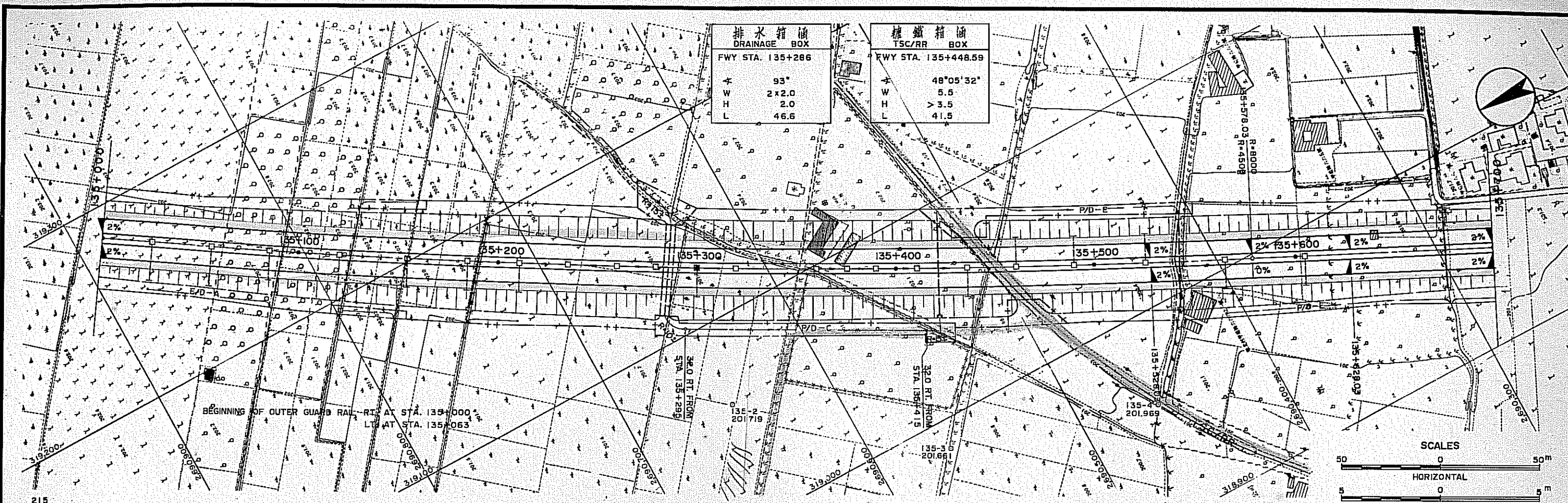

135+600 135+700
PROJECT 60

修正 REVISIONS	
項目 ITEM	日期 DATE

交通部台灣區高速公路工程局
TAIWAN AREA FREEWAY CONSTRUCTION BUREAU
中華民國 REPUBLIC OF CHINA
南北高速公路 NORTH-SOUTH FREEWAY
苗栗台中段 MIAOLI-TAICHUNG SECTION
平面及縱面 PLAN AND PROFILE
STA. 135+000 TO STA. 135+700
中華顧問工程司 CHINA ENGINEERING CONSULTANTS, INC.
日期 DATE AUG. '74 比例 SCALE AS SHOWN 圖號 SHEET F-26

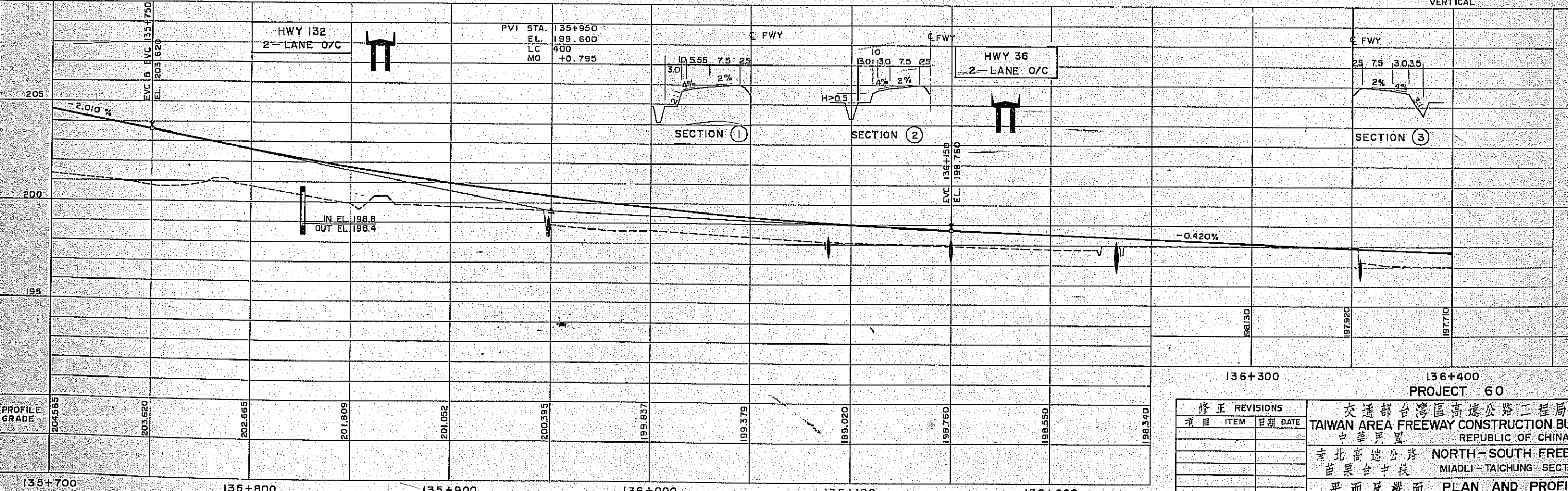
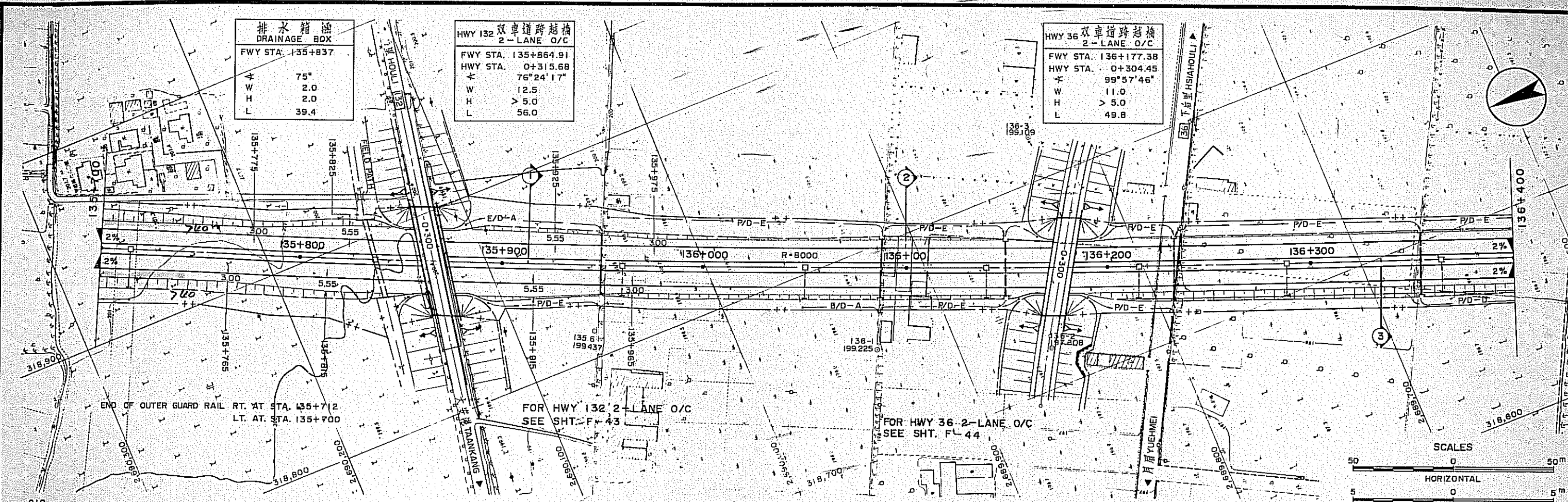

修正 REVISIONS		交通部台湾区高速公路工程局 TAIWAN AREA FREEWAY CONSTRUCTION BUREAU 中華民國 臺北高速公路 NORTH-SOUTH FREEWAY 苗栗台中段 MIAOLI-TAICHUNG SECTION 平面及縱面 PLAN AND PROFILE STA. 135+700 TO STA. 136+400 中華顧問工程司 CHINA ENGINEERING CONSULTANTS, INC. 日期 DATE AUG. '74 比例 SCALE AS SHOWN 圖號 SHEET F-27
項目 ITEM	日期 DATE	

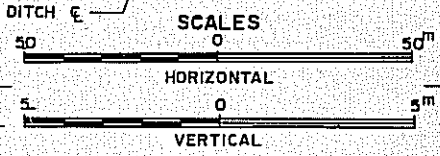
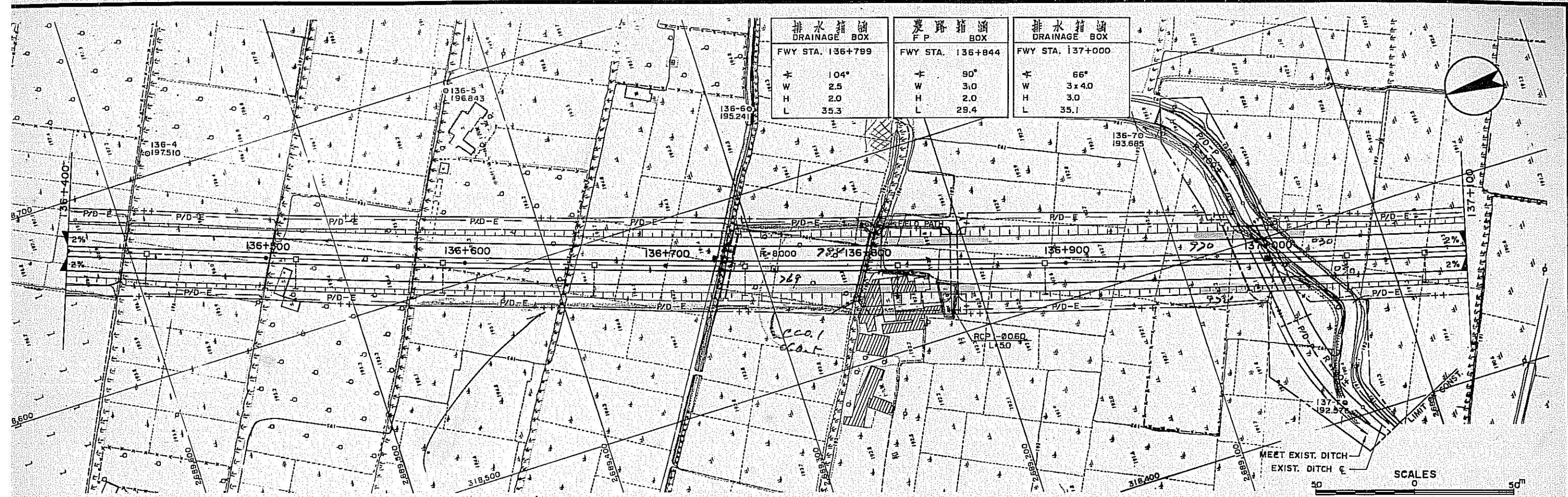

64. 12. 211
 #20-164-415-181
 灌路 = 台天橋路

PVI STA. 136+850
 EL. 195.820
 LC 300
 MO -0.289

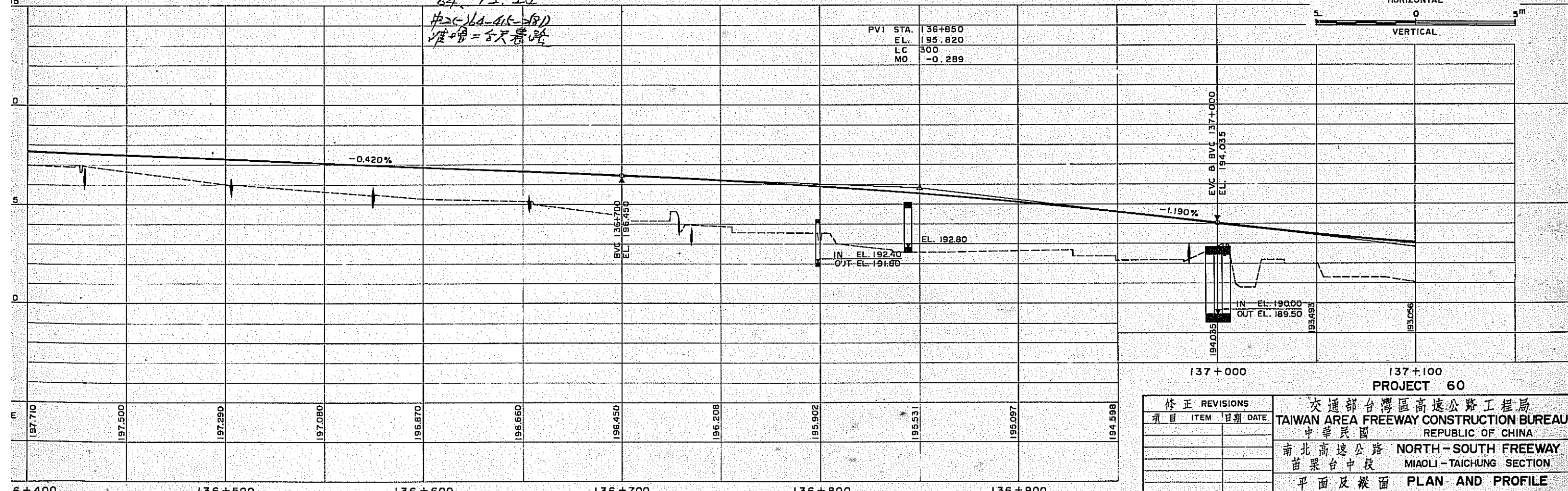

修正 REVISIONS		TAIWAN AREA FREEWAY CONSTRUCTION BUREAU 中華民國 交通部 南北高速公路 苗栗台中段 苗栗台中段 平面及縱面 STA. 136+400 TO STA. 137+100 中華顧問工程司 CHINA ENGINEERING CONSULTANTS, INC. 日期 DATE AUG. '74 比例 SCALE AS SHOWN 圖號 SHEET F-29
項目 ITEM	日期 DATE	

新 162+800

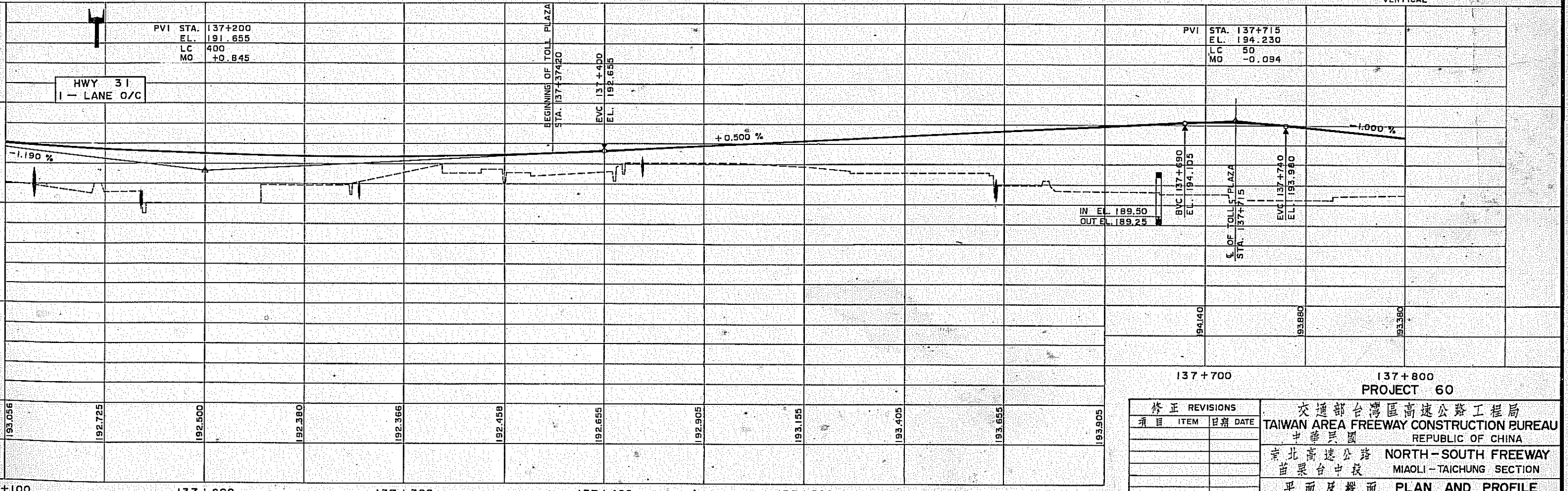
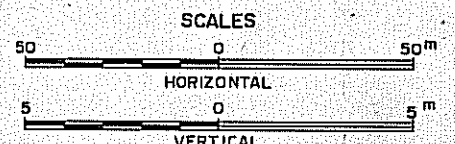
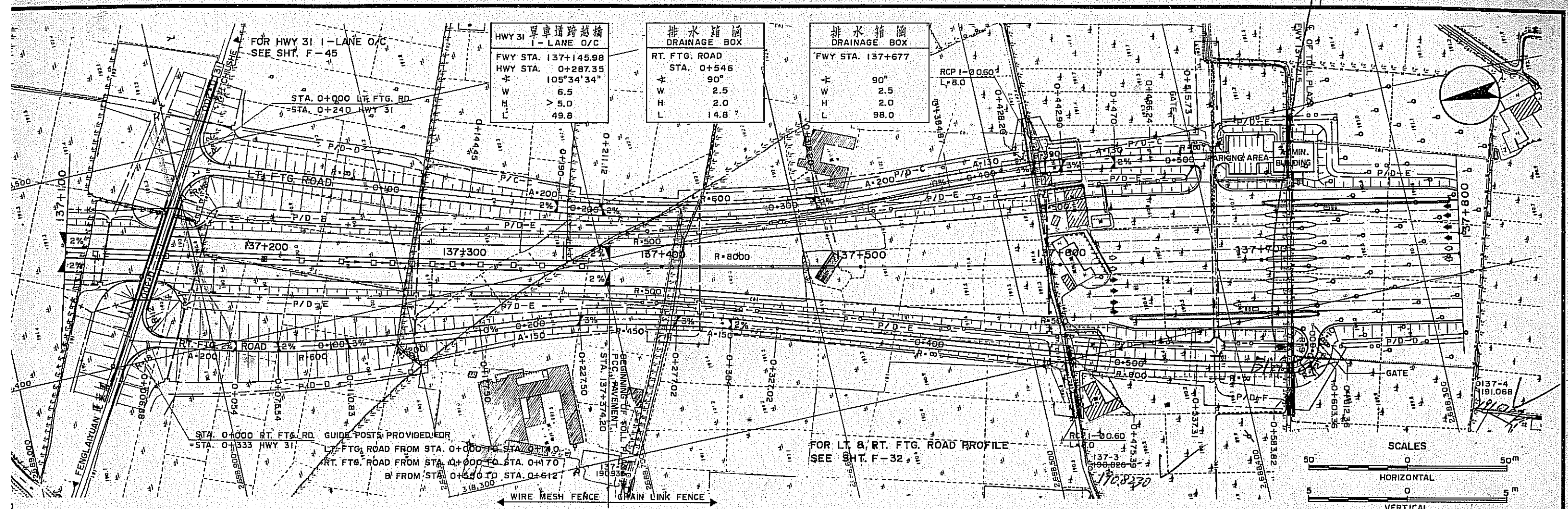

修正 REVISIONS	項目 ITEM	日期 DATE

交通部台灣區高速公路工程局
TAIWAN AREA FREEWAY CONSTRUCTION BUREAU
中華民國
臺北高速公路 NORTH-SOUTH FREEWAY
苗栗台中段 MIAOLI-TAICHUNG SECTION
平面及縱面 PLAN AND PROFILE
STA. 137+100 TO STA. 137+800
中華顧問工程司 CHINA ENGINEERING CONSULTANTS, INC.
DATE AUG. 74 比例 SCALE AS SHOWN 圖號 SHEET F-29

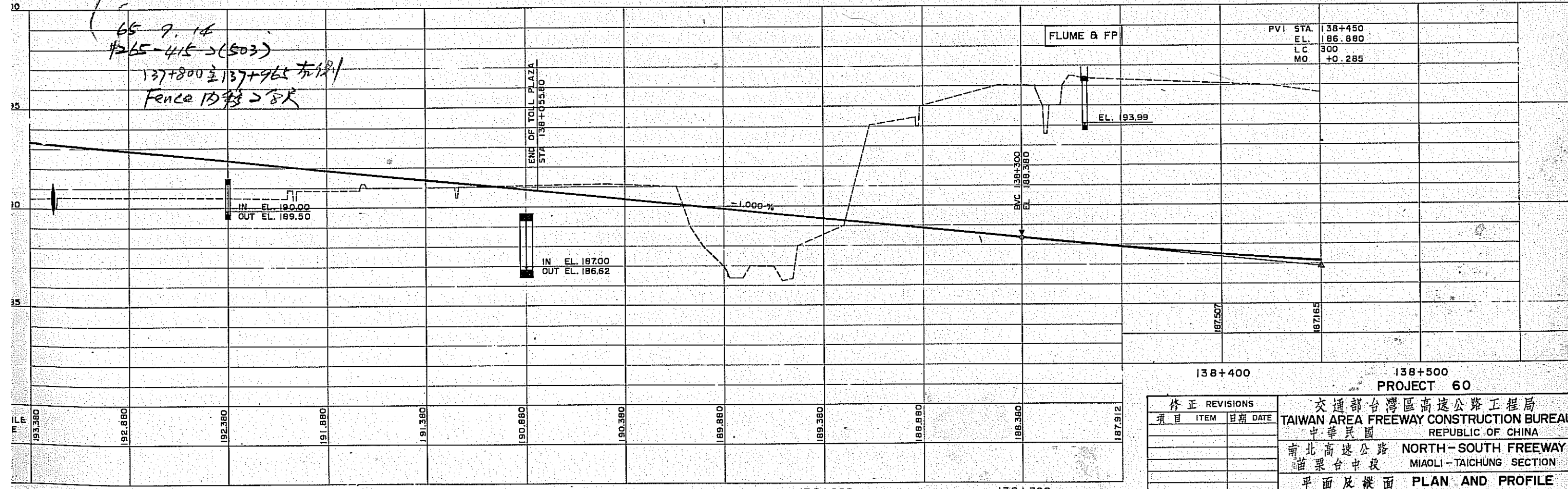
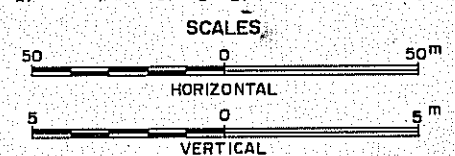
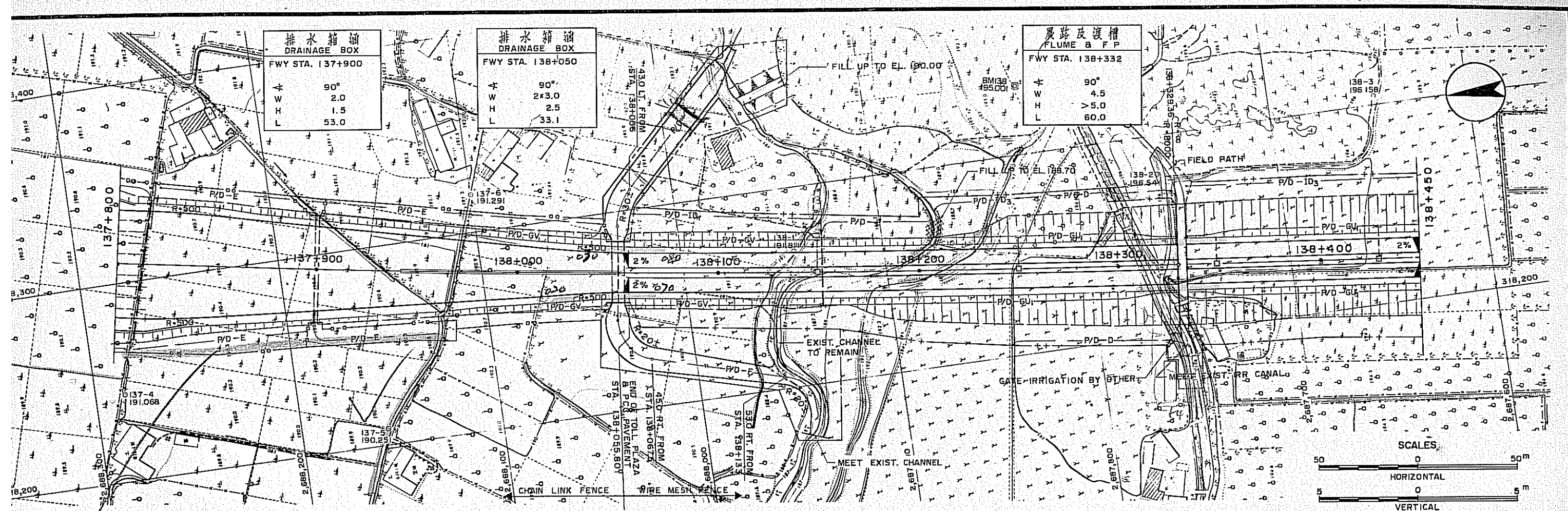

65 9. 14
 1265-415 (503)
 137+800至137+965 右側
 Fence 內移 2 公尺

修正 REVISIONS		交通部台灣區高速公路工程局 TAIWAN AREA FREEWAY CONSTRUCTION BUREAU 中華民國 REPUBLIC OF CHINA 南北高速公路 NORTH-SOUTH FREEWAY 苗栗台中段 MIAOLI-TAICHUNG SECTION 平面及縱面 PLAN AND PROFILE STA. 137+800 TO STA. 138+450 中華顧問工程司 CHINA ENGINEERING CONSULTANTS, INC. 日期 DATE AUG. '74 比例 SCALE AS SHOWN 圖號 SHEET F-30
項目 ITEM	日期 DATE	

大甲溪橋	
RIVER BRIDGE	
FWY STA.	138+620.43
FWY STA.	139+669.57
±	90°
W	2 x 11.5
HWL	180.0
L	1049.14

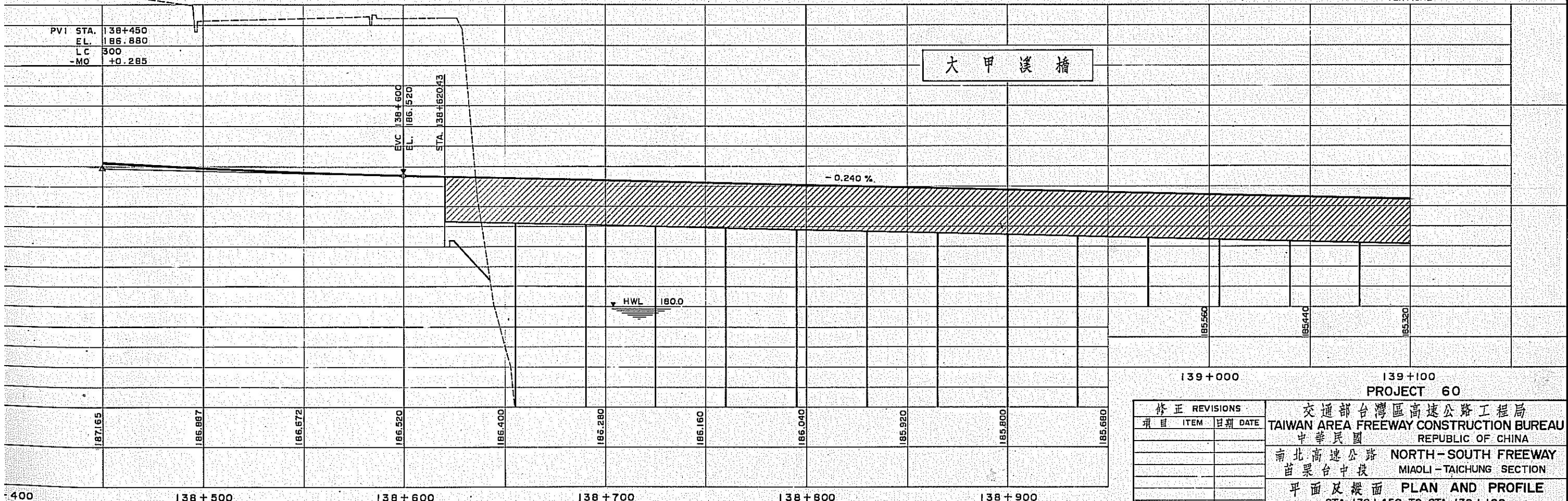
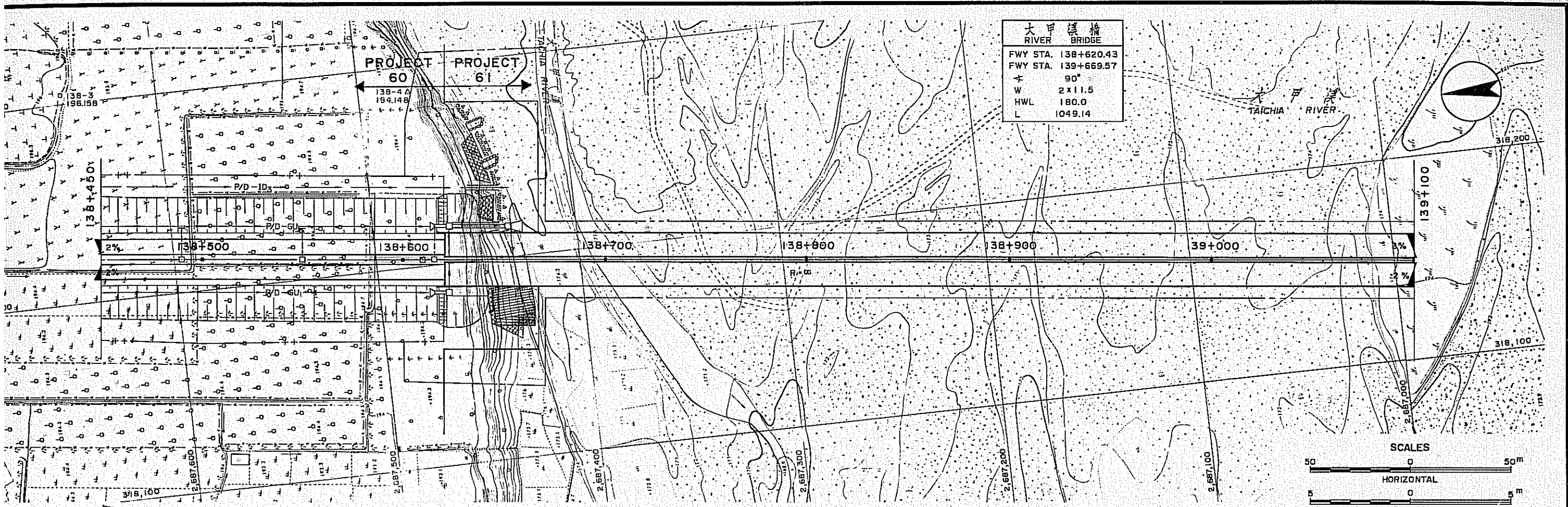
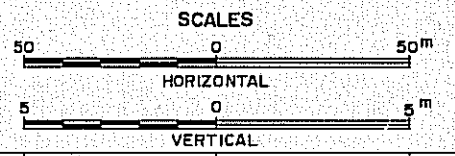

PVI STA.	138+450
EL.	186.880
LC	300
-MO	+0.285

大甲溪橋

139+000 PROJECT 60

修正 REVISIONS	
項目 ITEM	日期 DATE

交通部台灣區高速公路工程局
TAIWAN AREA FREEWAY CONSTRUCTION BUREAU
中華民國 REPUBLIC OF CHINA
南北高速公路 NORTH-SOUTH FREEWAY
苗栗台中段 MIAOLI-TAICHUNG SECTION
平面及縱面 PLAN AND PROFILE
STA. 138+450 TO STA. 139+100
中華顧問工程司 CHINA ENGINEERING CONSULTANTS, INC.
日期 DATE AUG. '74 比例 SCALE AS SHOWN 圖號 SHEET F-31

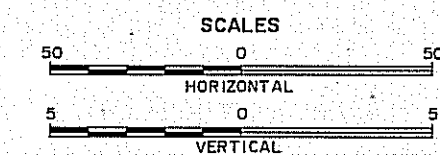
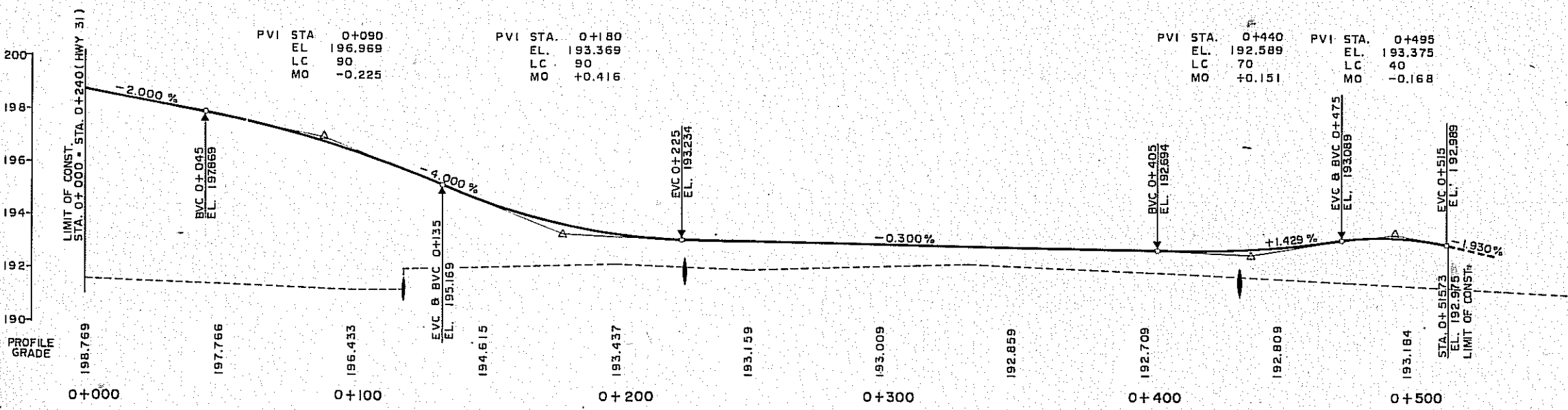
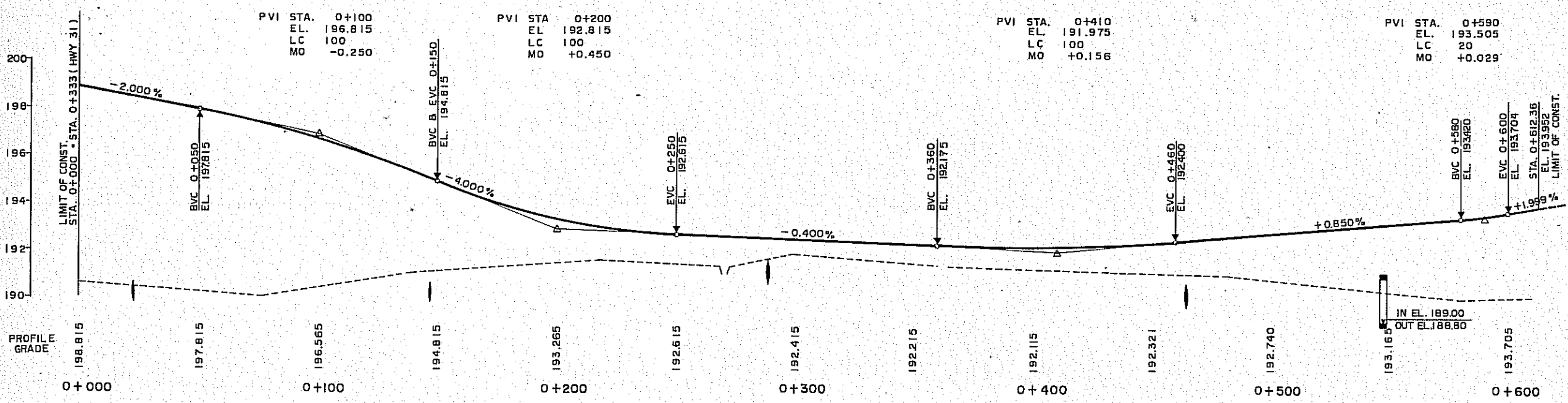

PROJECT 60

修正 REVISIONS	項目 ITEM	日期 DATE

交通部台灣區高速公路工程局
 TAIWAN AREA FREEWAY CONSTRUCTION BUREAU
 中華民國
 中華人民共和國
 南北高速公路 NORTH-SOUTH FREEWAY
 苗栗台中段 MIAOLI-TAICHUNG SECTION
 縱面圖 PROFILES
 接道圖 FRONTAGE ROADS
 中華顧問工程公司 CHINA ENGINEERING CONSULTANTS, INC.
 127-10410-17A, 17B, 17C, 17D, 17E, 17F, 17G, 17H, 17I, 17J, 17K, 17L, 17M, 17N, 17O, 17P, 17Q, 17R, 17S, 17T, 17U, 17V, 17W, 17X, 17Y, 17Z, 17AA, 17AB, 17AC, 17AD, 17AE, 17AF, 17AG, 17AH, 17AI, 17AJ, 17AK, 17AL, 17AM, 17AN, 17AO, 17AP, 17AQ, 17AR, 17AS, 17AT, 17AU, 17AV, 17AW, 17AX, 17AY, 17AZ, 17BA, 17BB, 17BC, 17BD, 17BE, 17BF, 17BG, 17BH, 17BI, 17BJ, 17BK, 17BL, 17BM, 17BN, 17BO, 17BP, 17BQ, 17BR, 17BS, 17BT, 17BU, 17BV, 17BW, 17BX, 17BY, 17BZ, 17CA, 17CB, 17CC, 17CD, 17CE, 17CF, 17CG, 17CH, 17CI, 17CJ, 17CK, 17CL, 17CM, 17CN, 17CO, 17CP, 17CQ, 17CR, 17CS, 17CT, 17CU, 17CV, 17CW, 17CX, 17CY, 17CZ, 17DA, 17DB, 17DC, 17DD, 17DE, 17DF, 17DG, 17DH, 17DI, 17DJ, 17DK, 17DL, 17DM, 17DN, 17DO, 17DP, 17DQ, 17DR, 17DS, 17DT, 17DU, 17DV, 17DW, 17DX, 17DY, 17DZ, 17EA, 17EB, 17EC, 17ED, 17EE, 17EF, 17EG, 17EH, 17EI, 17EJ, 17EK, 17EL, 17EM, 17EN, 17EO, 17EP, 17EQ, 17ER, 17ES, 17ET, 17EU, 17EV, 17EW, 17EX, 17EY, 17EZ, 17FA, 17FB, 17FC, 17FD, 17FE, 17FF, 17FG, 17FH, 17FI, 17FJ, 17FK, 17FL, 17FM, 17FN, 17FO, 17FP, 17FQ, 17FR, 17FS, 17FT, 17FU, 17FV, 17FW, 17FX, 17FY, 17FZ, 17GA, 17GB, 17GC, 17GD, 17GE, 17GF, 17GG, 17GH, 17GI, 17GJ, 17GK, 17GL, 17GM, 17GN, 17GO, 17GP, 17GQ, 17GR, 17GS, 17GT, 17GU, 17GV, 17GW, 17GX, 17GY, 17GZ, 17HA, 17HB, 17HC, 17HD, 17HE, 17HF, 17HG, 17HH, 17HI, 17HJ, 17HK, 17HL, 17HM, 17HN, 17HO, 17HP, 17HQ, 17HR, 17HS, 17HT, 17HU, 17HV, 17HW, 17HX, 17HY, 17HZ, 17IA, 17IB, 17IC, 17ID, 17IE, 17IF, 17IG, 17IH, 17II, 17IJ, 17IK, 17IL, 17IM, 17IN, 17IO, 17IP, 17IQ, 17IR, 17IS, 17IT, 17IU, 17IV, 17IW, 17IX, 17IY, 17IZ, 17JA, 17JB, 17JC, 17JD, 17JE, 17JF, 17JG, 17JH, 17JI, 17JJ, 17JK, 17JL, 17JM, 17JN, 17JO, 17JP, 17JQ, 17JR, 17JS, 17JT, 17JU, 17JV, 17JW, 17JX, 17JY, 17JZ, 17KA, 17KB, 17KC, 17KD, 17KE, 17KF, 17KG, 17KH, 17KI, 17KJ, 17KK, 17KL, 17KM, 17KN, 17KO, 17KP, 17KQ, 17KR, 17KS, 17KT, 17KU, 17KV, 17KW, 17KX, 17KY, 17KZ, 17LA, 17LB, 17LC, 17LD, 17LE, 17LF, 17LG, 17LH, 17LI, 17LJ, 17LK, 17LL, 17LM, 17LN, 17LO, 17LP, 17LQ, 17LR, 17LS, 17LT, 17LU, 17LV, 17LW, 17LX, 17LY, 17LZ, 17MA, 17MB, 17MC, 17MD, 17ME, 17MF, 17MG, 17MH, 17MI, 17MJ, 17MK, 17ML, 17MN, 17MO, 17MP, 17MQ, 17MR, 17MS, 17MT, 17MU, 17MV, 17MW, 17MX, 17MY, 17MZ, 17NA, 17NB, 17NC, 17ND, 17NE, 17NF, 17NG, 17NH, 17NI, 17NJ, 17NK, 17NL, 17NM, 17NO, 17NP, 17NQ, 17NR, 17NS, 17NT, 17NU, 17NV, 17NW, 17NX, 17NY, 17NZ, 17OA, 17OB, 17OC, 17OD, 17OE, 17OF, 17OG, 17OH, 17OI, 17OJ, 17OK, 17OL, 17OM, 17ON, 17OO, 17OP, 17OQ, 17OR, 17OS, 17OT, 17OU, 17OV, 17OW, 17OX, 17OY, 17OZ, 17PA, 17PB, 17PC, 17PD, 17PE, 17PF, 17PG, 17PH, 17PI, 17PJ, 17PK, 17PL, 17PM, 17PN, 17PO, 17PP, 17PQ, 17PR, 17PS, 17PT, 17PU, 17PV, 17PW, 17PX, 17PY, 17PZ, 17QA, 17QB, 17QC, 17QD, 17QE, 17QF, 17QG, 17QH, 17QI, 17QJ, 17QK, 17QL, 17QM, 17QN, 17QO, 17QP, 17QQ, 17QR, 17QS, 17QT, 17QU, 17QV, 17QW, 17QX, 17QY, 17QZ, 17RA, 17RB, 17RC, 17RD, 17RE, 17RF, 17RG, 17RH, 17RI, 17RJ, 17RK, 17RL, 17RM, 17RN, 17RO, 17RP, 17RQ, 17RR, 17RS, 17RT, 17RU, 17RV, 17RW, 17RX, 17RY, 17RZ, 17SA, 17SB, 17SC, 17SD, 17SE, 17SF, 17SG, 17SH, 17SI, 17SJ, 17SK, 17SL, 17SM, 17SN, 17SO, 17SP, 17SQ, 17SR, 17SS, 17ST, 17SU, 17SV, 17SW, 17SX, 17SY, 17SZ, 17TA, 17TB, 17TC, 17TD, 17TE, 17TF, 17TG, 17TH, 17TI, 17TJ, 17TK, 17TL, 17TM, 17TN, 17TO, 17TP, 17TQ, 17TR, 17TS, 17TT, 17TU, 17TV, 17TW, 17TX, 17TY, 17TZ, 17UA, 17UB, 17UC, 17UD, 17UE, 17UF, 17UG, 17UH, 17UI, 17UJ, 17UK, 17UL, 17UM, 17UN, 17UO, 17UP, 17UQ, 17UR, 17US, 17UT, 17UU, 17UV, 17UW, 17UX, 17UY, 17UZ, 17VA, 17VB, 17VC, 17VD, 17VE, 17VF, 17VG, 17VH, 17VI, 17VJ, 17VK, 17VL, 17VM, 17VN, 17VO, 17VP, 17VQ, 17VR, 17VS, 17VT, 17VU, 17VV, 17VW, 17VX, 17VY, 17VZ, 17WA, 17WB, 17WC, 17WD, 17WE, 17WF, 17WG, 17WH, 17WI, 17WJ, 17WK, 17WL, 17WM, 17WN, 17WO, 17WP, 17WQ, 17WR, 17WS, 17WT, 17WU, 17WV, 17WW, 17WX, 17WY, 17WZ, 17XA, 17XB, 17XC, 17XD, 17XE, 17XF, 17XG, 17XH, 17XI, 17XJ, 17XK, 17XL, 17XM, 17XN, 17XO, 17XP, 17XQ, 17XR, 17XS, 17XT, 17XU, 17XV, 17XW, 17XX, 17XY, 17XZ, 17YA, 17YB, 17YC, 17YD, 17YE, 17YF, 17YG, 17YH, 17YI, 17YJ, 17YK, 17YL, 17YM, 17YN, 17YO, 17YP, 17YQ, 17YR, 17YS, 17YT, 17YU, 17YV, 17YW, 17YX, 17YY, 17YZ, 17ZA, 17ZB, 17ZC, 17ZD, 17ZE, 17ZF, 17ZG, 17ZH, 17ZI, 17ZJ, 17ZK, 17ZL, 17ZM, 17ZN, 17ZO, 17ZP, 17ZQ, 17ZR, 17ZS, 17ZT, 17ZU, 17ZV, 17ZW, 17ZX, 17ZY, 17ZZ

Ramp 1. 0+608 ~ 0+852.6
 Ramp 4. 0+500 ~ 0+614.8
 Ramp 5. 0+000 ~ 0+045

停車場 } 取消不作

双車道及渡槽	
FLUME B 2-LANE O/C	
FWY STA.	133+680.50
RAMP "1" STA.	0+427.98
A	81°49'54"
W	11.0
H	>5.0
L	74.0

農路排灌	
FP	BOX
RAMP "1" STA	0+546.00
RAMP "4" STA	0+457.06
A	46°41'32"
W	3.0
H	3.0
L	33.8

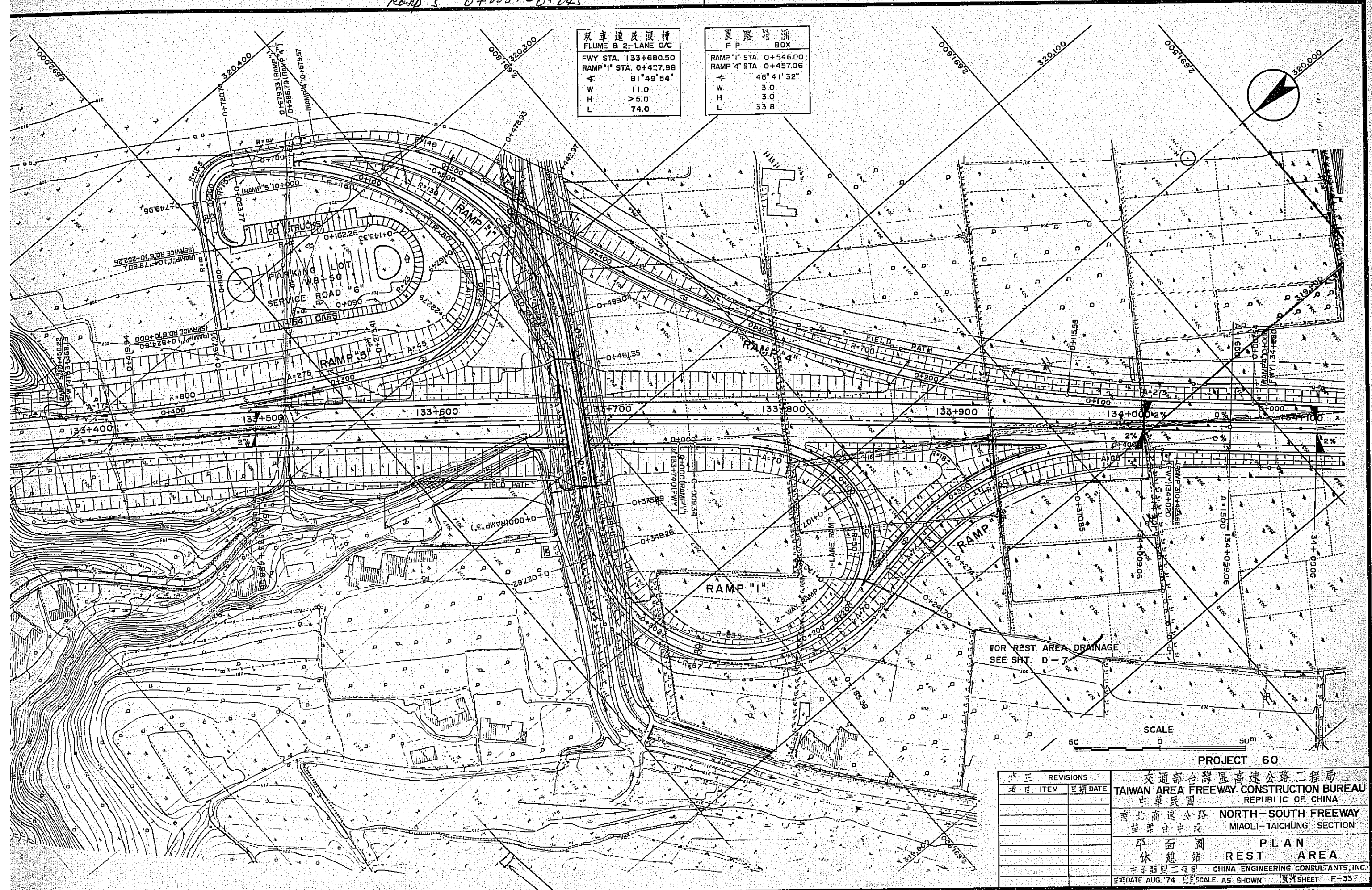

FOR REST AREA DRAINAGE
 SEE SHT. D-7



PROJECT 60

三	REVISIONS	交通部台灣區高速公路工程局
項	ITEM	TAIWAN AREA FREEWAY CONSTRUCTION BUREAU
目	日期 DATE	中華民國
		臺北高速公路
		苗栗台中段
		NORTH-SOUTH FREEWAY
		苗栗台中段
		MIAOLI-TAICHUNG SECTION
		平面圖
		REST AREA
		中國工程顧問公司
		CHINA ENGINEERING CONSULTANTS, INC.
		日期 DATE AUG. '74
		比例 SCALE AS SHOWN
		圖號 SHEET F-33

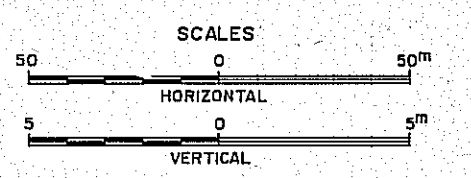
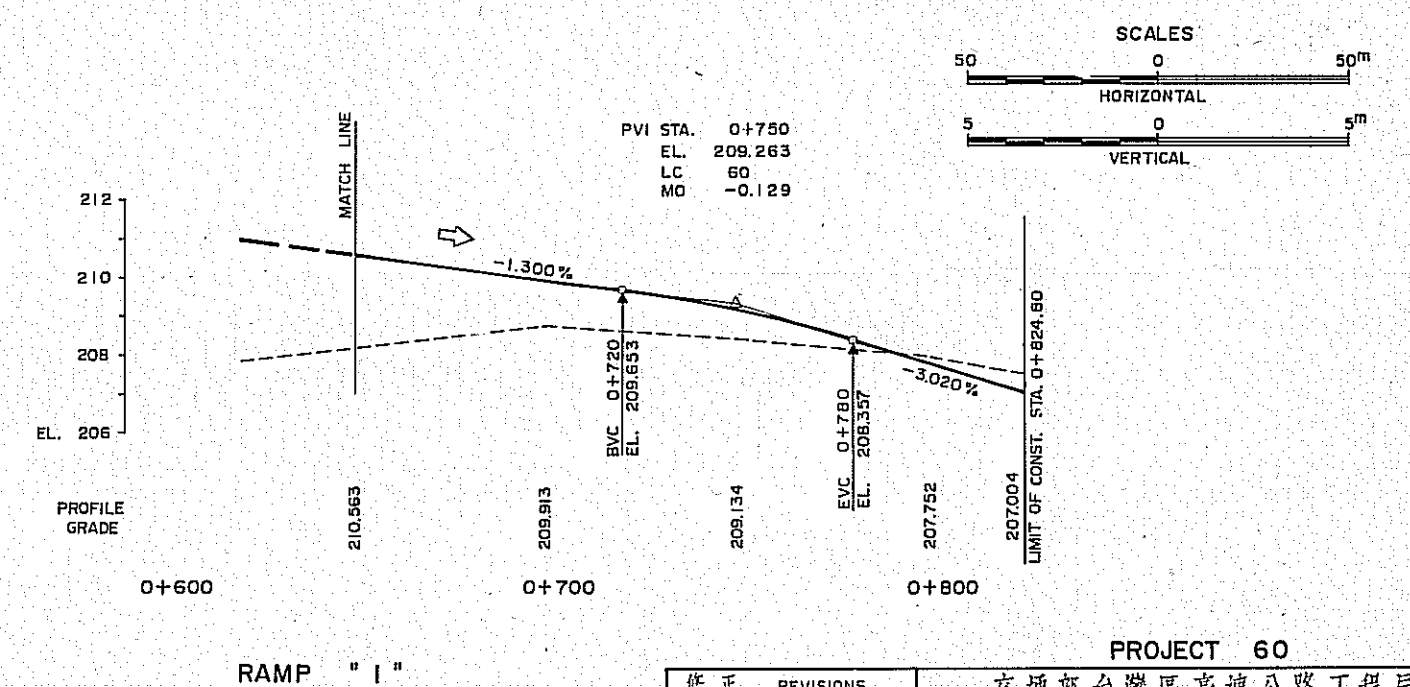
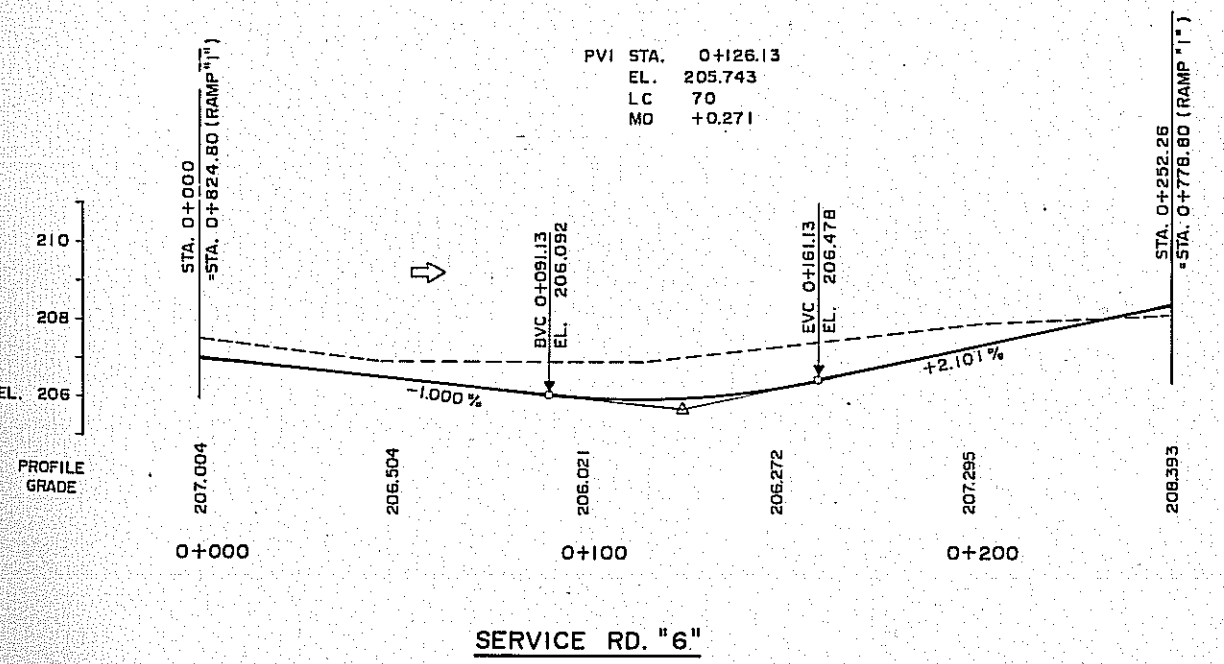
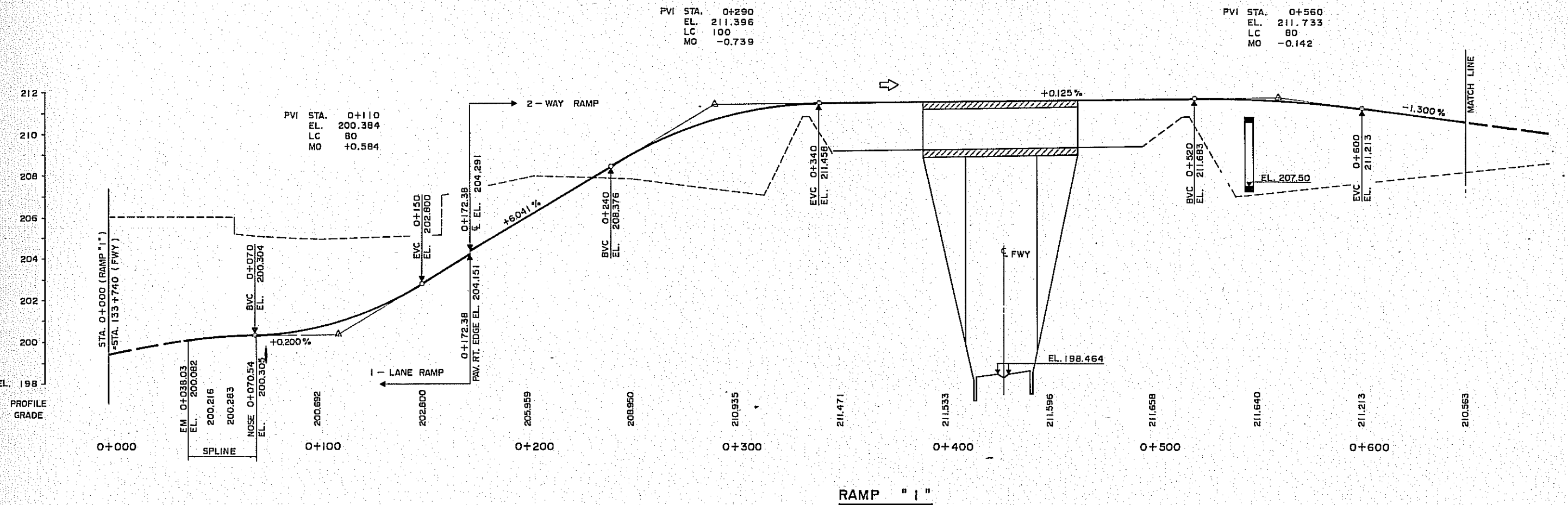

SERVICE RD. "6"

RAMP "1"

PROJECT 60

修正	REVISIONS	項目	ITEM	日期	DATE

交通部台灣區高速公路工程局
TAIWAN AREA FREEWAY CONSTRUCTION BUREAU
中華民國
REPUBLIC OF CHINA
南北高速公路
NORTH-SOUTH FREEWAY
苗栗台中段
MIAOLI-TAICHUNG SECTION
縱面圖-1
PROFILES-1
林壠站
REST AREA
中華顧問工程司
CHINA ENGINEERING CONSULTANTS, INC.
日期 DATE AUG. '74 比例 SCALE AS SHOWN 附錄 APPENDIX F-34

FILE
ADE

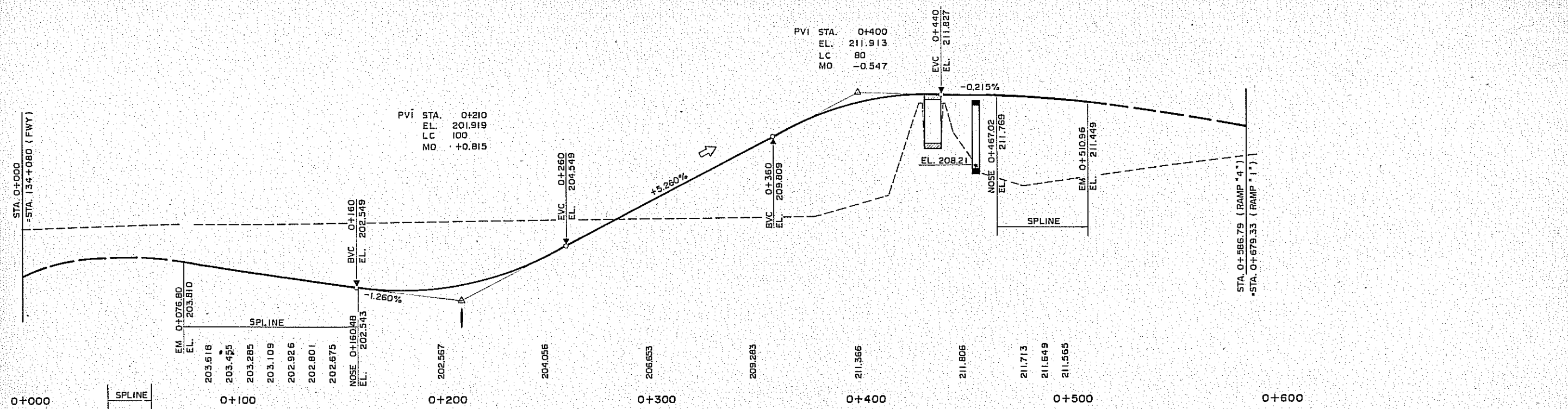

RAMP " 4 "

FILE
ADE

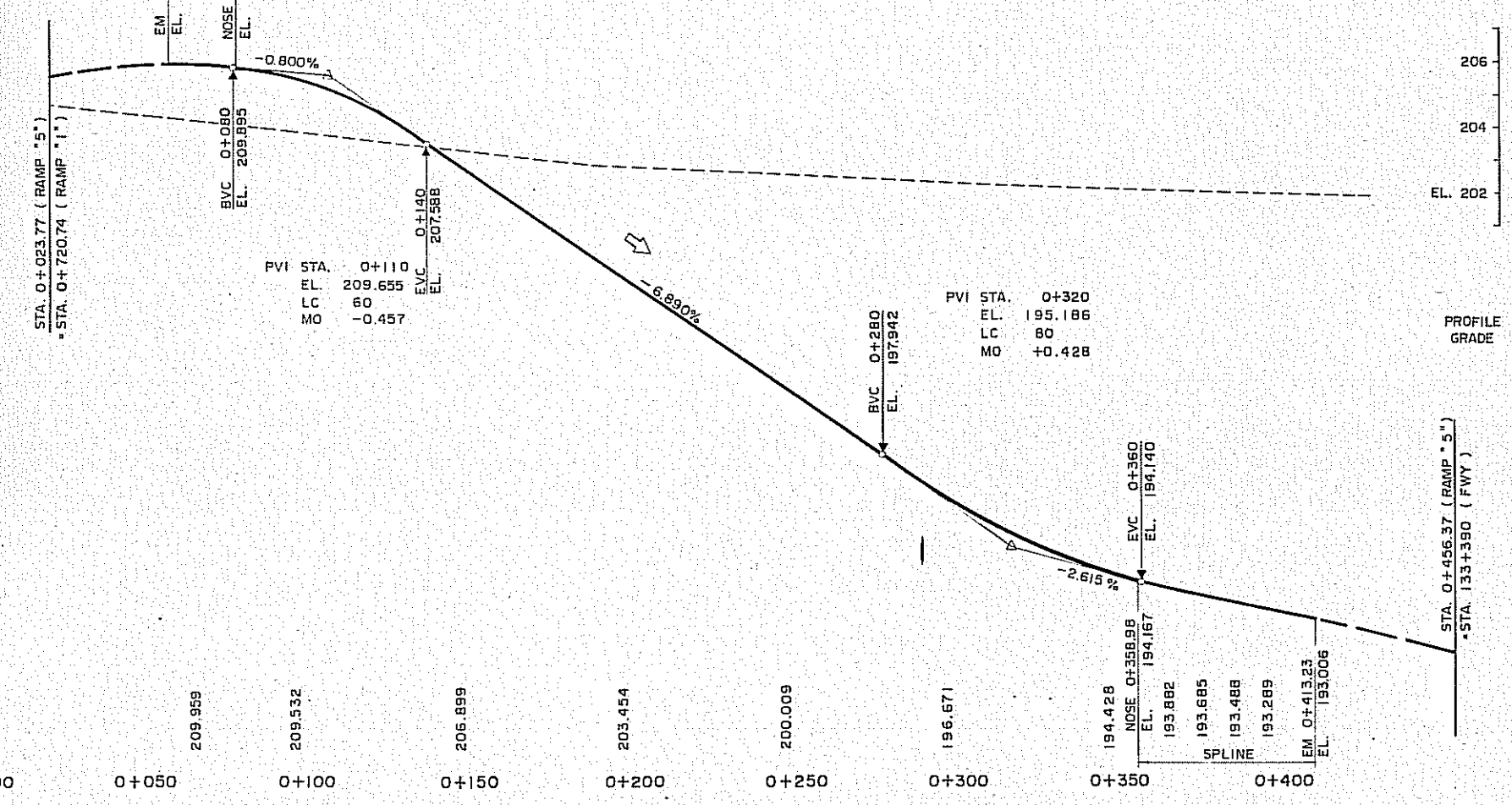

RAMP " 5 "

PROFILE
GRADE

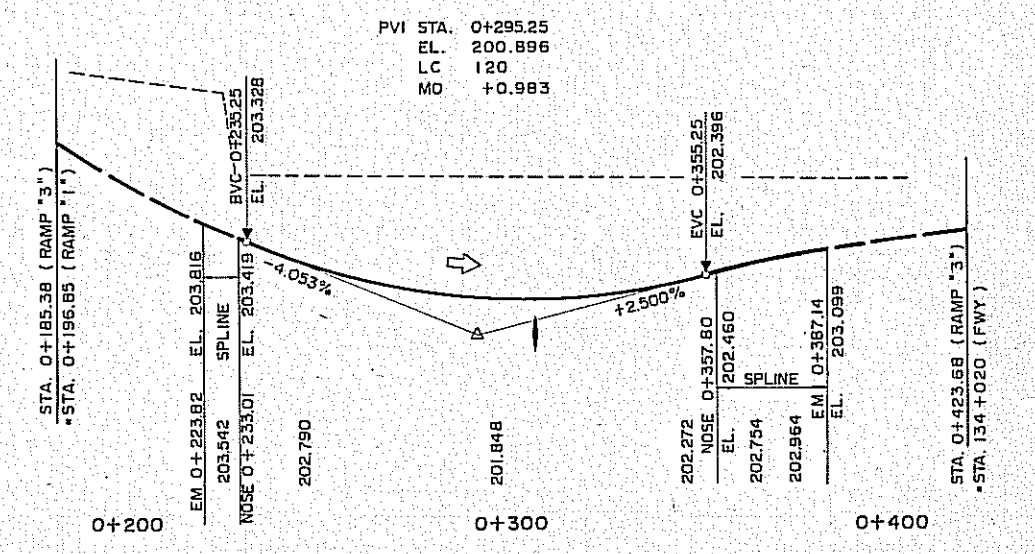

RAMP " 3 "

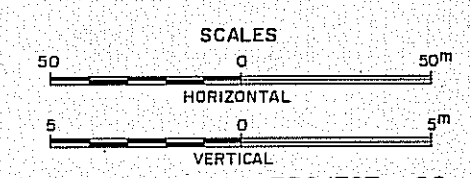

PROJECT 60

NO.	REVISIONS	DATE

交通部台灣區高速公路工程局
TAIWAN AREA FREEWAY CONSTRUCTION BUREAU
中華民國
REPUBLIC OF CHINA
南北向高速公路
NORTH-SOUTH FREEWAY
苗栗至台中段
MIAOLI-TAICHUNG SECTION
剖面圖-2
PROFILES - 2
休息站
REST AREA
中國工程顧問公司
CHINA ENGINEERING CONSULTANTS, INC.
DATE AUG '74 SCALE AS SHOWN APPENDIX F-35

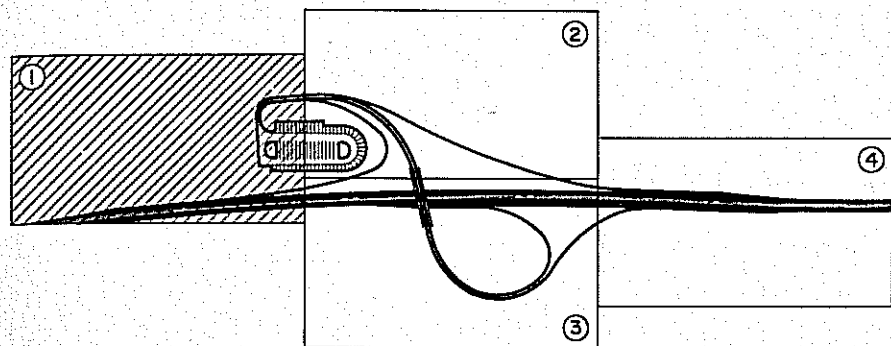

KEY PLAN
SCALE 1: 5000

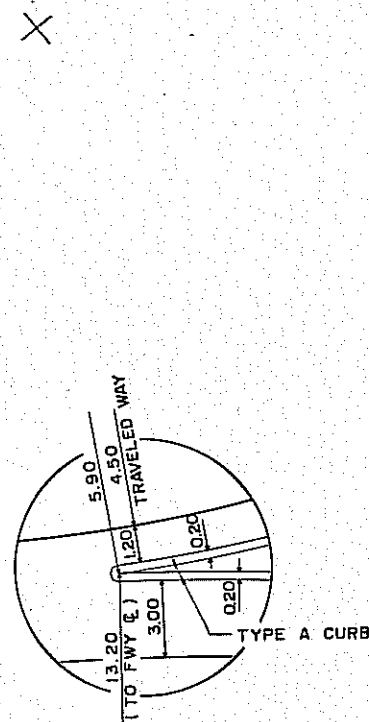

DETAIL A

說明：

- ④ 示路面標誌標準型式編號請參閱 FT-12.
- 延伸車道橫坡相交於叉端線。

NOTES:

- ④ SHOWS PAVEMENT MARKING DETAIL NUMBER, SEE SHT. FT-12.
- EXTEND THE TRAVELED WAY PAVEMENT CROSS SLOPES TO MEET AT NOSE RIDGE LINE.

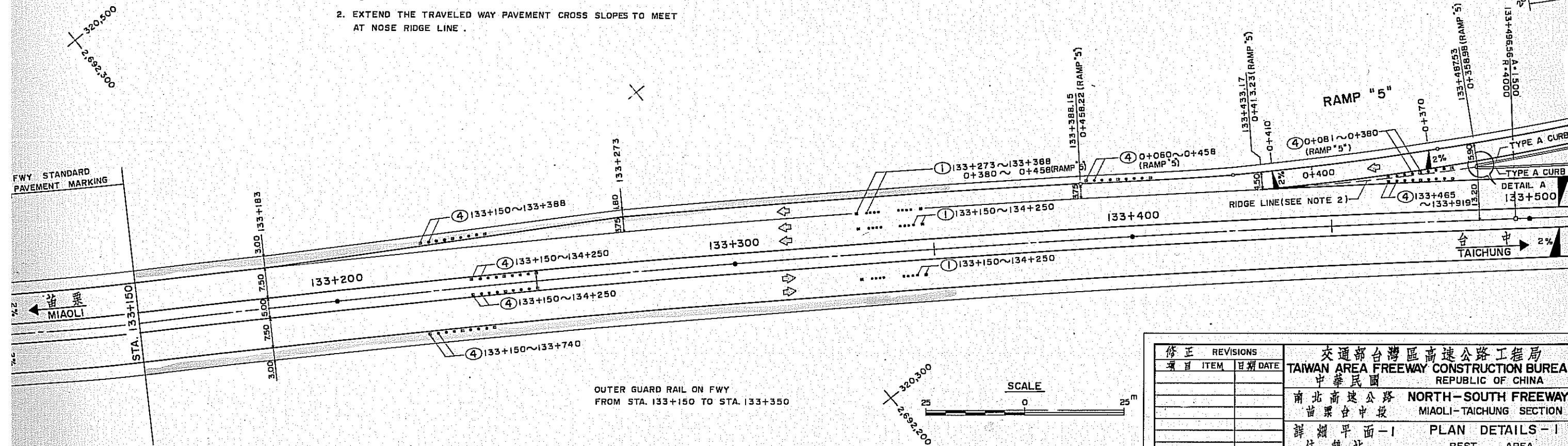

OUTER GUARD RAIL ON FWY
FROM STA. 133+150 TO STA. 133+350

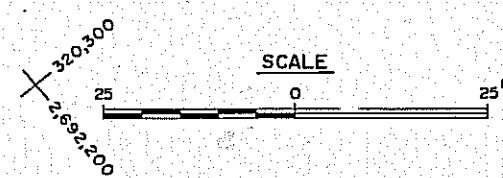

修正 項目	REVISIONS ITEM	日期 DATE

交通部台灣區高速公路工程局
TAIWAN AREA FREEWAY CONSTRUCTION BUREAU
中華民國
REPUBLIC OF CHINA
南北高速公路
NORTH-SOUTH FREEWAY
苗栗台中段
MIAOLI-TAICHUNG SECTION
詳細平面-1
PLAN DETAILS - 1
休息站
REST AREA
中興顧問工程司
CHINA ENGINEERING CONSULTANTS, INC.
日期 DATE AUG. '74 比例 SCALE AS SHOWN 圖號 SHEET F-36

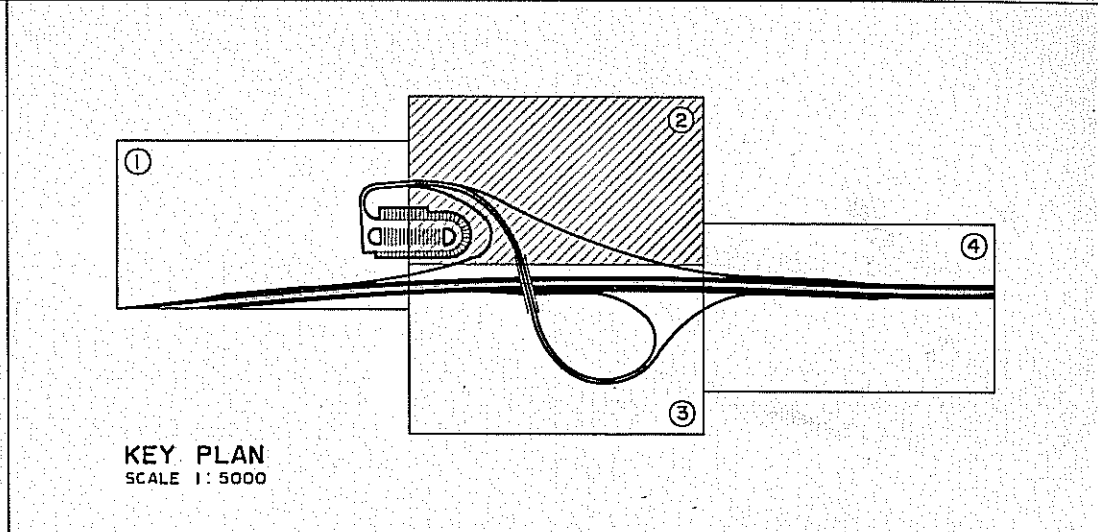
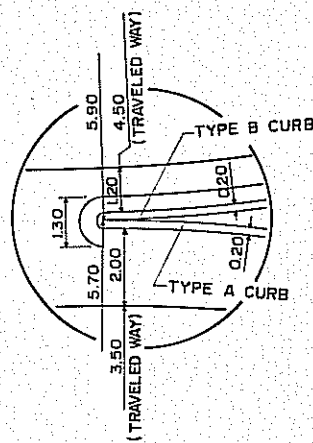
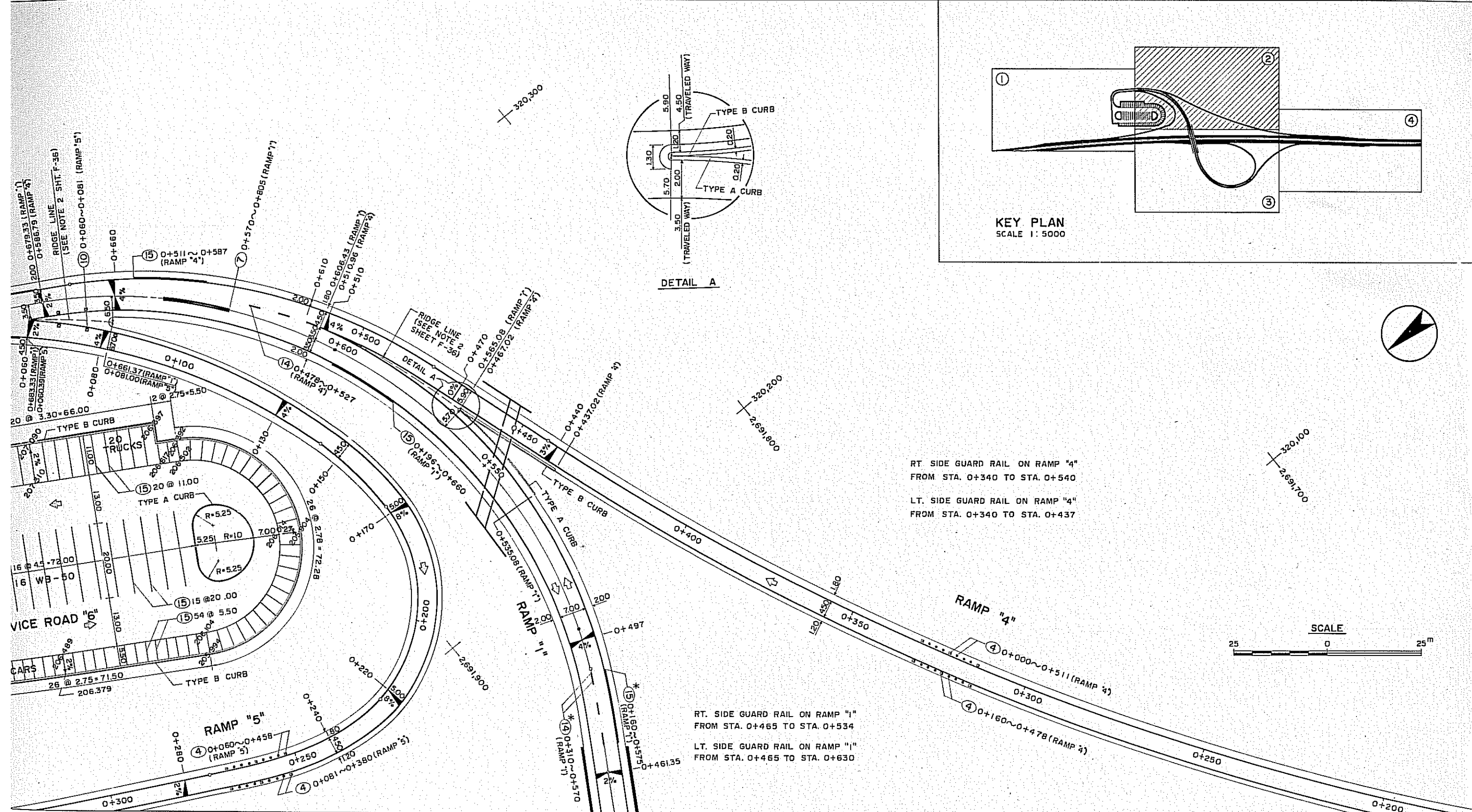

* SIDEWALK PROVIDED ON THE 2-LANE O/C AT FWY STA. 133+680.50, PAVEMENT WIDTH OF RAMP "1" DECREASED 2^M. EDGE MARKING AND ϵ STRIPING SHALL BE PAINTED AS 7.0^M TWO WAY TRAVELED WAY WITH 1.0^M SHOULDER ON BOTH SIDES. 25:1 TRANSITIONAL APPROACHES FOR PAINTING CONTINUATIONS SHALL BE USED.

說明請參閱圖 F-36
FOR NOTES SEE SHEET F-36

修正 項目	REVISIONS ITEM	日期 DATE

交通部台灣區高速公路工程局
TAIWAN AREA FREEWAY CONSTRUCTION BUREAU
中華民國
中華人民共和國
南北高速公路 NORTH-SOUTH FREEWAY
苗栗台中段 MIAOLI-TAICHUNG SECTION
詳細平面-2 PLAN DETAILS-2
休息站 REST AREA
中華顧問工程司 CHINA ENGINEERING CONSULTANTS, INC.
日期 DATE AUG. '74 比例 SCALE AS SHOWN 圖號 SHEET F-37

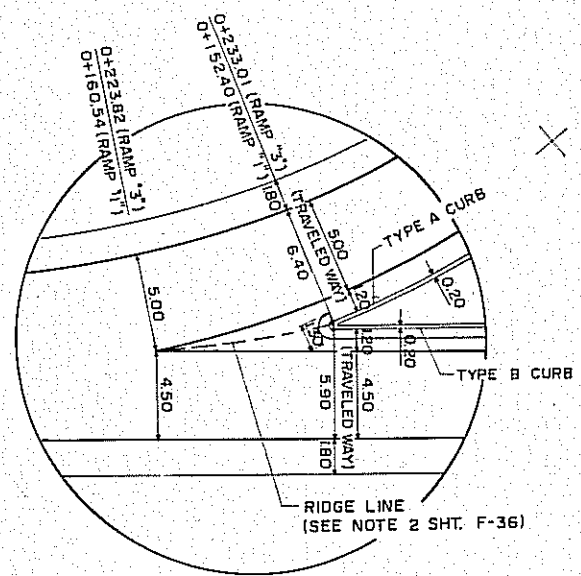
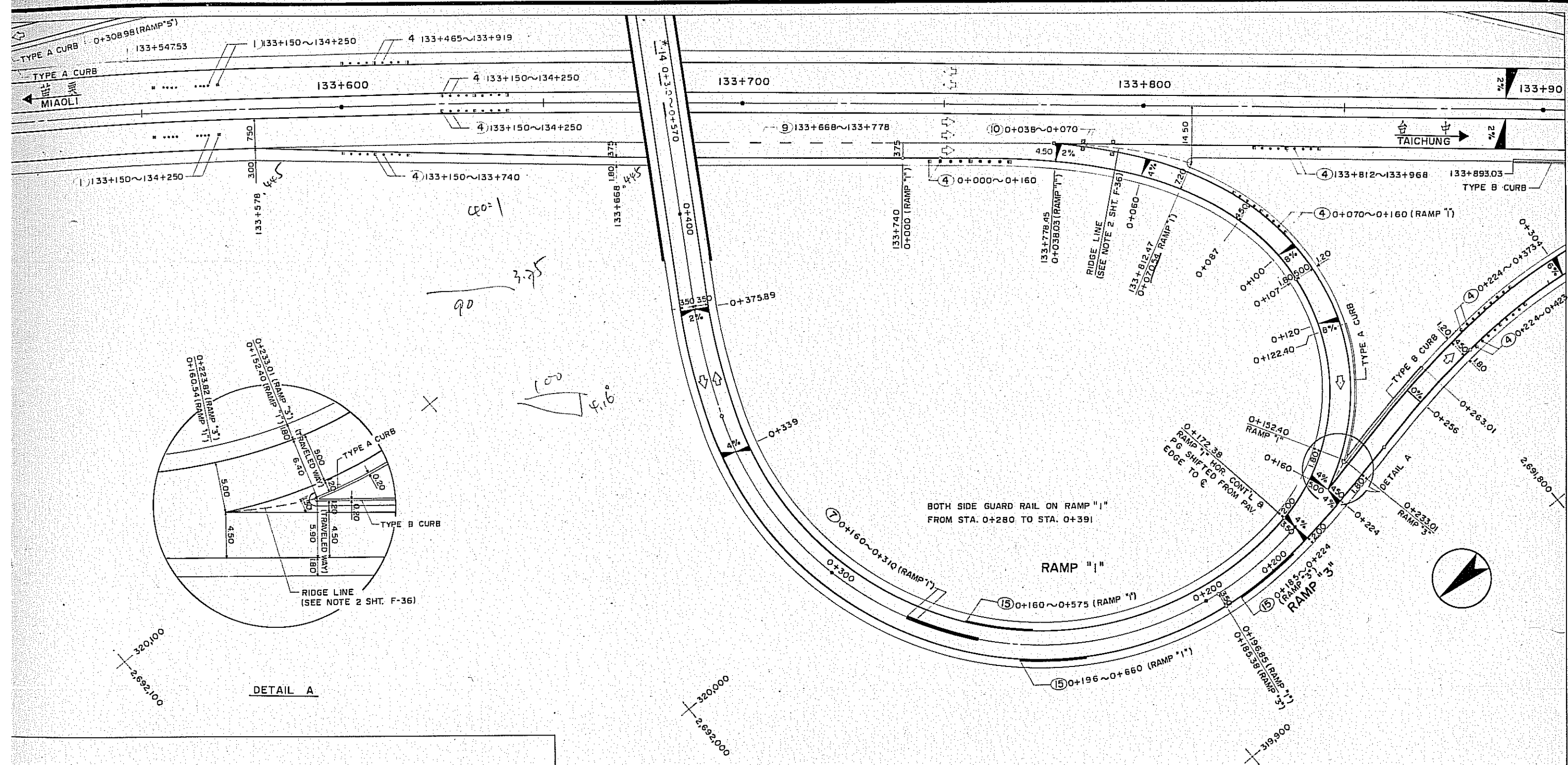

DETAIL A

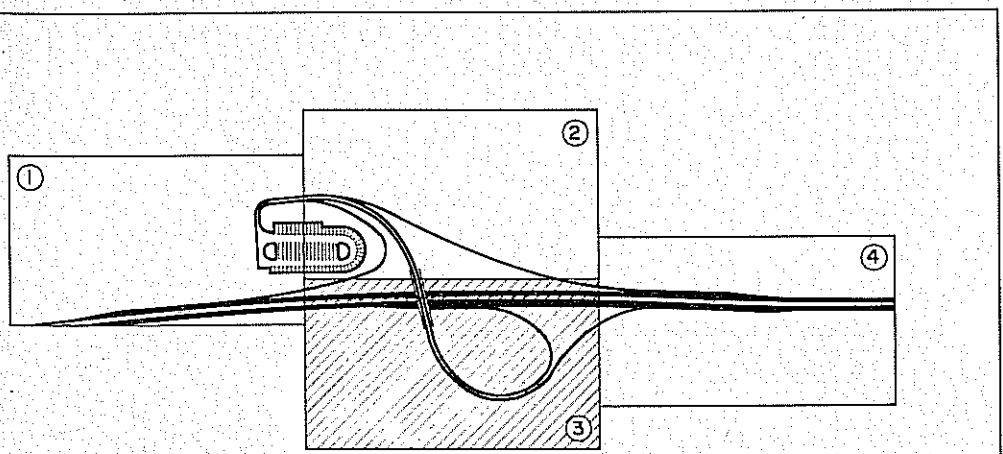

KEY PLAN
SCALE 1:5000

說明請參閱圖 F-36
FOR NOTES SEE SHEET F-36

* SIDEWALK PROVIDED ON THE 2-LANE O/C AT FWY STA. 133+680.50, PAVEMENT WIDTH OF RAMP "1" DECREASED 2^M. EDGE MARKING AND C STRIPING SHALL BE PAINTED AS 7.0^M TWO WAY TRAVELED WAY WITH 1.0^M SHOULDER ON BOTH SIDES. 25:1 TRANSITIONAL APPROACHES FOR PAINTING CONTINUATIONS SHALL BE USED.

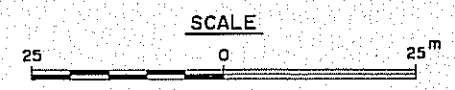

修正 REVISIONS	項目 ITEM	日期 DATE

交通部台灣區高速公路工程局
TAIWAN AREA FREEWAY CONSTRUCTION BUREAU
中華民國 REPUBLIC OF CHINA
南北高速公路 NORTH-SOUTH FREEWAY
苗栗台中段 MIAOLI-TAICHUNG SECTION
詳細平面-3 PLAN DETAILS-3
休息站 REST AREA
中華顧問工程司 CHINA ENGINEERING CONSULTANTS, INC.
日期 DATE AUG. '74 出圖 SCALE AS SHOWN 圖號 SHEET F-38

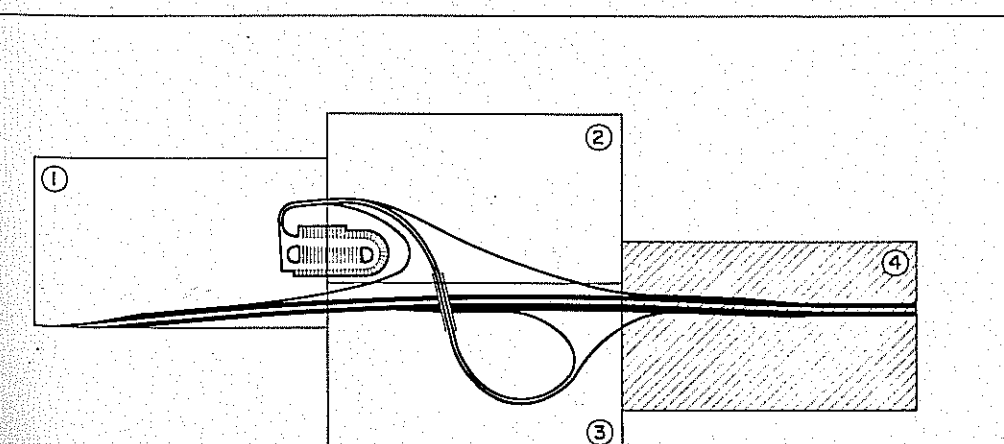
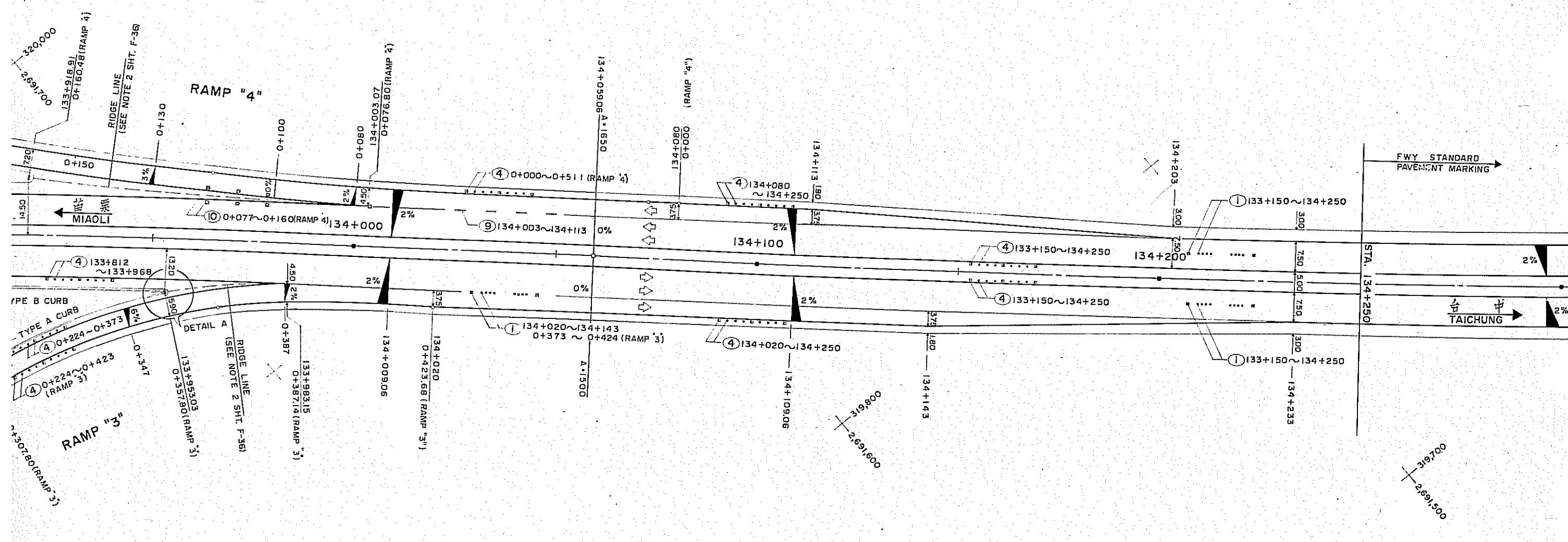

KEY PLAN
SCALE 1:5000

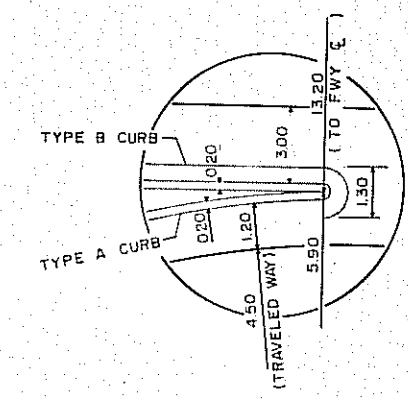

DETAIL A

說明請參閱圖 F-36
FOR NOTES SEE SHET F-36

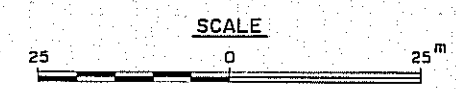

修正 REVISIONS	項目 ITEM	日期 DATE

交通部台灣區高速公路工程局
TAIWAN AREA FREEWAY CONSTRUCTION BUREAU
中華民國
南北高速公路 NORTH-SOUTH FREEWAY
苗栗-中段 MIAOLI-TAICHUNG SECTION
詳細平面-4 PLAN DETAILS-4
休息站 REST AREA
中華顧問工程司 CHINA ENGINEERING CONSULTANTS, INC.
日期 DATE AUG. '74 比例 SCALE AS SHOWN 圖號 SHEET F-39

65.5.14.
 #265-415-2(249) 蔣平華
 同定 0+290~0+800 RT
 0+360~0+800 LT
 =8R 蔣平華

HWY 44	單車道跨越橋
	1 - LANE O/C
FWY STA.	132+246.82
HWY STA.	0+334.79
Δ	73°22'29"
W	6.5
H	> 5.0
L	49.8

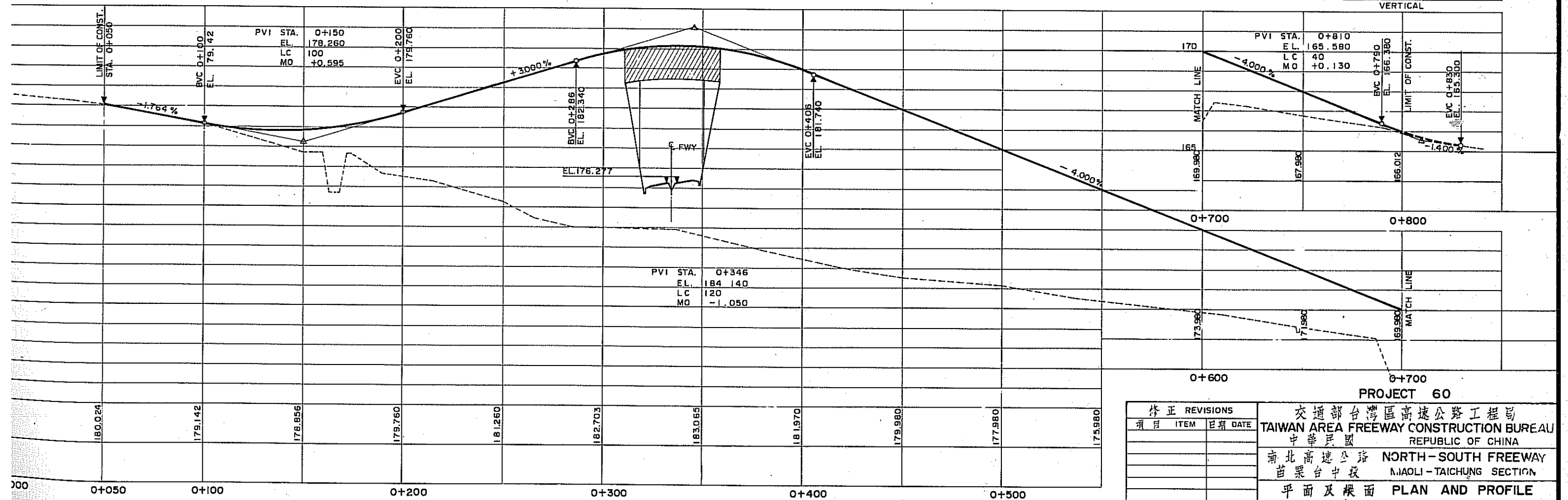
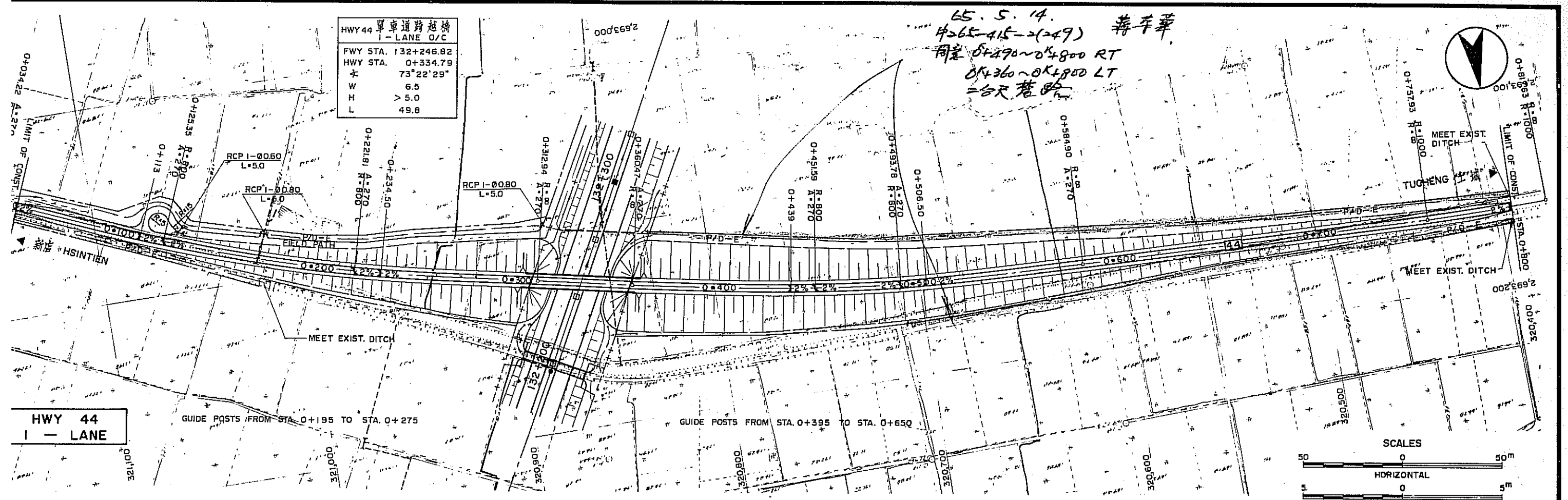

修正 REVISIONS			交通部台灣區高速公路工程局 TAIWAN AREA FREEWAY CONSTRUCTION BUREAU 中華民國 台北高速公路 苗栗台中段	PROJECT 60 NORTH-SOUTH FREEWAY MIAOLI-TAICHUNG SECTION
項目 ITEM	日期 DATE			
			平面及縱面 PLAN AND PROFILE	
			HWY 44 AT FWY STA. 132+246.82	
			中研顧問工程司 CHINA ENGINEERING CONSULTANTS, INC.	
			日期 DATE AUG. '74 比例 SCALE AS SHOWN 圖號 SHEET F-40	

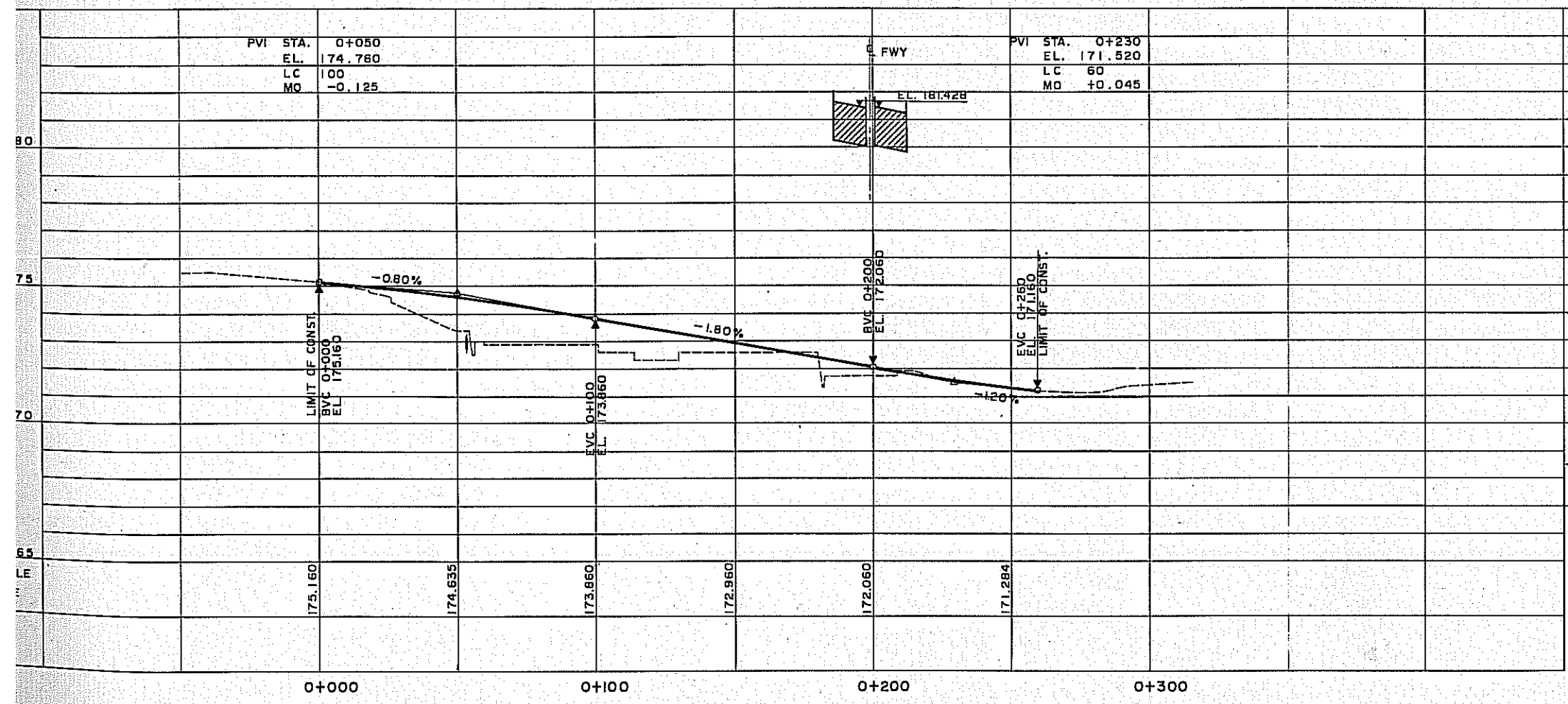
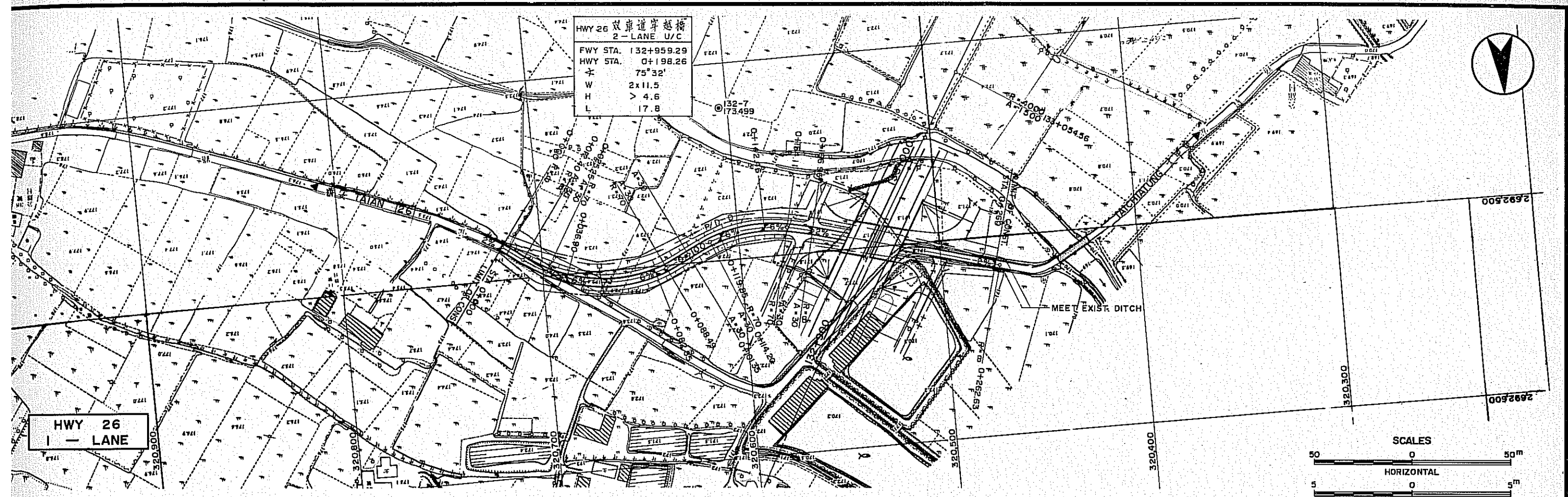

修正 REVISIONS	
項目 ITEM	日期 DATE

PROJECT 60
 交通部台灣區高速公路工程局
 TAIWAN AREA FREEWAY CONSTRUCTION BUREAU
 中華民國 REPUBLIC OF CHINA
 南北高速公路 NORTH-SOUTH FREEWAY
 苗栗台中段 MIAOLI-TAICHUNG SECTION
 平面及縱面 PLAN AND PROFILE
 HWY 26 AT FWY STA. 132+959.29
 中華顧問工程司 CHINA ENGINEERING CONSULTANTS, INC.
 日期 DATE AUG. 74 出圖 SCALE AS SHOWN 圖號 SHEET F-41

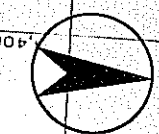

HWY 37 單車道跨越橋
 1-LANE O/C
 FWY STA. 134+593.90
 HWY STA. 0+330.39
 A 109°26'49"
 W 6.5
 H > 50
 L 498

排水箱
 DRAINAGE BOX
 HWY STA. 0+480.50
 A 115°
 W 2x20
 H 1.7
 L 220

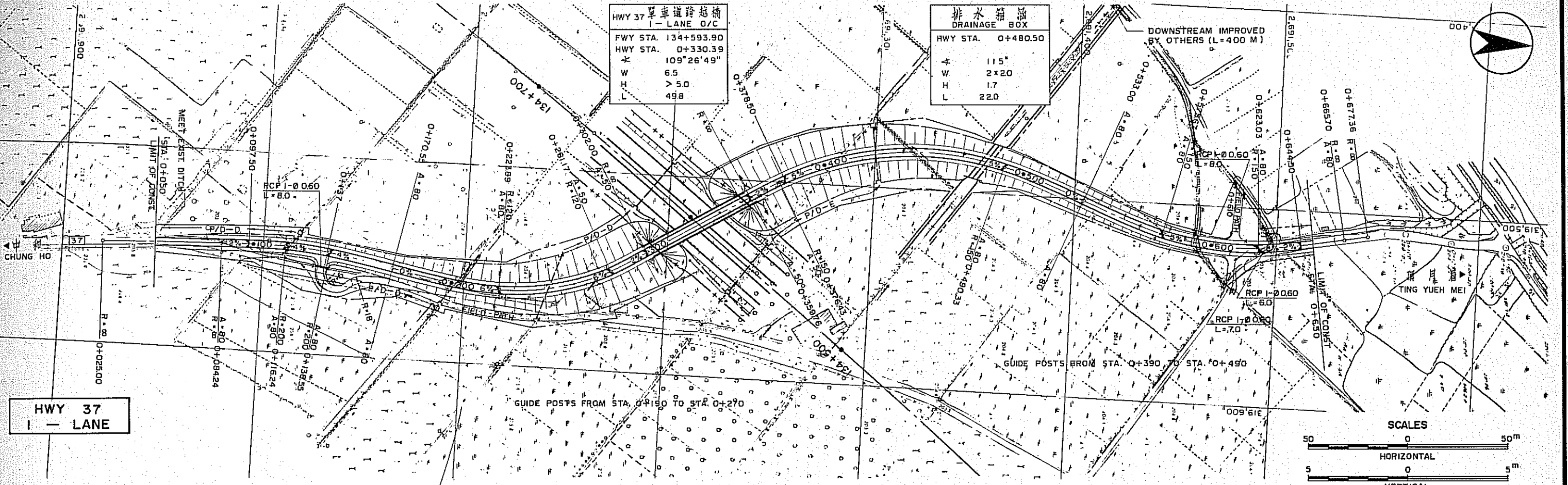

HWY 37
 1-LANE

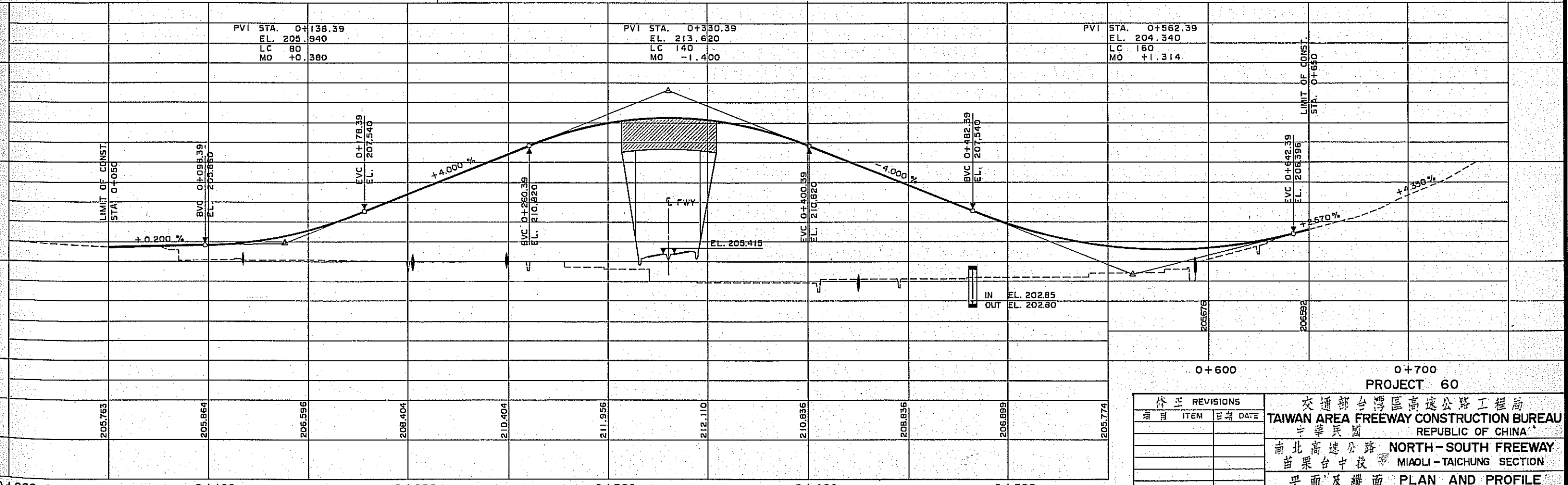
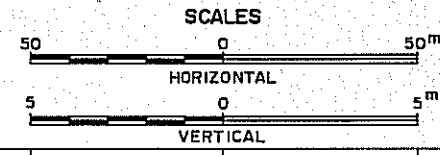

REV. NO.	REVISIONS	DATE

交通部台灣區高速公路工程局
 TAIWAN AREA FREEWAY CONSTRUCTION BUREAU
 中華民國
 南北高速公路 NORTH-SOUTH FREEWAY
 苗栗台中段 MIAOLI-TAICHUNG SECTION
 平面及縱面 PLAN AND PROFILE
 HWY 37 AT FWY STA. 134+593.90
 中華顧問工程司 CHINA ENGINEERING CONSULTANTS, INC.
 日期 DATE AUG. '74 比例 SCALE AS SHOWN 圖號 SHEET F-42

排水箱涵 DRAINAGE BOX	
HWY STA.	0+062
A	54°
W	2.0
H	1.5
L	18.0

HWY 132 雙車道跨橋 2-LANE O/C	
FWY STA.	135+864.91
HWY STA.	0+315.68
A	76°24'17"
W	12.5
H	> 5.0
L	56.0

排水箱涵 DRAINAGE BOX	
HWY STA	0+515
A	117°
W	2x2.0
H	1.5
L	30.7

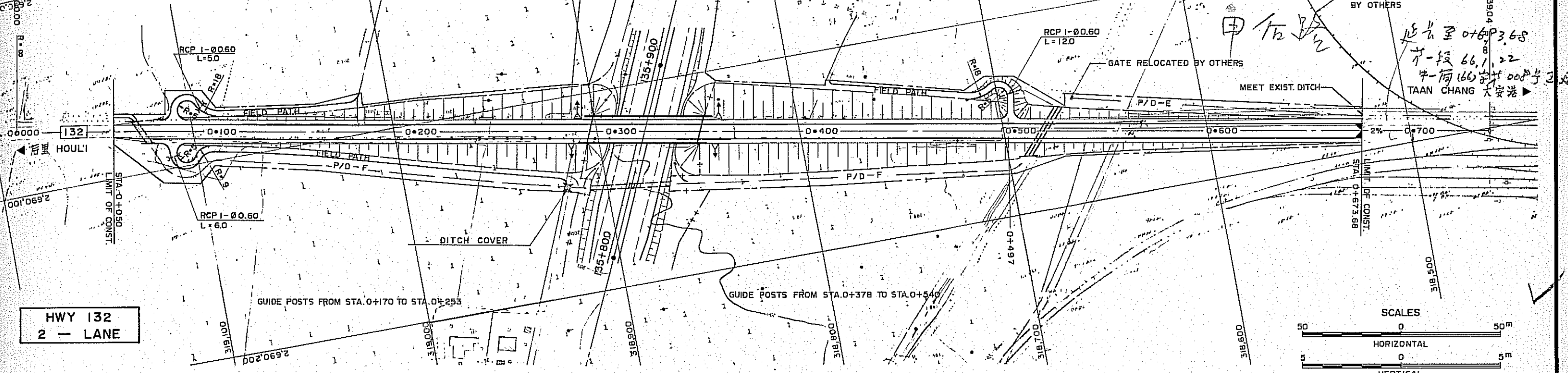
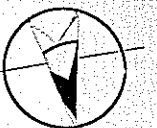

HWY 132
2-LANE

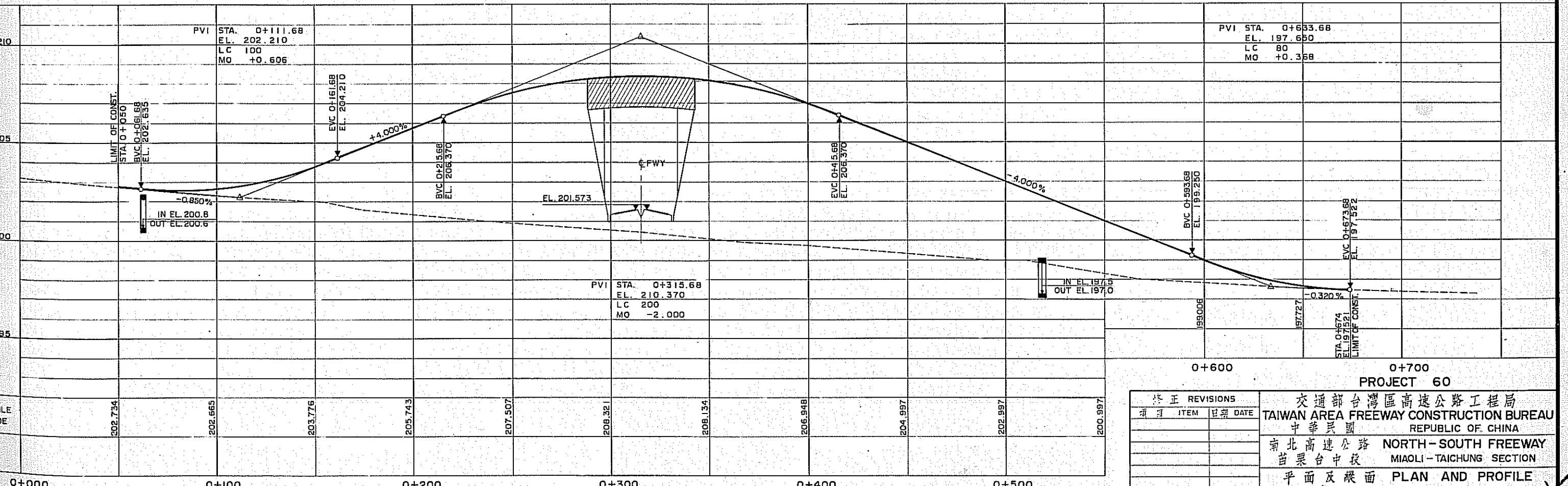
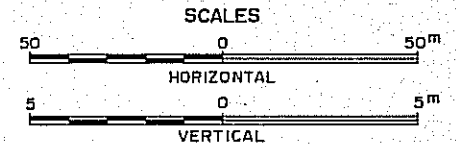

REVISIONS	
NO.	DATE

交通部台灣區高速公路工程局
TAIWAN AREA FREEWAY CONSTRUCTION BUREAU
中華民國
南北高速公路 NORTH-SOUTH FREEWAY
苗栗台中段 MIAOLI-TAICHUNG SECTION
平面及縱面 PLAN AND PROFILE
HWY 132 AT FWY STA. 135+864.91
中華顧問工程司 CHINA ENGINEERING CONSULTANTS, INC.
DATE AUG. '74 SCALE AS SHOWN SHEET F-43



HWY 36 雙車道跨橋	
2-LANE O/C	
FWY STA.	136+177.38
HWY STA.	0+304.45
A	99' 57' 46"
W	11.0
H	5.0
L	49.8

排水箱涵	
DRAINAGE BOX	
HWY STA.	0+576
A	104'
W	2 x 2.0
H	1.5
L	14.3

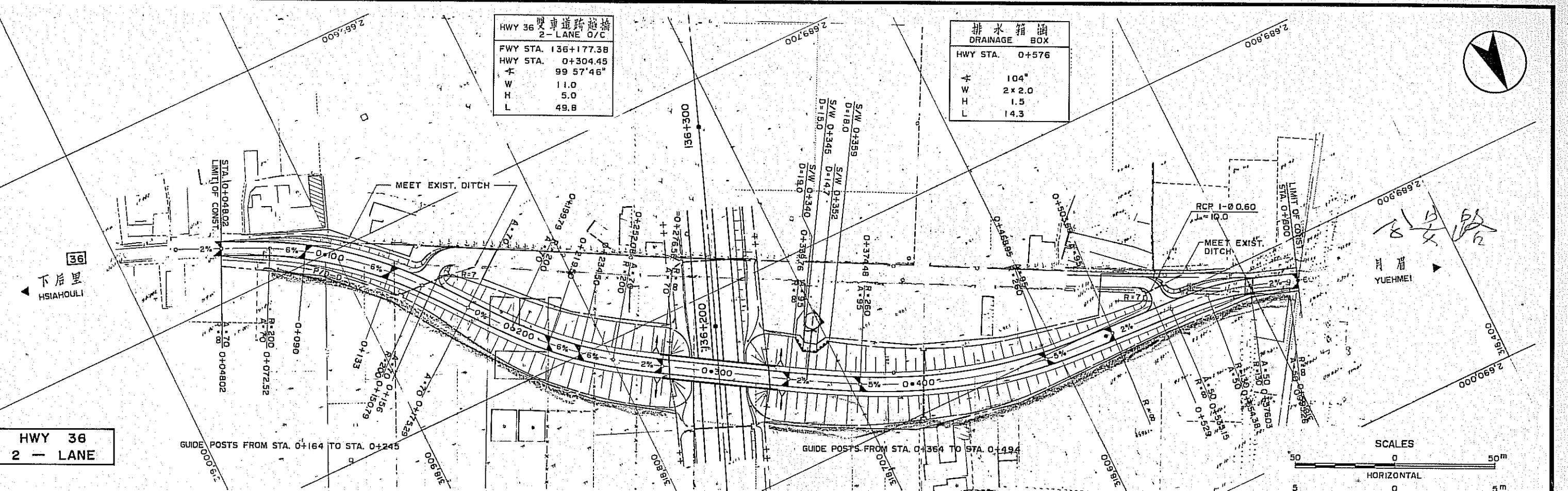

HWY 36
2 - LANE

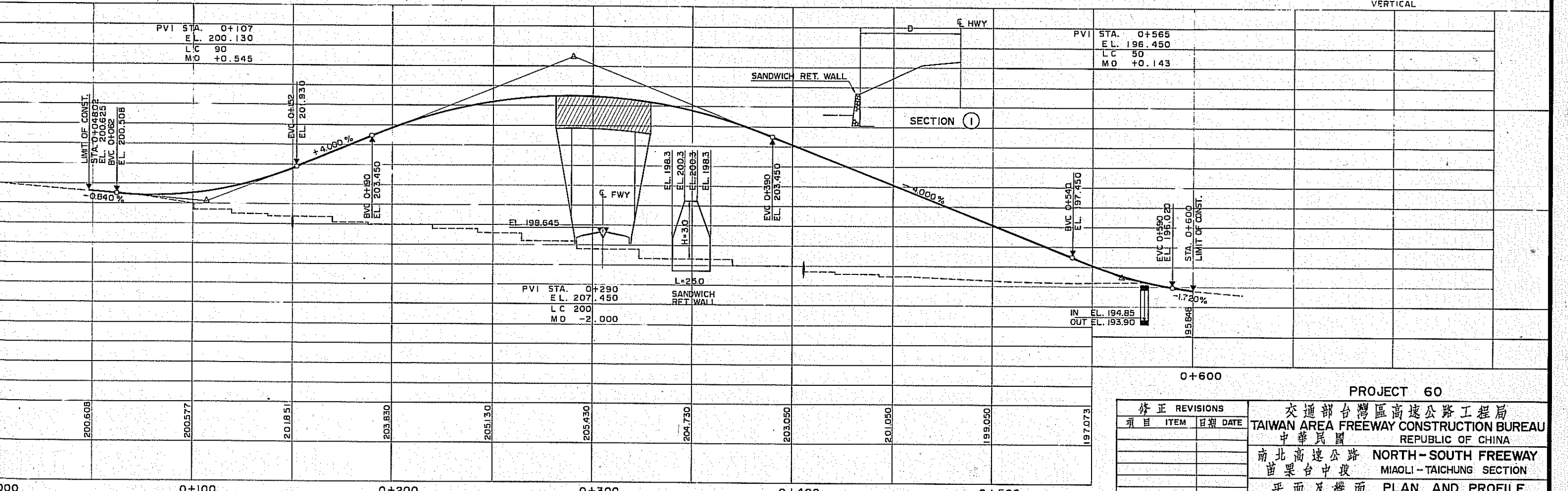
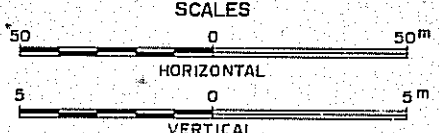

修正 REVISIONS		交通部台灣區高速公路工程局 TAIWAN AREA FREEWAY CONSTRUCTION BUREAU 中華民國 南北高速公路 NORTH-SOUTH FREEWAY 苗栗台中段 MIAOLI-TAICHUNG SECTION 平面及縱面 PLAN AND PROFILE HWY 36 AT FWY STA. 136+177.38 中華顧問工程司 CHINA ENGINEERING CONSULTANTS, INC. 日期 DATE AUG '74 比例 SCALE A5 SHOWN 圖號 SHEET F-44
項目 ITEM	日期 DATE	

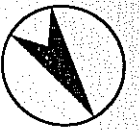

HWY 31 單車道跨越橋
1-LANE O/C
FWY STA. 137+145.98
HWY STA. 0+287.35
+ 105°34'34"
W 6.5
H > 5.0
L 49.8

排水箱涵
DRAINAGE BOX
HWY STA. J+427
+ 110°
W 5x4.0
H 3.0
L 19.7

茶寮潭
64.3.18
H261-29-8(32)
准許築路

HWY 31
1-LANE

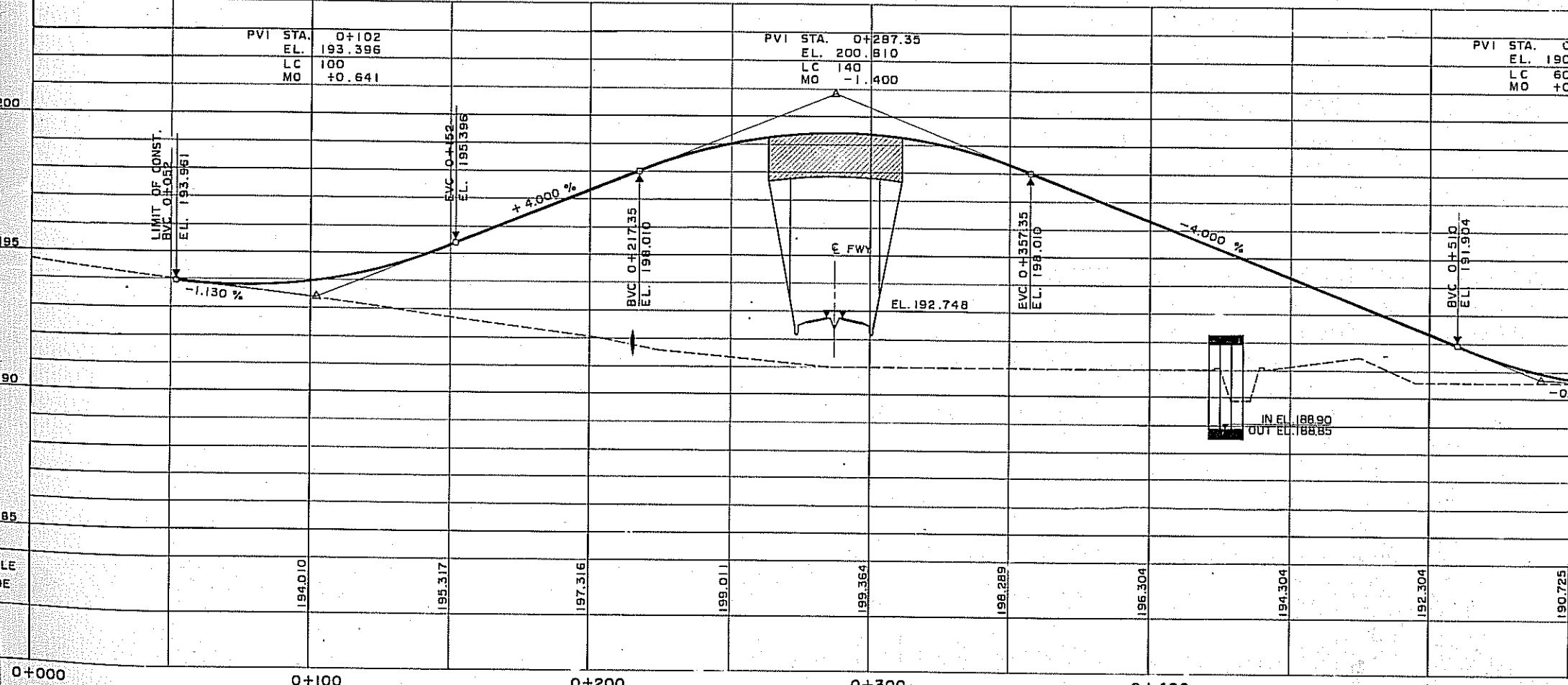
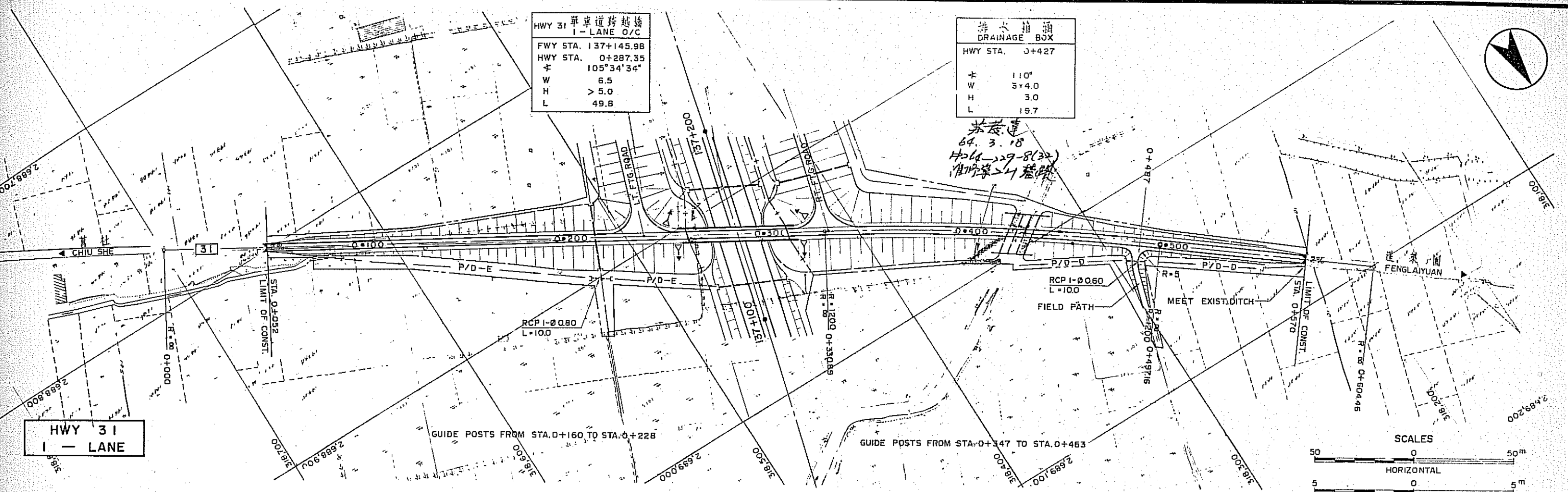
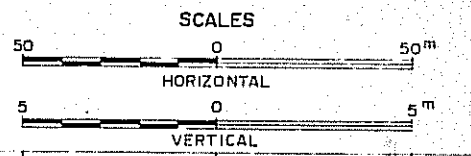

REVISIONS		
NO.	ITEM	DATE

PROJECT 60

交通部台灣區高速公路二程局
TAIWAN AREA FREEWAY CONSTRUCTION BUREAU
中華民國
台北高速公路 NORTH-SOUTH FREEWAY
苗栗台中段 MIAOLI-TAICHUNG SECTION

平面及縱面 PLAN AND PROFILE
HWY 31 AT FWY STA. 137+145.98

中華顧問工程司 CHINA ENGINEERING CONSULTANTS, INC.
DATE AUG. '74 SCALE AS SHOWN SHEET F-45

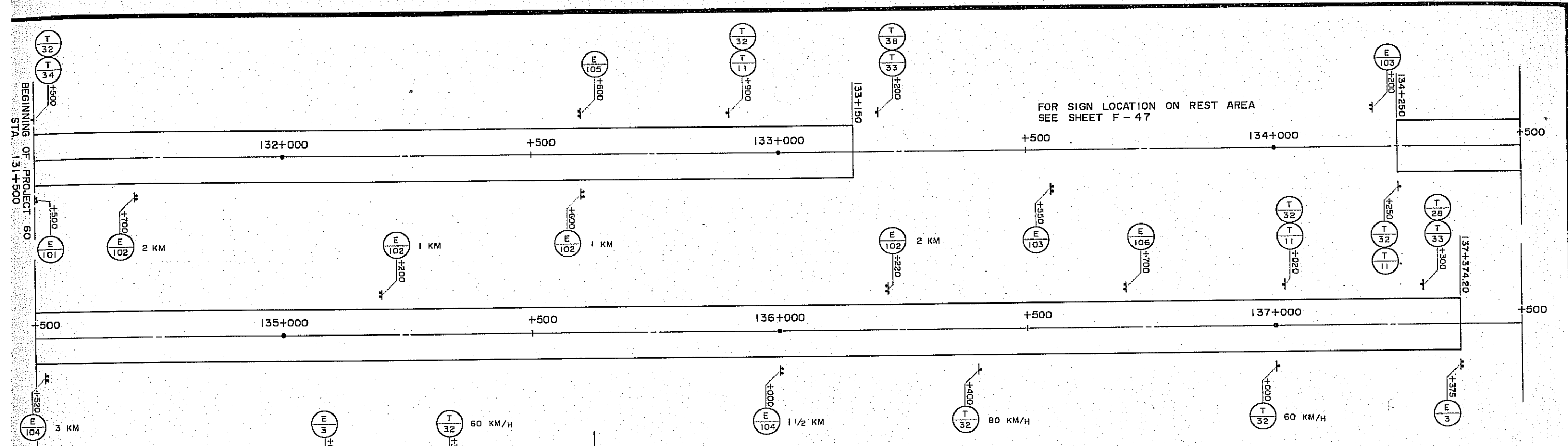

FOR SIGN LOCATION ON REST AREA
SEE SHEET F-47

FOR SIGN LOCATION ON TOLL PLAZA
SEE SHEET T-4 (TOLL PLAZA)

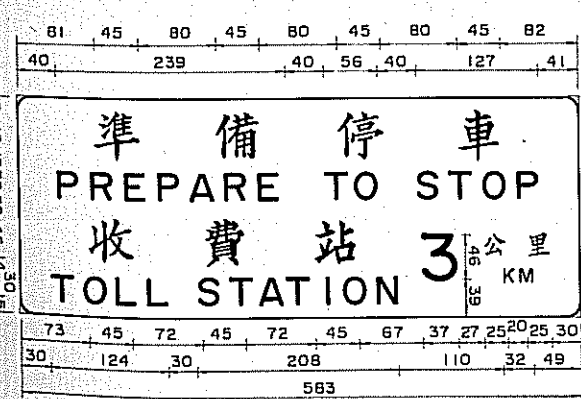

E-104

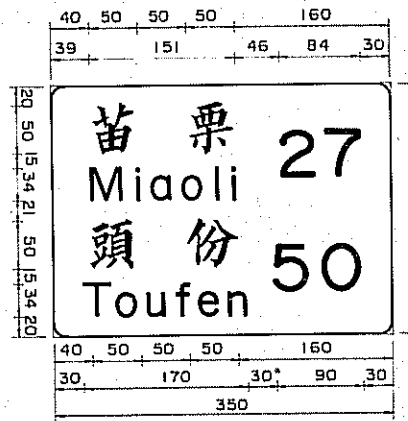

E-105

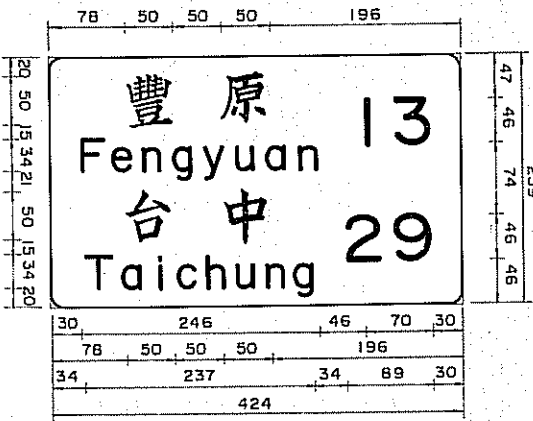

E-101

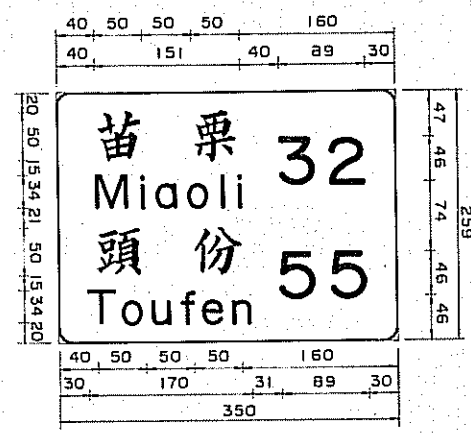

E-106

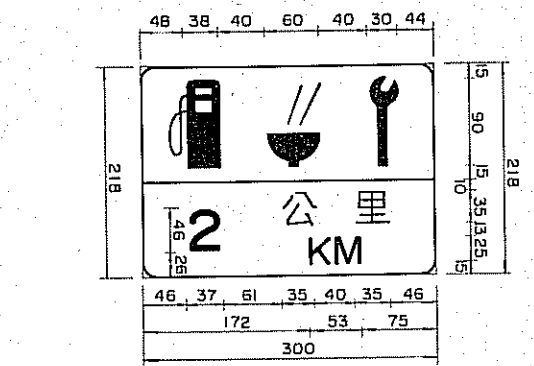

E-102

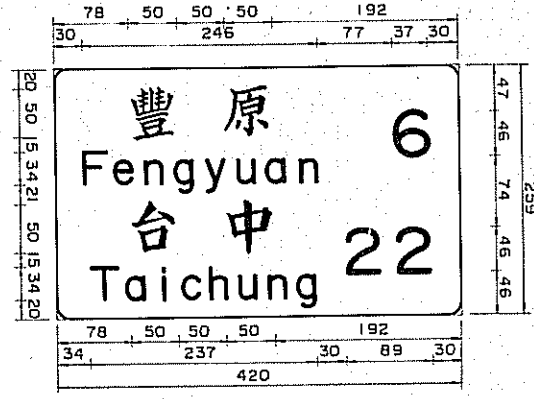

E-107

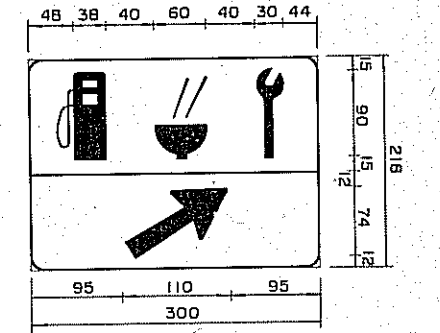

E-103

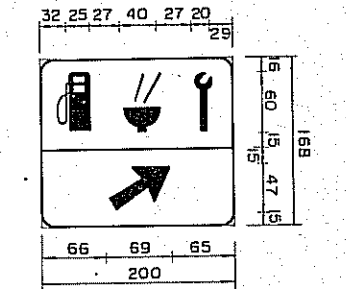

E-108

說明：
1. 牌面尺寸以公分計

修正 REVISIONS	
項目 ITEM	日期 DATE

交通部台灣區高速公路工程局
TAIWAN AREA FREEWAY CONSTRUCTION BUREAU
中華民國
南北高速公路 NORTH-SOUTH FREEWAY
苗栗台中段 MIAOLI-TAICHUNG SECTION
標誌牌面及位置 SIGN FACE DETAILS & LOCATION
中華顧問工程司 CHINA ENGINEERING CONSULTANTS, INC.
日期 DATE AUG. 74 比例 SCALE NONE 圖號 SHEET F-46

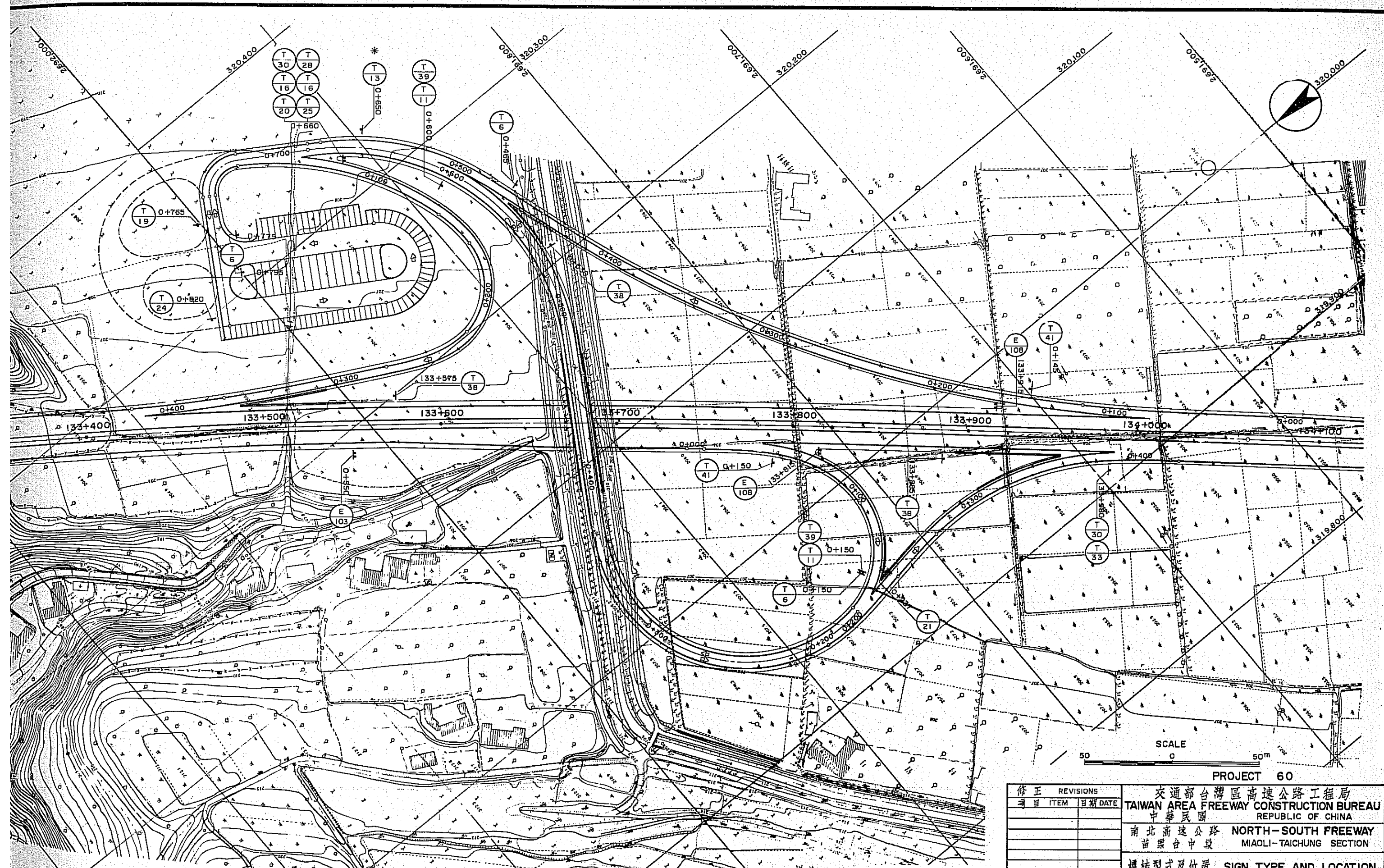

說明：*最高速率 10 km/h

修正	REVISIONS	項目	ITEM	日期	DATE

交通部台灣區高速公路工程局
 TAIWAN AREA FREEWAY CONSTRUCTION BUREAU
 中華民國 REPUBLIC OF CHINA
 南北高速公路 NORTH-SOUTH FREEWAY
 苗栗台中段 MIAOLI-TAICHUNG SECTION
 標誌型式及位置 SIGN TYPE AND LOCATION
 中華顧問工程司 CHINA ENGINEERING CONSULTANTS, INC.
 日期 DATE AUG. '74 比例 SCALE NONE 圖號 SHEET F-47

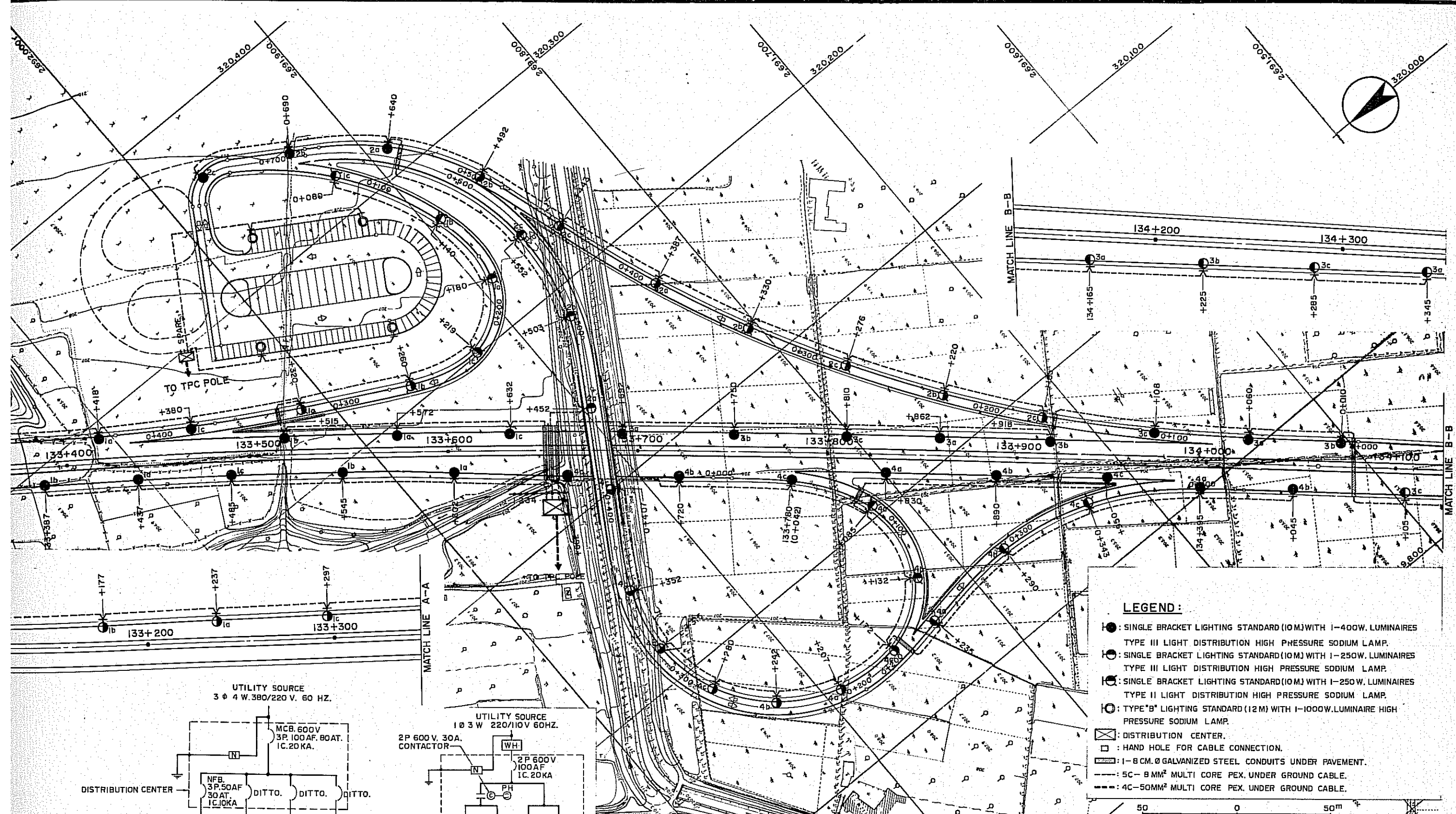
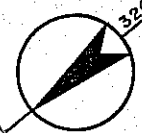

LEGEND:

- : SINGLE BRACKET LIGHTING STANDARD (10 M) WITH 1-400W. LUMINAIRES TYPE III LIGHT DISTRIBUTION HIGH PRESSURE SODIUM LAMP.
- : SINGLE BRACKET LIGHTING STANDARD (10 M) WITH 1-250W. LUMINAIRES TYPE III LIGHT DISTRIBUTION HIGH PRESSURE SODIUM LAMP.
- : SINGLE BRACKET LIGHTING STANDARD (10 M) WITH 1-250W. LUMINAIRES TYPE II LIGHT DISTRIBUTION HIGH PRESSURE SODIUM LAMP.
- : TYPE "B" LIGHTING STANDARD (12 M) WITH 1-1000W. LUMINAIRE HIGH PRESSURE SODIUM LAMP.
- ⊠: DISTRIBUTION CENTER.
- : HAND HOLE FOR CABLE CONNECTION.
- : 1-8 CM. Ø GALVANIZED STEEL CONDUITS UNDER PAVEMENT.
- - -: 5C- 8 MM² MULTI CORE PEX. UNDER GROUND CABLE.
- - -: 4C- 50MM² MULTI CORE PEX. UNDER GROUND CABLE.

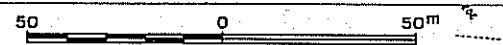

UTILITY SOURCE
3 φ 4 W. 380/220 V. 60 HZ.

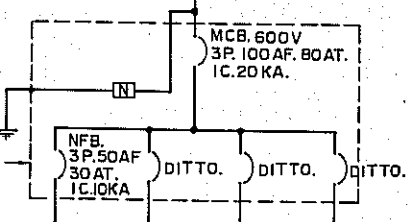

CKT. NO.	1	2	3	4
400 W. LUMINAIRE	10	3	8	8
250 W. LUMINAIRE	11	10	5	12
LOAD (KVA)	8.78	4.87	5.76	8.09
3 φ AMP.	13.3	7.39	8.75	12.3
CONDUCTOR SIZE	8MM ²	8MM ²	8MM ²	8MM ²
VOLTAGE DROP(%)	3.23	3.6	4.4	3.9
TOTAL KVA.	27.49 KVA.			

UTILITY SOURCE
1 φ 3 W 220/110V 60HZ.

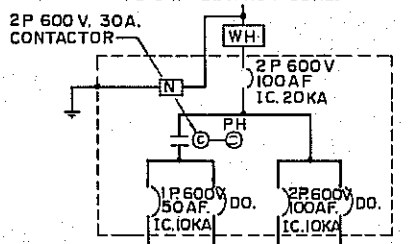

CKT. NO.	1	2	3	4
1000W. LUMINAIRE	2	2	3	SPARE
KW	1200	1200		
AMPS.	5.45	5.45		
CONDUCTOR	8MM ²	8MM ²		

NOTE:

EACH LUMINAIRE SHALL BE PROTECTED BY D-FUSE TYPE(E-27IR6A.VD.500V.AS MANUFACTURED BY THE BOGENSCHUTZ CORPORATION OF GERMANY OR EQUIVALENT.) ON THE LINE SIDE OF THE BALLAST, AND LOCATED IN THE TRANSFORMER BASE. D-FUSE SOCKET SHALL BE WHITE PORCELAIN METAL PARTS MADE OF COPPER NICKEL-PLATED, WITH BLACK BAKELITE COVER AND MOUNTING ON INSULATING PLATE. LOAD SIDE OF D-FUSE SHALL BE 5.5MM CU CONC. LEADING UPWARD INSIDE THE POLE TO THE LUMINAIRE. THE RATING AMPERE FOR 1000W LUMINAIRE SHALL BE 10 A.

SCALE PROJECT 60

修正 REVISIONS	項目 ITEM	日期 DATE

交通部台灣區高速公路工程局
TAIWAN AREA FREEWAY CONSTRUCTION BUREAU
中華民國
REPUBLIC OF CHINA
南北高速公路 NORTH-SOUTH FREEWAY
苗栗台中段 MIAOLI-TAICHUNG SECTION
照明設施 REST AREA LIGHTING
休息站
中華顧問工程司 CHINA ENGINEERING CONSULTANTS, INC.
日期 DATE AUG. 74 比例 SCALE AS SHOWN 圖號 SHEET F-4B

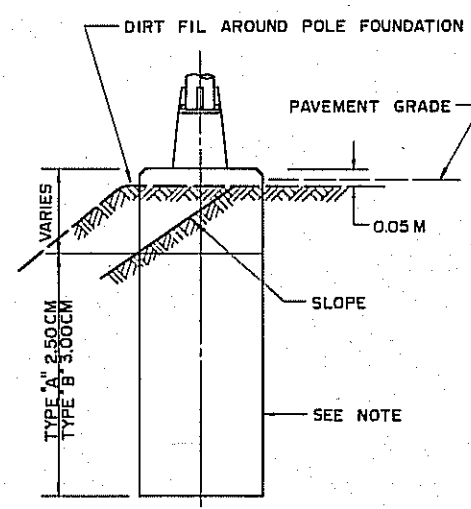
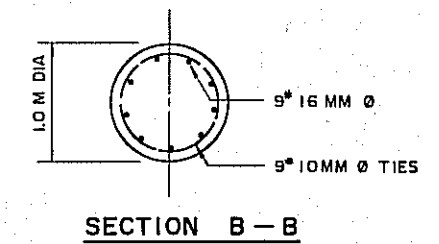
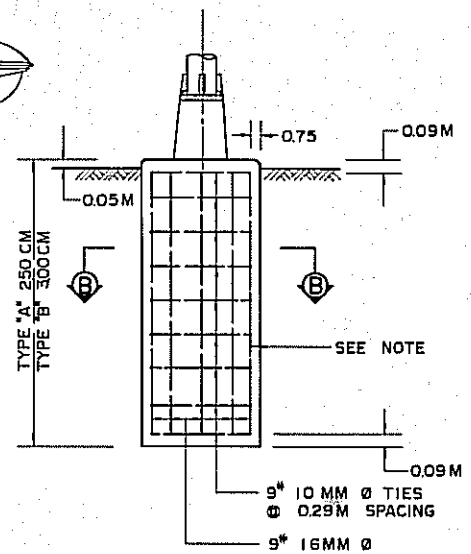
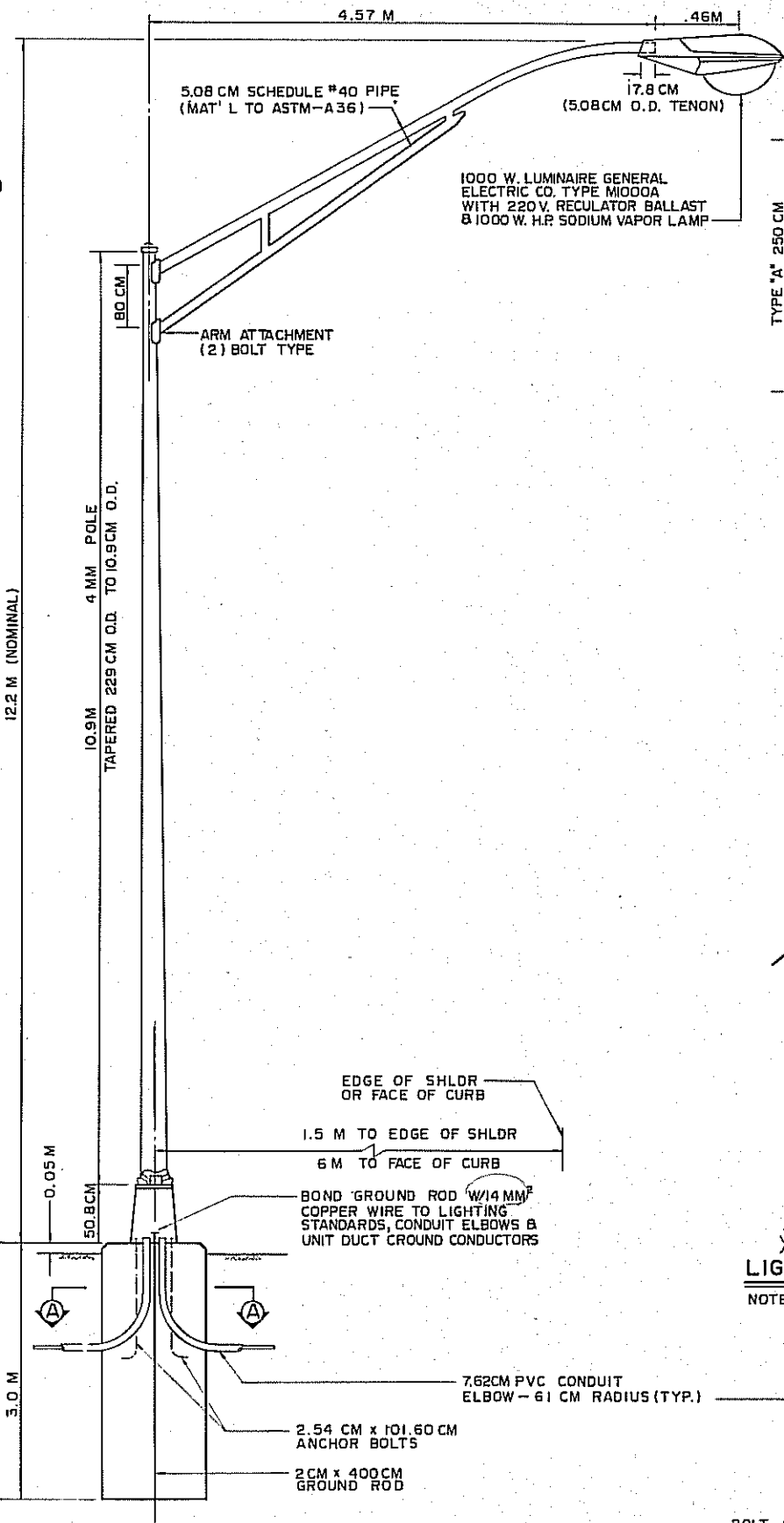
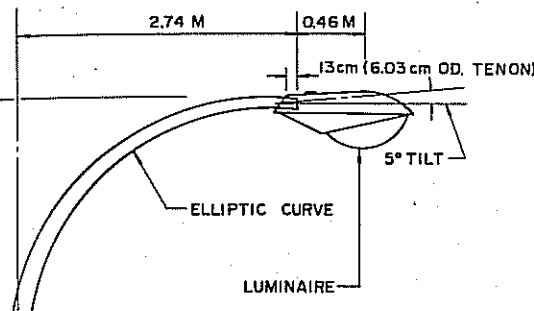

灯柱基础
LIGHTING STANDARD FOUNDATION

NOTE: LENGTH AND NUMBER OF RE-BARS SHALL VARY WITH THE LENGTH OF FOUNDATION

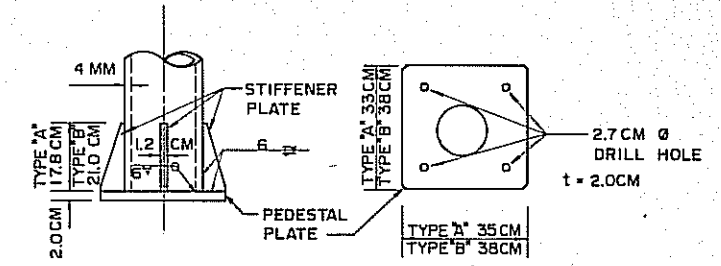
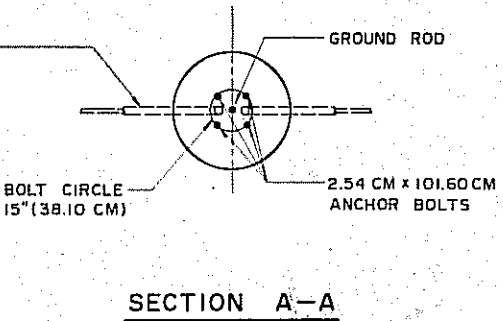

基台頂部
ANCHOR BASE DETAIL
LIGHTING STANDARDS

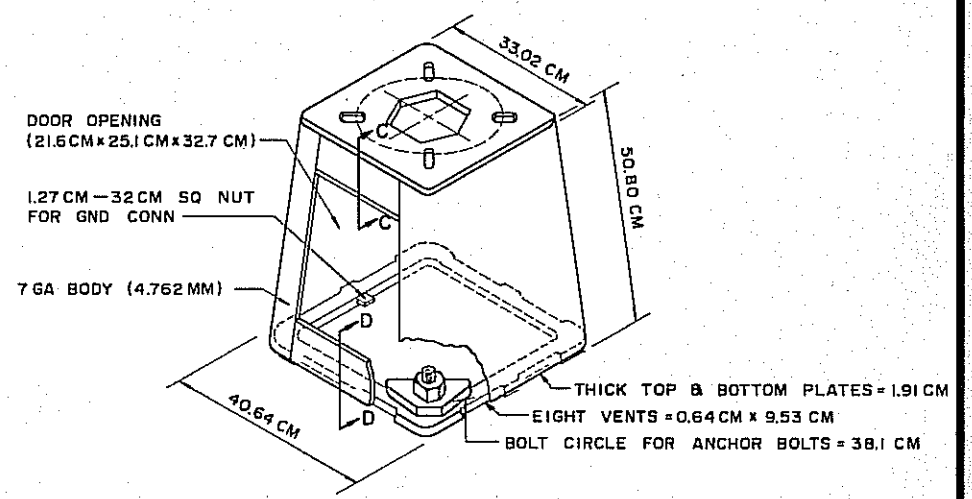

灯柱基台詳圖
TRANSFORMER BASE DETAILS

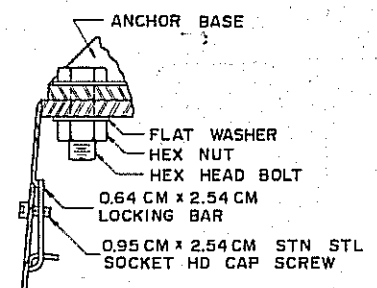

SECTION "C-C"

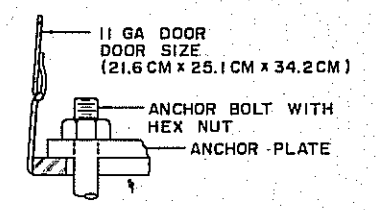

SECTION "D-D"

PROJECT 60

修正	REVISIONS	項目	ITEM	日期	DATE

交通部台灣區高速公路工程局
TAIWAN AREA FREEWAY CONSTRUCTION BUREAU
中華民國
REPUBLIC OF CHINA
南北高速公路 NORTH-SOUTH FREEWAY
苗栗台中段 MIAOLI-TAICHUNG SECTION
照明灯柱及基礎詳圖
LIGHTING STANDARDS AND POST DETAILS
中華顧問工程司 CHINA ENGINEERING CONSULTANTS, INC.
日期 DATE AUG. '74 比例 SCALE NOT TO SCALE 圖號 DRAWING NO. APPENDIX F-49

A型單灯柱詳圖
TYPE A

B型單灯柱詳圖
TYPE B

SECTION A-A

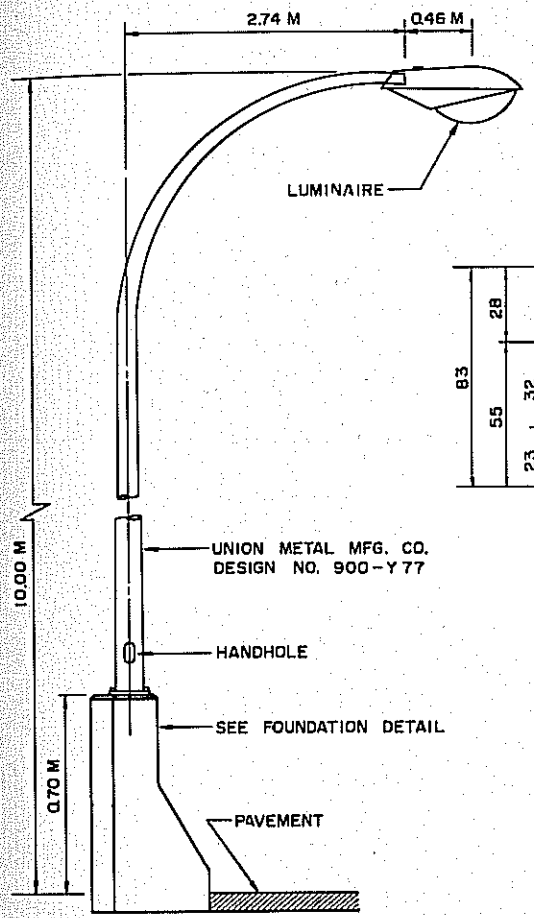

橋上燈柱
LIGHTING STANDARD ON PARAPET

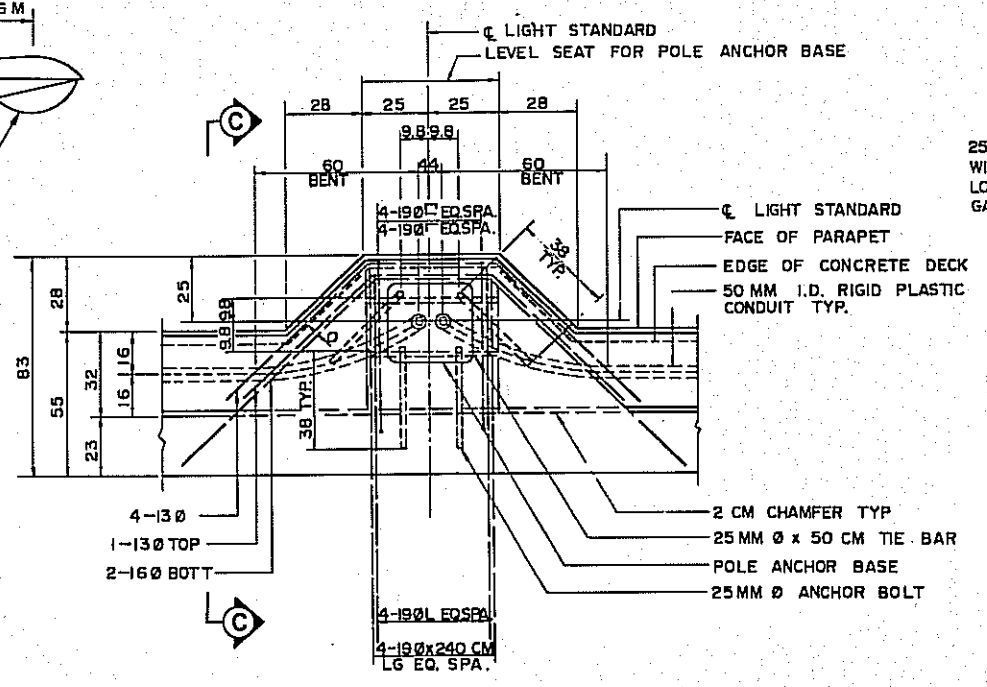

PLAN
AT PARAPET

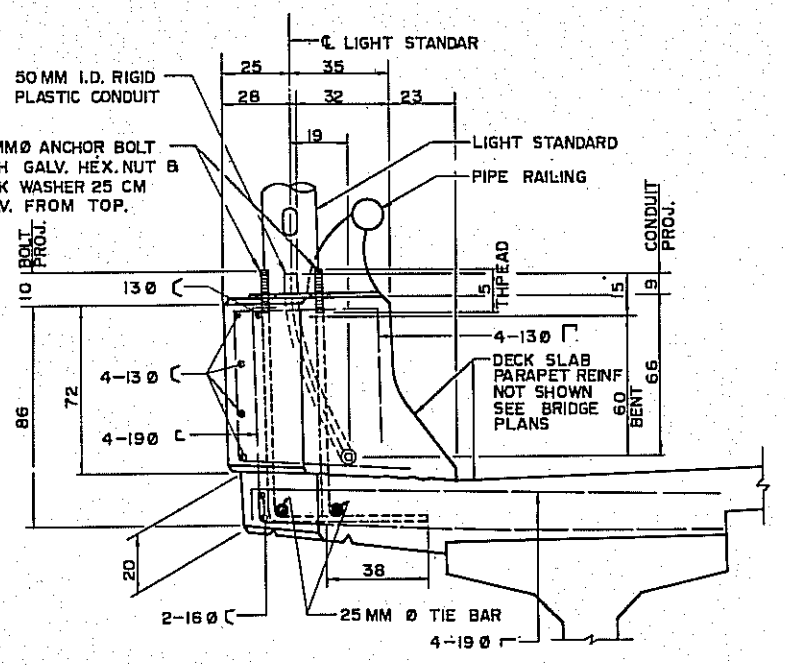

SECTION C-C

NOTE: DIMENSIONS ARE IN CM UNLESS OTHERWISE NOTED

橋上燈柱基架
FOUNDATION DETAIL ON PARAPET

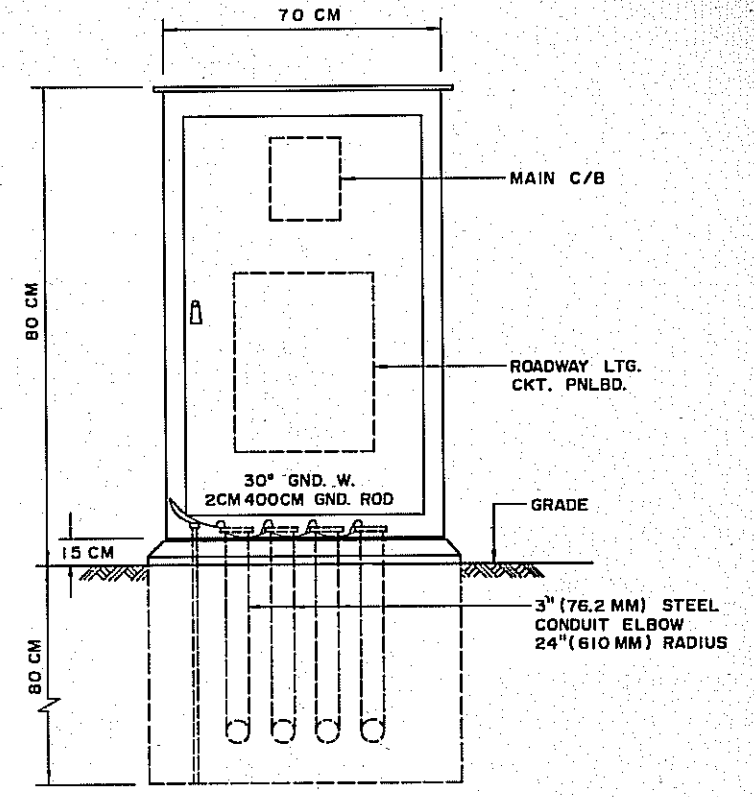

配電箱詳圖
DISTRIBUTION CENTER

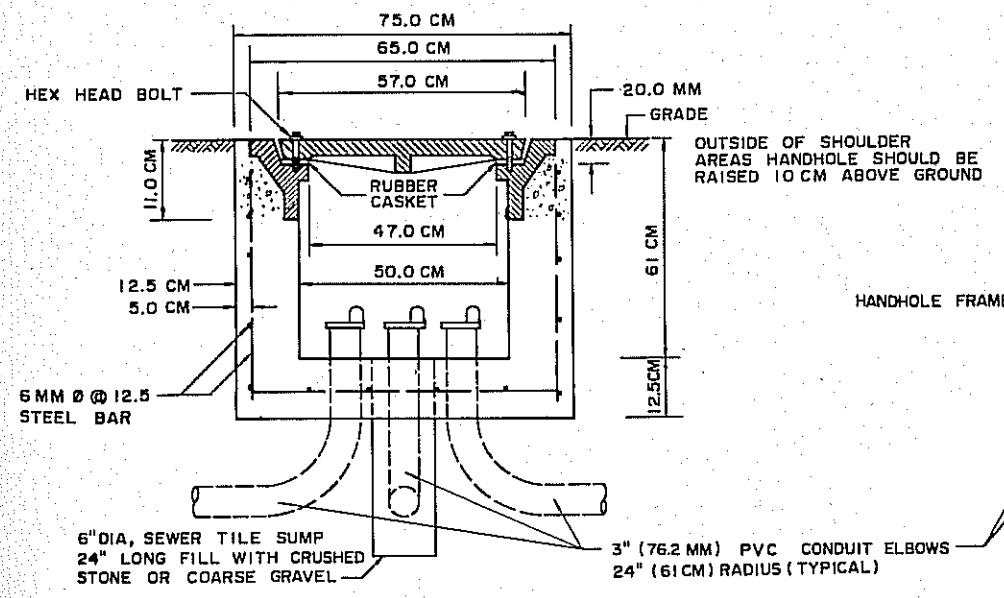

手孔剖面
HANDHOLE SECTION A-A

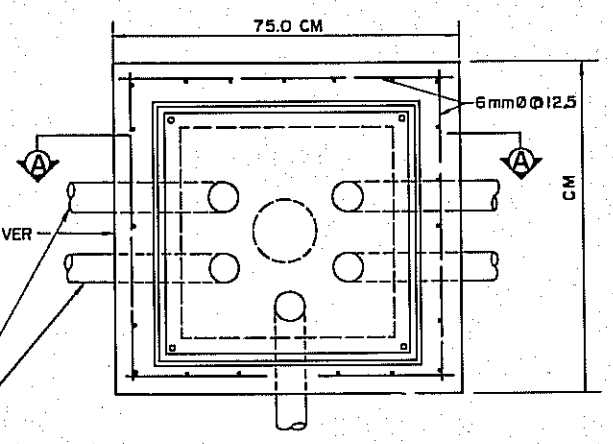

標準手孔詳圖
TYPICAL HANDHOLE DETAIL

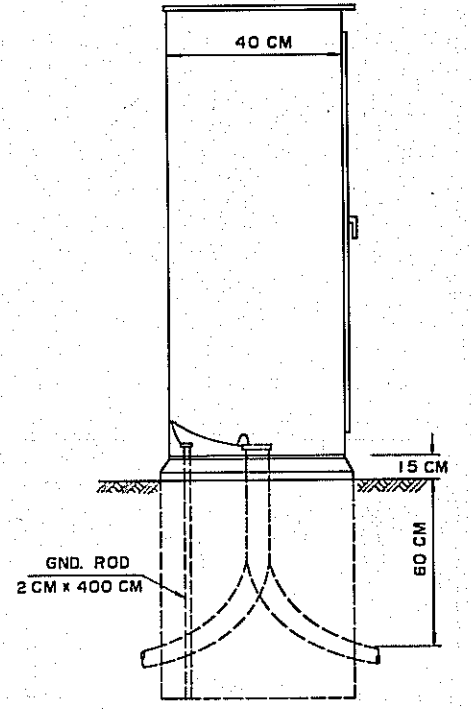

修正	REVISIONS	項目	ITEM	日期	DATE

交通部台灣區高速公路工程局
TAIWAN AREA FREEWAY CONSTRUCTION BUREAU
中華民國 REPUBLIC OF CHINA
南北高速公路 NORTH-SOUTH FREEWAY
苗栗台中段 MIAOLI-TAICHUNG SECTION
橋上燈柱手孔及配電箱詳圖
LIGHTING DETAILS
中華顧問工程司 CHINA ENGINEERING CONSULTANTS, INC.
日期 DATE AUG. '74 比例 SCALE NOT TO SCALE 圖號 APPENDIX F-50

PROJECT 60

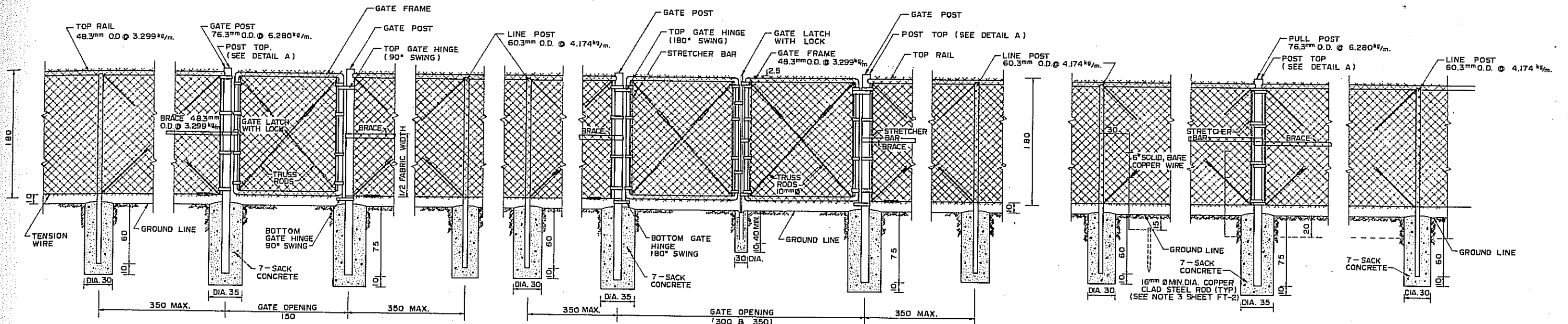

單柵門裝置
SINGLE GATE ARRANGEMENT

雙柵門裝置
DOUBLE GATE ARRANGEMENT

承拉支柱裝置
PULL POST ARRANGEMENT

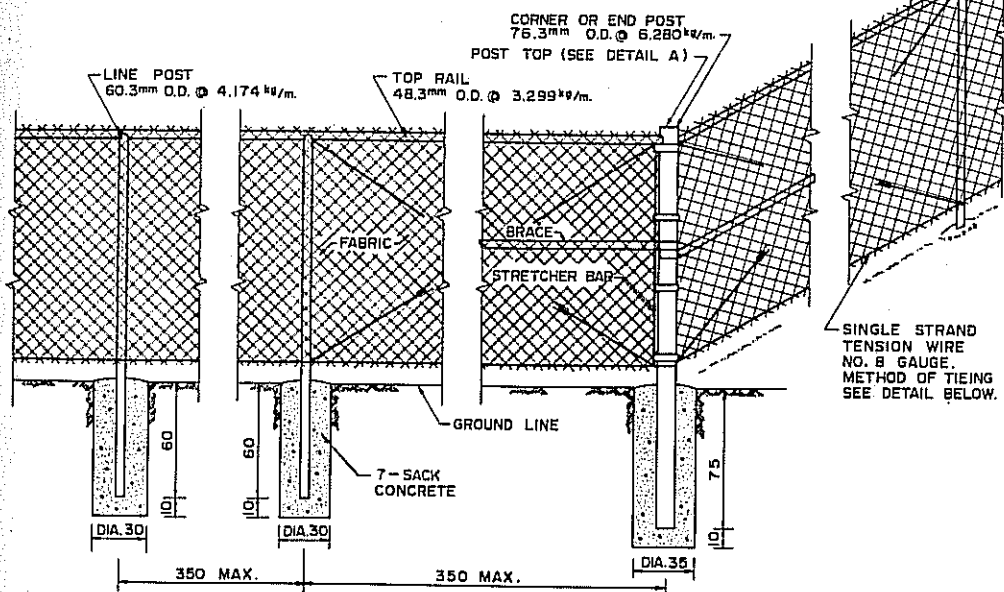

角柱或端柱裝置
CORNER OR END POST ARRANGEMENT

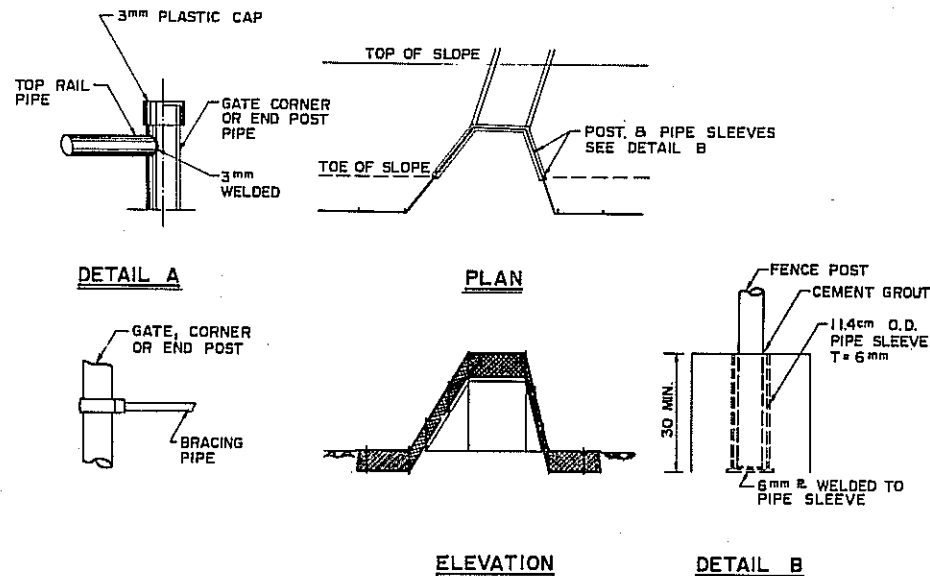

撐桿與支柱接合
METHOD OF BRACING
CONNECTED TO POST

端牆柵欄設置
FENCE INSTALLATION
AT HEADWALLS

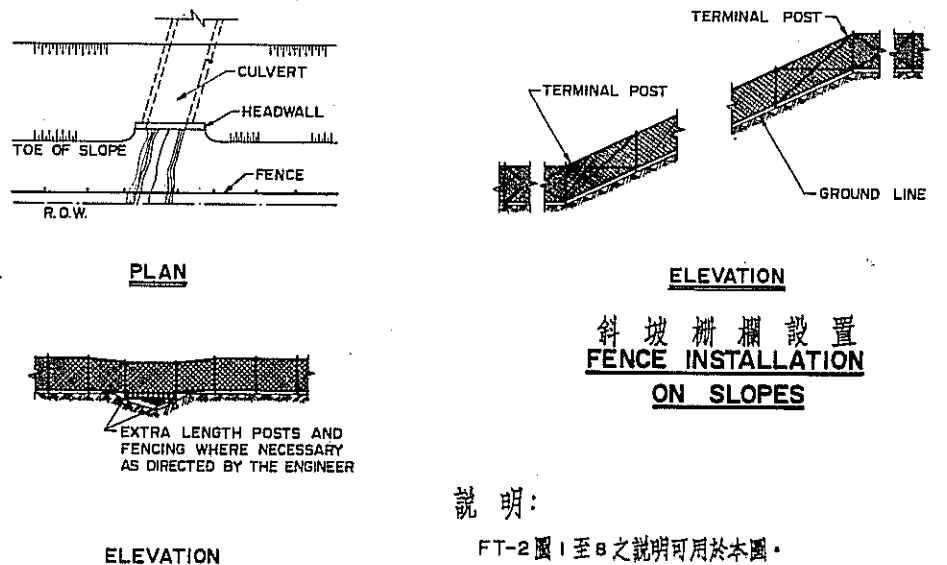

柵欄跨越溝渠設置
FENCE INSTALLATION
OVER DITCHES

斜坡柵欄設置
FENCE INSTALLATION
ON SLOPES

支柱裝置
LINE POST
ARRANGEMENT

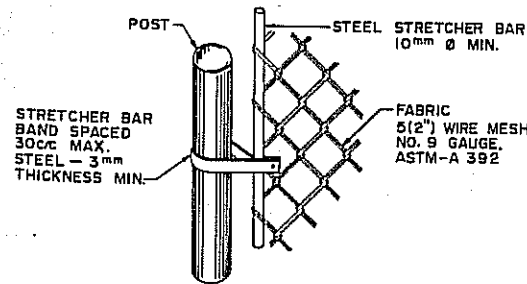

撐架桿與支柱扣繫
METHOD OF FASTENING
STRETCHER BAR TO POST

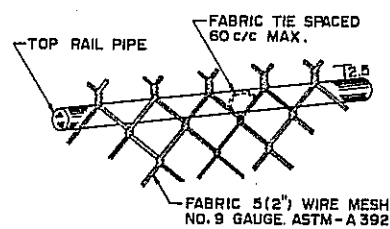

編織網與頂管結繫
METHOD OF TYING
FABRIC TO PIPE

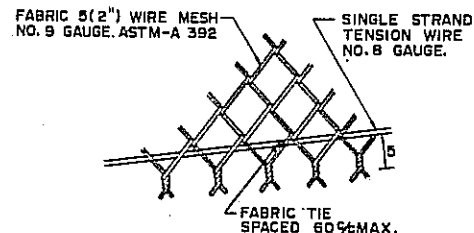

編織網與拉力線結繫
METHOD OF TYING
FABRIC TO TENSION WIRE

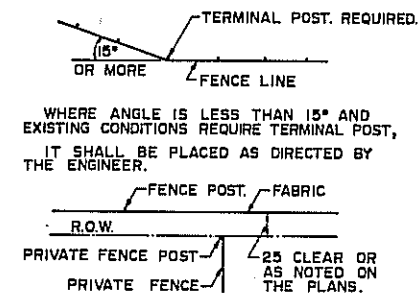

與私設柵欄關係圖
PRIVATE FENCE TERMINAL

說明：
FT-2圖1至8之說明可用於本圖。

NOTES:
ALL NOTES "1" THRU "8" LISTED ON SHEET FT-2 FOR WIRE MESH FENCING ARE ALSO APPLICABLE TO CHAIN LINK FENCING, SHEET FT-1.

修正 REVISIONS		FREEWAY STANDARD DETAILS	
項目 ITEM	日期 DATE	交通部台灣區高速公路工程局 TAIWAN AREA FREEWAY CONSTRUCTION BUREAU 中華民國 REPUBLIC OF CHINA	
		南北高速公路 苗栗台中段 NORTH-SOUTH FREEWAY MIAOLI-TAICHUNG SECTION	
		鏈式鐵絲網柵欄 CHAIN LINK FENCE	
		中華顧問工程司 CHINA ENGINEERING CONSULTANTS, INC.	
		日期 DATE AUG. '74 比例 SCALE NONE 圖號 APPENDIX FT-1	

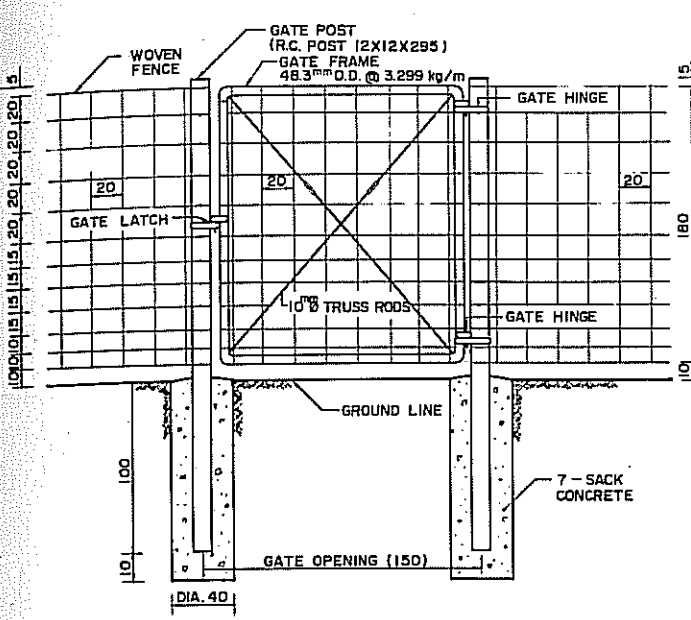

單柵門裝置
SINGLE GATE ARRANGEMENT

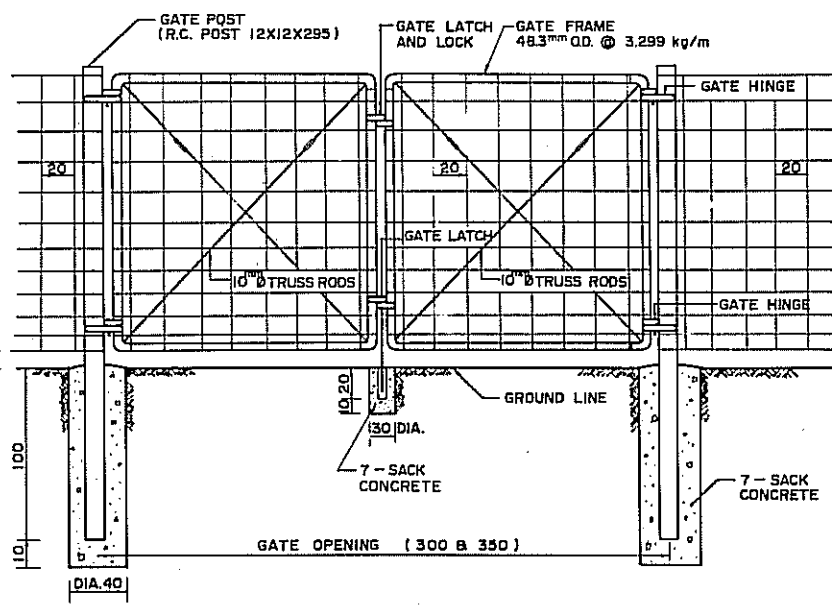

雙柵門裝置
DOUBLE GATE ARRANGEMENT

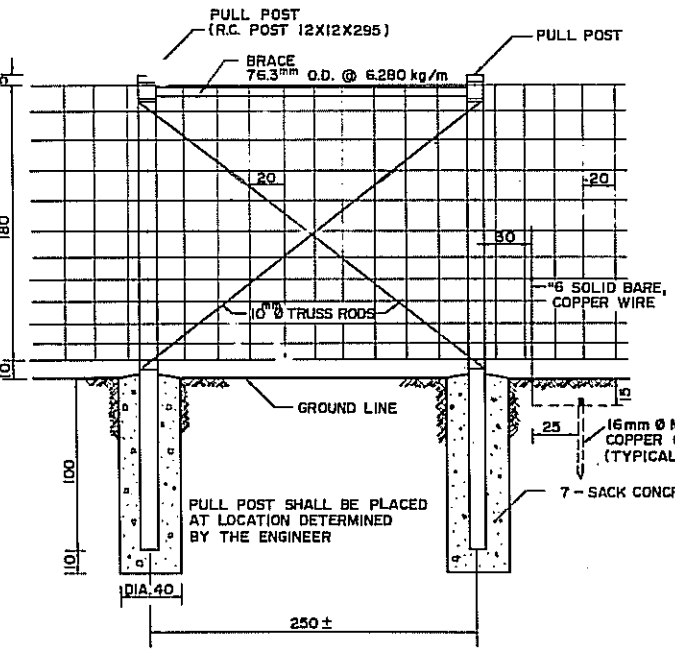

承拉支柱裝置
PULL POST ARRANGEMENT

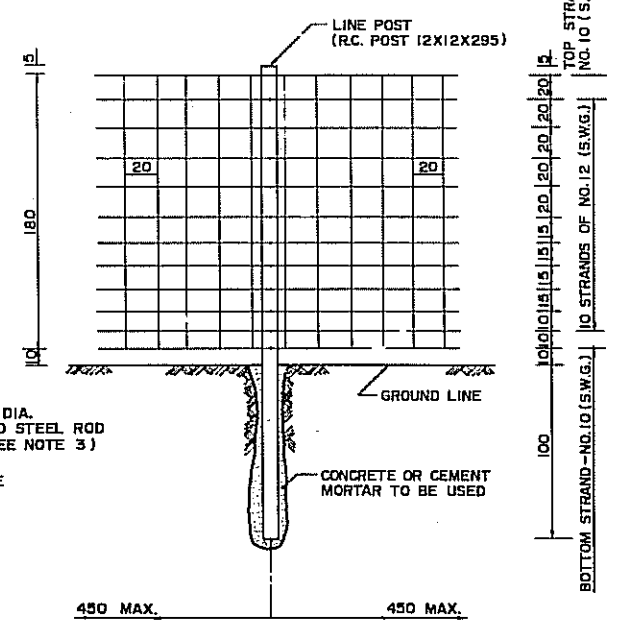

支柱裝置
LINE POST ARRANGEMENT

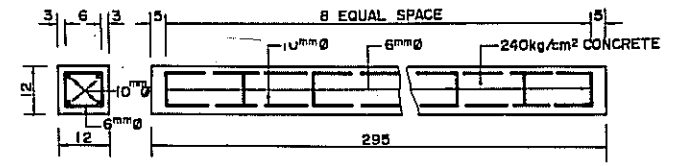

鋼筋混凝土支柱詳圖
R.C. POST DETAIL

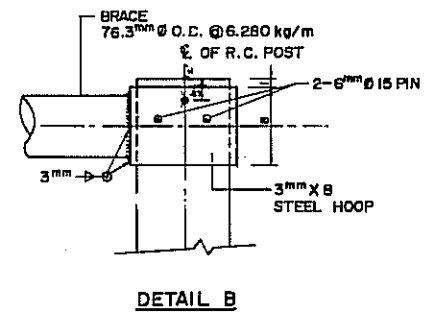

DETAIL B

說明:

- 防銹處理: 使用之鋼管螺栓及附屬品皆需鍍鋅, 其表面鍍量, 每平方公尺不得少於360公克。
- 支撐及拉桿: 鐵絲網柵欄之端柱, 角柱及每間隔300公尺應裝設支撐及拉桿, 設置之位置或另需增設, 由工程師指定之。
- 避電地線: 在市鎮地區每隔200公尺, 郊區每隔400公尺連續之柵欄需埋設地線, 柵欄穿過電力線之下方及前後15公尺, 亦需埋設。
- 橋樑柵欄裝置: 柵欄終止於橋樑, 翼牆或橋墩處應妥為裝設, 務使牲畜及孩童不能穿越。
- 道涵柵欄裝置: 柵欄需於翼牆端部終止並妥為牢固。
- 箱涵柵欄裝置: 柵欄應終止於翼牆高度2公尺處, 倘翼牆高度不足2公尺時, 柵欄應連續設置, 跨越箱涵頂端, 參閱 FT-1。
- 柵欄裝於翼牆上, 需使用鋼管支柱。
- 所有尺寸除另有註明者外, 皆以公分計。

NOTES:

- RUST PREVENTION: ALL PIPES, BOLTS AND FITTINGS SHALL BE GALVANIZED WITH A ZINC COATING OF NOT LESS THAN 360 GRAM PER SQUARE METER OF SURFACE.
- BRACES: BRACES ARE RECOMMENDED AT CORNER POSTS, END POSTS AND 300 METER INTERVALS. BRACING AS NOTED OR ADDITIONAL BRACING WILL BE LEFT TO THE DISCRETION OF THE ENGINEER.
- PROTECTIVE ELECTRIC GROUNDING: CONTINUOUS FENCING 200 METER IN URBAN AREA AND 400 METER IN RURAL AREAS SHALL BE GROUNDED. FENCE UNDER POWER LINE SHALL BE GROUNDED UNDER THE POWER LINE AND 15 METERS ON EACH SIDE.
- TERMINALS AT BRIDGES: FENCING SHOULD BE TERMINATED AT STRUCTURES WING WALLS OR PIERS IN SUCH MANNER THAT ANIMALS OR CHILDREN CANNOT GAIN ACCESS TO THE FREEWAY.
- TERMINALS AT R.C. BOX U.C.: FENCE SHOULD BE TERMINATED AND BUTTING INTO THE END OF WING WALL.
- TERMINALS AT CULVERTS: FENCE SHOULD BE TERMINATED ON WING WALL WHERE THE WALL IS 2.00M HIGH. IF CULVERT HEIGHT IS LESS THAN 2.00M, THE FENCE SHOULD BE CONSTRUCTED OVER THE TOP OF THE CULVERT AS INDICATED ON DETAIL SHEET FT-1.
- WHEN WIRE MESH FENCE IS ON A WING WALL, USE METAL PIPE POST INSTEAD OF R.C. POST, SEE DETAIL B. SHEET FT-1 & DETAIL C. SHEET FT-2.
- ALL DIMENSION ARE IN CENTIMETERS UNLESS OTHERWISE NOTED.

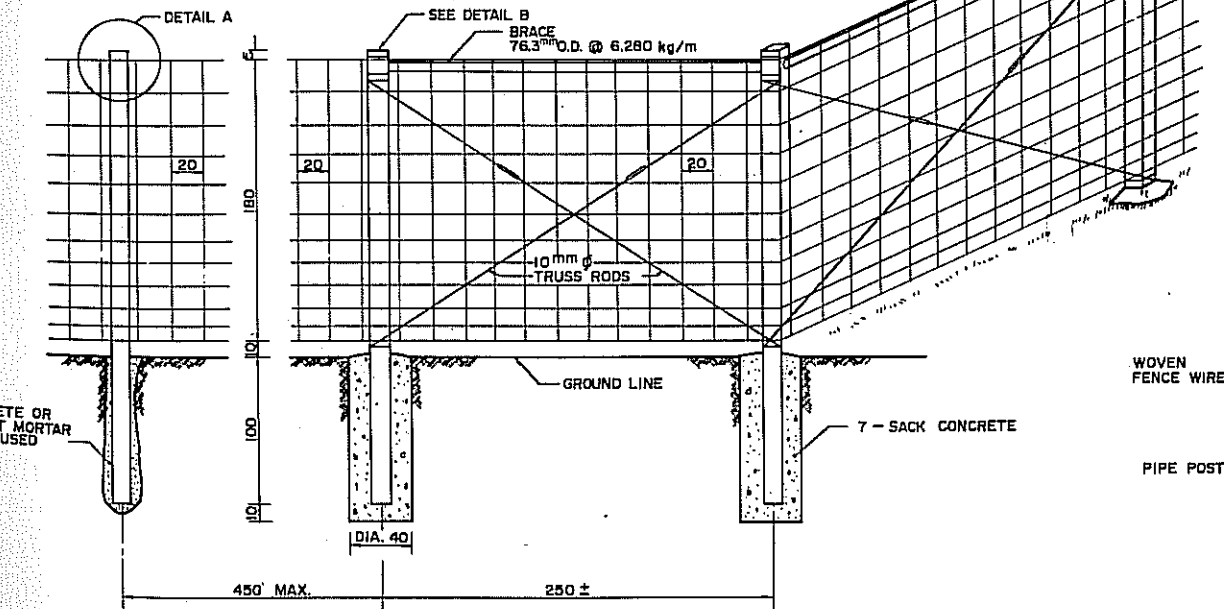

角柱或端柱裝置
CORNER OR END POST ARRANGEMENT

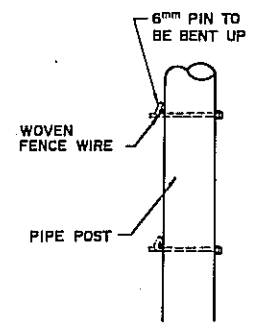

DETAIL C
METHOD OF FASTENING WIRE TO PIPE POST

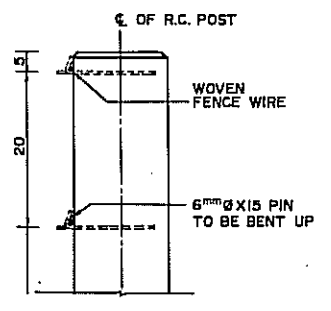

DETAIL A
METHOD OF FASTENING WIRE TO R.C. POST

FREEWAY STANDARD DETAILS		
修正	REVISIONS	交通部台灣區高速公路工程局 TAIWAN AREA FREEWAY CONSTRUCTION BUREAU 中華民國 REPUBLIC OF CHINA
項目	ITEM	南北高速公路 苗粟台中段 NORTH-SOUTH FREEWAY MIAOLI-TAICHUNG SECTION
		鐵絲網柵欄 WIRE MESH FENCE
		中華顧問工程司 CHINA ENGINEERING CONSULTANTS, INC.
		日期 DATE AUG. '74 比例 SCALE NONE 圖號 APPENDIX FT-2

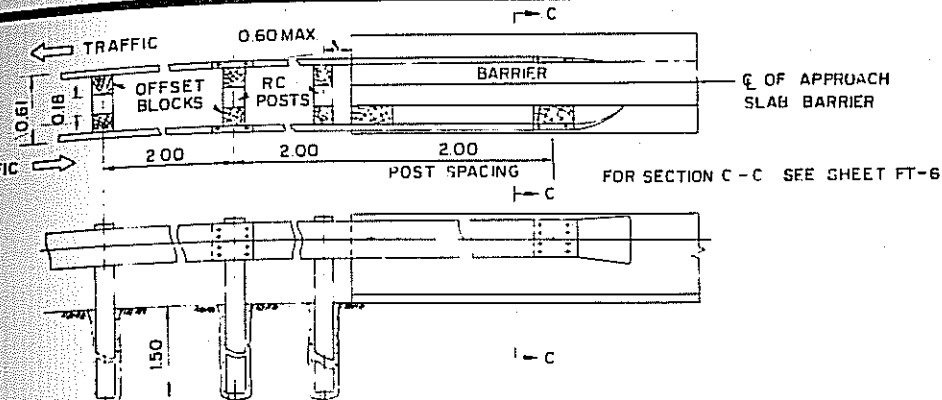

ANCHORING RAIL ELEMENT TO APPROACH SLAB BARRIER
(NOT APPLICABLE)

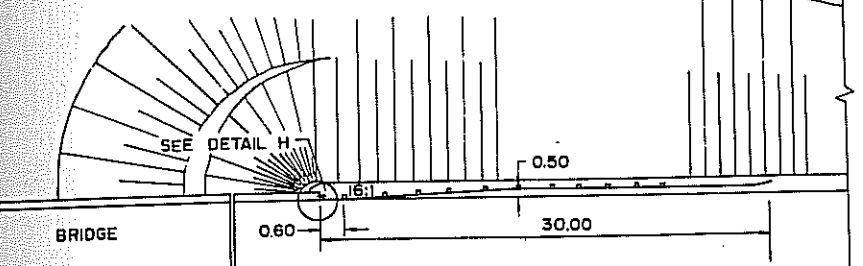

跨越橋端護欄
ANCHORING RAIL ELEMENT TO CONCRETE END BLOCK OF OVERCROSSING BRIDGE

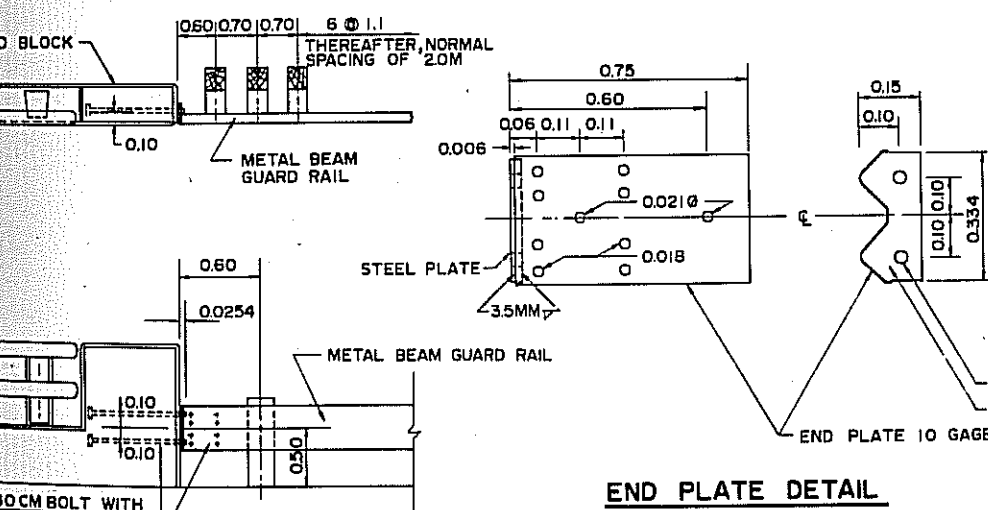

END PLATE DETAIL

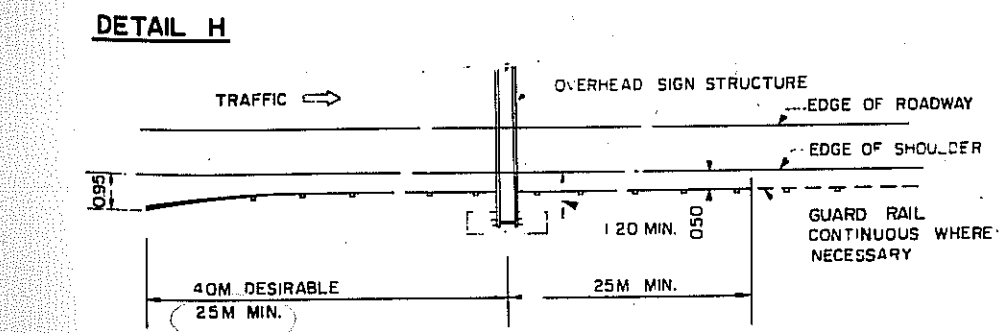

GUARD RAIL FOR OVERHEAD SIGN SUPPORT AT OUTSIDE OF SHOULDER
(NOT APPLICABLE)

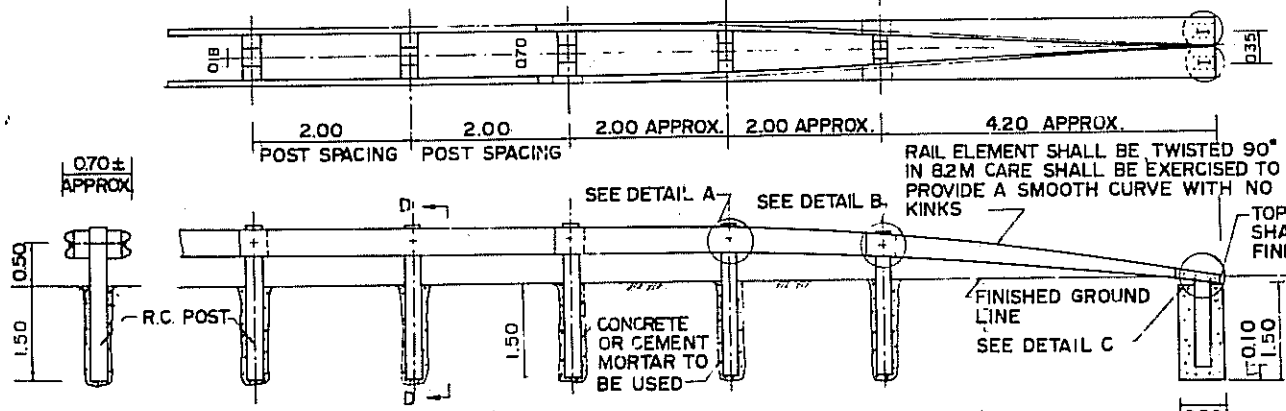

SECTION D - D
DOUBLE METAL BEAM GUARD RAILING
(NOT APPLICABLE)

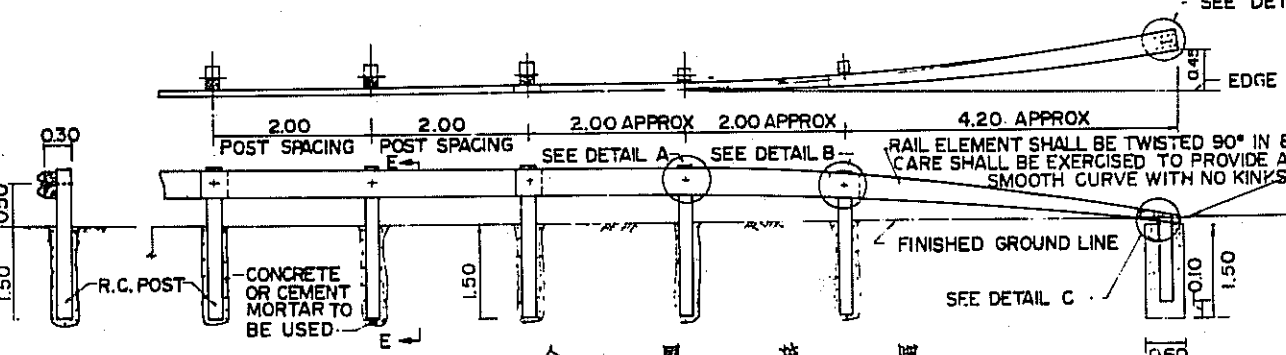

金屬護欄
METAL BEAM GUARD RAILING

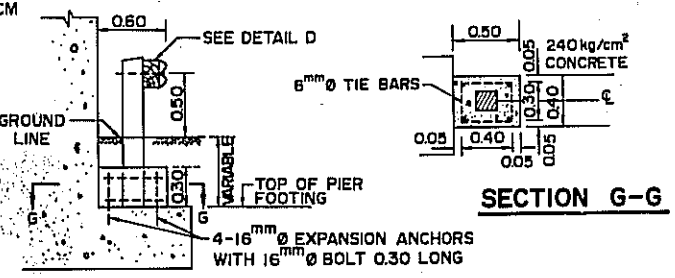

POST ANCHOR AT PIERS
(NOT APPLICABLE)

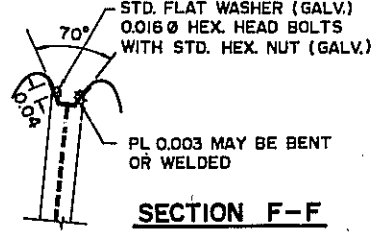

SECTION F-F

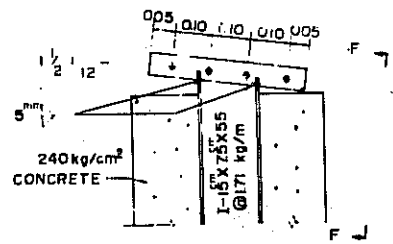

DETAIL C

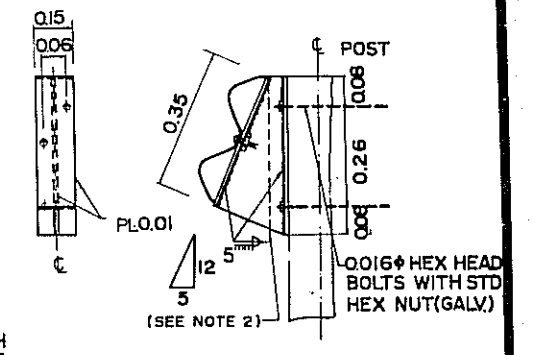

DETAIL A

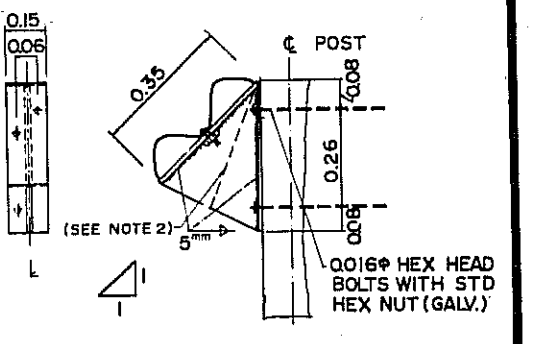

DETAIL B

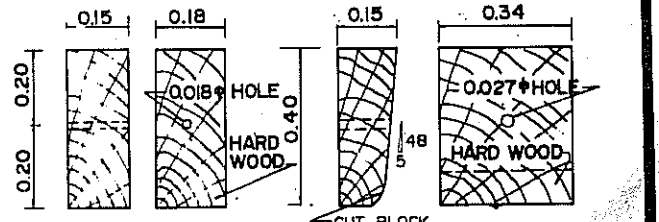

DETAIL D
(OFFSET BLOCK FOR POST)
DETAIL E
(OFFSET BLOCK FOR STRUCTURE)

說明:
1. 所有尺寸除另有註明者外, 皆以公尺計。
2. 詳圖 A, B 及 C 係使用 125mm x 75mm @ 21.83 I 型鋼沿虛線焊接。或角鐵組合, 工程師可決定是否可使用硬木墊塊代替。

NOTES:
1. ALL DIMENSION IN METERS UNLESS OTHERWISE NOTED.
2. TWO 125mm X 75mm @ 21.83 I BEAM SECTIONS MAY BE WELDED ALONG DOTTED LINES OR WOODEN BLOCKS OF NON SPLINTERING HARDWOOD MAY BE USED AS WEDGES FOR INDICATED GUARD RAIL POSITION INSTEAD OF ANGLES AND PLATES AS INDICATED IN DETAILS A, B AND C.
THE FINAL DECISION WILL BE MADE BY THE ENGINEER

修正 REVISIONS		交通部台灣區高速公路工程局	
項目 ITEM	日期 DATE	TAIWAN AREA FREEWAY CONSTRUCTION BUREAU	
		中華民國 REPUBLIC OF CHINA	
		南北高速公路 NORTH-SOUTH FREEWAY	
		苗栗台中段 MIAOLI-TAICHUNG SECTION	
		護欄 METAL BEAM GUARD RAIL (2)	
		中華顧問工程司 CHINA ENGINEERING CONSULTANTS, INC.	
		日期 DATE AUG. '74 比例 SCALE NONE 圖號 SHEET FT-4	

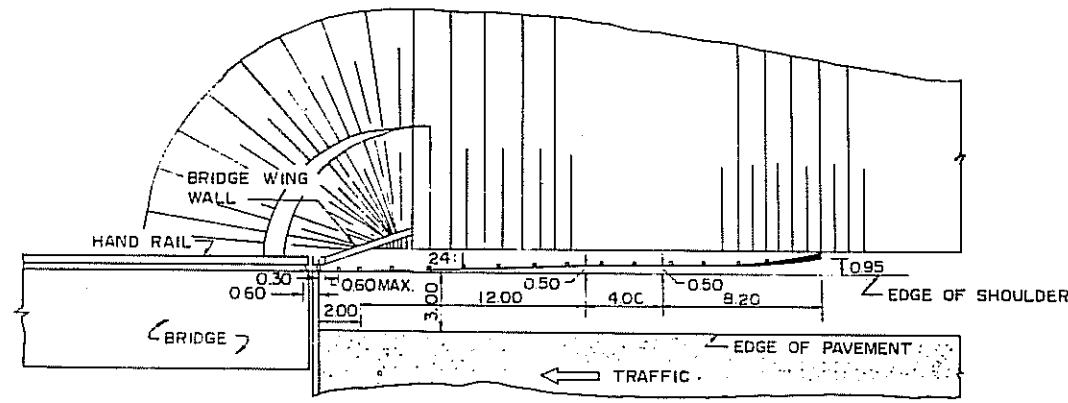
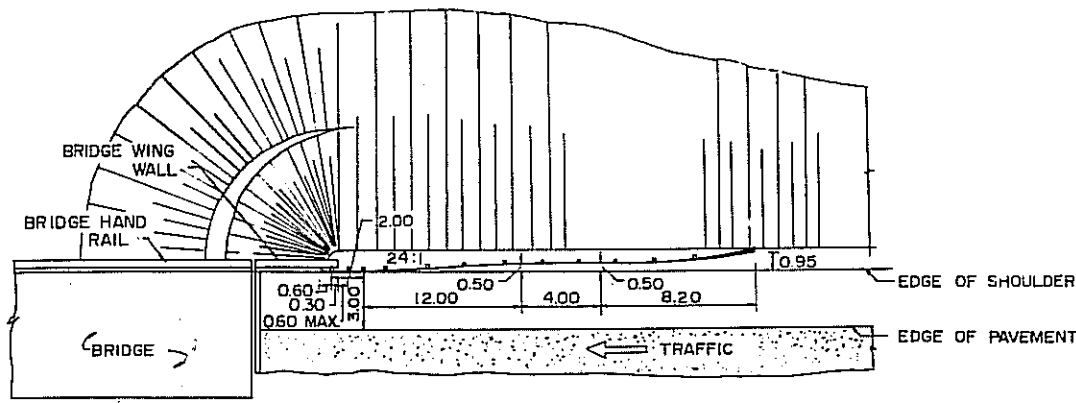

**橋端護欄設置
GUARD RAIL AT BRIDGE HAND RAIL
AND WING WALL**

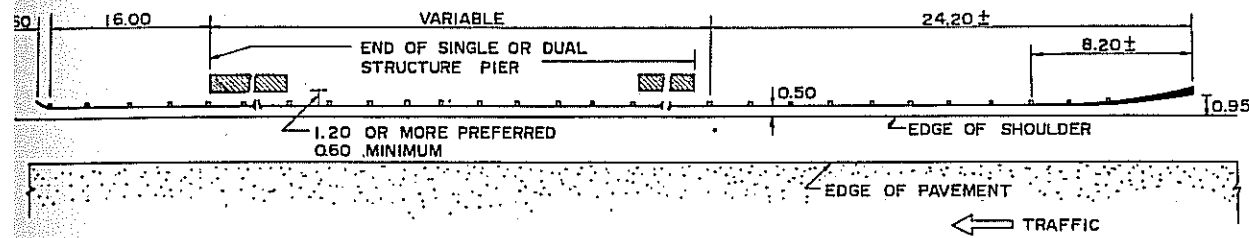

GUARD RAIL AT SHOULDER PIERS

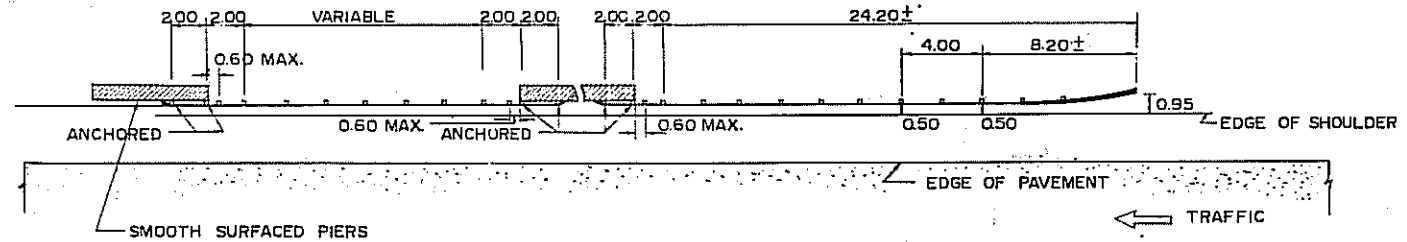

ALTERNATE SHOULDER GUARD RAIL

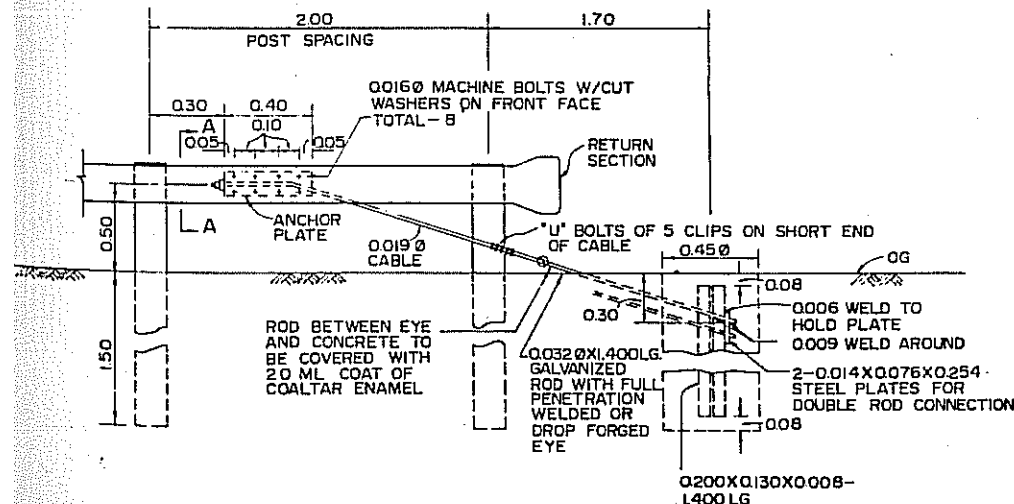
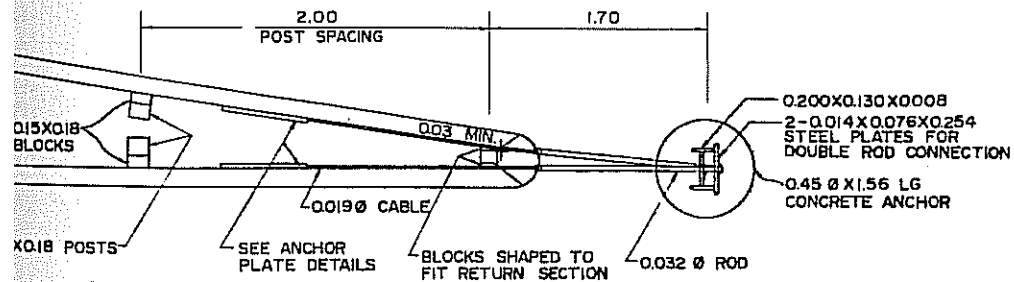

CABLE END ANCHOR FOR RETURN SECTION

(SEE NOTE 2)
(NOT APPLICABLE)

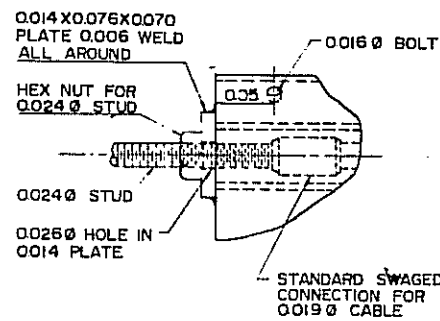

SWAGED FITTING AND STUD

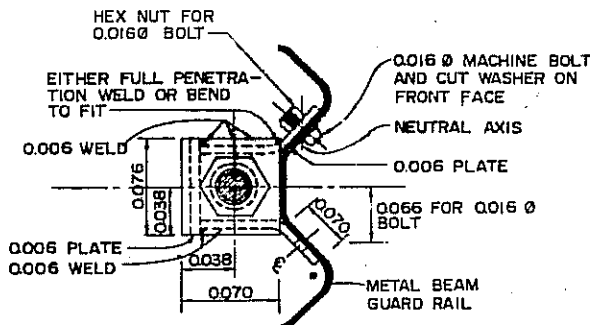

SECTION A - A

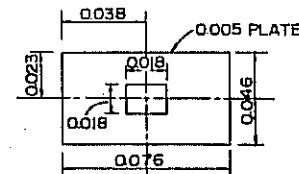

FLAT PLATE WASHER

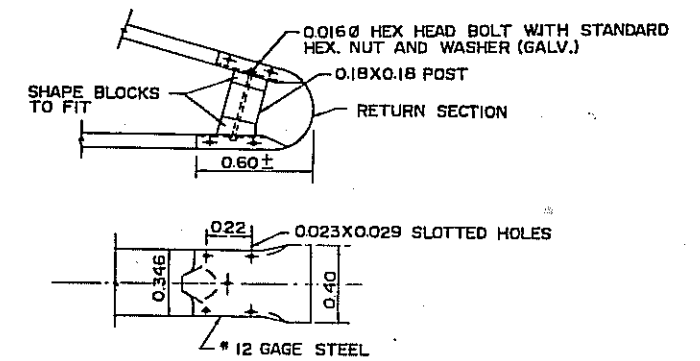

**RETURN END SECTION
(NOT APPLICABLE)**

說明:

- 所有尺寸除另有註明者外，皆以公尺計。
- 直形護欄之鐵鍊鋼索應與護欄之方向平行，曲形護欄鐵鍊鋼索之折點應在鐵鍊鋼索上。

NOTES:

- ALL DIMENSIONS ARE IN METERS UNLESS OTHERWISE NOTED.
- CABLE TO BE PARALLEL TO GUARD RAIL FOR STRAIGHT RUNS OF RAIL. CABLE MAY HAVE ANGLE POINT AT ANCHOR PLATE IF GUARD RAIL IS CURVED.

FREWAY STANDARD DETAILS

修正	REVISIONS	
項目	ITEM	日期 DATE
交通部台灣區高速公路工程局		TAIWAN AREA FREEWAY CONSTRUCTION BUREAU 中華民國 南北高速公路 NORTH-SOUTH FREEWAY 苗栗台中段 MIAOLI-TAICHUNG SECTION
護欄 METAL BEAM GUARD RAIL (3)		
中華顧問工程司 CHINA ENGINEERING CONSULTANTS, INC.		
日期 DATE	AUG. '74	比例 SCALE NONE
圖號	圖號 SHEET FT-5	

ANCHOR PLATE DETAILS

(NOT APPLICABLE)

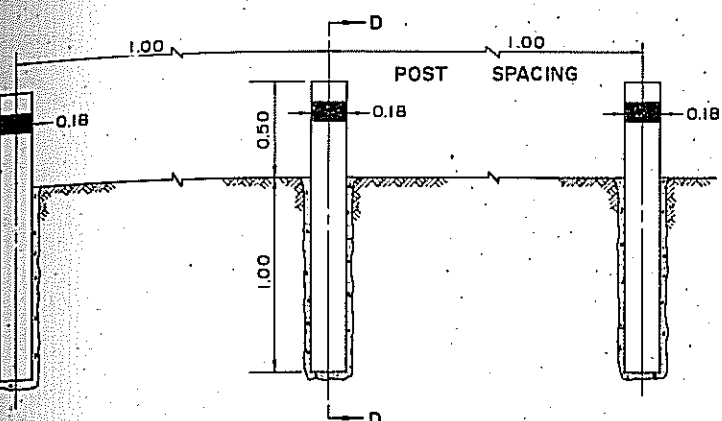

FRONT ELEVATION

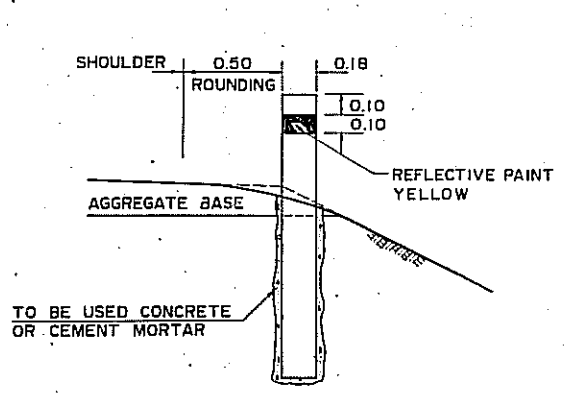

SECTION D-D

柱式護欄
R C GUIDE POST

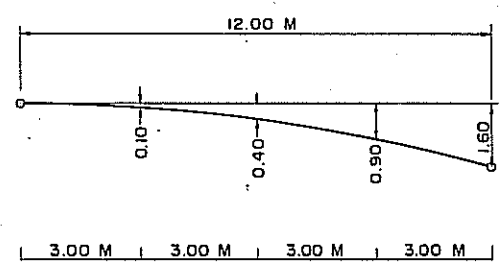

PARABOLIC LAYOUT
(NOT APPLICABLE)

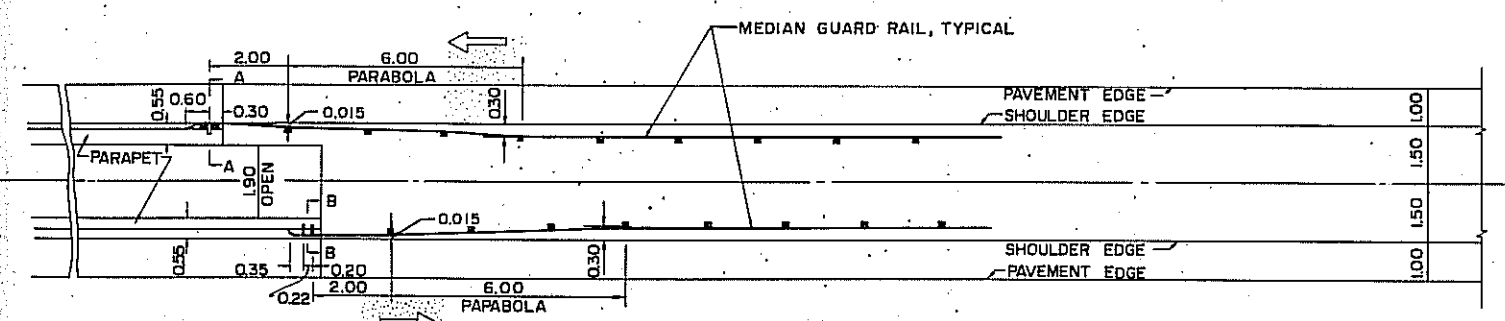

橋中央開口式分隔帶護欄設置
GUARD RAIL ADJACENT TO OPEN BRIDGE MEDIAN

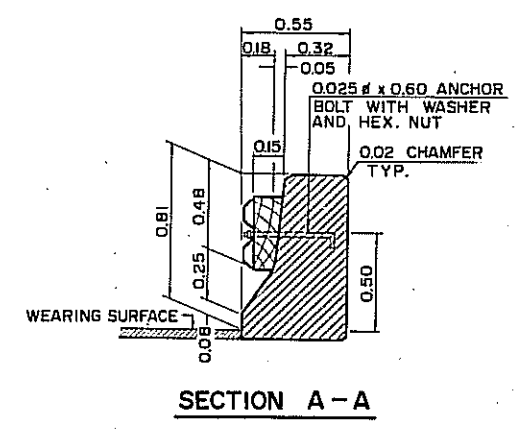

SECTION A-A

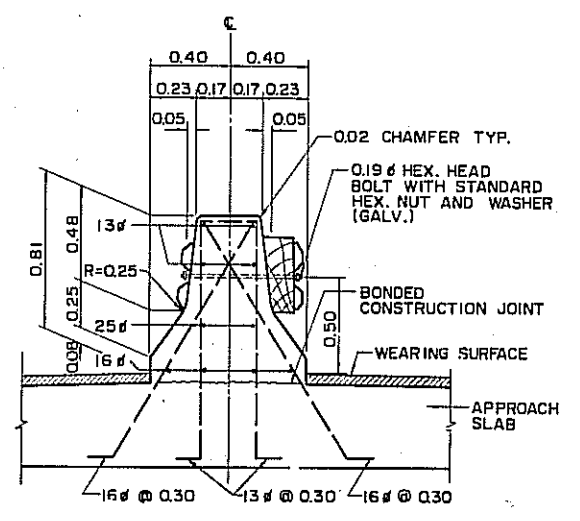

SECTION C-C
(NOT APPLICABLE)

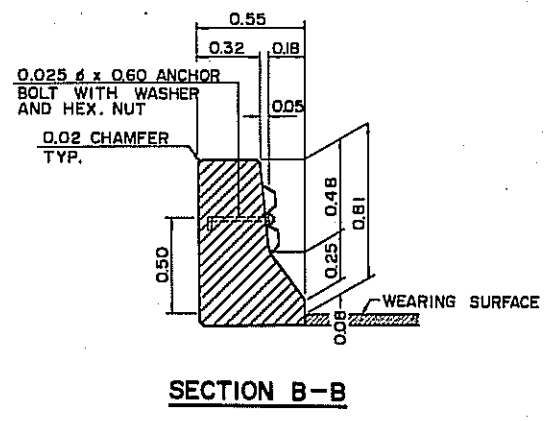

SECTION B-B

- 說明:
- 所有尺寸除另有註明外皆以公尺計。
 - 柱式護欄僅限交叉路使用。
 - 跨越橋護欄需先連接金屬護欄 30 公尺再埋設柱式護欄。
- NOTES:
- ALL DIMENSIONS ARE IN METERS UNLESS OTHERWISE NOTED.
 - R.C. GUIDE POST USED FOR CROSS RD. ONLY.
 - ANCHORING METAL BEAM GUARD RAIL TO CONCRETE END BLOCK OF OVERCROSSING BRIDGE, THE GUARD RAIL EXTENDS 30M LONG BEFORE RC GUIDE POSTS PLACEMENT.

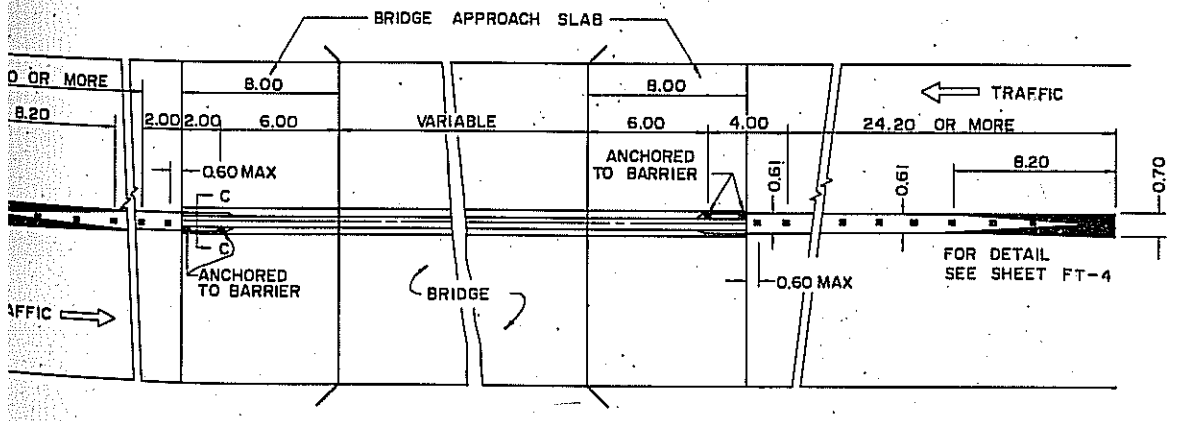

GUARD RAIL ADJACENT TO CLOSE BRIDGE MEDIAN
(NOT APPLICABLE)

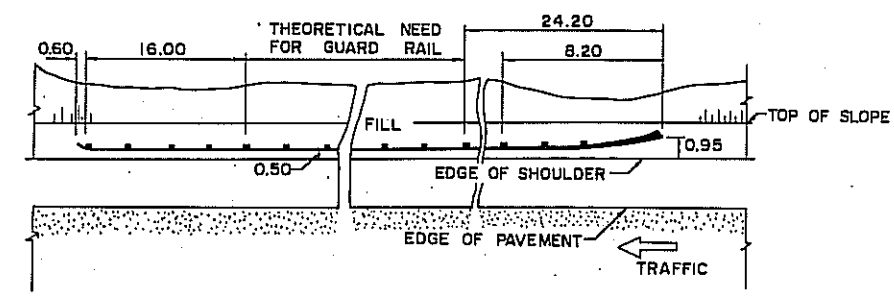

GUARD RAIL AT FILL

修正 REVISIONS		交通部台灣區高速公路工程局 TAIWAN AREA FREEWAY CONSTRUCTION BUREAU 中華民國 REPUBLIC OF CHINA	
項目 ITEM	日期 DATE	南北高速公路 NORTH-SOUTH FREEWAY 苗栗台中段 MIAOLI-TAICHUNG SECTION	
		護欄及柱式護欄 METAL BEAM GUARD RAIL AND R.C. GUIDE POST	
		中華顧問工程司 CHINA ENGINEERING CONSULTANTS, INC.	
		日期 DATE SEPT. '74	比例 SCALE NONE
		圖號 SHEET	FT-6

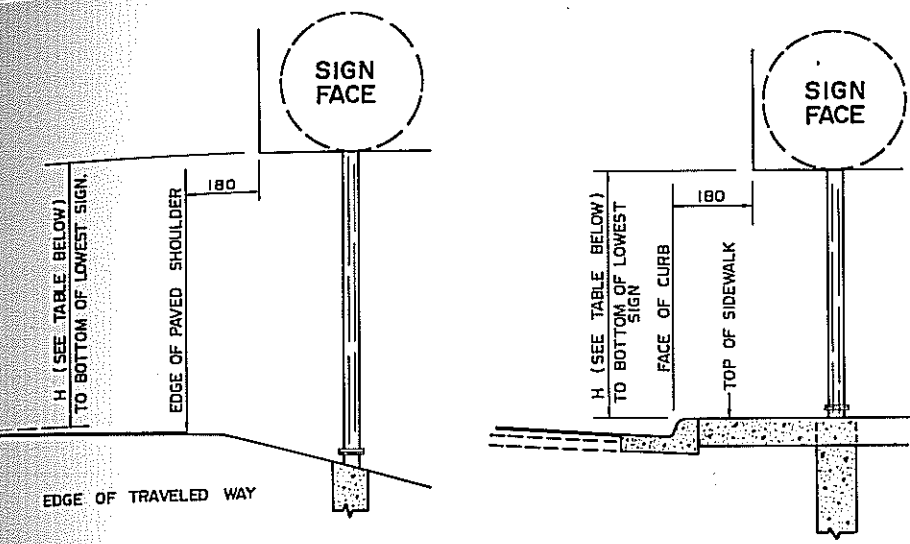

WITHOUT CURB

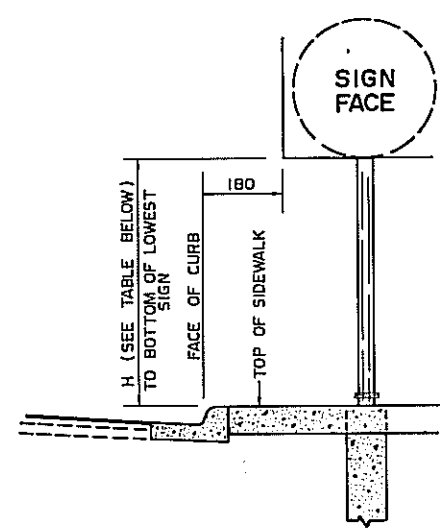

WITH CURB

標誌埋設位置
SIGN PLACEMENT

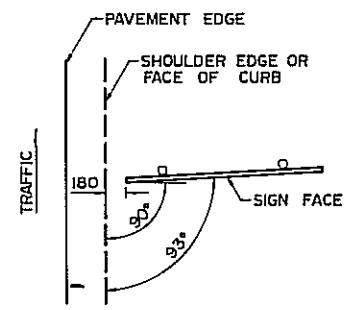

PLAN VIEW

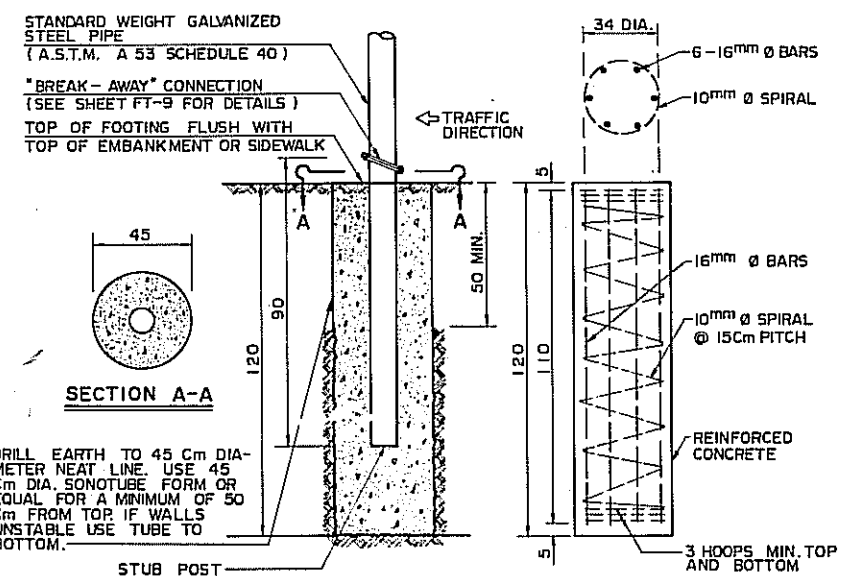

ELEVATION REINFORCING DETAIL

管柱基礎詳圖
TUBULAR POST FOOTING DETAILS

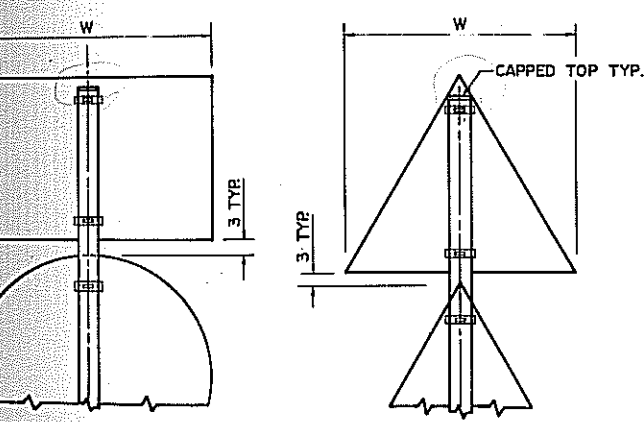

SINGLE POST

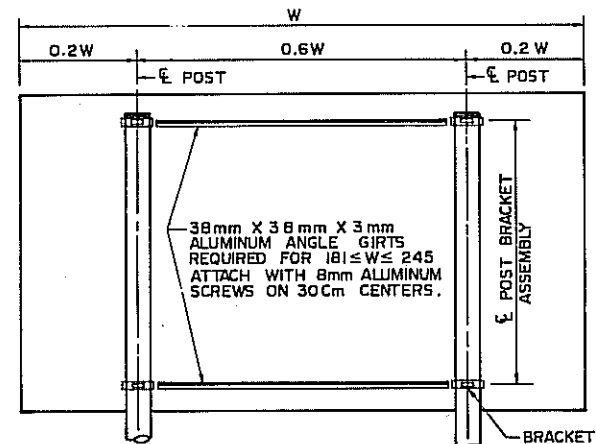

DOUBLE POST

管柱與托架間距
POST AND BRACKET SPACING

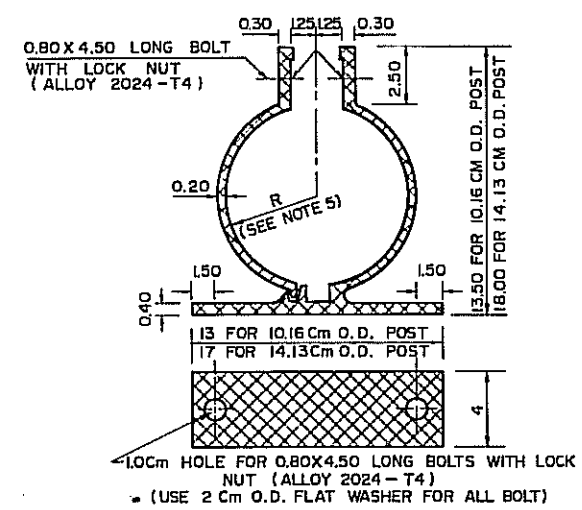

鋁製托架
ALUMINUM BRACKET ASSEMBLY DETAIL

SIGN PANEL	FREEWAY TYPE			RAMP AND LOCAL ROAD TYPE		
	NUMBER	UNIT AREA	TOTAL AREA	NUMBER	UNIT AREA	TOTAL AREA
T-1					0.254	
T-2		0.624			0.351	
T-3					0.245	
T-4					0.250	
T-5					0.351	
T-6		0.636			0.283	
T-7		0.624			0.351	
T-8					0.283	
T-9		0.636			0.283	
T-10		0.636			0.283	
T-11		0.636			0.283	
T-12		0.636			0.283	
T-13					0.283	
T-14					0.351	
T-15		0.636			0.283	
T-16					0.283	
T-17		0.360			0.360	
T-18		0.378			0.378	
T-19					0.220	
T-20					0.220	
T-21		1.036			0.683	
T-22					0.220	
T-23					0.220	
T-24					0.220	
T-25					0.220	
T-26					0.220	
T-27					0.280	
T-28		0.418			0.418	
T-29		0.418			0.418	
T-30		0.418			0.418	
T-31		0.418			0.418	
T-32		0.636				
T-33		0.636				
T-34		0.624			0.351	
T-35		0.624			0.351	
T-36		0.624			0.351	
T-37		0.624			0.351	
T-38		1.132			0.859	
T-39		0.624			0.351	
T-40		0.636				
T-41		2.660			2.660	
T-42					0.283	

PANEL ASSEMBLY	MINIMUM SIGN MOUNTING HEIGHT "H"		
	FREEWAY	RURAL	URBAN
SINGLE	180	180	210
DOUBLE	150	150	180
TRIPLE	-	120	150

SIGN PANEL THICKNESS FOR SINGLE POST MOUNTING	
W (Cm)	THICKNESS
UP TO 50	0.163
51 TO 75	0.205
76 TO 120	0.326

SIGN FACE AREA (M ²)	NUMBER OF POSTS	POST O.D.
UP TO 1.10	1	10.16
1.11 TO 2.20	2	10.16
2.21 TO 3.00	2	14.13

SIGN PANEL THICKNESS FOR DOUBLE POST MOUNTING	
W (Cm)	THICKNESS
UP TO 90	0.163
91 TO 120	0.205
121 TO 150	0.259
151 TO 180	0.326
181 TO 245	0.259

說明:

- 所有尺寸除註明者外皆以公分計。
- 標誌面大於3平方公尺使用鋁擠型材料。
- 鋁擠型面板與鋼管接觸面之處理應按照規範。
- 具有同等或較大強度鋼管代替鋁管。
- 外徑10.16公分之管柱R=5CM,外徑14.13公分之管柱R=7CM,於燈桿上之標誌使用較大支架不得有縫隙。
- "脫離接口"詳閱圖FT-9。

NOTES:

- ALL DIMENSIONS ARE IN CENTIMETERS EXCEPT WHERE NOTED OTHERWISE.
- USE EXTRUDED ALUMINUM PANELS FOR SIGN FACE AREAS GREATER THAN 3 M².
- SEE SPECIFICATIONS FOR TREATMENT OF CONTACT SURFACES BETWEEN THE ALUMINUM SIGN PANEL AND THE STEEL POST.
- A STEEL BRACKET ASSEMBLY OF EQUAL OR GREATER STRENGTH MAY BE SUBSTITUTED FOR THE ALUMINUM BRACKET ASSEMBLY.
- R=5CM FOR 10.16 CM O.D. POST AND R=7CM FOR 14.13 CM O.D. POST. USE LARGER BRACKET FOR SIGNS TO BE MOUNTED ON LIGHT POLES SHIMS NOT PERMITTED.
- SEE SHEET FT-9 FOR "BREAK-AWAY" DETAILS.

SUMMARY OF QUANTITIES (參閱各標工程數量計算書)

SIGN INSTALLATIONS:			
SINGLE POST	EACH		
DOUBLE POST	EACH		
TUBULAR POSTS			
10.16 Cm O. D.	EACH	L.M.	
14.13 Cm O. D.	EACH	L.M.	
CONCRETE FOOTINGS	EACH		
SIGN PANEL AREA		M ²	

FREEWAY STANDARD DETAILS

修正 REVISIONS	項目 ITEM	日期 DATE	交通部台灣區高速公路工程局 TAIWAN AREA FREEWAY CONSTRUCTION BUREAU 中華民國 REPUBLIC OF CHINA
			南北高速公路 NORTH-SOUTH FREEWAY 苗栗台中段 MIAOLI-TAICHUNG SECTION
			鋁板標誌 SIGN DETAILS SHEET ALUMINUM PANELS
			中華顧問工程司 CHINA ENGINEERING CONSULTANTS, INC. 日期 DATE AUG. '74 比例 SCALE NONE 圖號 APPENDIX FT-7

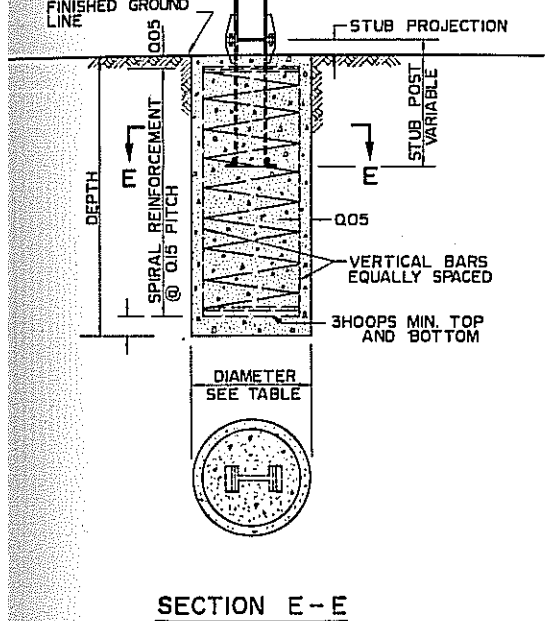
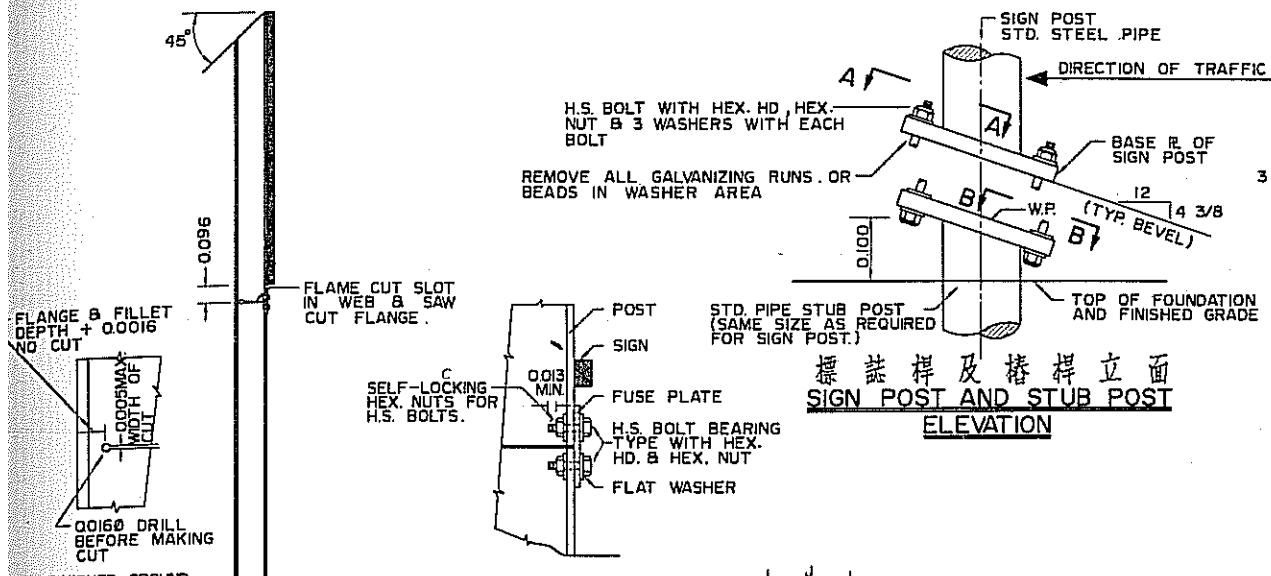

TUBULAR POST TABLE

BASE CONNECTION DATA TABLE

PIPE SIZE O.D. CM	BOLT SIZE TORQUE	A	B	C	D	E	F	T ₁	W
10.16	0.0130 x 0.065 23 kg-m	0.15	0.20	0.025	0.10	0.02	0.16	0.02	0.009
14.13	0.0160 x 0.07 52 kg-m	0.18	0.25	0.032	0.116	0.022	0.206	0.025	0.011

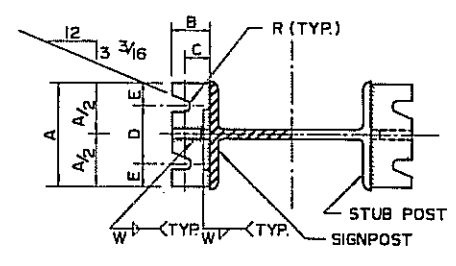
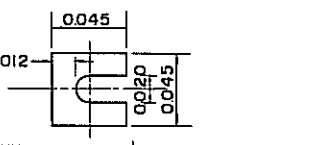
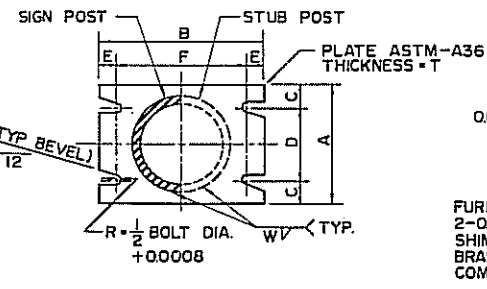
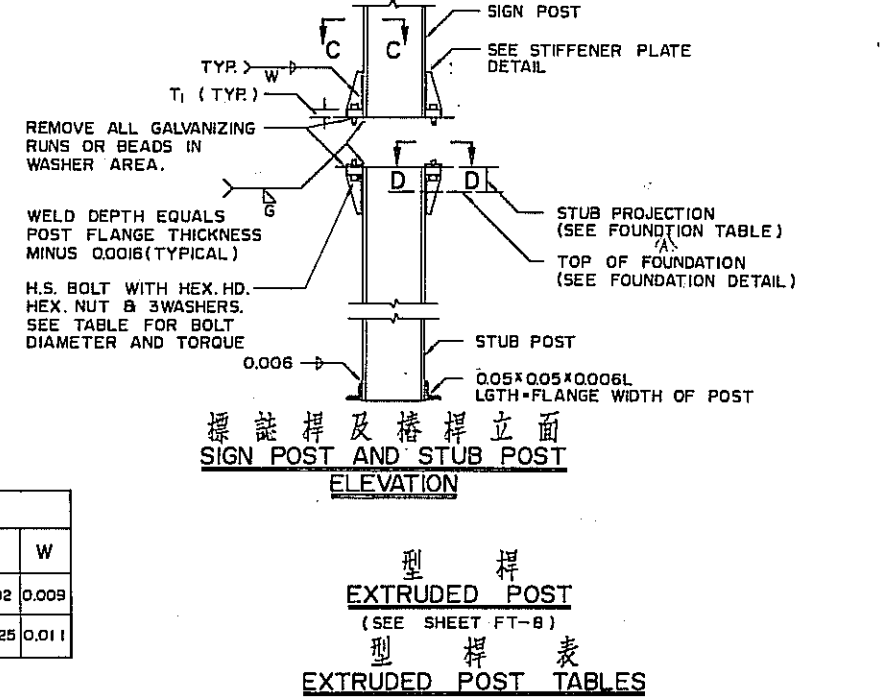
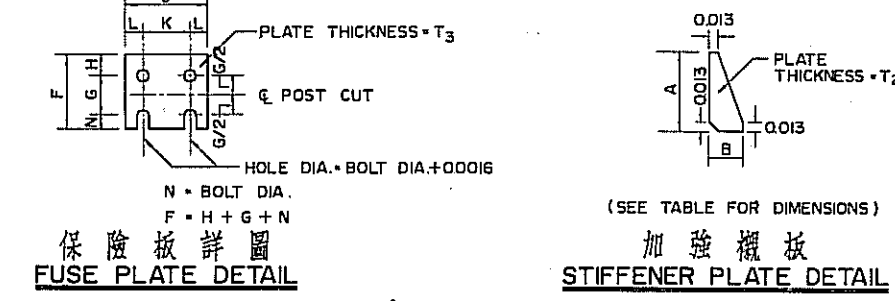

SOIL CONDITIONS: $\gamma = 120 \text{ lb/ft}^3$, $\phi = 30^\circ$, $C = 750 \text{ lb/ft}^2$ OR $\gamma = 120 \text{ lb/ft}^3$, $\phi = 36^\circ$, $C = 500 \text{ lb/ft}^2$ OR $\gamma = 120 \text{ lb/ft}^3$, $\phi = 0^\circ$, $C = 1600 \text{ lb/ft}^2$

說明
設計：標誌牌構造物之設計及施工須依照工程規範。
荷重：風速每小時 180 公里
單位應力：結構鋼材及鋁材按 AASHTO 規範之規定。
鋼筋 $f_s = 1400$ 公斤/平方公分 混凝土 $f_c = 240$ 公斤/平方公分 28 天
焊接：1. 另有註明者外所有焊接皆為全焊。 2. 焊接工作須依照 AWS 現行規範。
3. 焊接 ASTM A-36 鋼材及型鋼或 A-53 結構鋼管須使用 E6010, 11 或 27 或 ASTM A-233 64T 電焊條。 4. 焊接 ASTM A-441 鋼材及型鋼須使用 E-70XX 低氫電焊條 CE 7015, E7018 7028。
材料：結構鋼管須符合 ASTM A-53 規範有關之規定。
與結構鋼管併用使用之結構鋼材須符合 ASTM A-36 規範。
所有寬緣工字梁及併用使用之結構鋼材須符合 ASTM A-441 規範。
高強度螺栓及墊圈須符合 ASTM A-325 規範，使用之高強度螺絲須足以承受高強度螺絲應有之應力。
高強度螺絲螺帽墊圈須依照 ASTM A-153 規範鍍鋅處理，鍍鋅後墊圈硬度為 33-34 時准予使用。
高強度螺栓及基板接合規定之扭力矩如附表。
柱桿，基板及樁桿須於製造完成後按 ASTM A-123 及 A-385 規範鍍鋅處理，鍍鋅後再不得於裝配時打洞鑽孔及切割。
裝配程序：柱桿，樁桿，基板，高強度螺栓及板間平版墊圈聯結如圖所示。
必要時，得加填隙片調整。
依規定次序將強力螺栓按規定之扭力矩旋緊，旋緊後再按原先之順序及規定之扭力矩放鬆扭固。
除另有註明外，所有尺寸均以公尺計。

NOTES:

DESIGN: LOCAL SPECIFICATIONS FOR THE DESIGN AND CONSTRUCTION OF STRUCTURAL SUPPORTS FOR HIGHWAY SIGNS.

LOADING: FOR WIND SPEED OF 180 KM PER HOUR.

UNIT STRESSES: STRUCTURAL STEEL AND ALUMINUM: - PER AASHTO.

REINFORCING STEEL: $f_s = 1400 \text{ KG/CM}^2$

CONCRETE $f_c = 240 \text{ KG/CM}^2 @ 28 \text{ DAYS}$.

WELDING: ALL WELDING TO BE CONTINUOUS UNLESS OTHERWISE SHOWN.

ALL WELDING TO BE DONE ACCORDING TO CURRENT AWS SPECIFICATIONS.

WELDING ON ASTM A-36 PLATES OR SHAPES OR ASTM A-53 STRUCTURAL TUBING SHALL BE DONE WITH ELECTRODES E6010, 11 OR 27 ASTM A-233 64T.

WELDING ON ASTM A-441 PLATES AND SHAPES SHALL BE DONE WITH E-70XX LOW-HYDROGEN ELECTRODES (E 7015, E 7018 OR 7028).

MATERIALS: HOLLOW STRUCTURAL STEEL TUBING SHALL CONFORM TO THE REQUIREMENTS OF ASTM DESIGNATION A-53 "HOT FORMED WELDED AND SEAMLESS CARBON STEEL STRUCTURAL TUBING".

ALL OTHER STRUCTURAL STEEL SHAPES AND PLATES USED WITH HOLLOW STRUCTURAL STEEL TUBING SHALL CONFORM WITH ASTM DESIGNATION A-36.

ALL WF BEAMS, STRUCTURAL STEEL SHAPES AND PLATES USED WITH THE WF BEAMS SHALL CONFORM WITH ASTM A-441.

ALL HIGH STRENGTH BOLTS AND WASHERS SHALL CONFORM WITH ASTM A-325 ALL HIGH STRENGTH NUTS SHALL BE OF SUCH CAPACITY TO DEVELOP THE BOLT STRENGTH.

HIGH STRENGTH STEEL BOLTS, NUTS AND HARDENED WASHERS SHALL BE GALVANIZED IN ACCORDANCE WITH ASTM A-153 EXCEPT WASHER HARDNESS OF 33-34 AFTER GALVANIZING WILL BE ACCEPTABLE.

HIGH STRENGTH BOLTS IN BASE PLATES SHALL BE TIGHTENED TO THE TORQUE SHOWN IN THE TABLE.

THE POSTS, BASE PLATES AND STUB POSTS SHALL BE GALVANIZED IN ACCORDANCE WITH ASTM DESIGNATION A-123 AND A-385 AFTER FABRICATION. ALL FABRICATION SHALL BE COMPLETED AND READY FOR ASSEMBLY BEFORE GALVANIZING. NO PUNCHING, DRILLING OR CUTTING SHALL BE PERMITTED AFTER GALVANIZING.

PROCEDURE FOR ASSEMBLY OF BASE CONNECTION: ASSEMBLE POST TO STUB WITH H.S. BOLTS AND ONE FLAT WASHER ON EACH BOLT BETWEEN PLATES AS SHOWN.

SHIMS MAY BE USED BETWEEN PLATES TO LEVEL POST.

TIGHTEN BOLTS IN BASE PLATE IN A SYSTEMATIC ORDER TO THE REQUIRED TORQUE.

LOOSEN EACH BOLT AND RETIGHTEN TO THE REQUIRED TORQUE IN SAME ORDER AS INITIAL TIGHTENING.

ALL DIMENSIONS IN METERS UNLESS OTHERWISE NOTED.

FREWAY STANDARD DETAILS

修正 項目	REVISIONS DATE	交通部 TAIWAN AREA 中華 REPUBLIC OF CHINA
交通部 TAIWAN AREA 中華 REPUBLIC OF CHINA	交通部 TAIWAN AREA 中華 REPUBLIC OF CHINA	交通部 TAIWAN AREA 中華 REPUBLIC OF CHINA
南北高速公路 NORTH-SOUTH FREWAY 苗栗台中段 MIAOLI-TAICHUNG SECTION		標誌 SIGN POST
中華顧問工程司 CHINA ENGINEERING CONSULTANTS, INC.		中華顧問工程司 CHINA ENGINEERING CONSULTANTS, INC.
日期 DATE	AUG. '74 比例 SCALE	NONE 圖號 APPENDIX FT-9

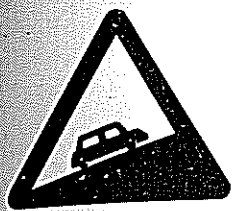

STEEP ASCENT
T-34



STEEP DESCENT
T-35

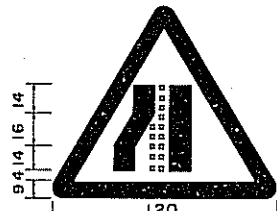

LEFT LANE DROP
T-36



RIGHT LANE DROP
T-37

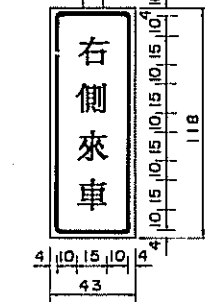

MERGING TRAFFIC
T-38

STATION	w	a	b	c	d	e	XX

a 35, 40, 35, 40, 35, 40, 35, b c d 35, 40, 35, e

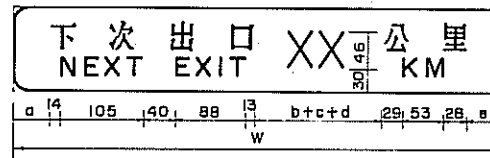

E-4
W/G



TWO-WAY TRAFFIC
T-39



MINIMUM SPEED
T-40
W/BL

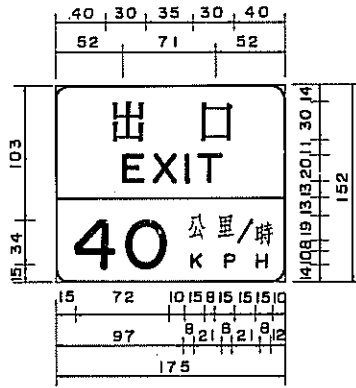

T-41
B/Y

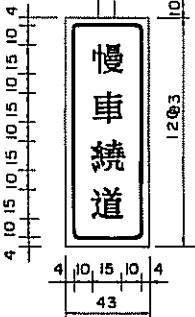

T-42
W/BL

LEGEND

B = BLACK G = GREEN BL = BLUE W = WHITE
Y = YELLOW BR = BROWN R = RED O = ORANGE
B/W = BLACK LEGEND ON WHITE BACKGROUND.
T = SIGN TO BE MOUNTED ON TUBULAR POST (SEE SHEET FT-8).
E = SIGN TO BE ON EXTRUDED ALUMINUM PANELS MOUNTED ON WF BEAM POSTS (SEE SHEET FT-9).

NOTES

- ALL DIMENSIONS ARE IN CENTIMETERS UNLESS OTHERWISE NOTED.
- INTERNATIONAL SIGN DIMENSIONS :
(A) FREEWAY SIGNS (B) RAMP AND CROSSROAD SIGNS
TRIANGULAR SIGNS = 120 CM TRIANGULAR SIDE = 90 CM
CIRCULAR Ø. D. = 90 CM CIRCULAR Ø. D. = 60 CM
BORDER = 9 CM BORDER = 7 CM
- SIGN BORDER :
(A) BORDERS TO BE SAME COLOR AS LEGEND UNLESS OTHERWISE NOTED.
(B) BORDER WIDTH SHALL BE 5 CENTIMETERS FOR GUIDE SIGNS HAVING THE LARGEST CHARACTER HEIGHT GREATER THAN 38 CENTIMETERS. THE CORNER ROUNDING SHALL HAVE A RADIUS EQUAL TO ONE-EIGHTH OF THE LESSER SIDE DIMENSION BUT SHOULD NOT EXCEED 30 CENTIMETERS.
(C) OTHER GUIDE SIGNS SHALL HAVE THE BORDER SHOWN BELOW FOR THE APPROPRIATE BACKGROUND :

圖例
B-黑色 G-綠色 BL-藍色 W-白色
Y-黃色 BR-棕色 R-紅色 O-橙色
B/W-白底黑色圖案
T-管柱標誌
E-嵌板標誌

說明

- 所有尺寸除註明者外，均以公分計。
- 國際標準標誌牌尺寸：
A. 高速公路
三角型標誌每邊長 = 120 CM
圓型標誌直徑 = 90 CM
邊寬 = 9 CM
B. 匝道及交叉道路
三角型標誌每邊長 = 90 CM
圓型標誌直徑 = 60 CM
邊寬 = 7 CM
3. 標誌牌之邊帶
X A. 邊帶顏色除另有註明者外，均按照圖例規定辦理。
X B. 指示標誌最大字體高度大於 35 公分時，標誌邊帶寬為 5 公分，圓角半徑為標誌牌最短邊之八分之一，但不得超過 30 公分。
✓ C. 其他指示標誌邊帶底色，配合如下圖所示

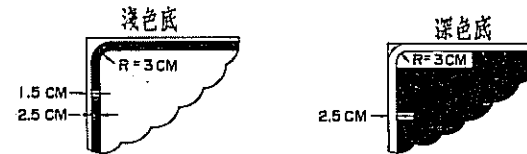

- 標誌牌顏色，應按台灣省公路局頒佈之標誌有關規定辦理，除另有註明者外，所有指示標誌，為綠底白色圖案。
- 字之大小及間距參照施工技術規範。
- 標誌牌之底色及圖案除黑色外均須具有反光性質。
- T-2 標誌需正確顯示道路交叉形狀，T-36 及 T-37 須正確顯示減少車道數。

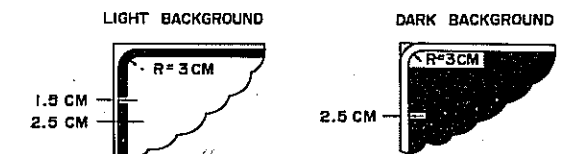

- COLORS ON STANDARD INTERNATIONAL SIGNS SHALL FOLLOW THE TAIWAN HIGHWAY BUREAU SIGNING MANUAL. ALL GUIDE SIGNS SHALL HAVE A WHITE LEGEND ON GREEN BACKGROUND UNLESS OTHERWISE NOTED.
- SEE TECHNICAL PROVISIONS FOR THE LETTERING SIZE AND SPACING.
- ALL SIGNS SHALL HAVE REFLECTORIZED BACKGROUNDS. ALL LEGENDS SHALL BE REFLECTORIZED EXCEPT THOSE SYMBOLS WHICH ARE BLACK IN COLOR.
- THE SYMBOL ON THE JUNCTION AHEAD SIGN (T-2) SHALL EXHIBIT THE GEOMETRIC SHAPE OF THE INTERSECTION. LANE DROP SIGNS (T-36 AND T-37) SHALL SHOWS THE CORRECT NUMBER OF LANES.

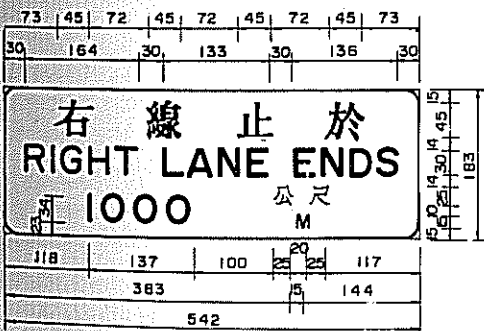

E-1
W/G

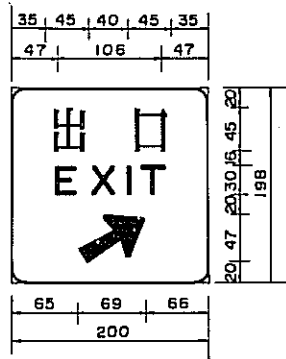

E-2
W/G

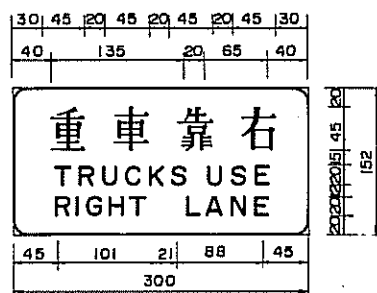

E-3
B/W

STANDARD ARROW DIMENSIONS

FREEWAY ARROWS

NON-FREEWAY ARROWS

TYPE A: VERTICAL OR DIAGONAL

TYPE B: VERTICAL DOWN

TYPE C: EXIT (E-2)

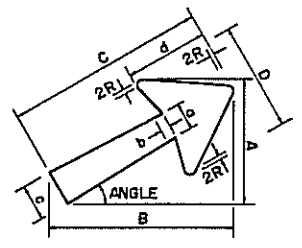
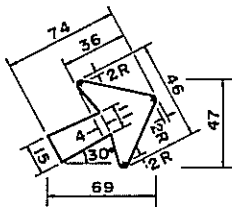
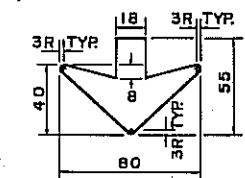
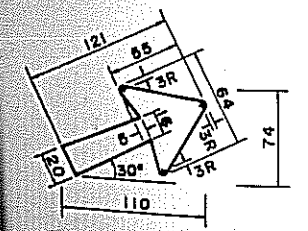

a = 0.152 C c = 0.200 C
b = 0.050 C d = 0.480 C
(ROUND TO THE NEAREST CENTIMETER)

ANGLE	LETTER SIZE (CM)	ARROW DIMENSIONS (CM)			
		A	B	C	D
30°	10-15 CAPS	32	47	51	29
	20 CAPS	42	61	66	38
	25 CAPS-27 U G	53	79	86	46
	30 CAPS-34 U C	63	97	107	46
45°	38 CAPS-41 U C	74	110	121	57
	10-15 CAPS	40	40	51	29
	20 CAPS	51	51	66	38
	25 CAPS-27 U C	67	67	86	46
60°	30 CAPS-34 U C	81	81	107	46
	38 CAPS-41 U C	93	93	121	57
	10-15 CAPS	47	32	51	29
	20 CAPS	61	42	66	38
60°	25 CAPS-27 U C	79	53	86	46
	30 CAPS-34 U C	97	64	107	46
	38 CAPS-41 U C	110	74	124	57

FREEWAY STANDARD DETAILS

修正 REVISIONS	交通部台灣區高速公路工程局
項目 ITEM	TAIWAN AREA FREEWAY CONSTRUCTION BUREAU
日期 DATE	中華民國
	南北高速公路 NORTH-SOUTH FREEWAY
	苗栗台中段 MIAOLI-TAICHUNG SECTION
	標誌牌面 SIGN FACE STANDARDS (II)
	中華顧問工程司 CHINA ENGINEERING CONSULTANTS, INC.
日期 DATE	AUG. '74 比例 SCALE NONE 圖號 APPENDIX FT-11

exit ramp

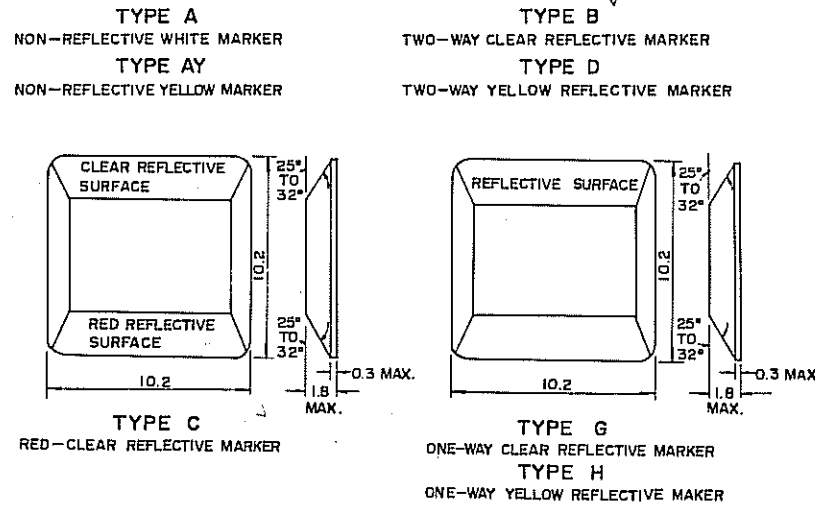
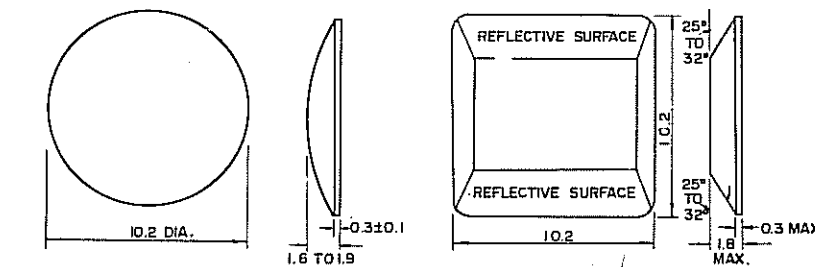
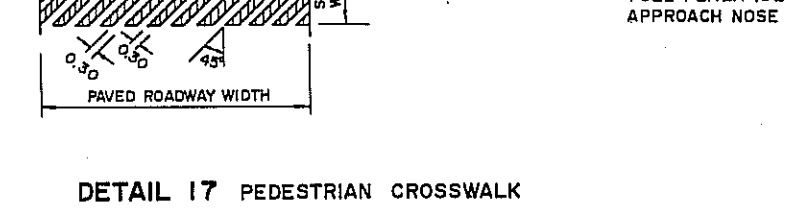
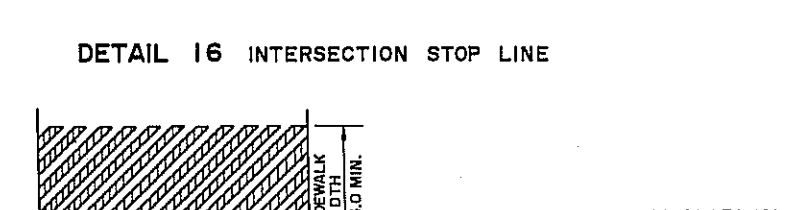
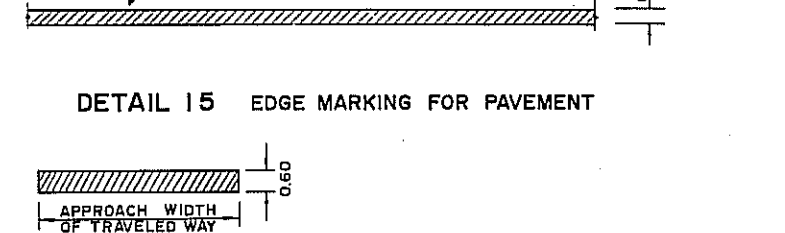
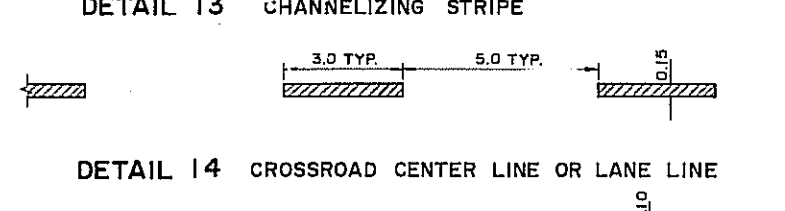
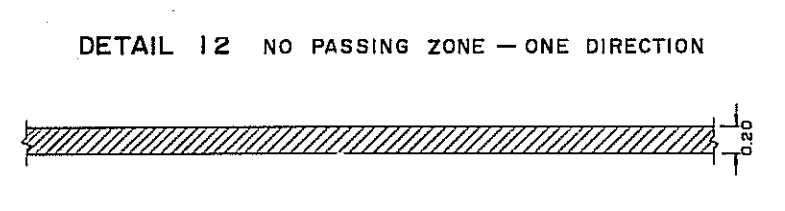
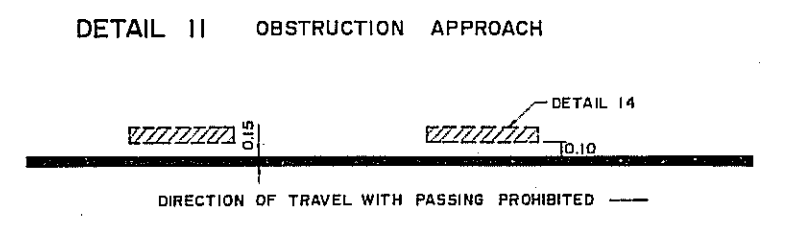
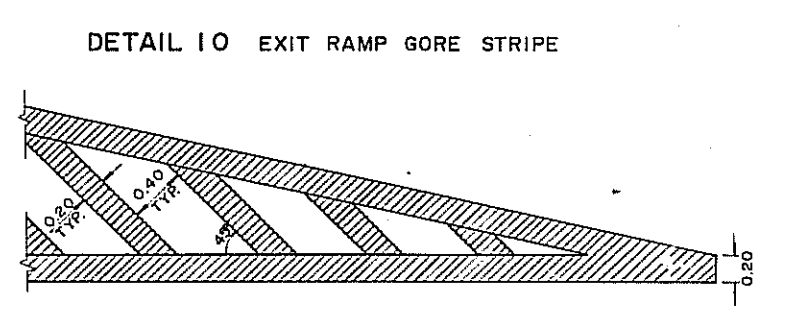
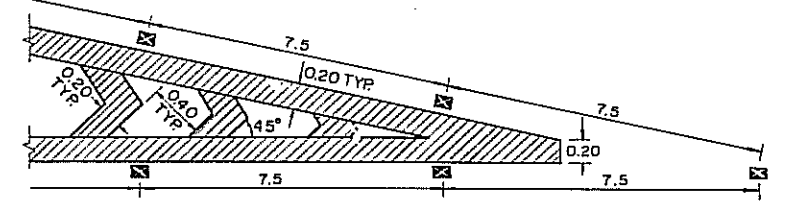
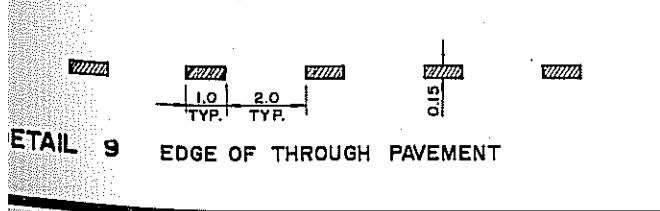
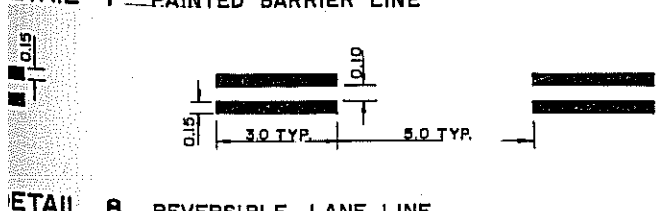
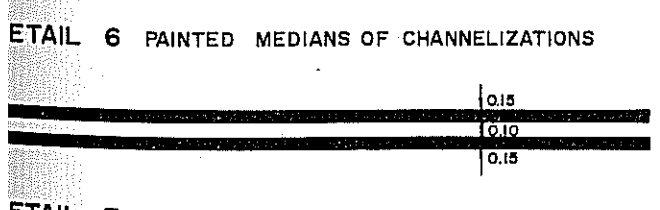
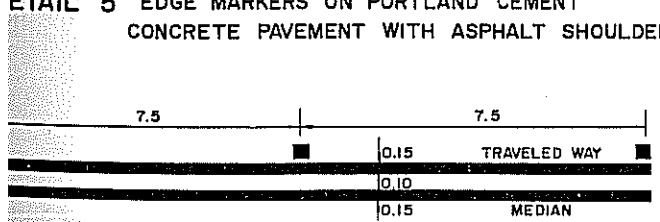
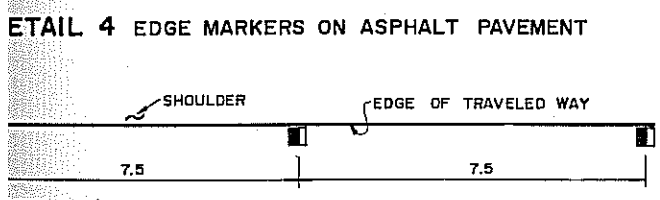
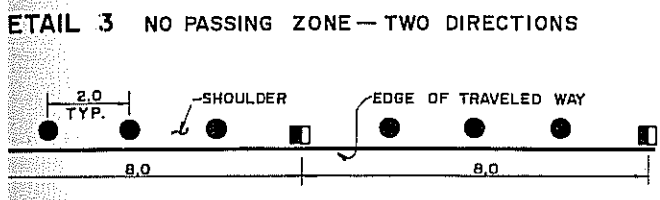
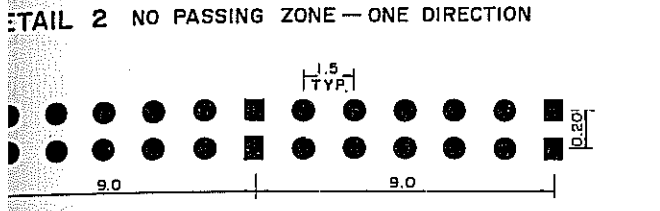
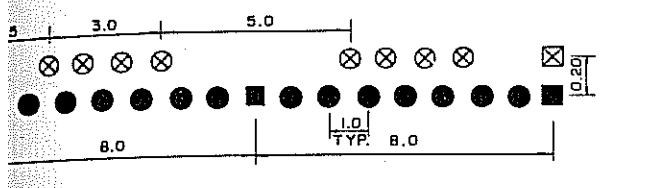
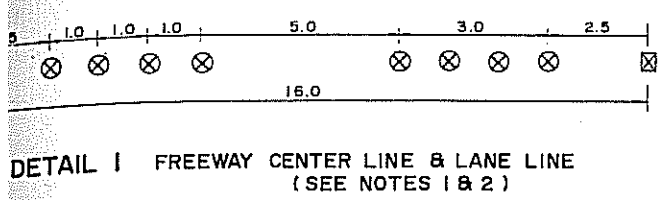

LEGEND

STRIPE		REFLECTIVE	
	WHITE PAINT		TYPE B OR C
	YELLOW PAINT		TYPE D - 2-WAY YELLOW
	THERMOPLASTIC		TYPE G - 1-WAY CLEAR
MARKER			TYPE H - 1-WAY YELLOW
NON-REFLECTIVE			
	TYPE A - WHITE		
	TYPE AY - YELLOW		

PAVEMENT MARKER DETAILS
(DIMENSIONS IN CENTIMETERS)

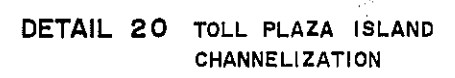
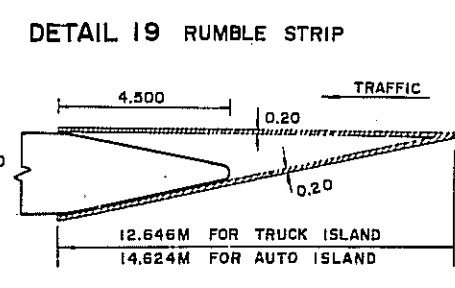
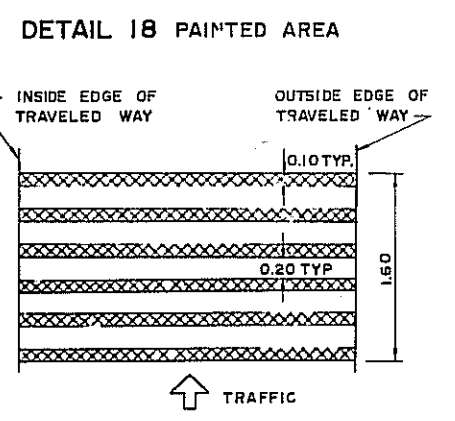
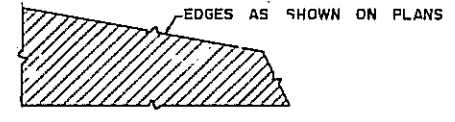

說明

- 除另有註明者外，直線及曲線半徑大於300公尺時，反光標誌設置間隔16公尺，半徑小於300公尺，設置間隔8公尺。
- 高速公路使用C型，雙線主要公路使用B型，多線之不分隔公路使用G型標誌。
- G型及H型標誌反光面朝向來車，C型白反光面朝向來車。
- 公路上已有標誌時，標誌間距應適當調整，使不反光標誌在標誌之上。
- 向下抹角約45°之陶磁標誌，雖與詳圖不盡相同，亦准使用。
- 除另有註明外，標誌尺寸容許誤差為0.003公尺。
- 交叉路間標誌距中心線交點應相同，每邊至少應設B組8公尺間距標誌。
- 標誌與鄰接標誌之淨距為0.04公尺。
- 全部尺寸，除註明者外，皆以公尺計。
- 減速標誌（詳圖19）用厚6MM無反光，白色熱塑性可塑物，設置方向與行車方向垂直。

NOTES:

- PLACE REFLECTIVE MARKERS AT 16M INTERVALS ON TANGENTS AND ON CURVES OF 300M RADIUS OR GREATER, AND AT 8M INTERVALS ON CURVES WITH LESS THAN 300M RADIUS, UNLESS OTHERWISE SHOWN.
- USE TYPE C MARKERS ON FREEWAYS. USE TYPE B MARKERS ON TWO LANE ARTERIAL HIGHWAYS AND USE TYPE G MARKERS ON MULTILANE UNDIVIDED HIGHWAYS.
- TYPE G AND TYPE H MARKERS WILL BE PLACED WITH REFLECTIVE SURFACE FACING ONCOMING TRAFFIC. TYPE C MARKERS WILL BE PLACED WITH THE CLEAR REFLECTIVE SURFACE FACING ONCOMING TRAFFIC.
- WHEN MARKERS ARE PLACED ON HIGHWAYS WITH EXISTING TRAFFIC STRIPE, LONGITUDINAL SPACINGS SHALL BE ADJUSTED SO THAT THE NON-REFLECTIVE MARKERS FALL ON THE STRIPE.
- AN UNDERCUT BEVEL OF APPROXIMATELY 45° WILL BE ALLOWED ON CERAMIC MARKERS IN LIEU OF DETAIL SHOWN.
- TOLERANCE ON ALL MARKER DIMENSIONS IS 0.003M EXCEPT AS NOTED.
- ADJUST SPACING ACROSS INTERSECTION TO PROVIDE UNIFORM DISTANCE FROM CENTERLINE OF INTERSECTING ROADWAY, PROVIDE MINIMUM OF EIGHT 8M GROUPINGS ON BOTH SIDES OF INTERSECTION.
- CLEAR DISTANCE BETWEEN MARKER AND ADJACENT STRIPE SHALL BE 0.04M.
- ALL DIMENSIONS ARE IN METERS EXCEPT AS NOTED.
- RUMBLE STRIP (DETAIL 19) SHALL BE 6MM THICK, NON-REFLECTIVE, WHITE THERMOPLASTIC STRIPS NORMAL TO THE TRAFFIC FLOW.

FREEWAY STANDARD DETAILS

修正 REVISIONS	交通部台灣區高速公路工程局 TAIWAN AREA FREEWAY CONSTRUCTION BUREAU
項目 ITEM	中華民國 REPUBLIC OF CHINA
日期 DATE	南北高速公路 MIAOLI-TAICHUNG SECTION
	苗栗台中段
	路面標誌及標線 PAVEMENT MARKER AND STRIPING
	中華顧問工程司 CHINA ENGINEERING CONSULTANTS, INC.
日期 DATE	日期 DATE AUG. '74 比例 SCALE NONE 圖號 APPENDIX FT-12

順條詳圖
DETAIL OF STRETCHER

凸頭條詳圖
DETAIL OF HEADER

NOTES

1. WALLS 3.80 OR LESS IN HEIGHT MAY BE CONSTRUCTED WITH NO BATTER
2. UNITS SHOWN IN TABLE ARE FOR INTERMEDIATE PANELS IN COMPUTING A WALL OF SAY 7 PANELS, IT IS NECESSARY TO REMEMBER THAT 7+1 OR 8 VERTICAL ROWS OF HEADERS ARE REQUIRED IN ADDITION, ANOTHER VERTICAL ROW OF HEADERS MUST BE ADDED WHENEVER IN THE CASE OF LONG WALLS, THE WALL IS "BROKEN" AT PANEL POINTS OF APPROXIMATELY 28.8 M.
3. D - DEPTH OF COVER MINIMUM TO BE 0.60, ENGINEER TO ADJUST RETAINING WALL, TO ENSURE DEPTH OF COVER SPECIFIED.
4. ALL DIMENSIONS IN METERS EXCEPT WHERE NOTED OTHERWISE.
5. INTERIOR OF CONCRETE CRIB WALLS TO BE BACK FILLED WITH PERVIOUS MATERIAL, WITH LARGE COBBLES PLACED ADJACENT TO OPENINGS BETWEEN STRETCHERS TO RETAIN BACKFILLED MATERIAL.
6. ALL STRETCHERS SHOULD BE PLACED NEARLY HORIZONTAL THE ELEVATION OF CRIB WALL TO RETAIN INCLINED EMBANKMENT (ESPECIALLY FOR BRIDGE WING WALL EXTENSION) SHALL BE HIGHER THAN THAT OF EMBANKMENT AS SHOWN BELOW :

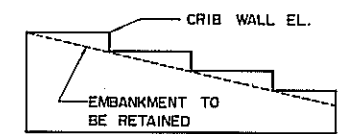

TYPE A

TYPE B

TYPE C

TYPE D

說明:

1. 牆高在 3.8 公尺以下時，牆面得與地面垂直。
2. 框條數量計算表僅示每行凸頭條及順條數，倘牆長須七行，實需順條七行，凸頭條則需另加一行共計八行，牆長 16 行 (28.8 公尺) 為一區段，使用雙行凸頭條分隔。
3. 如圖所示 D 為覆土厚度，最少應為 0.6 公尺，圖示 A 點標高倘與實際情形未盡符合，主管工程師應調整設計，以維持必需之覆土厚度。
4. 所有尺寸除註明者外，均以公尺計。
5. 框條間填回填造水材料，翻接順條間露孔使用較大礫石以防回填材料流失。
6. 框條牆上順條應水平安裝，牆土面傾斜時 (例如用作延伸橋梁翼牆) 應預高程，如上圖所示標高出牆土面度。

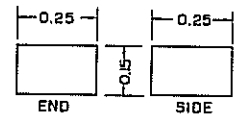

混凝土墊塊詳圖
DETAIL OF FILLER BLOCK

FREEWAY STANDARD DETAILS

交通部台灣區高速公路工程局
TAIWAN AREA FREEWAY CONSTRUCTION BUREAU
中華民國
REPUBLIC OF CHINA
南北高速公路 NORTH-SOUTH FREEWAY
苗栗台中段 MIAOLI-TAICHUNG SECTION
鋼筋混凝土 REINFORCED CONCRETE
框條擋土牆 CRIB WALL
中華顧問工程司 CHINA ENGINEERING CONSULTANTS, INC.
日期 DATE AUG. '74 比例 SCALE NONE 圖號 APPENDIX FT-13

NUMBER OF UNITS REQUIRED FOR ONE INTERMEDIATE 18^M PANEL OF HEIGHTS AS SHOWN

GHT IF ALL	FRONT CRIB				1 ST ANCHOR CRIB			2 ND ANCH. CRIB			ONE COMPLETE PANEL					
	HEADERS		STRETCHERS		ALL W.G.	HDK.	STRETCHERS	HDK.	STRS.	HEADERS	STRETCHERS			BLOCKS		
	2x1x20	2x1x25	2x1x25	15x15	2x15	2x15	2x1x25	25x13	2x15	25x15	2x1x20	25x13x25	15x15	2x15	25x15	25x15x25
99	3															
27	4															
55	4	1														
83	4	2														
111	4	3														
39	4	4														
67	4	5														
95	4	6														
23	4	5	2													
51	4	6														
79	4	6														
107	4	6														
35	4	6	4													
63	4	6														
91	4	13														
19	4	14														
47	4	15														
75	4	16														
103	4	17														
31	4	18														
59	4	19														
87	4	20														
15	4	21														
43	4	22														
71	4	23														
99	4	24														
27	4	25														
55	4	26														
83	4	27														
111	4	28														
TOTAL																

QUANTITY SCHEDULE (參閱各標工程數量計算書)

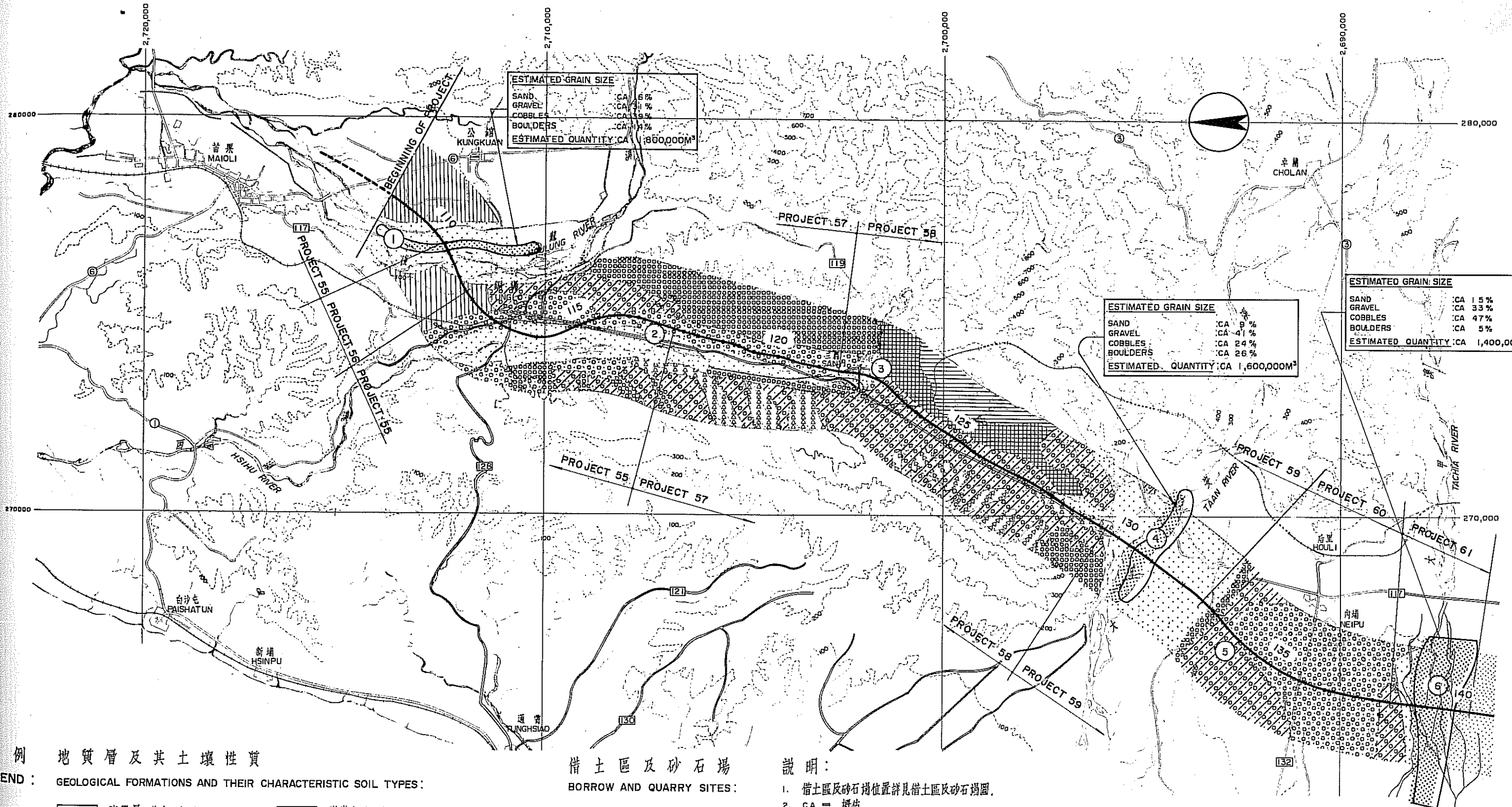

ESTIMATED GRAIN SIZE

SAND	:CA 6%
GRAVEL	:CA 31%
COBBLES	:CA 39%
BOULDERS	:CA 24%

ESTIMATED QUANTITY: CA 1,800,000M³

ESTIMATED GRAIN SIZE

SAND	:CA 9%
GRAVEL	:CA 41%
COBBLES	:CA 24%
BOULDERS	:CA 26%

ESTIMATED QUANTITY: CA 1,600,000M³

ESTIMATED GRAIN SIZE

SAND	:CA 15%
GRAVEL	:CA 33%
COBBLES	:CA 47%
BOULDERS	:CA 5%

ESTIMATED QUANTITY: CA 1,400,000M³

圖例 地質層及其土壤性質

LEGEND : GEOLOGICAL FORMATIONS AND THEIR CHARACTERISTIC SOIL TYPES :

	沖積層 (粘土, 砂, 卵石)		崩崙山層火炎山相 (礫岩)
	台地堆積層 (砂, 卵石)		崩崙山層香山相 (泥岩, 砂岩)
	紅土台地堆積層 (紅土, 砂, 卵石)		桂竹森層 (砂岩)
	崖堆積層 (砂, 卵石, 岩屑)		南莊層 (砂岩, 頁岩)

借土區及砂石場

BORROW AND QUARRY SITES :

	借土區位置		砂石場位置
--	-------	--	-------

說明 :

- 借土區及砂石場位置詳見借土區及砂石場圖。
- CA = 概估
- 土壤縱或橫斷面圖中所示之礫石層, 係包括卵石和大卵石。

NOTE :

- FOR LOCATIONS OF BORROW AND QUARRY SITES SEE THE SHEET OF BORROW AREA & QUARRY SITE.
- CA = ABOUT
- GRAVEL STRATUM AS SHOWN ON THE SOIL PROFILE OR SECTION CONSIST OF COBBLES AND BOULDERS.

修正 REVISIONS	項目 ITEM	日期 DATE

交通部台灣區高速公路工程局
TAIWAN AREA FREEWAY CONSTRUCTION BUREAU
中華民國
REPUBLIC OF CHINA
南北高速公路 NORTH-SOUTH FREEWAY
苗栗台中段 MIAOLI-TAICHUNG SECTION
地質圖 GEOLOGICAL FORMATIONS
借土區及砂石場位置 BORROW AND QUARRY SITES
中華顧問工程司 CHINA ENGINEERING CONSULTANTS INC.
日期 DATE AUG. '74 比例 SCALE AS SHOWN 圖號 SHEET G-1

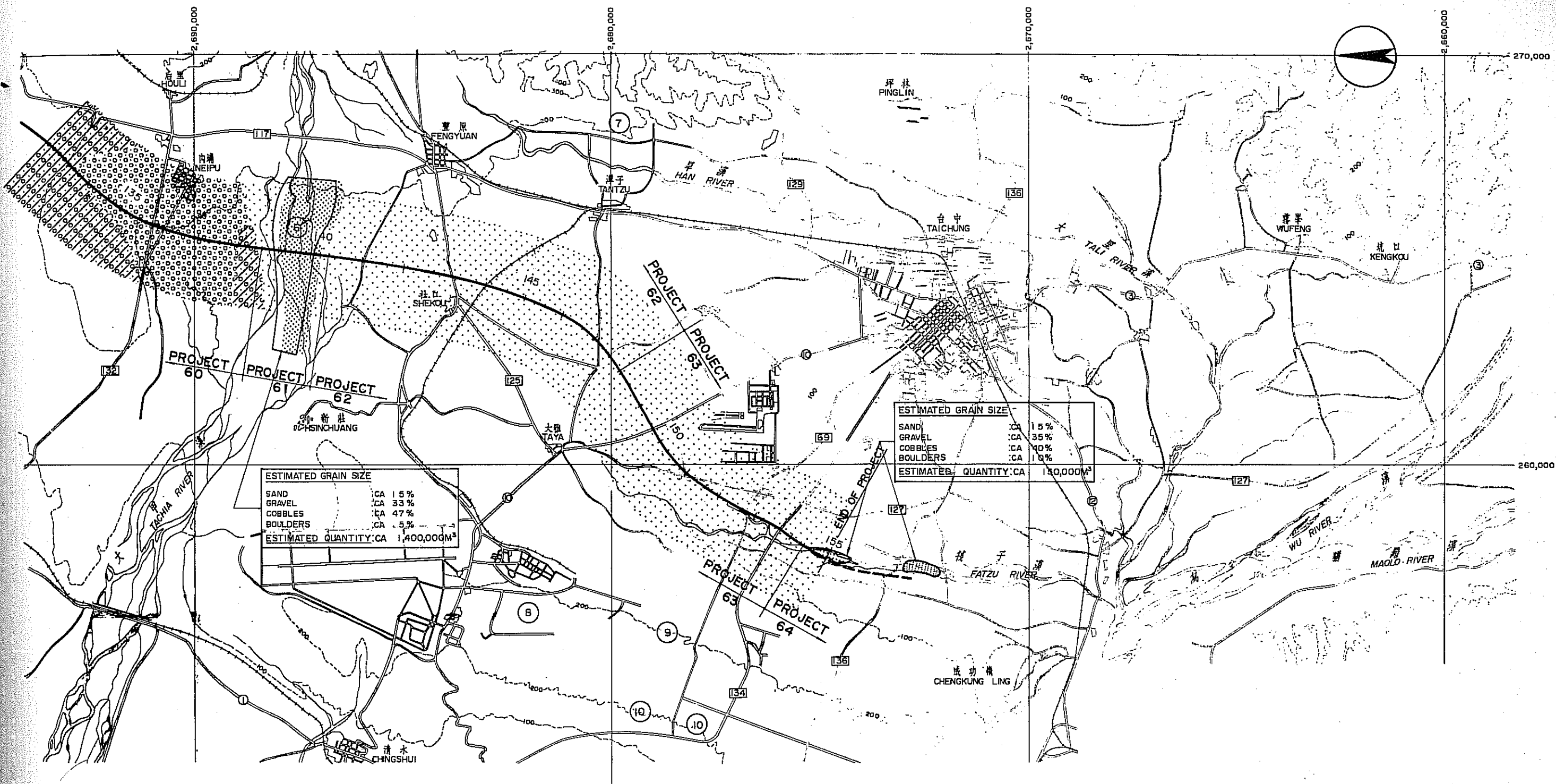

圖例 地質層及其土壤性質

LEGEND : GEOLOGICAL FORMATIONS AND THEIR CHARACTERISTIC SOIL TYPES:

- 沖積層 粘土砂卵石
ALLUVIUM (CLAY, SAND, GRAVEL)
- 台地堆積層 砂卵石
TERRACE DEPOSITES (SAND, GRAVEL)
- 紅土台地堆積層 紅土砂卵石
LATERITIC TERRACE DEPOSITES (LATERITIC, SAND, GRAVEL)

借土區及砂石場
BORROW AND QUARRY SITES:

- 借土區 位置
BORROW SITE
- 砂石場 位置
QUARRY SITE

說明:

1. 借土區及砂石場位置詳見借土區及砂石場圖。
2. CA = 概估
3. 土壤縱或橫斷面圖中所示之礫石層，係包括卵石和大卵石。

NOTE:

1. FOR LOCATIONS OF BORROW AND QUARRY SITES SEE THE SHEET OF BORROW AREA & QUARRY SITE.
2. CA = ABOUT
3. GRAVEL STRATUM AS SHOWN ON THE SOIL PROFILE OR SECTION CONSIST OF COBBLES AND BOULDERS.

SCALE 2500m 0 2500m

修正 REVISIONS		交通部台灣區高速公路工程局 TAIWAN AREA FREEWAY CONSTRUCTION BUREAU 中華民國 REPUBLIC OF CHINA	
項目 ITEM	日期 DATE	南北高速公路 NORTH-SOUTH FREEWAY 苗栗台中段 MIAOLI-TAICHUNG SECTION	
		地質圖 GEOLOGICAL FORMATIONS 借土區及砂石場位置 BORROW AND QUARRY SITES	
		中華顧問工程司 CHINA ENGINEERING CONSULTANTS INC.	
		日期 DATE AUG '74 比例尺 AS SHOWN 圖號 SHEET G-2	

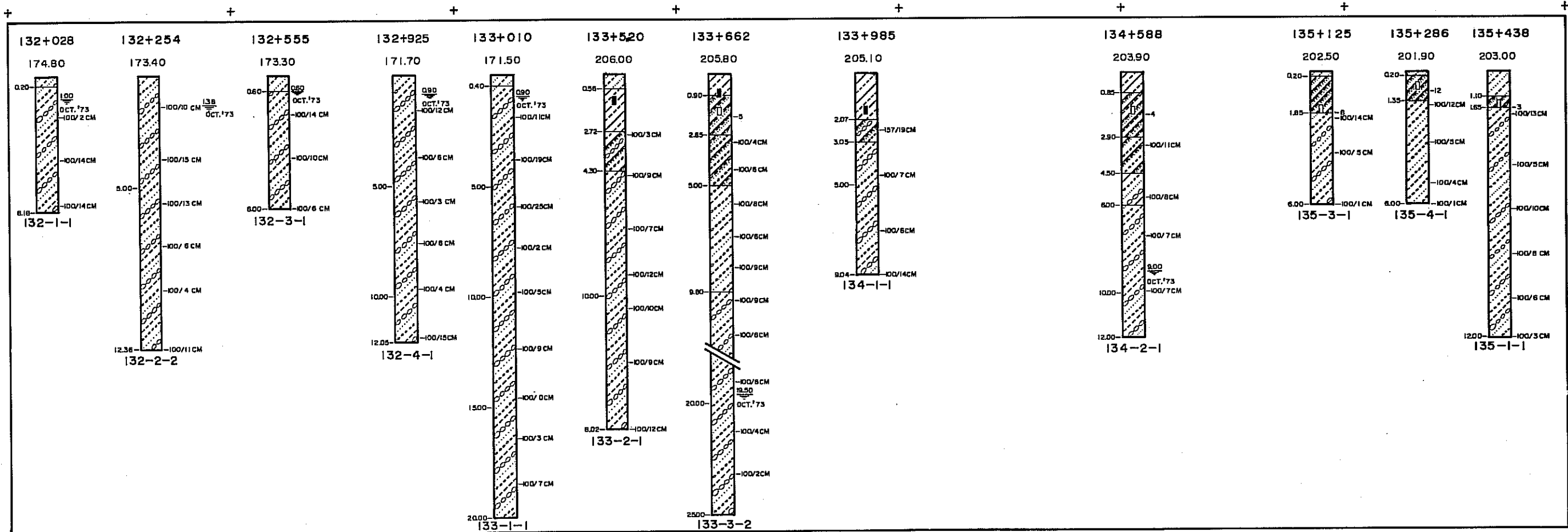
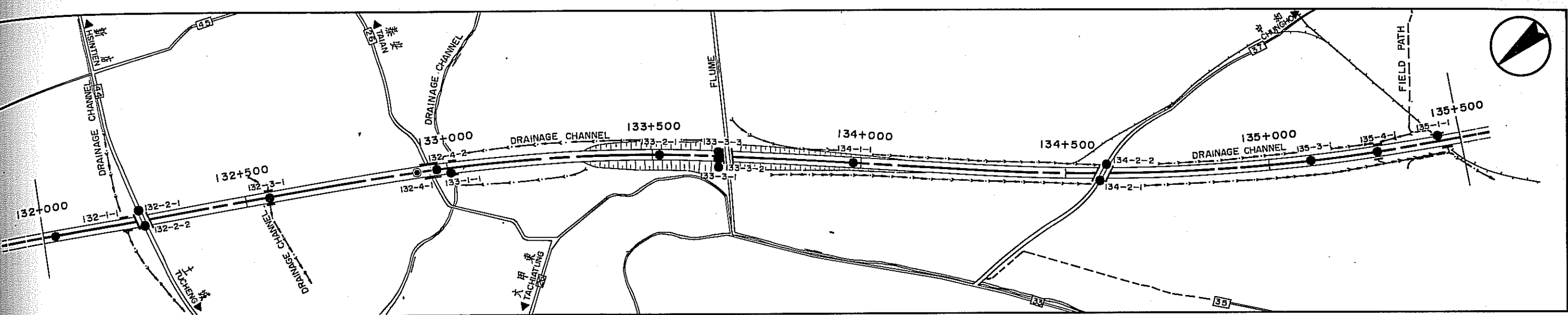

LEGEND: 圖例

SOIL SYMBOL 土壤代表符號	
	砂質粉土, 粉質砂土, 粉質砂質土, 粉質砂質土
	砂
	粉質砂, 砂質粉土
	黏土
	粉質粉土, 粉質粉質土
	粉質粉土, 粉質粉質土
	粉土
	粉質粉土, 粉質粉質土
	粉質粉土, 粉質粉質土
	粉質粉土, 粉質粉質土
	粉質粉土, 粉質粉質土
	粉質粉土, 粉質粉質土
	粉質粉土, 粉質粉質土
	粉質粉土, 粉質粉質土
	粉質粉土, 粉質粉質土
	粉質粉土, 粉質粉質土
	泥岩
	砂岩

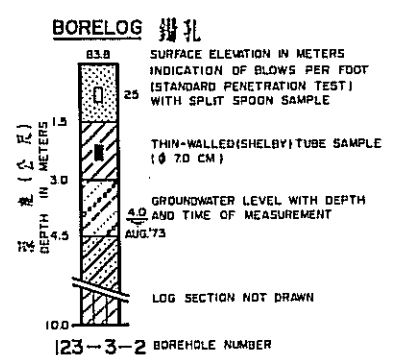

BORELOG 鑽孔
 SURFACE ELEVATION IN METERS
 INDICATION OF BLOWS PER FOOT
 (STANDARD PENETRATION TEST)
 WITH SPLIT SPOON SAMPLE
 THIN-WALLED (SHELBY) TUBE SAMPLE
 (ø 70 CM)
 GROUNDWATER LEVEL WITH DEPTH
 AND TIME OF MEASUREMENT
 LOG SECTION NOT DRAWN
 123-3-2 BOREHOLE NUMBER

NOTE 說明
 1. ● LOCATION AND No. OF BOREHOLE
 136-2-1
 2. ● LOCATION AND No. OF BOREHOLE
 WITH GROUNDWATER GAGE
 144-1-2
 3. SOIL TYPES INDICATED IN THE
 BOREHOLES ARE BASED ON
 VISUAL CLASSIFICATION AND
 TEST RESULTS
 4. FOR THE COMPLETE LOGS AS
 WELL AS THOSE NOT SHOWN
 IN THIS PROFILE REFER TO
 SPECIAL GEOTECHNICAL PLANS
 SHEET G-7, G-8

SCALES
 VERTICAL 0 5m 250
 HORIZONTAL 0 250m

修正	REVISIONS	項目	ITEM	日期	DATE

交通部台灣區高速公路工程局
 TAIWAN AREA FREEWAY CONSTRUCTION BUREAU
 中華民國
 南北高速公路
 苗栗台中段
 NORTH-SOUTH FREEWAY
 MIAOLI-TAICHUNG SECTION
 平面及土壤縱剖面
 PLAN AND SOIL PROFILE
 STA. 132+000 TO STA. 135+500
 中華顧問工程司
 CHINA ENGINEERING CONSULTANTS, INC.
 日期 DATE AUG. '74 圖號 SCALE AS SHOWN 圖號 SHEET G-4

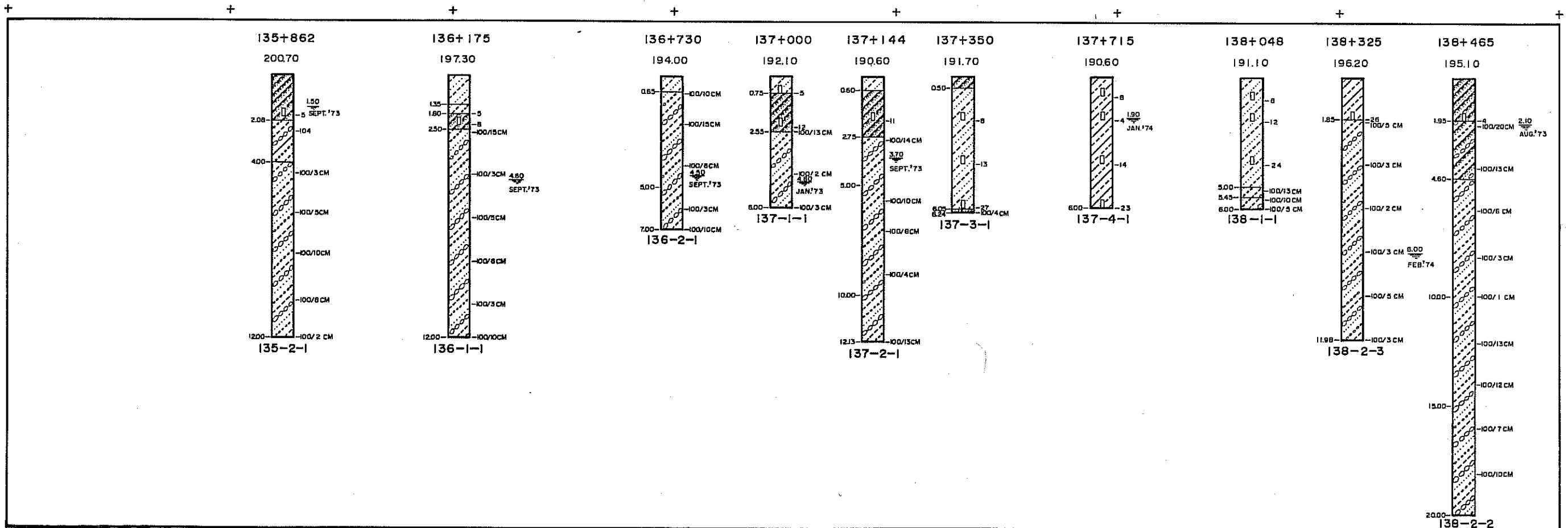
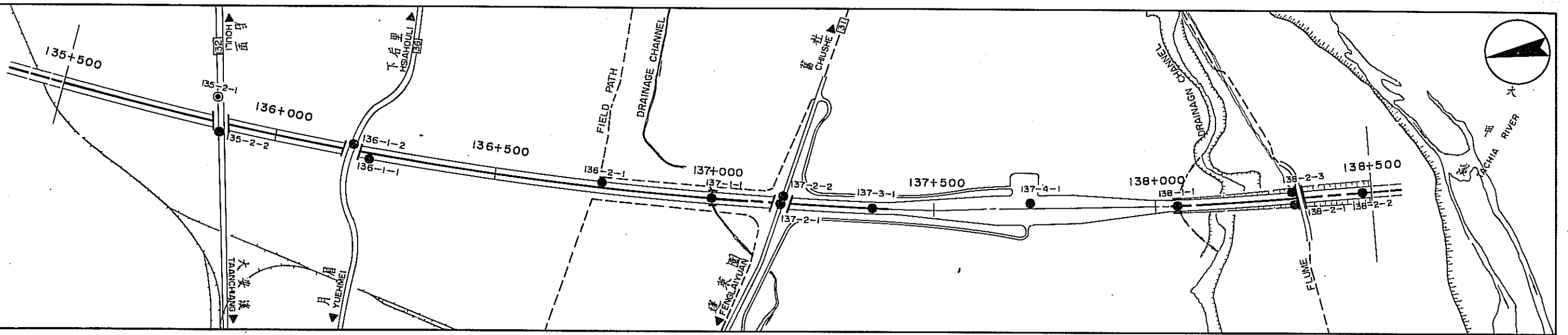

LEGEND: 圖例

SOIL SYMBOL 土壤代表符號	
	粉質粘土 SILTY, SANDY CLAY
	粘質粉土 CLAYEY, SANDY SILT
	粉質砂 SILTY SAND
	粉質粉土 SANDY SILT
	粘土 CLAY
	粉質粘土 SILTY CLAY
	砂質粘土 SANDY CLAY
	粉土 SILT
	砂質粉土 SANDY, SILTY GRAVEL
	粉質砂土 SILTY, SANDY GRAVEL
	砂質粘土 SANDY, CLAYEY GRAVEL
	粘質砂土 CLAYEY, SANDY GRAVEL
	粉質砂土 SILTY GRAVEL
	粘質砂土 CLAYEY GRAVEL
	砂質砂土 SANDY GRAVEL
	粘板岩 CLAYSTONE
	砂岩 SANDSTONE

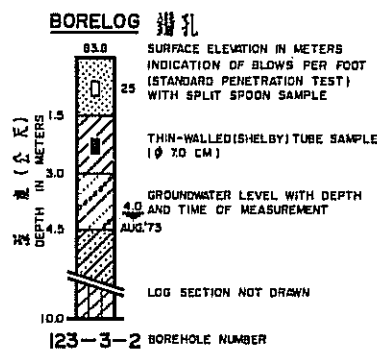

BORELOG 鑽孔
 SURFACE ELEVATION IN METERS
 INDICATION OF BLOWS PER FOOT
 (STANDARD PENETRATION TEST)
 WITH SPLIT SPOON SAMPLE
 THIN-WALLED(SHELVY) TUBE SAMPLE
 (1 7/8 CM)
 GROUNDWATER LEVEL WITH DEPTH
 AND TIME OF MEASUREMENT
 LOG SECTION NOT DRAWN
 BOREHOLE NUMBER 123-3-2

NOTE 說明
 1. LOCATION AND No. OF BOREHOLE WITH GROUNDWATER GAGE
 2. LOCATION AND No. OF BOREHOLE WITH SPLIT SPOON SAMPLE
 3. SOIL TYPES INDICATED IN THE BOREHOLES ARE BASED ON VISUAL CLASSIFICATION AND TEST RESULTS
 4. FOR THE COMPLETE LOGS AS WELL AS THOSE NOT SHOWN IN THIS PROFILE REFER TO SPECIAL GEOTECHNICAL PLANS SHEET G-8, G-9

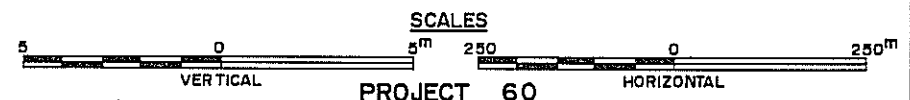

修正	REVISIONS	項目	ITEM	日期	DATE

交通部台灣區高速公路工程局
 TAIWAN AREA FREEWAY CONSTRUCTION BUREAU
 中華民國
 中華人民共和國
 南北高速公路
 NORTH-SOUTH FREEWAY
 苗栗台中段
 MIAOLI-TAICHUNG SECTION
 平面及土壤縱剖面
 PLAN AND SOIL PROFILE
 STA.135+500 TO STA.138+500
 中華顧問工程司
 CHINA ENGINEERING CONSULTANTS, INC.
 日期 DATE AUG. '74 比例 SCALE AS SHOWN 圖號 SHEET G-5

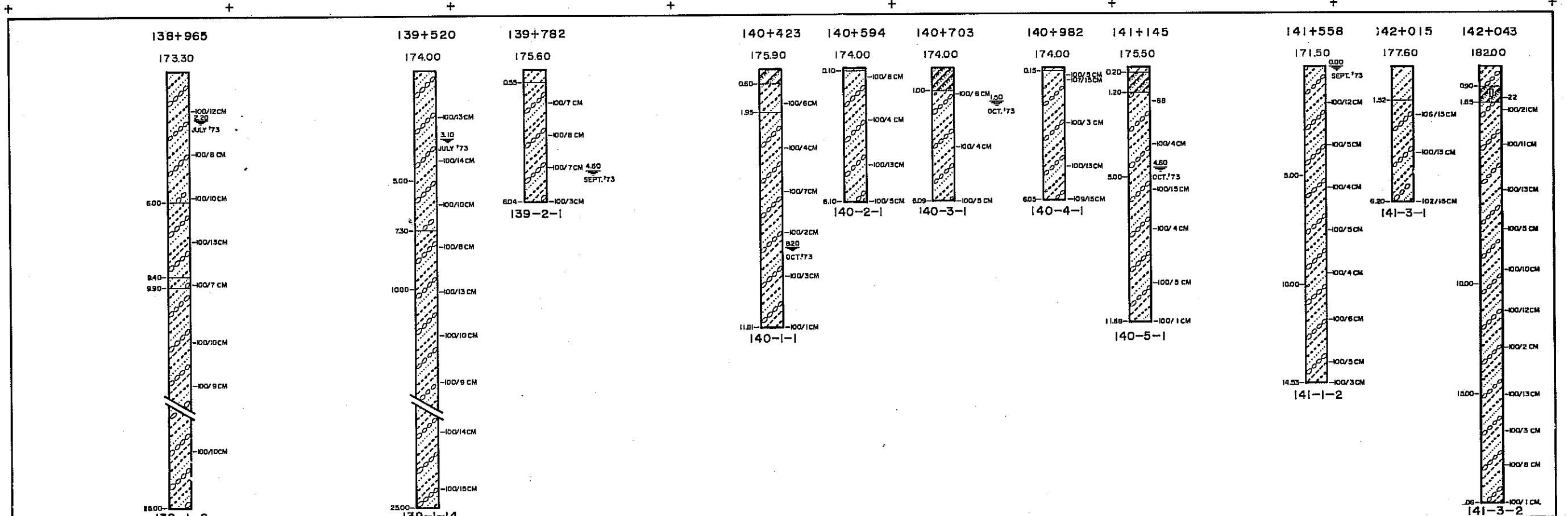
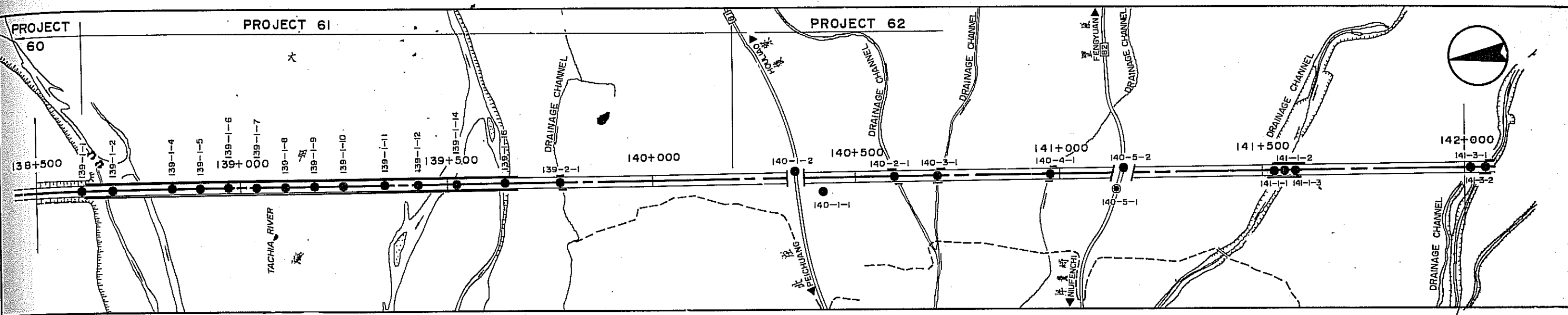

LEGEND: 圖例

SOIL SYMBOL 土壤代表符號	
SILTY, SANDY CLAY CLAYEY, SANDY SILT CLAYEY, SILTY SAND	淤泥、粉質黏土 黏土、粉質淤泥 黏土、淤泥質粉
SAND	砂
SILTY SAND SANDY SILT	淤泥質砂 粉質淤泥
CLAY	黏土
SILTY CLAY CLAYEY SILT	淤泥質黏土 黏土質淤泥
SANDY CLAY CLAYEY SAND	粉質黏土 黏土質粉
SILTY GRAVEL GRAVELLY SILT	淤泥質礫石 礫石質淤泥
CLAYEY GRAVEL GRAVELLY CLAY	黏土質礫石 礫石質黏土
SANDY GRAVEL GRAVELLY SAND	粉質礫石 礫石質粉
CLAYSTONE	泥質
SANDSTONE	砂質
SILTY GRAVEL GRAVELLY SILT	粉質、淤泥質礫石 黏土、粉質礫石
SANDY, SILTY GRAVEL SILTY, SANDY GRAVEL	粉質、淤泥質礫石 黏土、粉質礫石
SANDY, CLAYEY GRAVEL CLAYEY, SANDY GRAVEL	粉質、黏土質礫石 黏土、粉質礫石
CLAYEY, SILTY GRAVEL SILTY, CLAYEY GRAVEL	粉質、淤泥質礫石 淤泥、黏土質礫石

BORELOG 鑽孔

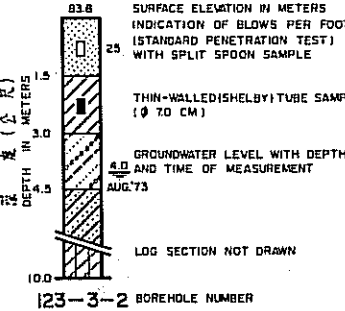

SURFACE ELEVATION IN METERS
INDICATION OF BLOWS PER FOOT
(STANDARD PENETRATION TEST)
WITH SPLIT SPOON SAMPLE

地而高程(公尺)
標準貫入試驗(重錘)式試驗

THIN-WALLED(SHIELD)TUBE SAMPLE
(Ø 70 CM)

薄壁取樣(直徑70公分)

GROUNDWATER LEVEL WITH DEPTH
AND TIME OF MEASUREMENT

地下水位及測量時間

LOG SECTION NOT DRAWN

剖面未圖示

123-3-2 BOREHOLE NUMBER

孔號

NOTE 說明

- LOCATION AND NO. OF BOREHOLE WITH GROUNDWATER GAGE
136-2-1
鑽孔之位置及量水
- LOCATION AND NO. OF BOREHOLE WITH GROUNDWATER GAGE
144-1-2
設置地下水尺鑽孔位置及量水
- SOIL TYPES INDICATED IN THE BOREHOLES ARE BASED ON VISUAL CLASSIFICATION AND TEST RESULTS.
鑽孔之土壤種類係根據目視分類及試驗結果
- FOR THE COMPLETE LOGS AS WELL AS THOSE NOT SHOWN IN THIS PROFILE REFER TO SPECIAL GEOTECHNICAL PLANS
本圖之完整鑽孔剖面請參閱

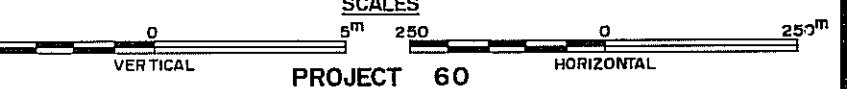

REVISIONS	
項目 ITEM	日期 DATE

交通部台灣區高速公路工程局
TAIWAN AREA FREEWAY CONSTRUCTION BUREAU
中華民國
南北高速公路 NORTH-SOUTH FREEWAY
苗栗台中段 MIAOLI-TAICHUNG SECTION

平面及土壤縱剖面 PLAN AND SOIL PROFILE
STA.138+500 TO STA.142+000

中華顧問工程司 CHINA ENGINEERING CONSULTANTS, INC.
日期 DATE AUG. '74 比例 SCALE AS SHOWN 圖號 SHEET G-6

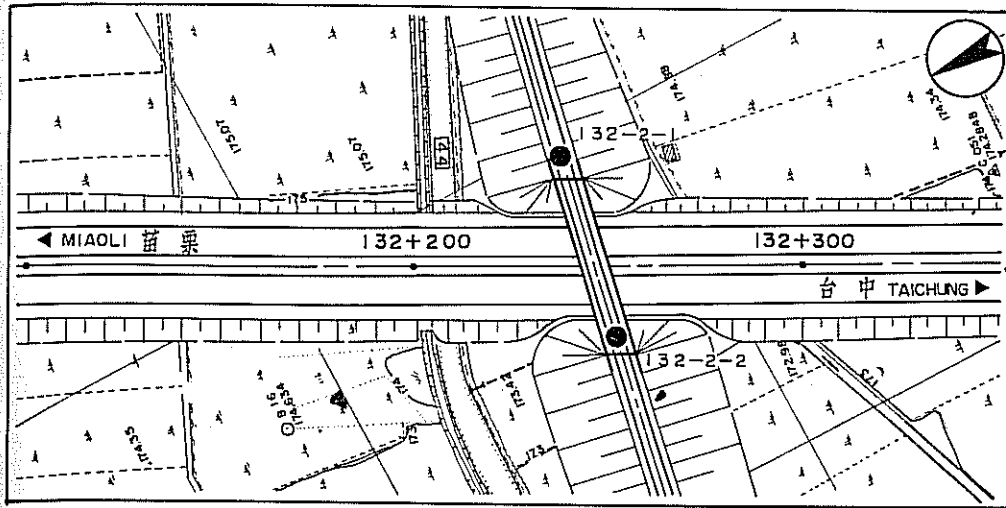

單車道跨越橋
1-LANE OVERCROSSING
STA. 132+246.82

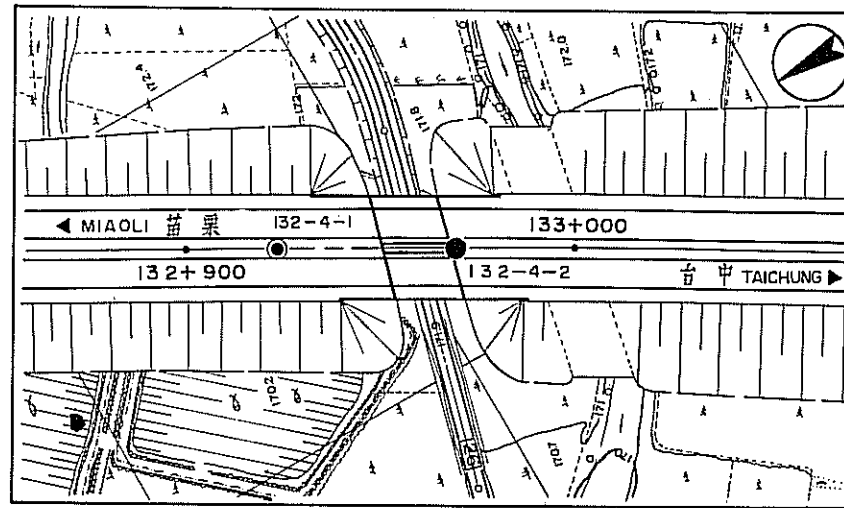

雙車道穿越橋
2-LANE UNDERCROSSING
STA. 132+959.29

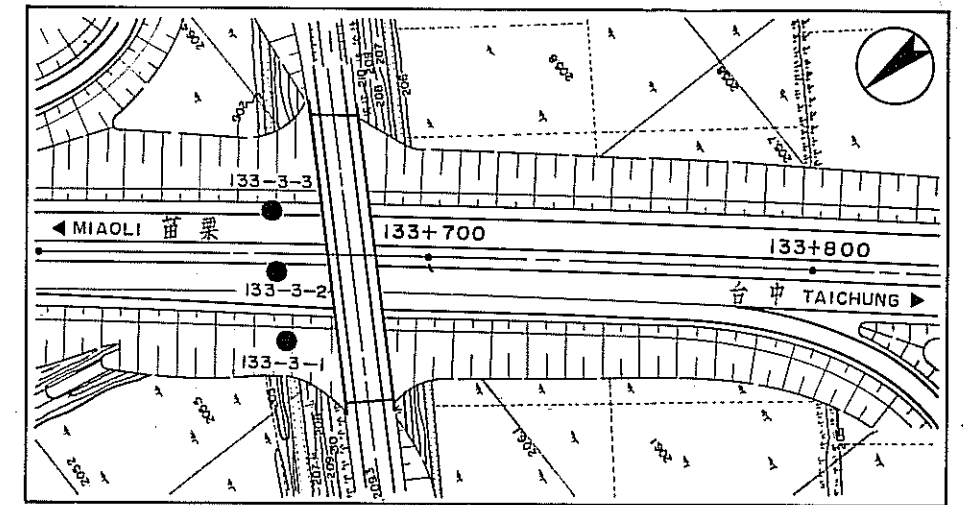

渡槽
FLUME
STA. 133+680.50

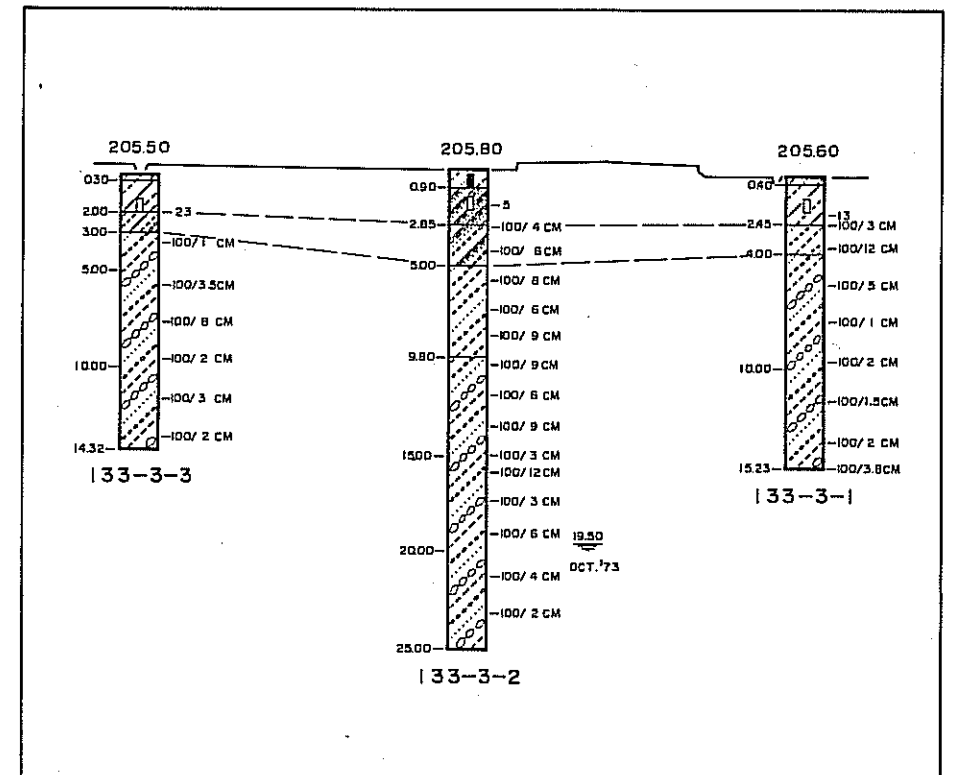
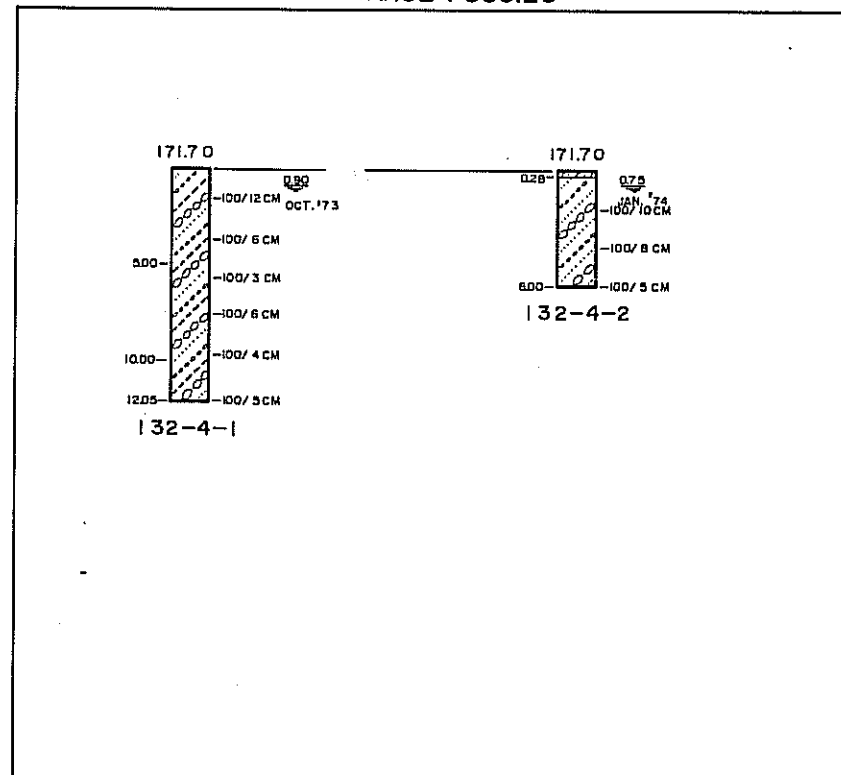
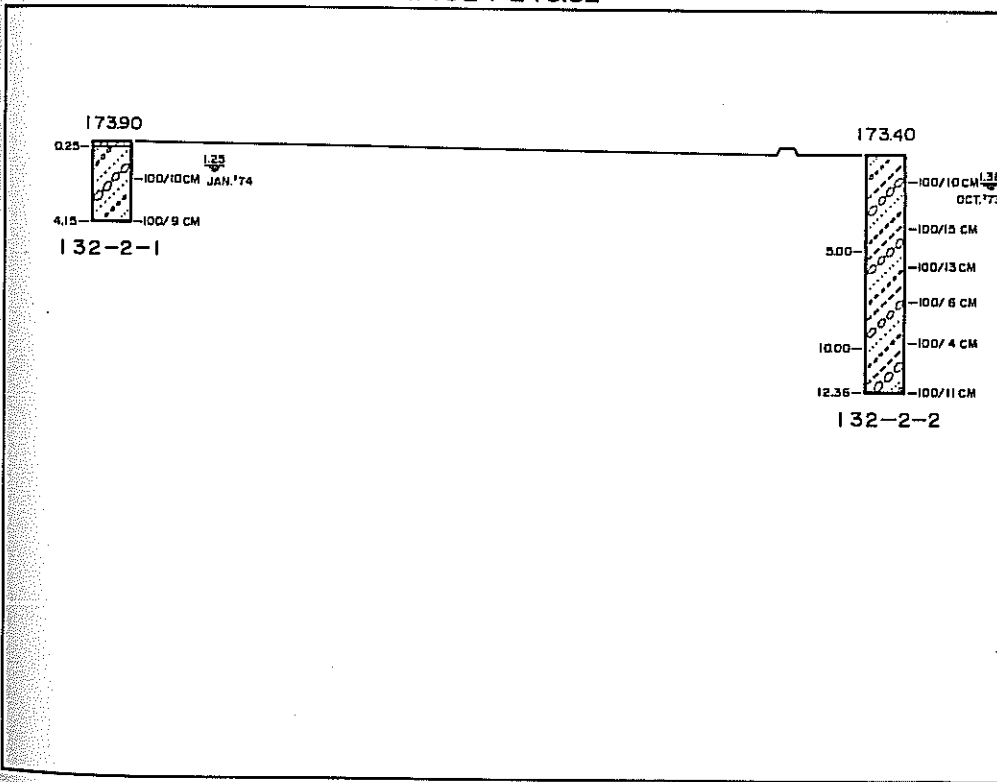

LEGEND: 圖例

CLAY.	黏土
CLAYEY SILT.	黏土質泥
SILTY CLAY.	泥質黏土
SANDY SILT.	泥質砂
SANDY SILT.	砂質泥
SANDY SILTY GRAVEL.	砂質泥質礫石
COBBLE BOULDER.	礫石
SANDY GRAVEL COBBLE BOULDER.	砂質礫石
CLAYEY SILT SAND.	黏土質泥砂
SILTY CLAY SAND.	泥質黏土砂
SANDY CLAY SILT.	砂質黏土
SANDY SILTY GRAVEL COBBLE.	砂質泥質礫石
CLAYEY SILT SAND GRAVEL.	黏土質泥砂礫石
SILTY CLAY SAND GRAVEL.	泥質黏土砂礫石
SANDY CLAY SILT GRAVEL.	砂質黏土礫石

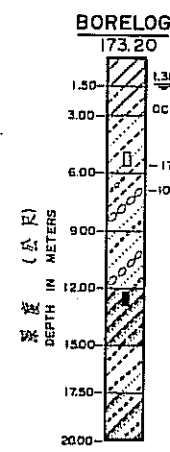

BORELOG 鑽孔
SURFACE ELEVATION IN METERS. 地面高程 (公尺)
GROUNDWATER LEVEL WITH DEPTH AND TIME OF MEASUREMENT. 地下水位及測量時間
BLOWS PER FOOT. (STANDARD PENETRATION TEST) WITH SPLIT SPOON SAMPLE. 標準貫入試驗 N 值及開裂式取樣
THIN-WALLED (SHELBY) TUBE SAMPLE. 薄管取樣 (直徑 7 公分)

NOTE: 說明

- LOCATION AND No. OF BOREHOLE. 鑽孔之位置及編號
132-2-2
- LOCATION AND No. OF BOREHOLE WITH GROUNDWATER GAGE. 裝置地下水尺之鑽孔位置及編號
132-4-1
- SOIL TYPES INDICATED IN THE BOREHOLES ARE BASED ON VISUAL CLASSIFICATION AND TEST RESULT. 鑽孔之土壤分類係根據現場分類及試驗結果

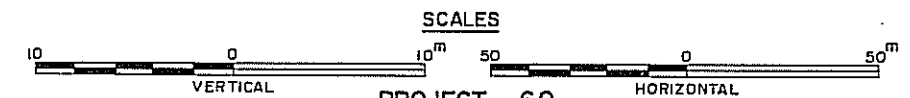

修正	REVISIONS	項目	日期	DATE

交通部台灣區高速公路工程局
TAIWAN AREA FREEWAY CONSTRUCTION BUREAU
中華民國
南北高速公路 NORTH-SOUTH FREEWAY
苗栗台中段 MIAOLI-TAICHUNG SECTION

結構物土壤斷面 SOIL SECTIONS AT STRUCTURES
中華顧問工程司 CHINA ENGINEERING CONSULTANTS, INC.
日期 DATE AUG. '74 比例 SCALE AS SHOWN 圖號 SHEET G-7

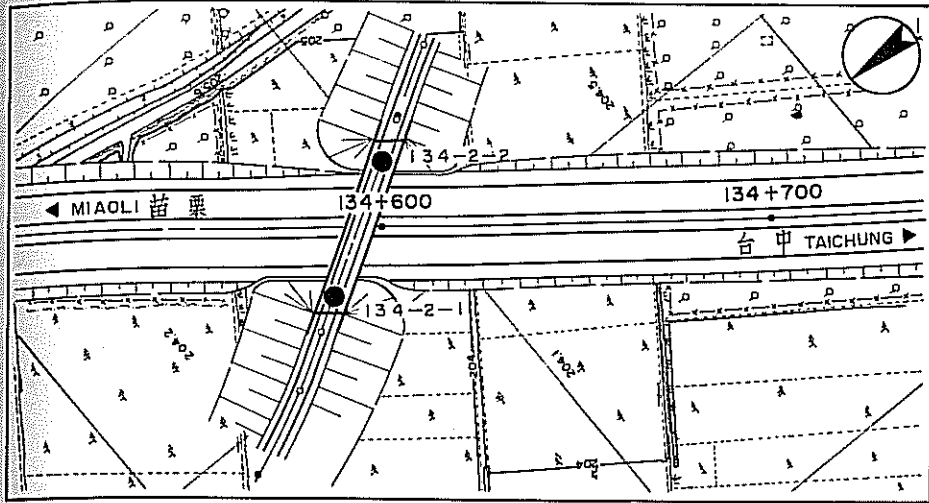

單車道跨越橋
1-LANE OVERCROSSING
STA. 134+593.90

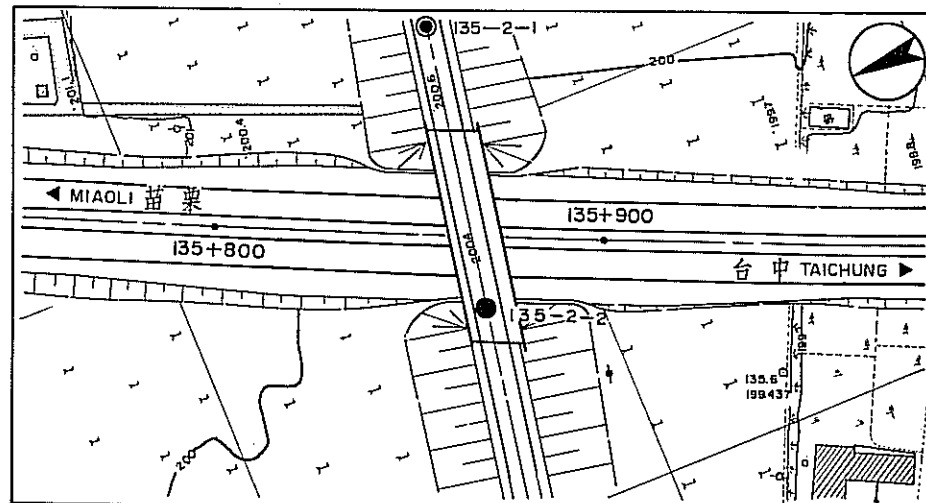

雙車道跨越橋
2-LANE OVERCROSSING
STA. 135+864.91

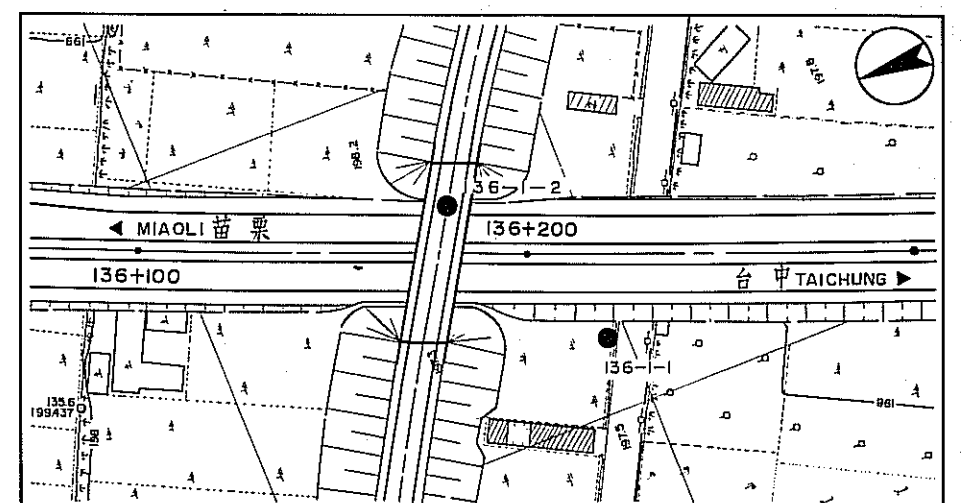

雙車道跨越橋
2-LANE OVERCROSSING
STA. 136+177.38

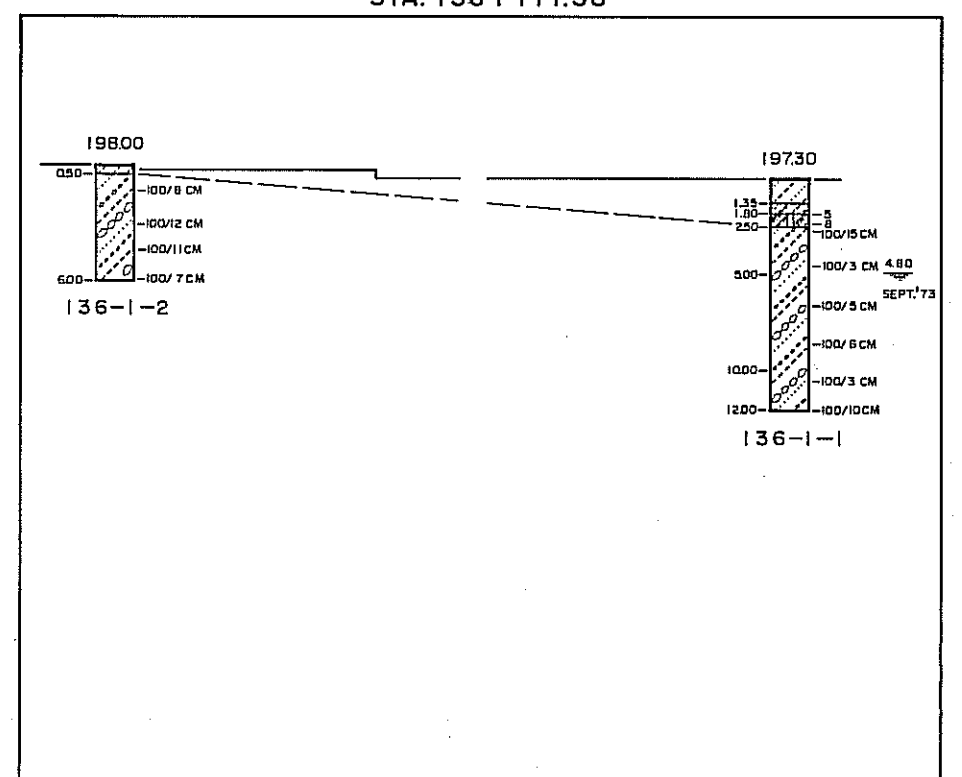
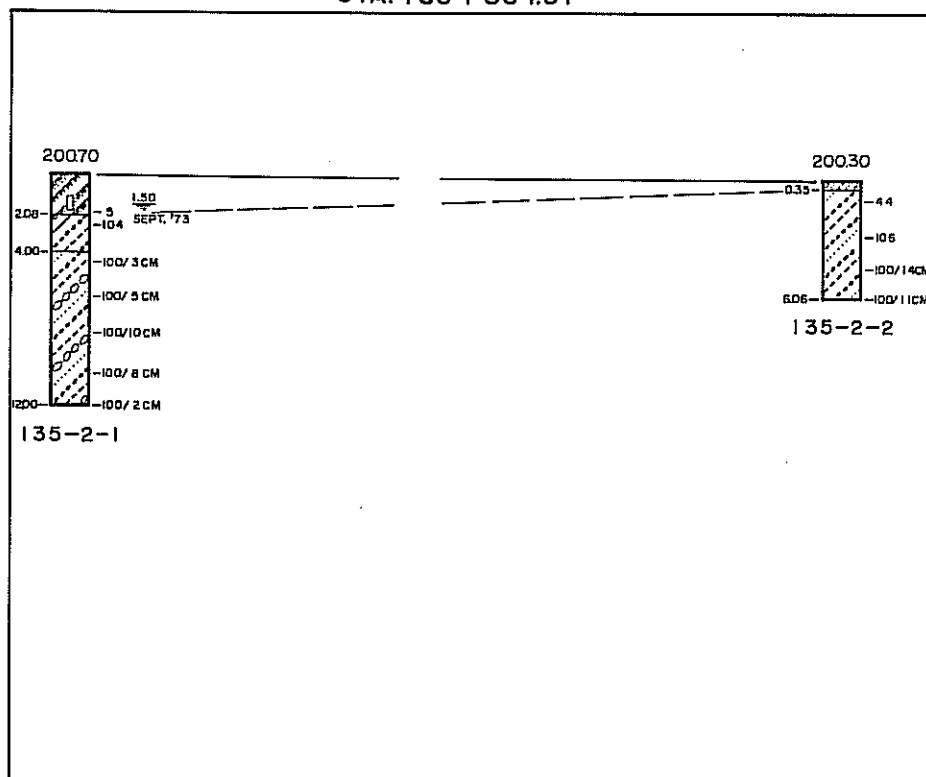
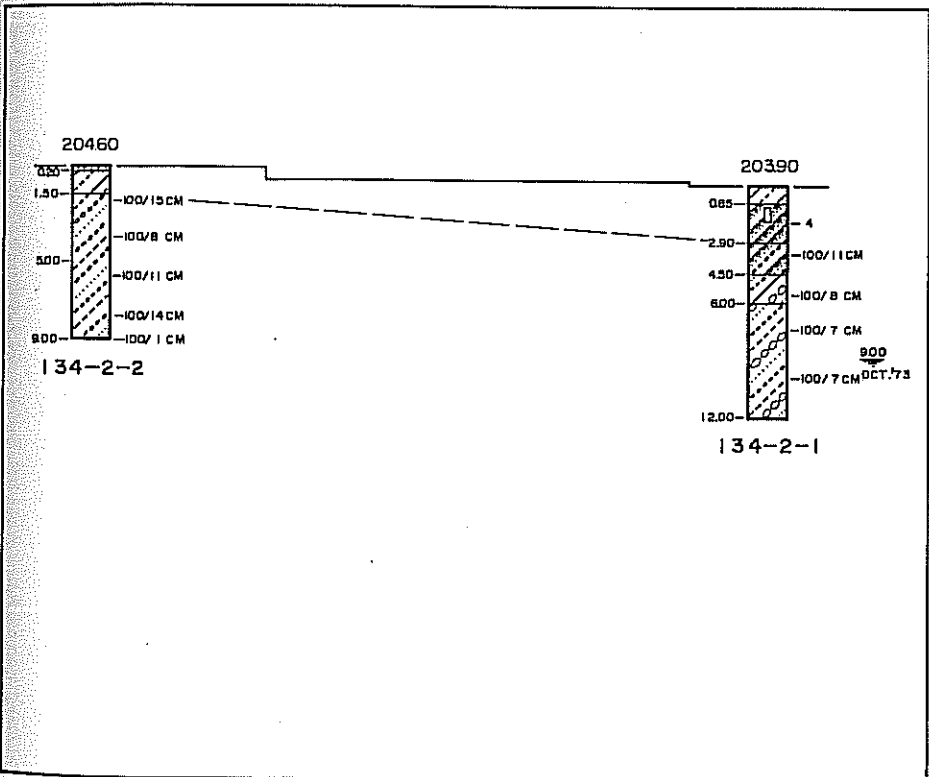

LEGEND: 圖例

SILT.	泥
SANDY SILT.	泥砂
SILTY SAND.	砂泥
CLAYEY SILT.	粘泥
SILTY CLAY.	泥砂
CLAYEY SILT, SAND.	粘泥砂
SILTY CLAY, SAND.	砂泥粘
SANDY SILT, CLAY.	砂泥粘
CLAYEY SILT, SAND, GRAVEL.	粘泥砂石
SANDY SILT, CLAY, GRAVEL.	砂泥粘石
SILTY CLAY, SAND, GRAVEL.	砂泥粘石
CLAYEY SANDY GRAVEL.	粘砂石
COBBLE BOULDER.	礫石
CLAYEY SILTY GRAVEL.	粘砂石
COBBLE BOULDER.	礫石
SANDY SILTY GRAVEL.	砂石
COBBLE.	礫石
SANDY SILTY GRAVEL.	砂石
COBBLE BOULDER.	礫石

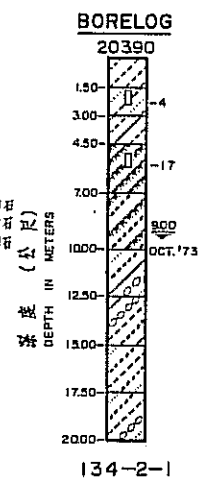

鑽孔
SURFACE ELEVATION IN METERS. 地面高度 (公尺)
BLOWS PER FOOT (STANDARD PENETRATION TEST) 標準貫入試驗 N 值及開創式取樣
GROUNDWATER LEVEL WITH DEPTH. AND TIME OF MEASUREMENT. 地下水位及測量深度
BOREHOLE NUMBER. 孔號

NOTE:

- LOCATION AND No. OF BOREHOLE. 134-2-1
- LOCATION AND No. OF BOREHOLE WITH GROUNDWATER GAGE. 135-2-1
- SOIL TYPES INDICATED IN THE BOREHOLES ARE BASED ON VISUAL CLASSIFICATION AND TEST RESULT.

說明

鑽孔之位置及編號
裝置地下水尺鑽孔位置及編號
鑽孔之土壤分類係根據現場分類及試驗結果

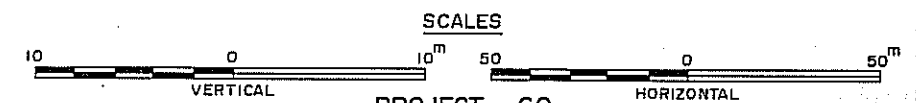

修正	REVISIONS	項目	ITEM	日期	DATE

交通部台灣區高速公路工程局
TAIWAN AREA FREEWAY CONSTRUCTION BUREAU
中華民國
REPUBLIC OF CHINA
南北高速公路 NORTH-SOUTH FREEWAY
苗栗-台中段 MIAOLI-TAICHUNG SECTION
結構物土壤斷面 SOIL SECTIONS
AT STRUCTURES
中華顧問工程司 CHINA ENGINEERING CONSULTANTS, INC.
日期 DATE AUG. '74 比例 SCALE AS SHOWN 圖號 SHEET G-B

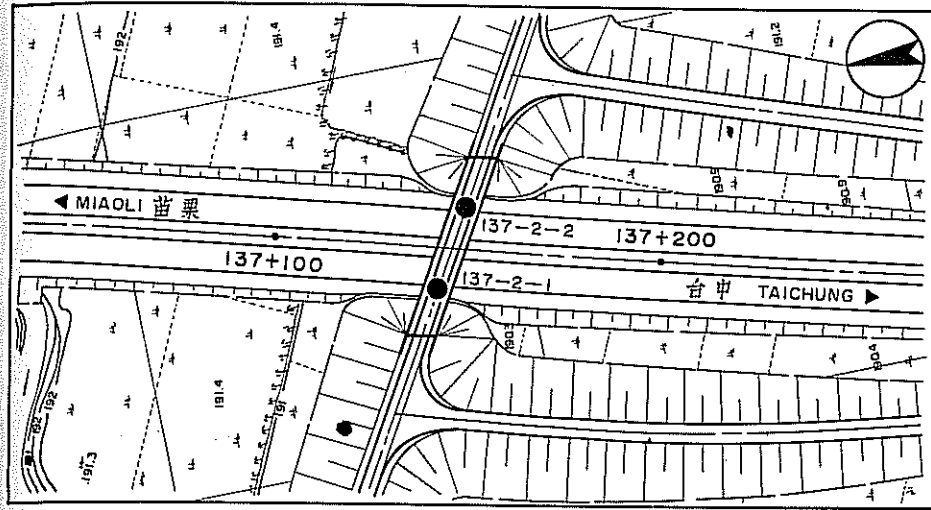

單車道跨越橋
1-LANE OVERCROSSING
STA. 137+145.98

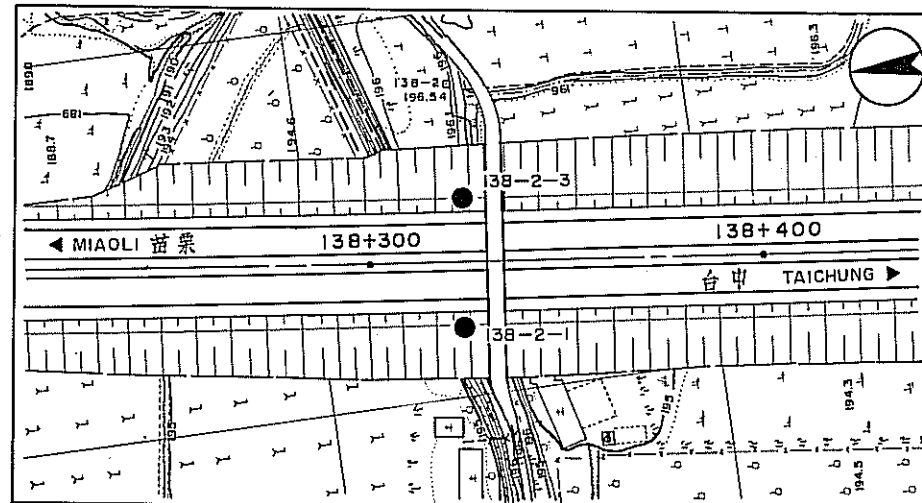
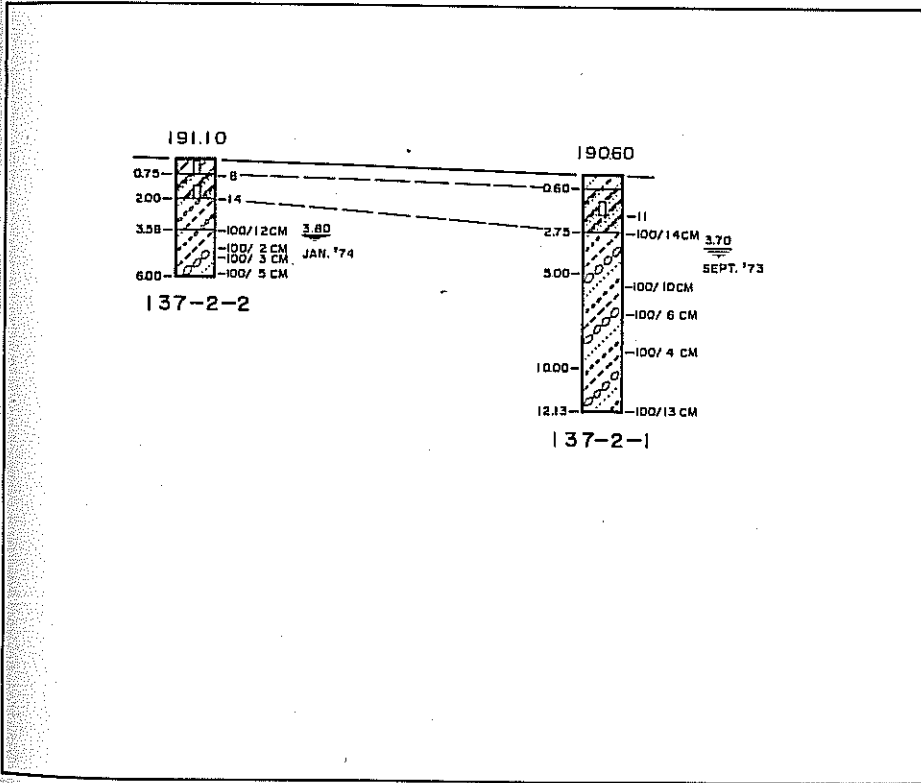

渡槽
FLUME
STA. 138+332

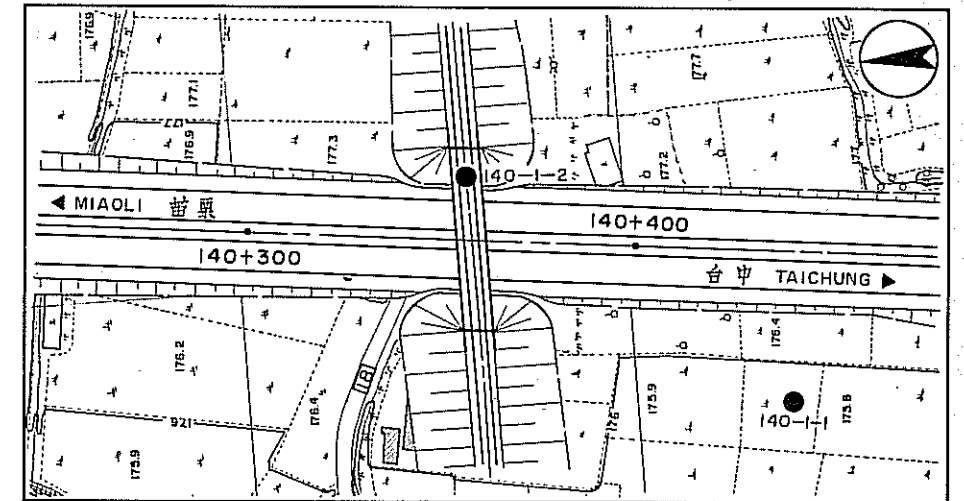
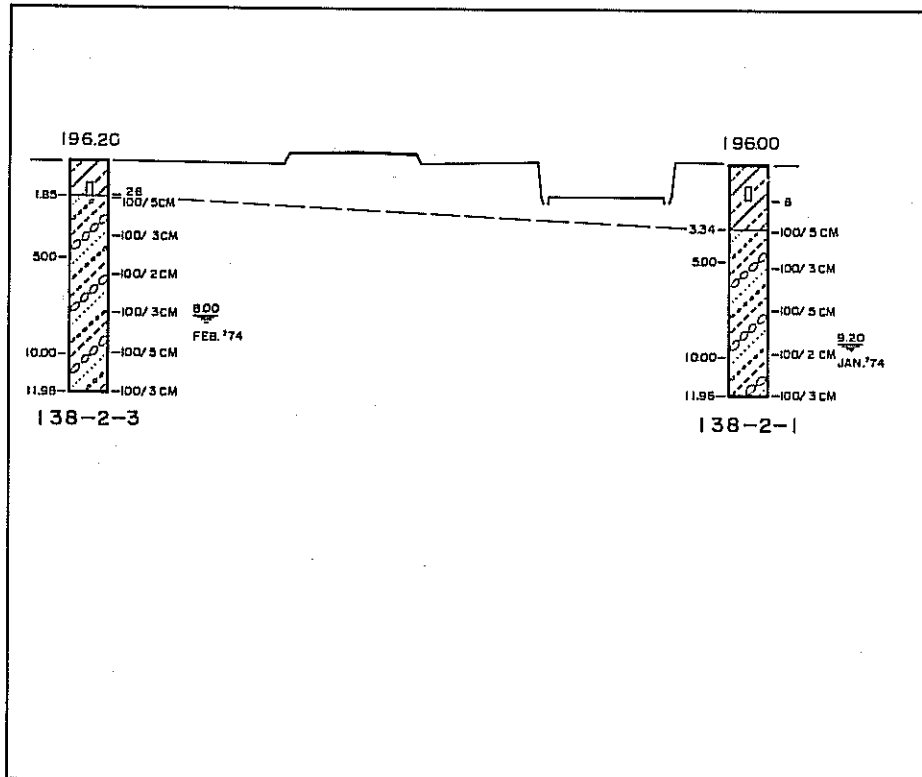

單車道跨越橋
1-LANE OVERCROSSING
STA. 140+357.22

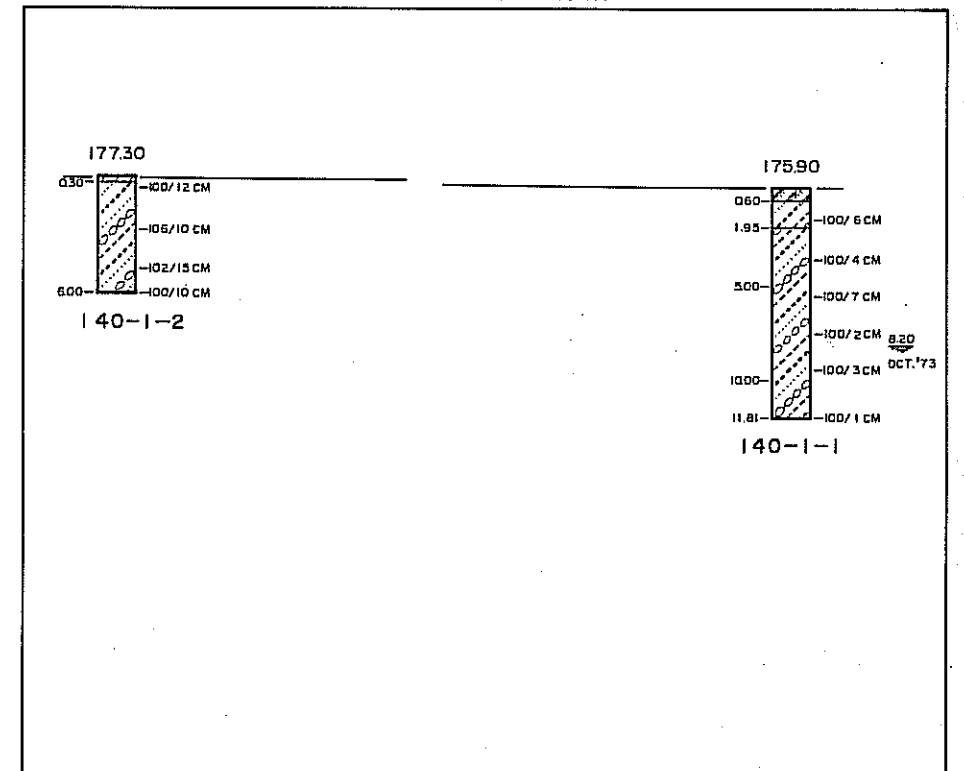

LEGEND: 圖例

CLAYEY SILT SAND.	粘土質泥砂
CLAYEY SAND SILT.	粘土質砂泥
SILTY CLAY SAND.	泥質粘土砂
SILTY SAND.	泥質砂
SANDY SILT.	砂質泥
CLAYEY SAND.	粘土質砂
SANDY CLAY.	砂質粘土
CLAYEY SILT.	粘土質泥
SILTY CLAY.	泥質粘土
SILT.	泥
SILTY SANDY GRAVEL	泥質砂質碎石
SILTY SANDY GRAVEL COBBLE BOULDER.	泥質砂質碎石礫石

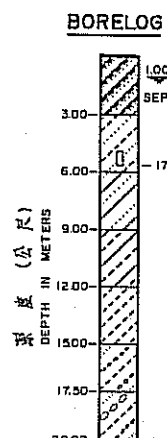

BORELOG 鑽孔

SURFACE ELEVATION IN METERS.
GROUNDWATER LEVEL WITH DEPTH.
AND TIME OF MEASUREMENT.

指面高程(公尺)
指下水位及測量時間

BLOWS PER FOOT.
(STANDARD PENETRATION TEST)
WITH SPLIT SPOON SAMPLE.

標準貫入試驗N值
及開裂式取樣

137-2-1 BOREHOLE NUMBER.

孔號

NOTE:

1. LOCATION AND No. OF BOREHOLE.
137-2-1

3. SOIL TYPES INDICATED IN THE BOREHOLES ARE BASED ON VISUAL CLASSIFICATION AND TEST RESULT.

說明

鑽孔之位置及編號

鑽孔之土壤分類係根據
現場分類及試驗結果

SCALES

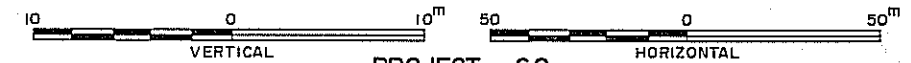

修正	REVISIONS	項目	ITEM	日期	DATE

交通部台灣區高速公路工程局
TAIWAN AREA FREEWAY CONSTRUCTION BUREAU
中華民國
南北高速公路 NORTH-SOUTH FREEWAY
苗栗台中段 MIAOLI-TAICHUNG SECTION

結構物土壤斷面 SOIL SECTIONS
AT STRUCTURES

中華顧問工程司 CHINA ENGINEERING CONSULTANTS, INC.

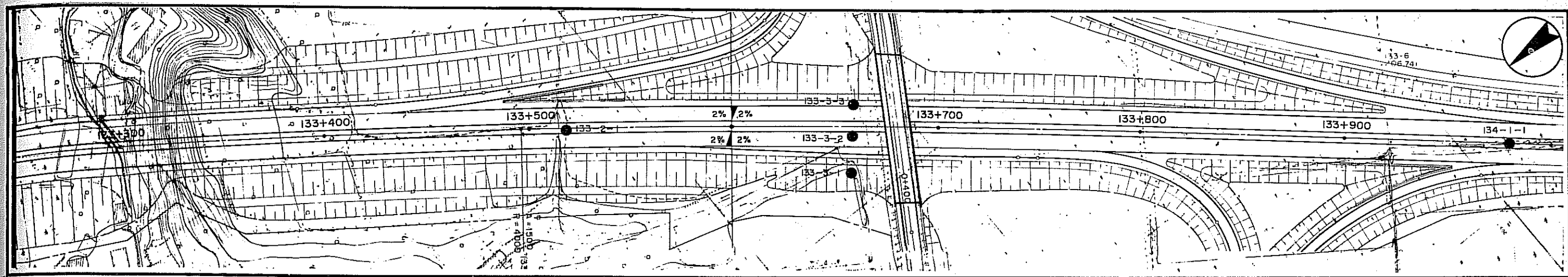

平面圖
PLAN

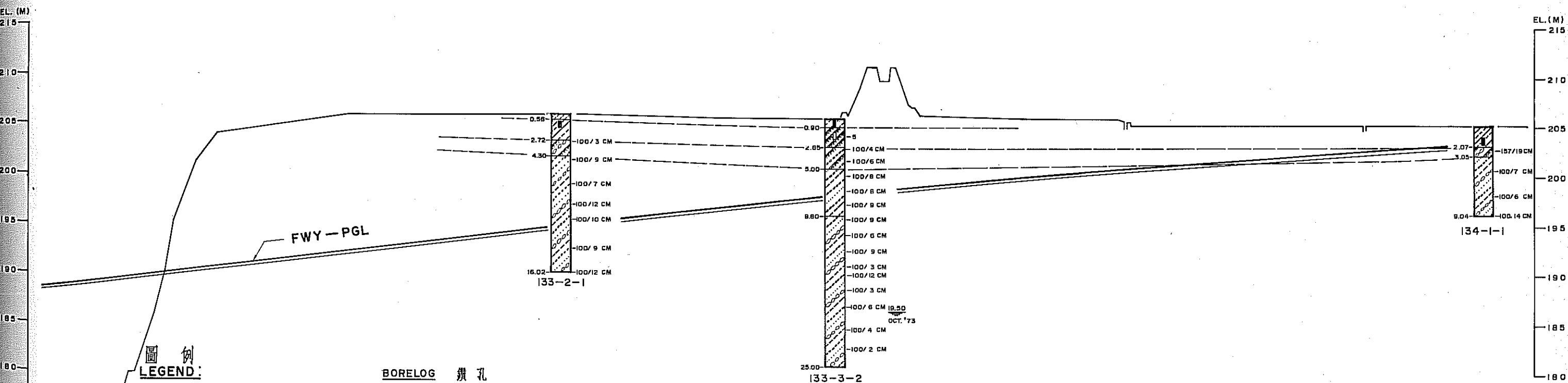

縱斷面圖
LONGITUDINAL SECTION

圖例
LEGEND:

SILT	泥
SILTY SAND SANDY SILT	泥質砂 砂質泥
CLAYEY SILT SAND SILTY SAND CLAY SANDY CLAY SILT	粘土質泥砂 泥質砂粘土 砂質粘土泥
SILTY SAND CLAY GRAVEL COBBLE BOULDER	泥質砂粘土 礫石粗石
SILTY SAND GRAVEL	泥質砂礫石
SILTY SAND GRAVEL COBBLE BOULDER	泥質砂礫石 粗石

BORELOG 鑽孔

THIN-WALLED (SHELBY) TUBE SAMPLE 薄管取樣 (直徑 7 公分)
Ø 7.0 CM

BLOWS PER FOOT (STANDARD PENETRATION TEST) WITH SPLIT SPOON SAMPLE 標準貫入試驗 N 值及開裂式取樣

GROUNDWATER LEVEL WITH DEPTH AND TIME OF MEASUREMENT 地下水位及測量時間

DEPTH IN METERS 深度 (公尺)

BOREHOLE NUMBER 孔號

NOTE

- LOCATION AND No. OF BOREHOLE. 133-2-1
- SOIL TYPES INDICATED IN THE BOREHOLES ARE BASED ON VISUAL CLASSIFICATION.
- FOR THE COMPLETE AS WELL AS ADDITIONAL LOG REFER TO SHEET G-7.

說明

鑽孔之位置及編號

鑽孔之土壤分類係根據現場分類及試驗結果

本圖內未顯示之詳細鑽孔請見詳圖 G-7

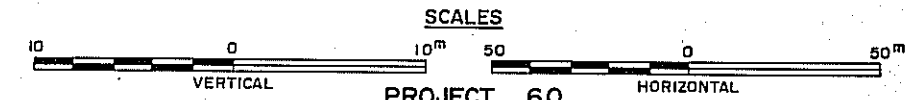

修正 REVISIONS		項目 ITEM	日期 DATE
修正	REVISIONS		

交通部台灣區高速公路工程局
TAIWAN AREA FREEWAY CONSTRUCTION BUREAU
中華民國
REPUBLIC OF CHINA

南北高速公路 NORTH-SOUTH FREEWAY
苗栗台中段 MIAOLI-TAICHUNG SECTION

開挖區土壤 斷面及平面 PLAN & SOIL SECTION
IN OPEN-CUT AREA

中華顧問工程司 CHINA ENGINEERING CONSULTANTS, INC.
日期 DATE AUG. 74 比例 SCALE AS SHOWN 圖號 SHEET G-10

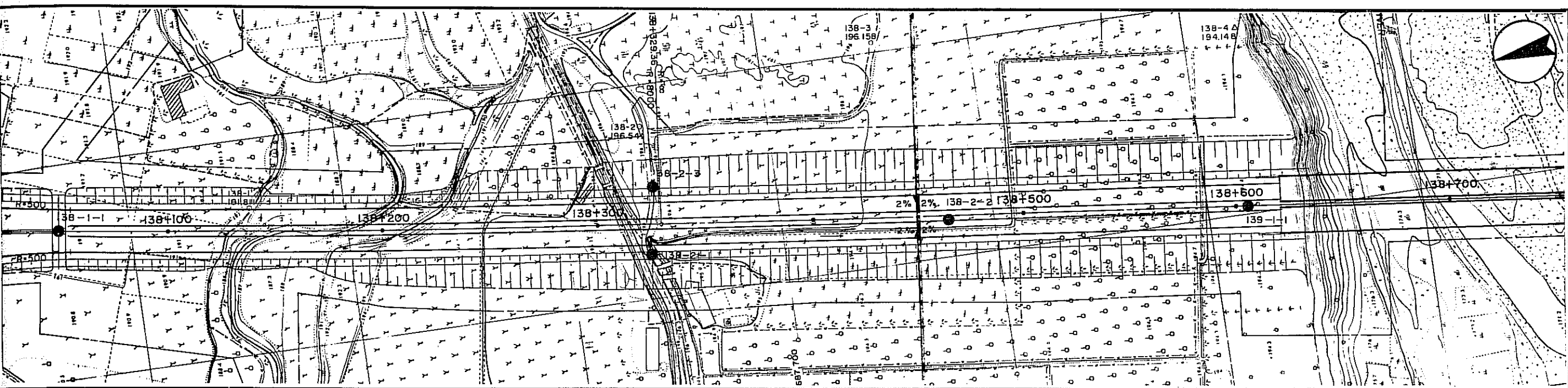

平面圖
PLAN

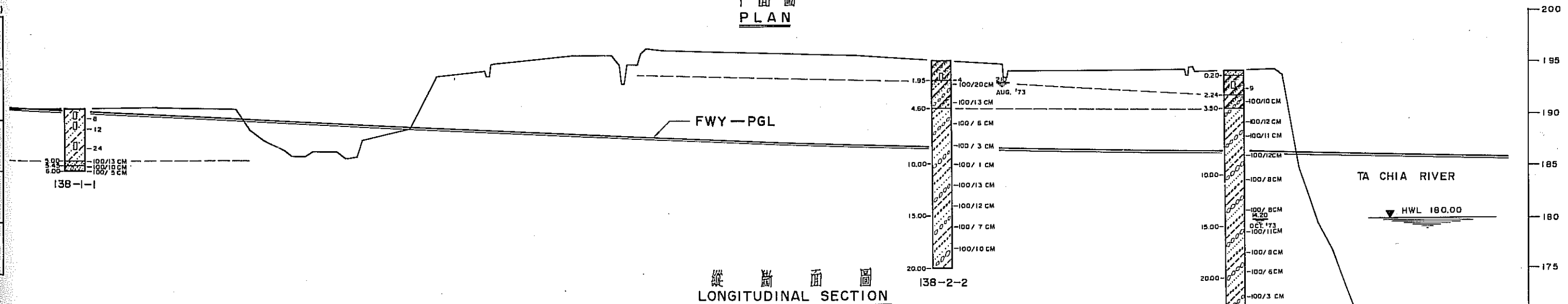

縱斷面圖
LONGITUDINAL SECTION

LEGEND: 圖例

- SILTY SAND - SANDY SILT. 沉泥質砂 砂質沉泥
- SILTY SAND CLAY - SANDY CLAY SILT. - CLAYEY SILT SAND. 沉泥質砂粘土 砂質粘土沉泥 粘土質沉泥砂
- SILTY SAND CLAY GRAVEL COBBLE BOULDER. 沉泥質砂粘土 礫石卵石
- SILTY SANDY GRAVEL COBBLE BOULDER. 沉泥質砂質 礫石卵石

BORELOG 鑽孔

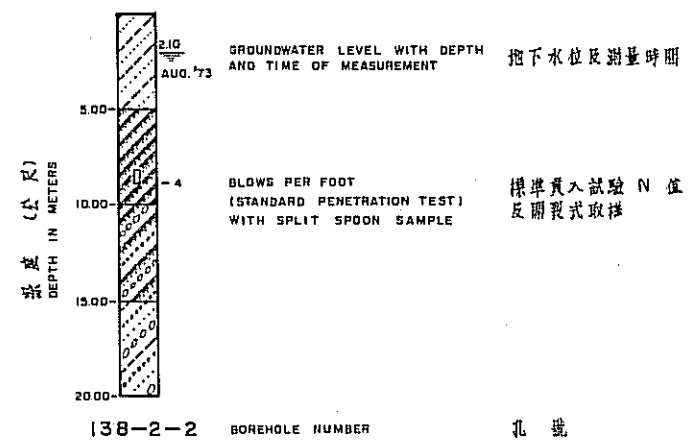

NOTE

1. LOCATION AND NO. OF BOREHOLE. 鑽孔之位置及編號
2. SOIL TYPES INDICATED IN THE BOREHOLES ARE BASED ON VISUAL CLASSIFICATION. 鑽孔之土質分類係根據現場分類及試驗結果
3. FOR THE COMPLETE AS WELL AS ADDITIONAL LOG REFER TO SHEET G-9. 本圖內未顯示之詳細鑽孔請見詳圖 G-9

說明

鑽孔之位置及編號
鑽孔之土質分類係根據現場分類及試驗結果
本圖內未顯示之詳細鑽孔請見詳圖 G-9

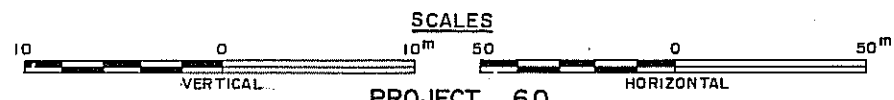

PROJECT 60

修正 項目	REVISIONS ITEM	日期 DATE

交通部台灣區高速公路工程局
TAIWAN AREA FREEWAY CONSTRUCTION BUREAU
中華民國
REPUBLIC OF CHINA
南北高速公路 NORTH-SOUTH FREEWAY
苗栗台中段 MIAOLI-TAICHUNG SECTION
開挖區土壤 PLAN & SOIL SECTION
斷面及平面 IN OPEN-CUT AREA
中華顧問工程司 CHINA ENGINEERING CONSULTANTS, INC.
日期 DATE AUG. '74 比例 SCALE AS SHOWN 圖號 SHEET G-11

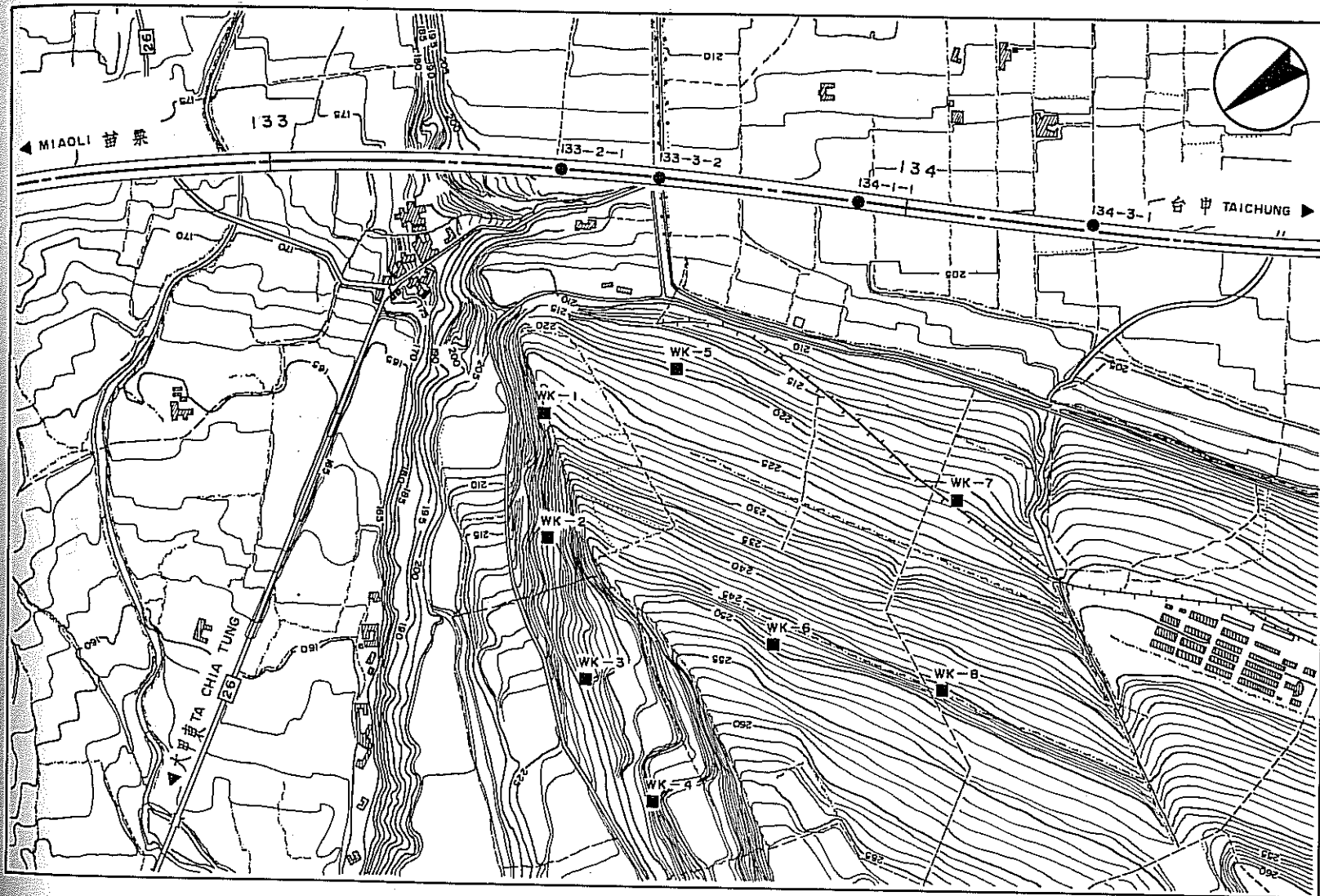

平面圖
PLAN
SCALE 1:5000

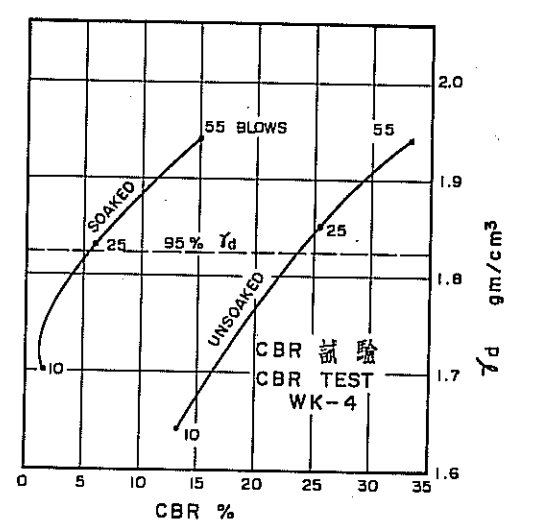
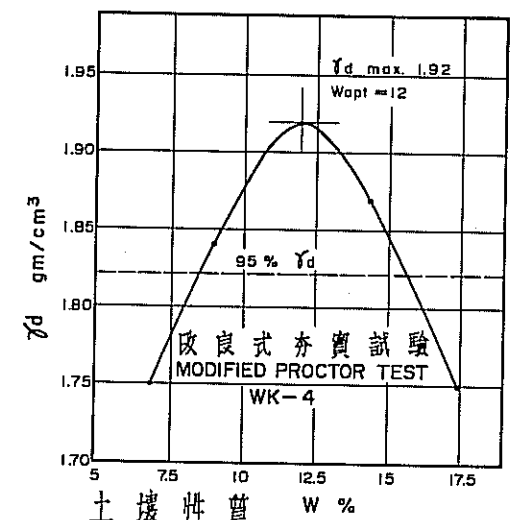
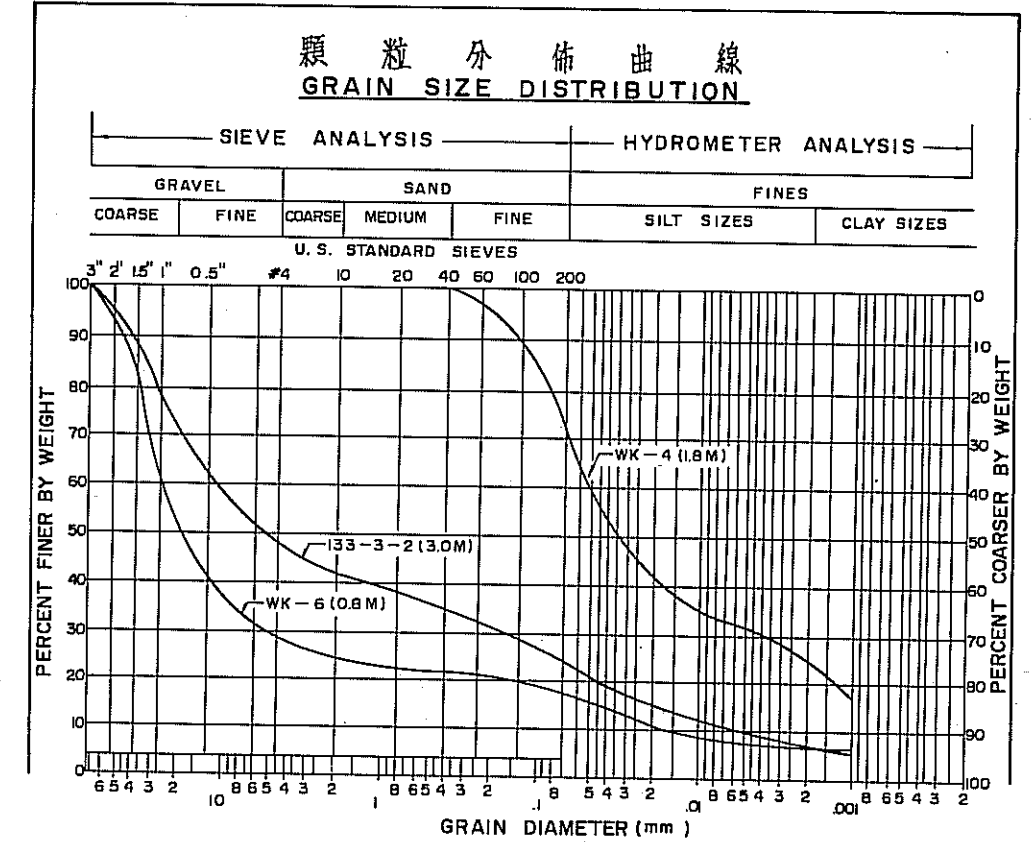
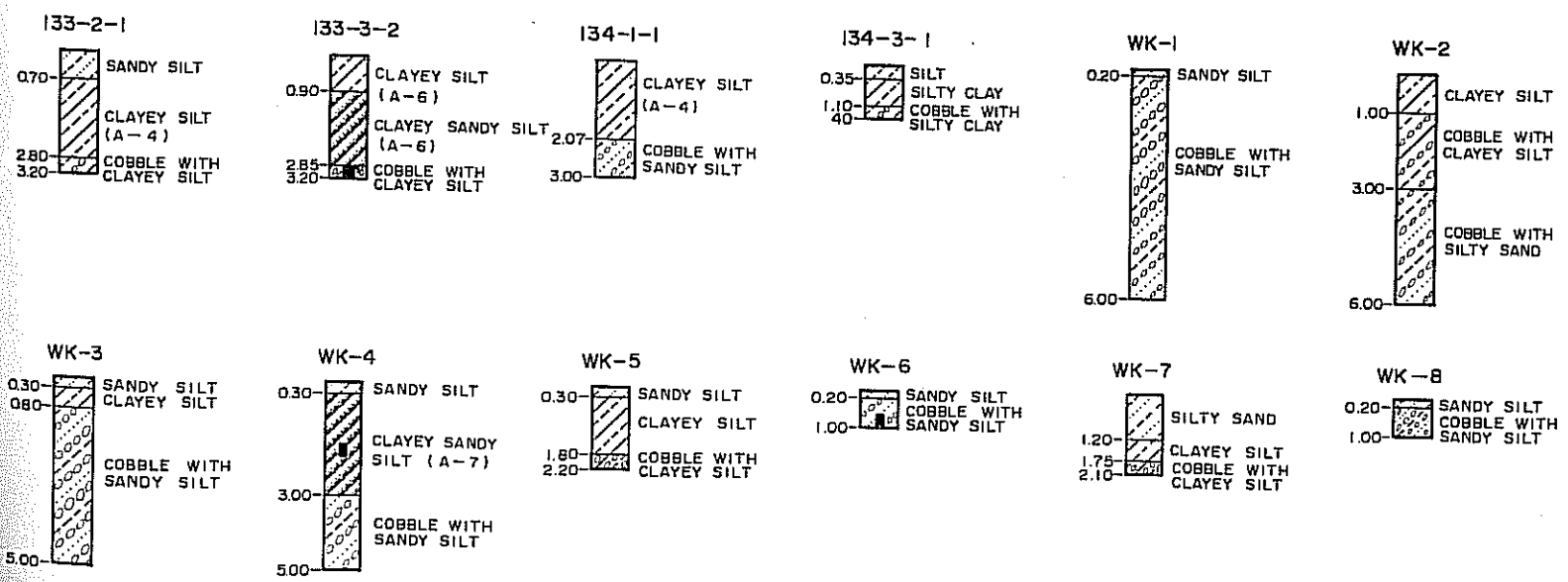

土壤性質 PROPERTIES

	133-3-2	WK-4	WK-6
IN SITU DENSITY γ_m gm/cm ³	1.99	1.72	2.05
MOD. PROCTOR DENSITY γ_d max. gm/cm ³	2.01	1.92	2.15
OPT. MOISTURE CONTENT Wopt %	9.30	11.80	6.20
LIQUID LIMIT %	37.40	40.90	40.50
PLASTICITY INDEX	15.40	16.80	15.70
CBR AT Wopt %	33.00	33.00	35.00
CBR SOAKED %	11.00	15.00	25.00

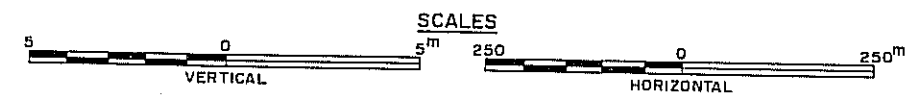

修正 項目	REVISIONS ITEM	日期 DATE

交通部台灣區高速公路工程局
TAIWAN AREA FREEWAY CONSTRUCTION BUREAU
中華民國
南北高速公路 NORTH-SOUTH FREEWAY
苗栗台中段 MIAOLI-TAICHUNG SECTION
土壤剖面及性質 借土區 ⑤
SOIL SECTION & PROPERTIES BORROW AREA ⑤
中華顧問工程司
CHINA ENGINEERING CONSULTANTS, INC.
日期 DATE AUG. '74 比例 SCALE AS SHOWN 圖號 SHEET G-12

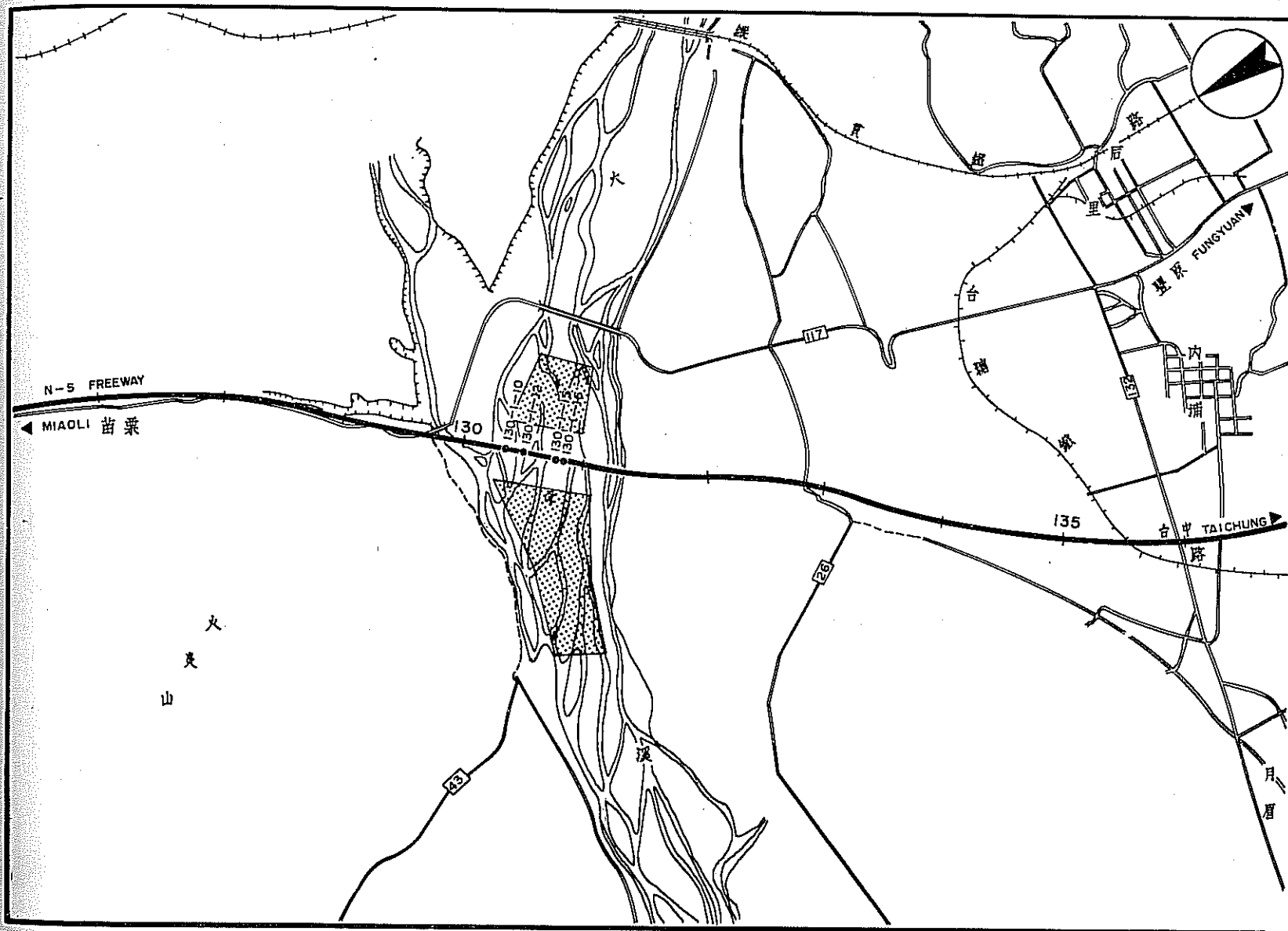

平面圖
PLAN



代表性土壤斷面
TYPICAL SOIL PROFILE

顆粒分佈曲線
GRAIN SIZE DISTRIBUTION

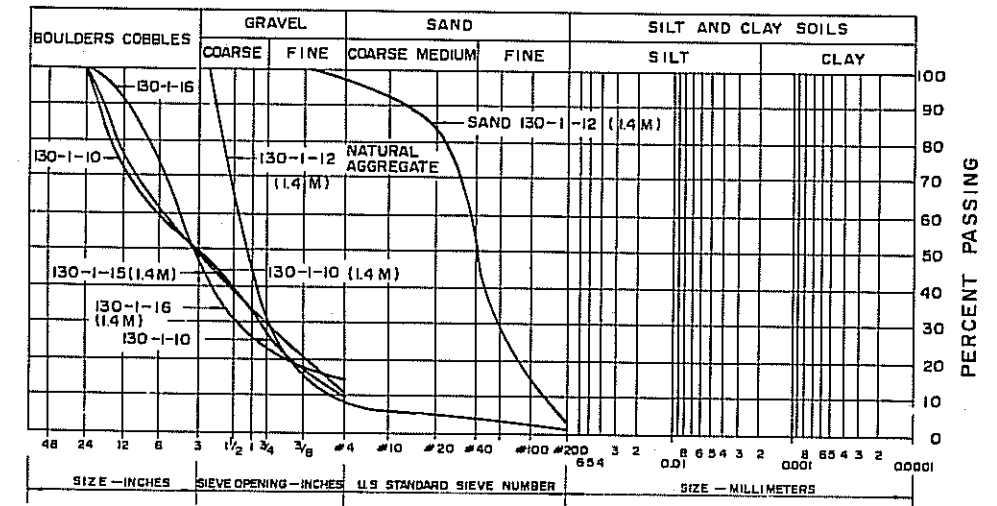

天然級配砂石料性質
PROPERTIES OF NATURAL AGGREGATE AND SAND

	AGGREGATE	SAND
SAND EQUIVALENT	65	73
LOS ANGELES ABRASION	17	
R-VALUE	63	
PERCENT OF FINE	2	
F. M.		1.92
SOUNDNESS		6.5%

預估數量
ESTIMATED QUANTITY

APPROXIMATE LENGTH	L = 2000 M
AVERAGE WIDTH	W = 400 M
AVERAGE DEPTH	D = 2.0 M
Q = 2000 M X 400 M X 2 M = 1,600,000 M ³	

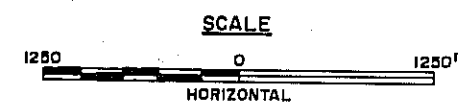

PROJECT 60

修正 項目	REVISIONS ITEM	日期 DATE

交通部台灣區高速公路工程局
TAIWAN AREA FREEWAY CONSTRUCTION BUREAU
中華民國
南北高速公路
MIAOLI-TAICHUNG SECTION
大安溪砂石場
及借土區④
QUARRY SITE, BORROW AREA
④ AT TA AN RIVER
中華顧問工程司
CHINA ENGINEERING CONSULTANTS, INC.
日期 DATE AUG. '74 比例 SCALE AS SHOWN 圖號 SHEET G-13

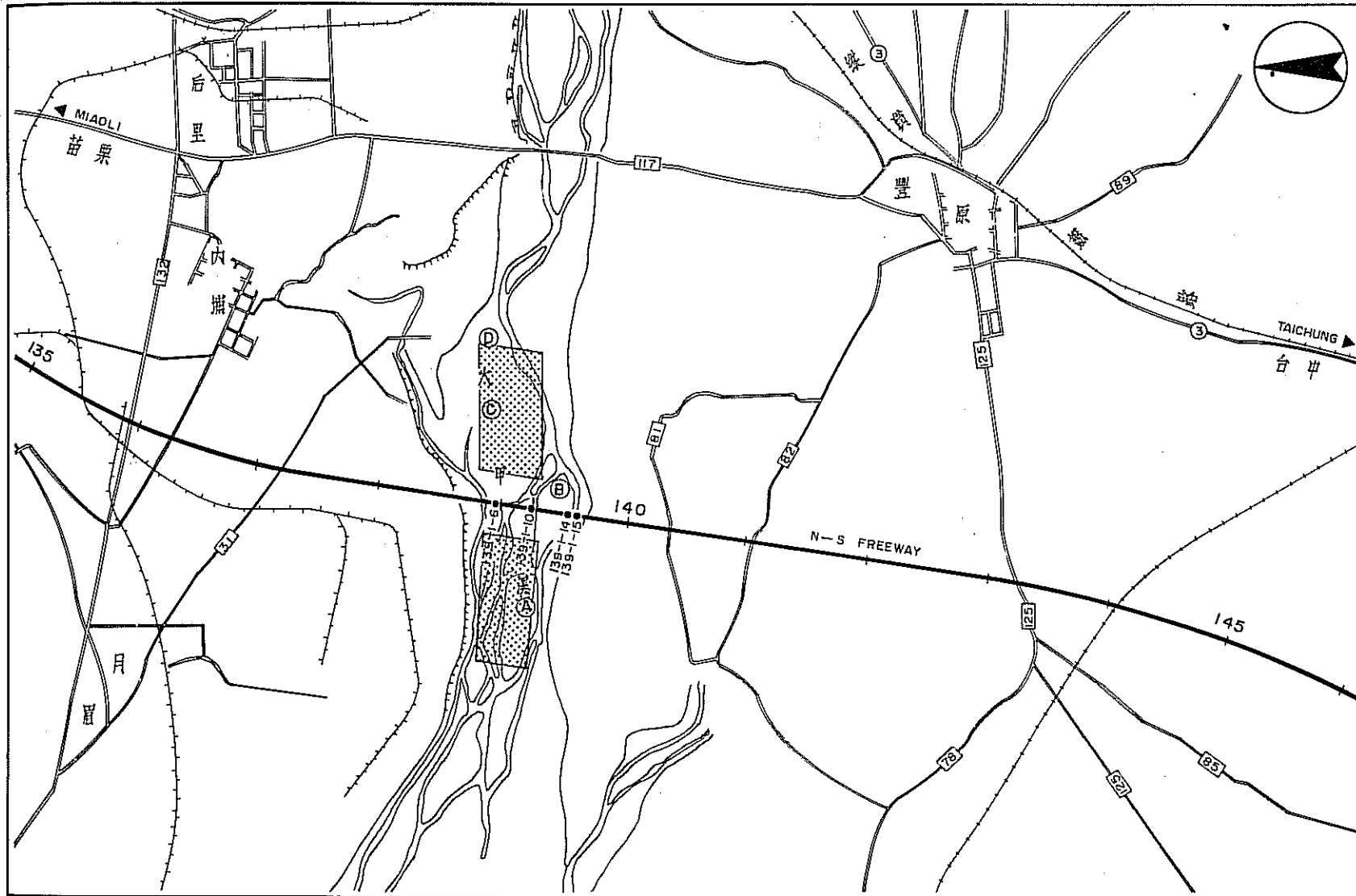

平面圖
PLAN

代表性土壤斷面
TYPICAL SOIL PROFILE

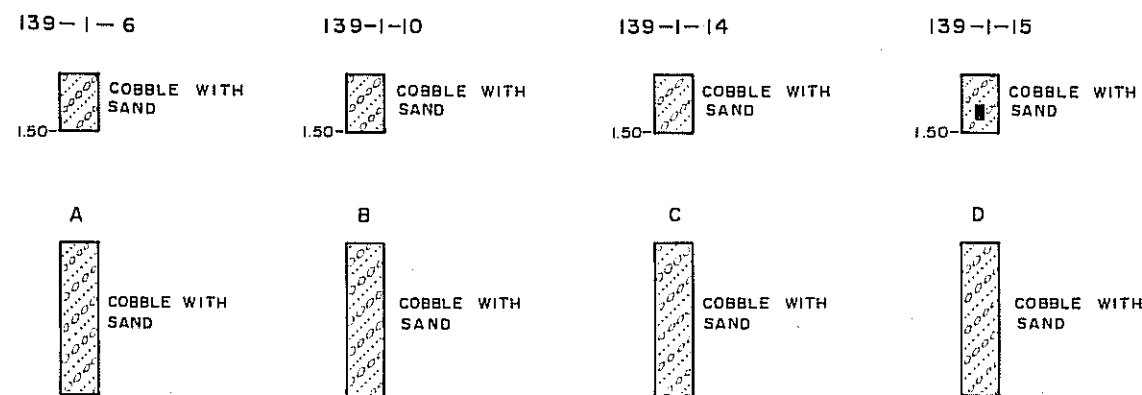

顆粒分佈曲線
GRAIN SIZE DISTRIBUTION

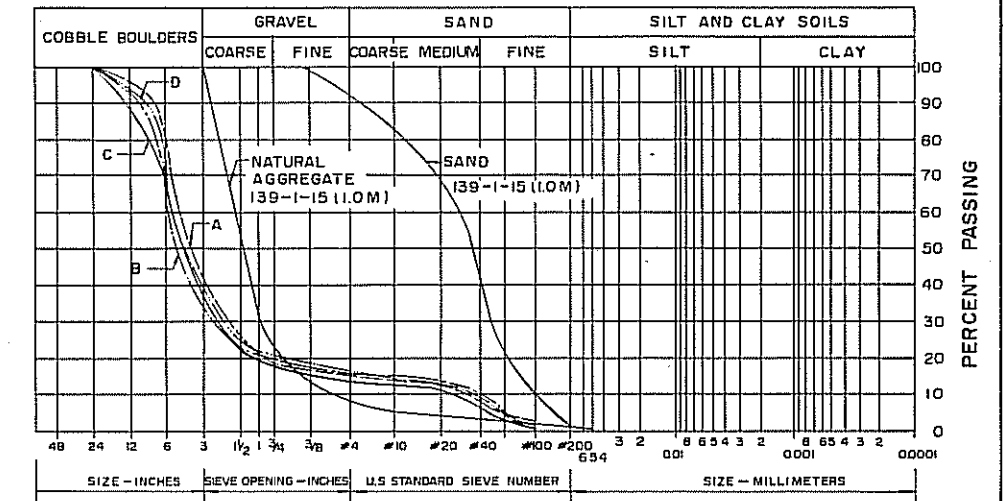

天然級配砂石料性質
PROPERTIES OF NATURAL AGGREGATE AND SAND

	AGGREGATE	SAND
SAND EQUIVALENT	88	76
LOS ANGELES ABRASION	16	
R-VALUE	72	
PERCENT OF FINE	2	
F. M.		2.53
SOUNDNESS		4.3

預估數量
ESTIMATED QUANTITY

APPROXIMATE LENGTH. L = 2,000 M
 AVERAGE WIDTH W = 350 M
 AVERAGE DEPTH D = 2.0 M
 $Q = 2,000^M \times 350^M \times 2.0^M = 1,400,000 M^3$

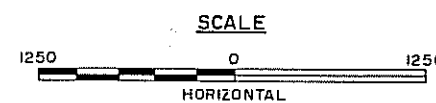

PROJECT 60

修正 REVISIONS	項目 ITEM	日期 DATE

交通部台灣區高速公路工程局
TAIWAN AREA FREEWAY CONSTRUCTION BUREAU
中華民國 REPUBLIC OF CHINA
南北高速公路 NORTH-SOUTH FREEWAY
苗栗台中段 MIAOLI-TAICHUNG SECTION
大甲溪砂石場 QUARRY SITE, BORROW AREA
反借土區 ⑥ AT TA CHIA RIVER
中華顧問工程司 CHINA ENGINEERING CONSULTANTS, INC.
日期 DATE AUG. '74 比例 SCALE AS SHOWN 圖號 SHEET G-14

高速公路縱斷面
REALIZED FREEWAY PROFILE

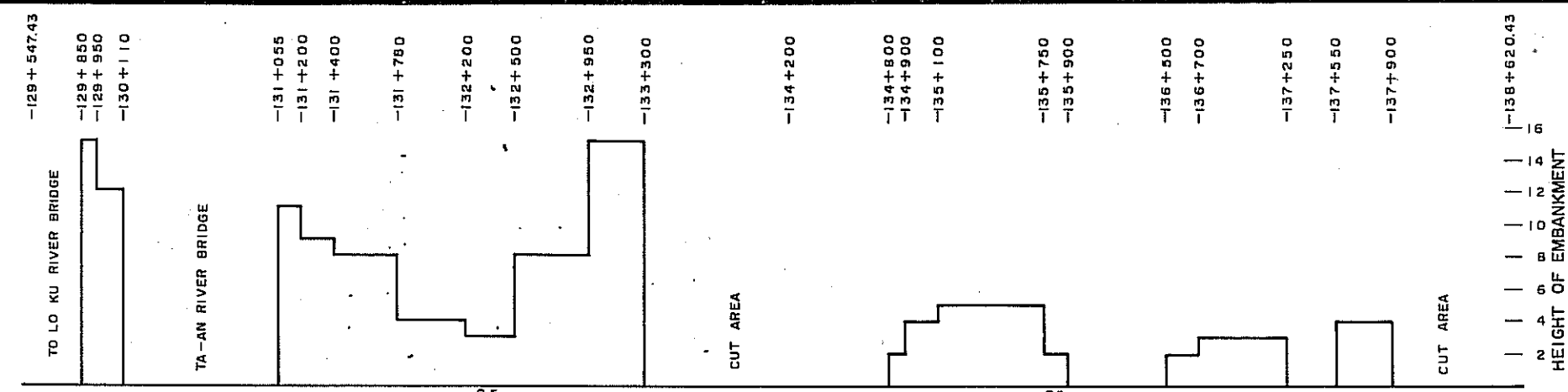

估計沉陷量 (公分)
ESTIMATED SETTLEMENTS
IN CENTIMETERS

坡趾處
AT THE TOE _____

路肩處
AT THE SHOULDER _____

中心線處
UNDER THE CENTERLINE _____

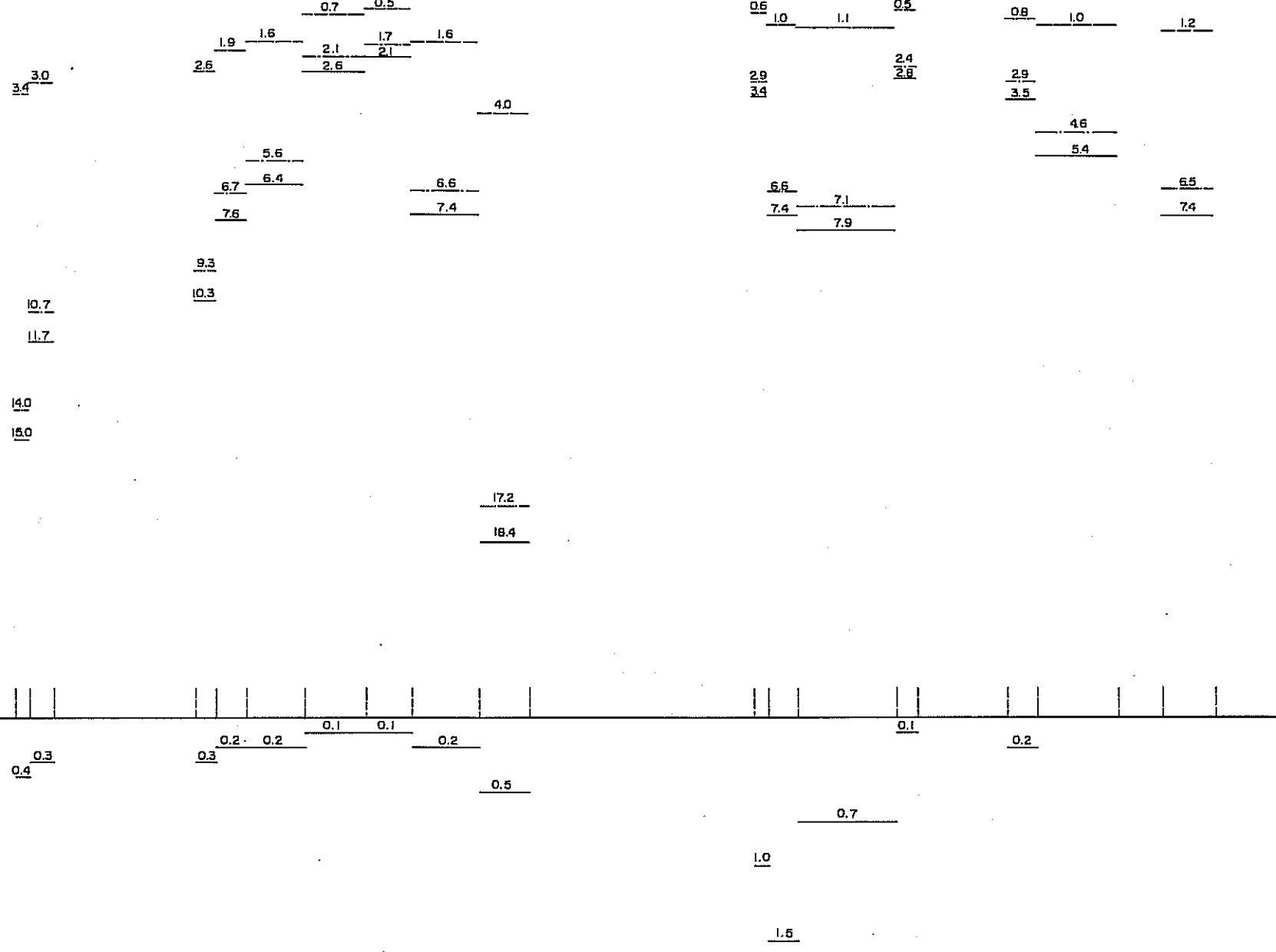

壓密 90% 所需時間 (月)
TIME OF 90% CONSOLIDATION
IN MONTH

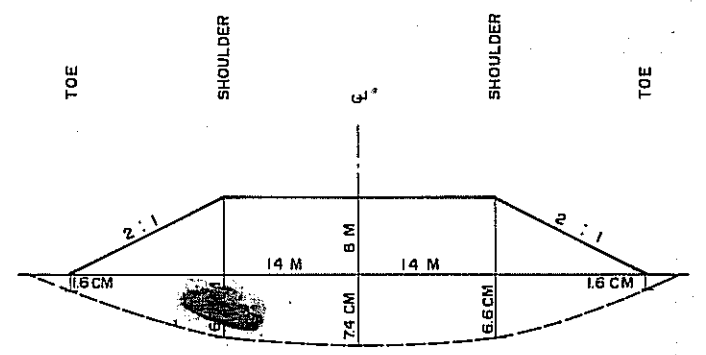

平原區
FLAT TERRAIN

估計沉陷斷面
SETTLEMENT CRATER

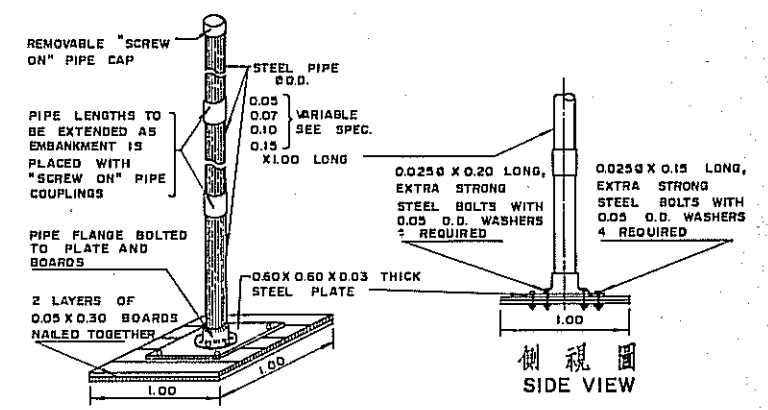

土方沉陷測量板
EARTHWORK SETTLEMENT PLATFORM

修正 REVISIONS		PROJECT 60	
項目 ITEM	日期 DATE	交通部台灣區高速公路工程局 TAIWAN AREA FREEWAY CONSTRUCTION BUREAU 中華民國 REPUBLIC OF CHINA	
		南北高速公路 苗栗台中段 NORTH-SOUTH FREEWAY MIAOLI-TAICHUNG SECTION	
		沉陷分析 SETTLEMENT ANALYSIS	
		中華顧問工程司 CHINA ENGINEERING CONSULTANTS, INC.	
		日期 DATE AUG '74 比例 SCALE AS SHOWN 圖號 SHEET G-21	

箱 涵 估 計 沉 陷 表
ESTIMATED SETTLEMENT UNDER THE CENTER OF BOXES BY THE ADJACENT EMBANKMENT

(一) DRAINAGE BOXES

BOXES < 2.5 M ARE NOT INCLUDED

PROJECT NO.	STATION	WIDTH/HEIGHT	LENGTH	SETTLEMENT (cm) UNDER THE CENTER
55	108+600	2 X 2.5/2.5	46.8	1
	109+126	2 X 3.5/2.5	34.7	2
56	110+490	3 X 3.5/3.0	63.1	8
55	116+812	1 X 2.5/2.0	51.3	7
57	117+415	2 X 5.0/3.5	44.7	11
	121+520	2 X 2.0/2.0	37.7	6
58	126+330	2 X 2.5/2.5	39.0	3
	127+055	1 X 2.5/2.0	44.7	3
	127+382	1 X 2.5/2.5	39.6	3
	127+886	2 X 2.5/2.5	34.6	4
	128+255	1 X 3.0/2.0	71.0	2
	128+600	1 X 3.0/2.0	69.7	1
	129+143	1 X 3.0/2.0	62.8	4
59	129+474	1 X 3.0/2.0	77.2	11
	130+002	2 X 3.5/3.0	72.0	15
60	132+203	1 X 4.0/3.0	33.5	3
	132+555	1 X 3.5/3.0	32.7	4
	132+997	3 X 5.0/3.0	68.5	14
	134+490	2 X 2.0/1.7	46.4	5
	135+286	2 X 2.0/2.0	46.6	7
	136+789	1 X 2.5/2.0	35.3	3
	137+000	3 X 4.0/3.0	35.1	5
61	137+677	1 X 2.5/2.0	98.0	8
	138+050	2 X 3.0/2.5	33.1	6
62	139+785	2 X 3.0/3.0	55.0	8
	140+594	3 X 3.0/3.0	40.8	3
	140+711	3 X 3.0/3.0	39.2	5
	140+985	2 X 3.0/3.0	37.4	4
	142+043	3 X 3.5/3.0	39.6	3
	142+315	2 X 2.0/1.7	42.8	6
	142+355	1 X 4.0/4.0	63.2	9
	142+785	2 X 4.0/3.5	69.7	13
	143+200	3 X 3.0/3.0	66.6	9
	143+820	2 X 3.0/3.0	53.9	11
63	144+620	2 X 3.5/3.0	54.7	14
	145+760	2 X 3.0/3.0	49.9	10
	147+144	2 X 3.0/2.5	34.8	8
63	149+640	3 X 4.0/3.0	142.6	12

(二) FIELD PATH OR 1-LANE U/C BOXES

PROJECT NO.	STATION	WIDTH/HEIGHT	LENGTH	SETTLEMENT (cm) UNDER THE CENTER
55	109+172	1 X 3.0/2.5	30.2	2
	110+232	1 X 3.0/3.0	31.7	3
	112+398	1 X 3.0/3.0	45.0	9
	113+532	1 X 3.0/2.5	31.4	3
	114+056	1 X 3.0/2.5	31.0	3
	114+776	1 X 7.0/4.6	32.3	4
	115+846	1 X 3.0/3.0	34.4	8
	116+464	1 X 3.0/3.0	30.3	10
	117+187	1 X 3.0/3.0	40.1	9
	57	121+575	1 X 3.0/2.5	33.7
58	122+885	1 X 3.0/3.0	32.0	4
	123+775	1 X 3.0/2.5	30.0	2
	126+425	1 X 3.0/2.5	33.4	4
59	127+307	1 X 3.0/2.5	32.0	5
	131+415	1 X 3.0/3.0	41.5	3
60	131+794	1 X 3.0/3.0	31.2	2
	135+449	1 X 5.5/3.5	41.5	4
61	136+844	1 X 3.0/2.0	29.4	3
	140+050	1 X 3.0/3.0	30.8	5
62	141+755	1 X 7.0/4.3	33.4	5
	142+410	1 X 3.0/3.0	32.9	4
	143+840	1 X 3.0/3.0	38.3	8
	144+074	1 X 7.0/4.8	40.5	7
	144+384	1 X 3.0/3.0	39.1	10
	144+954	1 X 3.0/3.0	32.5	4
	145+900	1 X 3.6/3.5	30.6	4
	146+265	1 X 3.6/3.5	30.0	4
63	146+700	1 X 3.0/2.5	30.4	4
	148+930	1 X 3.0/2.5	38.6	4
	150+229	1 X 5.5/3.5	31.0	5
	150+572	1 X 3.0/3.0	30.8	5
	152+351	1 X 7.0/4.8	32.7	6
	153+321	1 X 7.0/4.3	50.9	10
	154+068	1 X 7.0/4.3	45.9	7

NOTE:

THE SETTLEMENT UNDER BOTH END OF BOX CAN BE ESTIMATED BY RATIONAL FORMULA $s_e = s_c \times R$

WHERE

s_c = SETTLEMENT (CM) UNDER THE CENTER OF BOX.

R = $1 - 0.04 h$ (M)

h = THE COVER HEIGHT OVER THE TOP OF BOX.

修正 REVISIONS	項目 ITEM	日期 DATE

PROJECT 60

交通部台灣區高速公路工程局
TAIWAN AREA FREEWAY CONSTRUCTION BUREAU
中華民國
REPUBLIC OF CHINA
南北高速公路
NORTH-SOUTH FREEWAY
苗栗台中段
MIAOLI-TAICHUNG SECTION

箱涵沉陷表
TABLES OF
BOX SETTLEMENT

中華顧問工程司
CHINA ENGINEERING CONSULTANTS, INC.
日期 DATE AUG. 174 比例 SCALE NONE 圖號 SHEET G-22

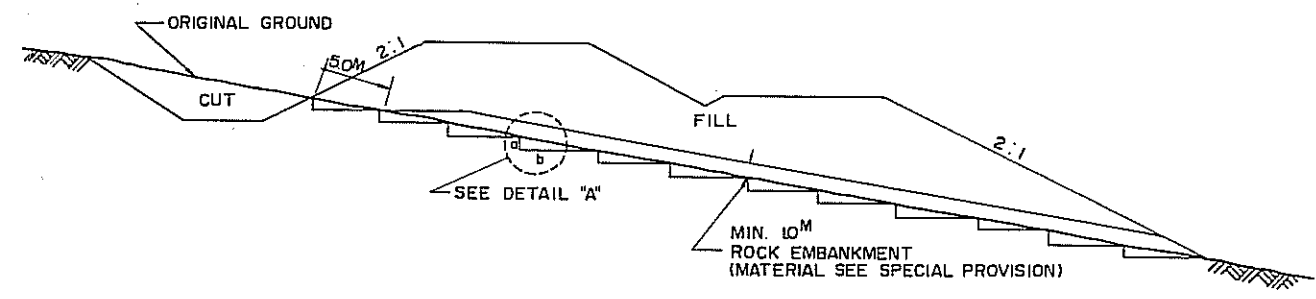

斜坡路堤斷面
EMBANKMENT ON SLOPED GROUND
SCALE 1:300

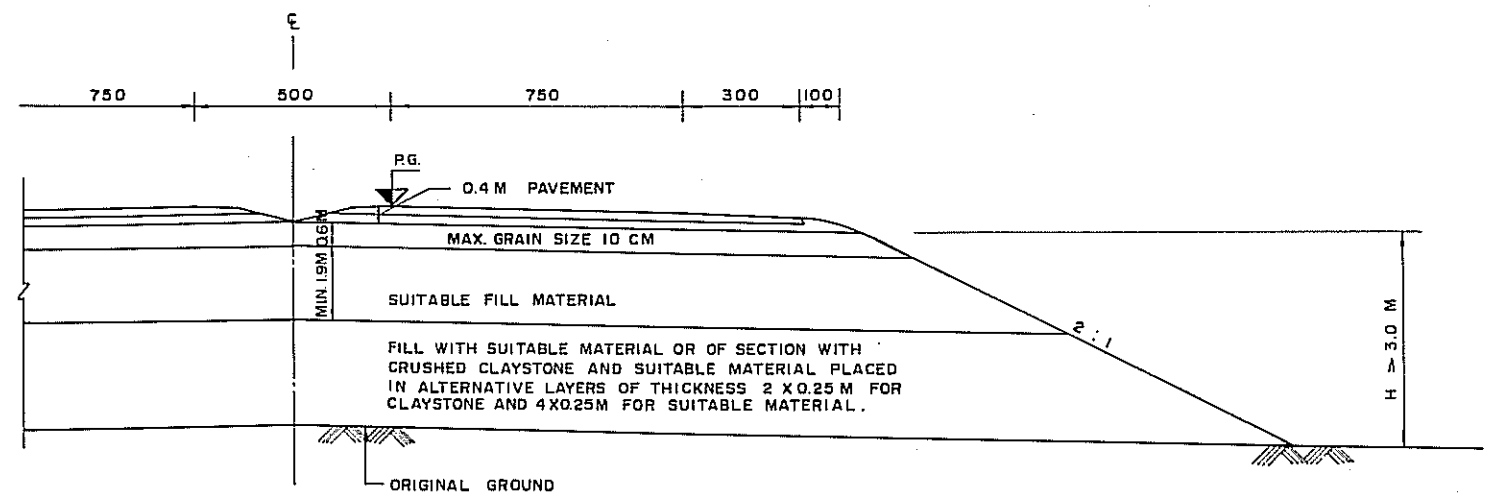

路堤斷面
EMBANKMENT SECTION
SCALE 1:100
(FOR PROJECT 55, 56 ONLY)

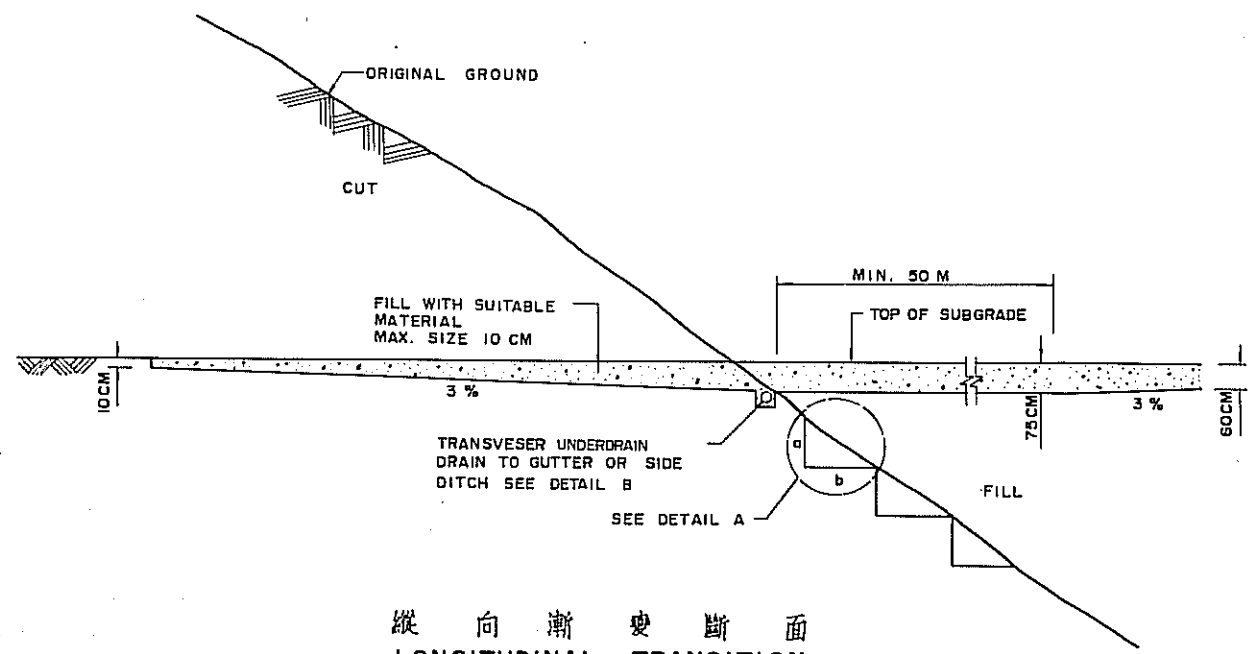

縱向漸變斷面
LONGITUDINAL TRANSITION
SCALE 1:100

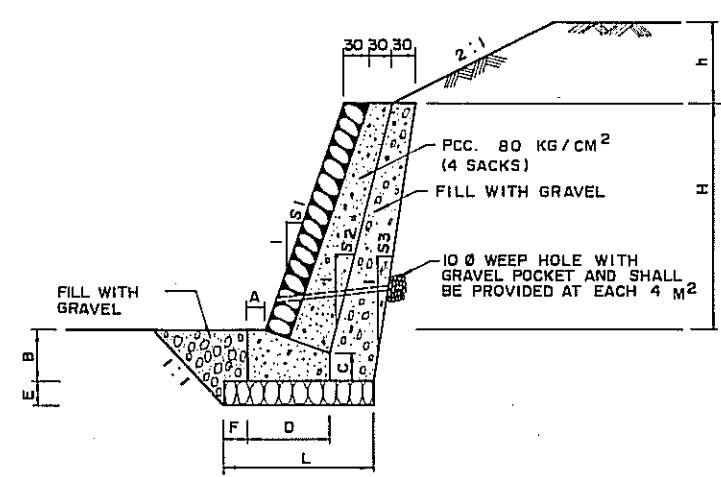

標準斷面
TYPICAL SECTION
SCALE 1:50

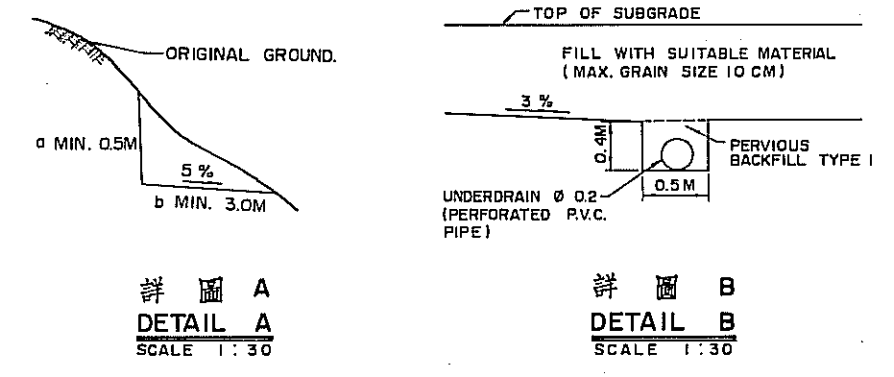

詳圖 A
DETAIL A
SCALE 1:30

詳圖 B
DETAIL B
SCALE 1:30

說明：

1. 鄰近路堤之路塹區設計高程下之不適宜材料，應用適用材料置換之。
2. 三明治式擋土牆之基礎，應築於底部與土之摩擦係數 (f) 大於 0.55 之拋層上。
3. 三明治式擋土牆，限使用於跨越道路。

NOTE :

1. THE UNSUITABLE MATERIAL BELOW THE SUBGRADE BETWEEN CUT & FILL SECTION SHALL BE REPLACED WITH SUITABLE MATERIAL AS SPECIFIED.
2. THE FOUNDATION OF SANDWICH RETAINING WALL SHALL BE BUILT ON LAYER, OF WHICH THE FRICTION FACTOR (f) BETWEEN SOIL AND BASE SHALL BE LARGER THAN 0.55.
3. SANDWICH RETAINING WALL USED FOR OVERCROSSING ROADWAY ONLY.

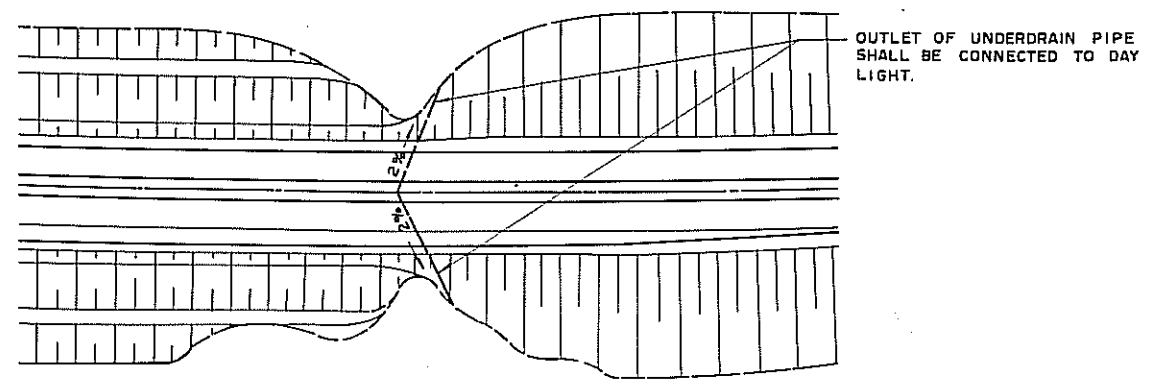

填挖交接處
JOINT BETWEEN CUT & FILL SECTION
SCALE 1:1000

H (m)	h (m)	S1	S2	S3	A (cm)	B (cm)	C (cm)	D (cm)	E (cm)	F (cm)	L (cm)
2	6	0.30	0.25	0.20	10	35	15	80	20	15	140
3	5	0.30	0.25	0.20	10	38	15	84	20	15	150
5	0	0.30	0.25	0.25	10	43	20	85	20	20	130
6	0	0.30	0.25	0.20	10	52	25	95	20	20	170

三明治式擋土牆
SANDWICH RETAINING WALL

SOIL STANDARD DETAILS

修正	REVISIONS	項目	ITEM	日期	DATE

交通部台灣區高速公路工程局
TAIWAN AREA FREEWAY CONSTRUCTION BUREAU
中華民國
REPUBLIC OF CHINA
南北高速公路
NORTH-SOUTH FREEWAY
苗栗台中段
MIAOLI-TAICHUNG SECTION
路堤及其他
EMBANKMENT & MISCEL.
詳圖
DETAILS
中華顧問工程司
CHINA ENGINEERING CONSULTANTS, INC.
日期 DATE AUG. '74 比例 SCALE AS SHOWN 圖號 SHEET GT - 2

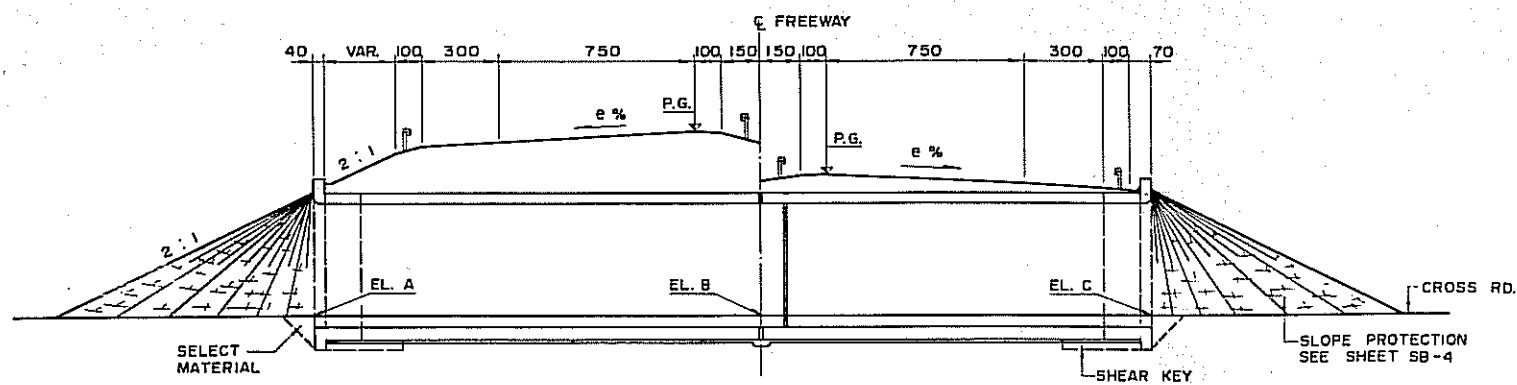

標準縱斷面圖 A-A
TYPICAL LONGITUDINAL SECTION A-A

SCALE 1:150

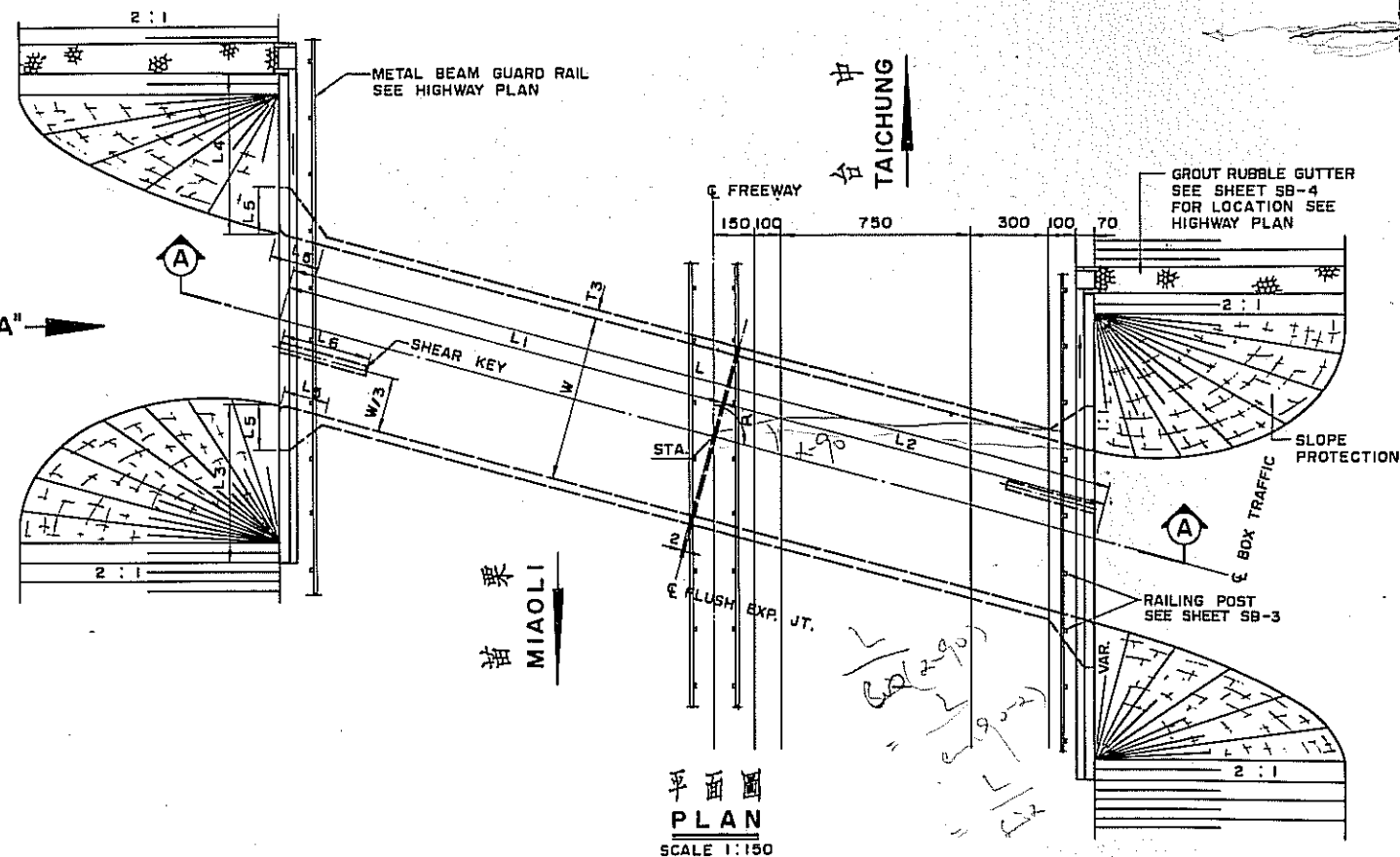

平面圖
PLAN

SCALE 1:150

說明:

1. 從說明參照圖
2. 表中所註之尺寸為結構物完成後之標高。施工中引起結構之沉陷應予考慮。沉陷資料參閱土壤圖。
3. 除另有註明者外，所有尺寸均以公分計。
4. 所有鋼筋直徑均以公厘計。
5. 穿越路之標高參照公路平面圖。
6. 伸縮縫之最大間距不得大於 21 公尺。施工縫之最大間距不得大於 10 公尺。設置位置受工程師之指示決定之。

NOTES:

1. FOR GENERAL NOTES SEE SHEET ST-1.
2. THE ELEVATIONS GIVEN IN THE LIST ARE FORMATION ELEVATION. ALL SETTLEMENTS OF THE STRUCTURE DURING CONSTRUCTION SHALL BE CONSIDERED, FOR SETTLEMENT DATA SEE SOIL PLAN.
3. ALL DIMENSIONS ARE IN CM UNLESS OTHERWISE NOTED.
4. ALL REINFORCING BAR DIAMETERS ARE IN MM.
5. ROADWAY SLOPE SEE HIGHWAY PLAN.
6. MAX. SPACING OF EXPANSION JOINT SHALL NOT OVER 21M, AND CONSTRUCTION JOINT SHALL NOT OVER 10M. THE LOCATIONS DIRECTED BY THE ENGINEER.

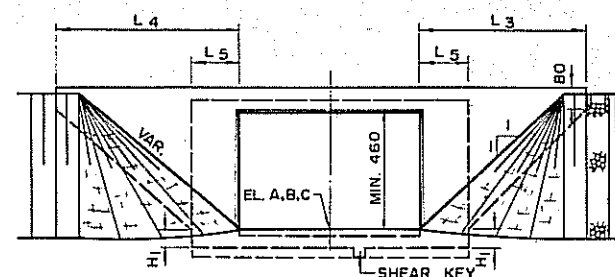

單車道箱涵
1 LANE BOX

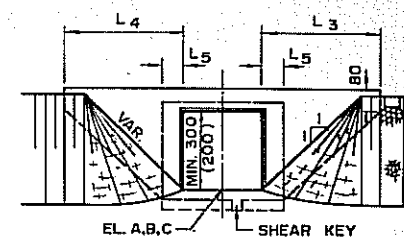

農路箱涵
FIELD PATH BOX

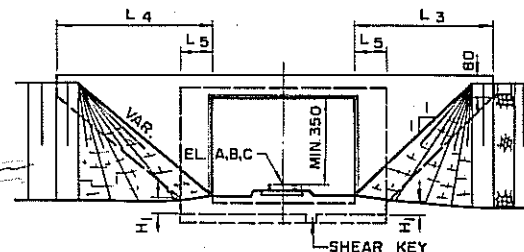

糖鐵箱涵
SUGAR REFINERY RAILROAD BOX

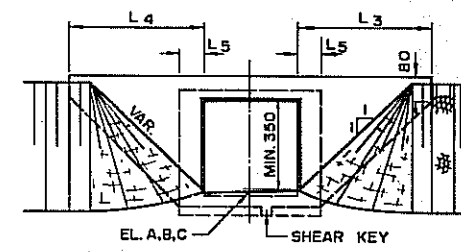

慢車道箱涵
SLOW MOVING LANE BOX

穿越箱涵表
LIST OF UNDERCROSSING BOXES

PR. NO.	BOX ITEM	STATION	CROSSING ANGLE α	SIZE OF BOX			LENGTH OF BOX					DIMENSION OF WINGWALL			LENGTH OF SHEAR KEY L ₆	FREEWAY P.G.L. EL.	ELEVATION AT ϵ BOX			REMARKS
				W	H	TYPE	L	L ₁	L ₂	L ₃	L ₄	L ₅	H ₁	TYPE			EL. A	EL. B	EL. C	
60	F.P.	131 + 79.4	82°30'00"	3.0	3.0	A	31.2	14.9	16.3	4.6	4.6	0.9			180.669	176.91	176.76	176.60		
	S.R.R.	135 + 448.587	48°05'32"	6.5	4.0	A	41.5	19.9	21.6	6.9	5.4	2.0	1.2	0.5	10.0	207.490	202.75	202.87	202.74	
	F.P.	136 + 84.4	90°00'00"	3.0	2.0	A	29.4	14.7	14.7	3.6	3.6	0.7			195.579	192.87	192.80	192.73		
	F.P.	0 + 546.00 (RAMP 1)	46°41'32.4"	3.0	3.0	B	33.8	21.6	12.2	6.0	4.6	1.2	0.9		211.656	208.36	207.50	207.01		

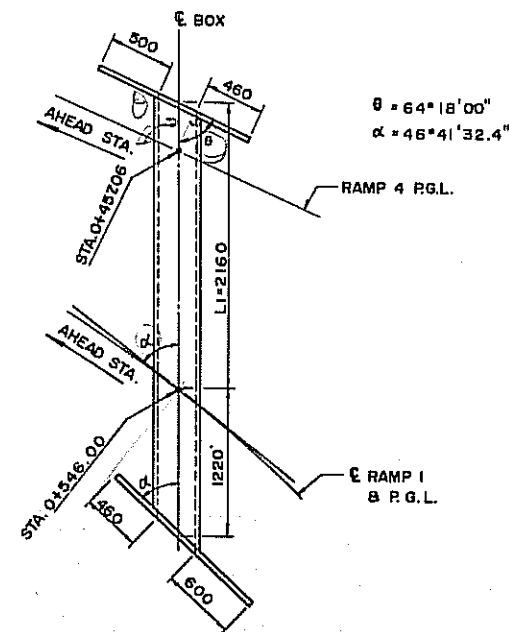

KEY PLAN FOR STA. 0 + 546.00

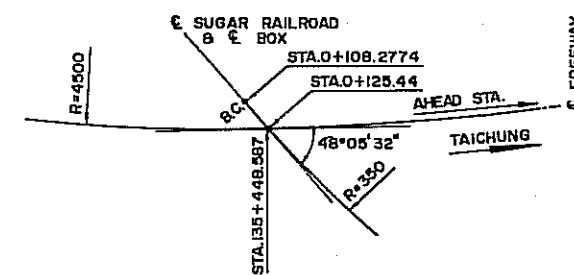

KEY PLAN FOR STA. 135 + 448.587

NOTE: FOR BOX ON CURVE PLACE MAIN REINFORCEMENT ON RADIAL DIRECTION

PROJECT 60

修正	REVISIONS	項目	ITEM	日期	DATE

交通部台灣區高速公路工程局
TAIWAN AREA FREEWAY CONSTRUCTION BUREAU
中華民國
REPUBLIC OF CHINA
南北高速公路
MIAOLI-TAICHUNG SECTION
苗栗台中段
穿越箱涵
UNDERCROSSING BOXES
總平面圖
GENERAL PLAN
中華顧問工程司
CHINA ENGINEERING CONSULTANTS, INC.
日期 DATE AUG. '74 此圖 SCALE AS SHOWN 圖號 SHEET SB-1

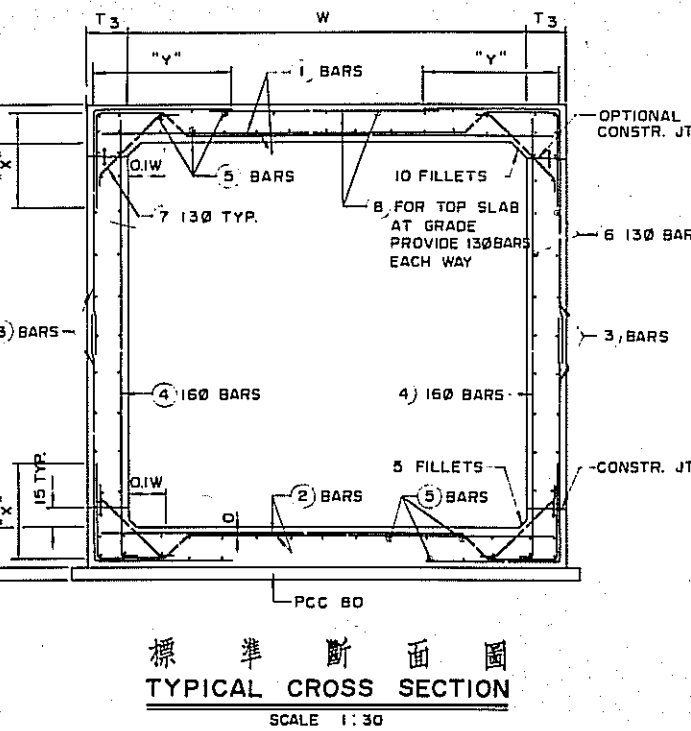

標準斷面圖
TYPICAL CROSS SECTION
SCALE 1:30

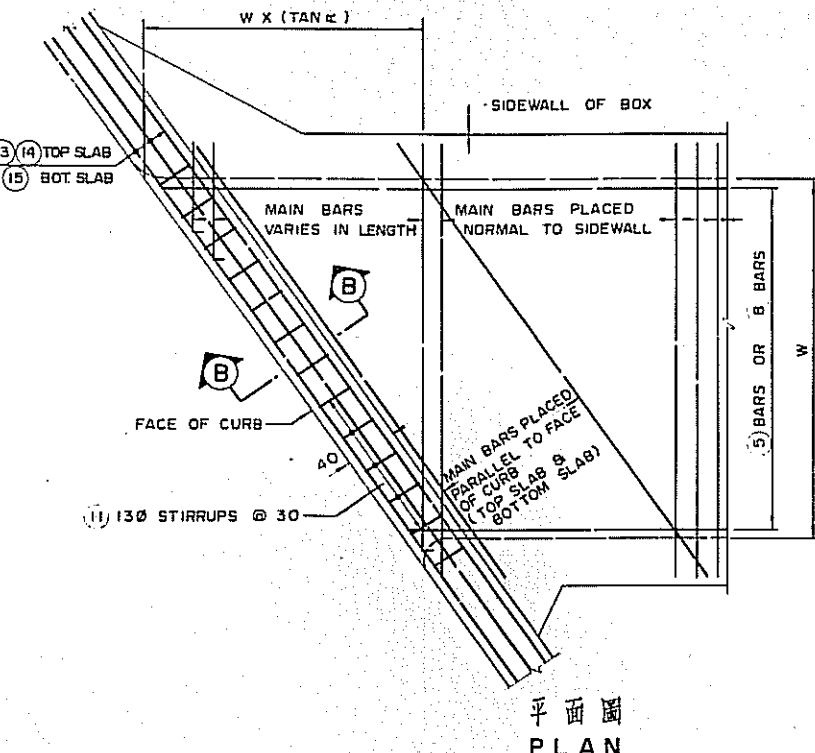

平面圖
PLAN
(CROSSING ANGLE $\alpha < 70^\circ$ OR $\alpha > 110^\circ$)

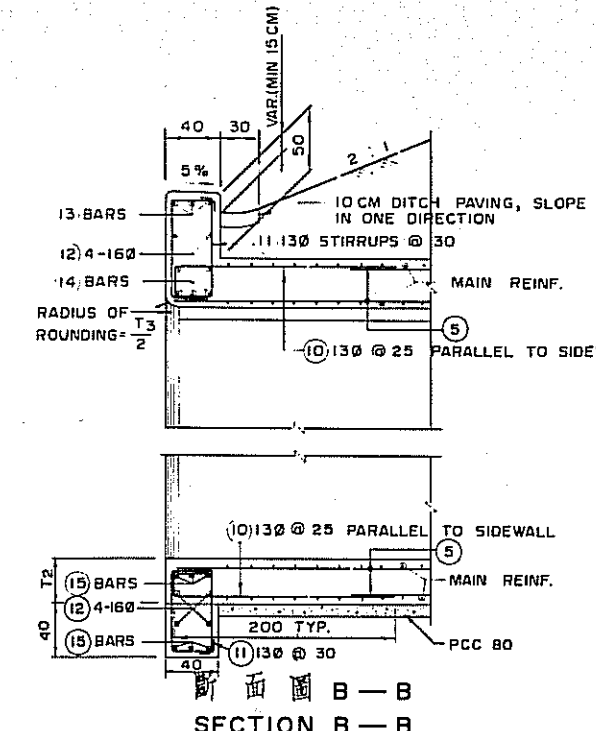

斷面圖 B-B
SECTION B-B
箱涵端部詳圖
END OF BOX DETAIL
SCALE 1:30

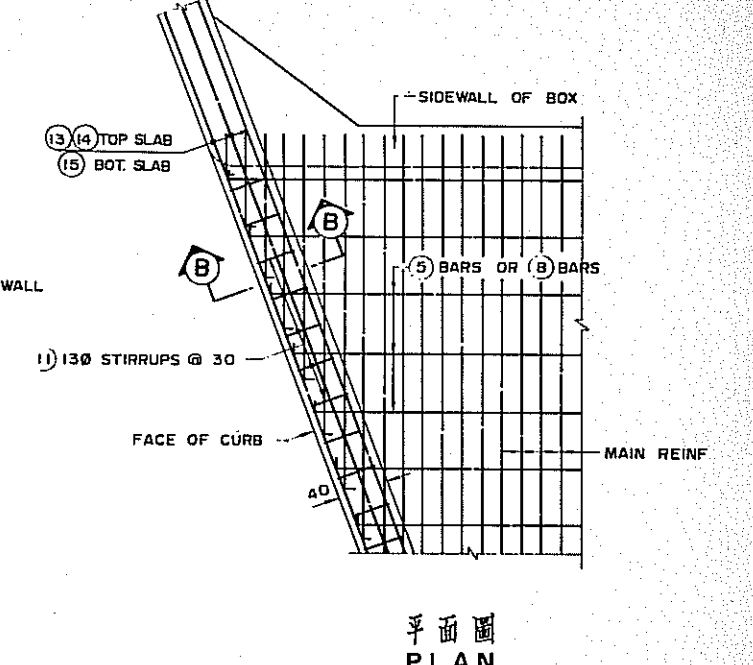

平面圖
PLAN
(CROSSING ANGLE α BETWEEN 70° TO 110°)

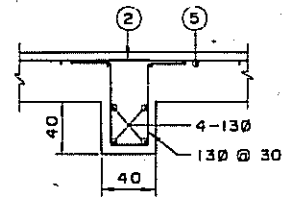

剪力樑詳圖
SHEAR KEY DETAIL
SCALE 1:30

REINFORCEMENT OF SKEW CURB			
W/SIN α (M)	~ 5.5	5.5~8.0	8.0~
(3)	3-19 ϕ	3-19 ϕ	3-25 ϕ
(4)	3-22 ϕ	3-25 ϕ	3-32 ϕ
(5)	6-22 ϕ	6-25 ϕ	6-32 ϕ
(10)	130 @ 25		
(11)	130 @ 30		
(12)	8-16 ϕ		

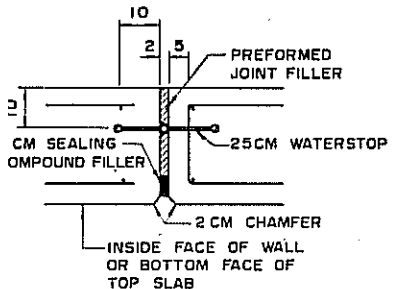

頭伸縮縫詳圖
LUSH EXP. JT. DETAIL
SCALE 1:10
(TOP SLAB & VERTICAL WALL)

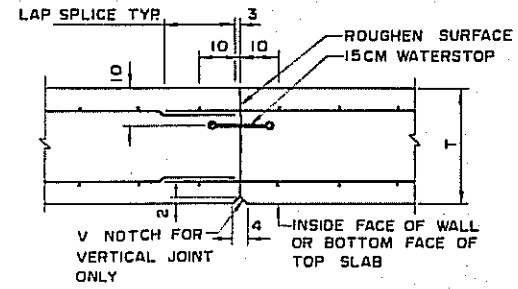

施工縫詳圖
CONSTR. JOINT DETAIL
SCALE 1:10

UNDERCROSSING BOX			FIELD PATH BOX					SLOW MOVING LANE BOX		SUGAR REFINERY RAILROAD BOX		I LANE BOX		
W	M		3.0	3.0	3.0	3.0	3.0	3.6	3.6	5.5	5.5	7.0	7.0	
H	M		2.0	2.0	3.0	3.0	3.0	3.6	3.6	4.0	4.0	4.8	4.8	
TYPE	M		A	B	A	B	C	D	E	A	B	B	C	
MAX. FILL OVER TOP	M		0.6	2.4	0.6	2.4	(4.0)	4.0	4.4	0.6	1.5	1.2	1.8	
TOP SLAB T1	CM		25	25	25	25	28	30	30	35	35	45	45	
BOTTOM SLAB T2	CM		25	25	25	25	28	32	32	35	40	50	50	
SIDEWALL T3	CM		25	25	25	25	28	28	28	35	35	40	40	
REINFORCING STEEL	①	SIZE: BAR ϕ	MM	19	19	19	19	19	22	25	25	25	29	32
		SPACING	CM	26	26	26	26	30	30	36	32	32	28	30
		DIMENSION "x"	CM	80	80	80	80	(80)	100	100	120	120	140	140
		LENGTH	M	4.26	4.26	4.26	4.26	(4.33)	5.13	5.16	7.40	7.40	9.24	9.25
		SIZE: BAR ϕ	MM	19	19	19	19	19	22	25	25	25	29	32
		SPACING	CM	26	26	26	26	30	30	36	32	32	28	30
		DIMENSION "x"	CM	80	80	80	80	80	100	100	120	120	140	140
		LENGTH	M	4.26	4.26	4.26	4.26	4.33	5.13	5.16	7.40	7.43	9.27	9.27
		SIZE: BAR ϕ	MM	16	16	16	16	16	19	19	22	22	25	29
		SPACING	CM	26	26	26	26	30	30	36	32	32	28	30
		DIMENSION "y"	CM	100	100	100	100	100	120	130	160	160	200	200
		LENGTH	M	2.43	2.43	2.93	2.93	2.96	3.51	3.66	4.25	4.28	5.28	5.38
BARS (4)	SPACING (160)	CM	26	26	26	26	30	30	36	32	32	28	30	
	SIZE: BAR ϕ	MM	13	13	13	13	13	13	16	16	16	16	16	
BARS (5)	SPACING	CM	25	25	25	25	25	20	25	30	25	20	20	
	SIZE: BAR ϕ	MM	13	13	13	13	13	13	13	13	13	13	13	
BARS (6)	SPACING	CM	30	30	30	30	30	30	30	30	30	25	25	
	SIZE: BAR ϕ	MM	13	13	13	13	13	13	13	13	13	16	16	
BARS (7)	SPACING	CM	26	26	26	26	30	30	36	32	32	28	30	
	SIZE: BAR ϕ	MM	13	13	13	13	13	13	13	13	13	16	16	
BARS (8)	SPACING	CM	39	39	39	39				32				
	SIZE: BAR ϕ	MM	13	13	13	13				13				

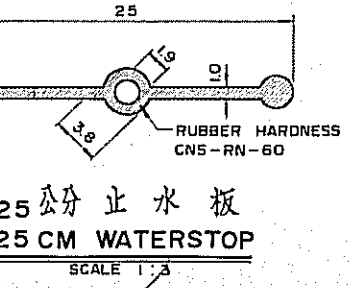

25公分止水板
25 CM WATERSTOP
SCALE 1:3

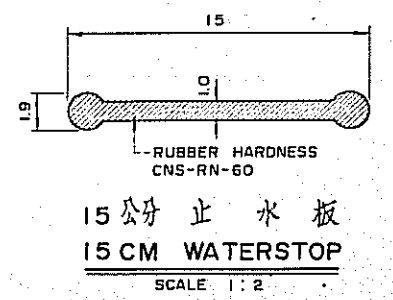

15公分止水板
15 CM WATERSTOP
SCALE 1:2

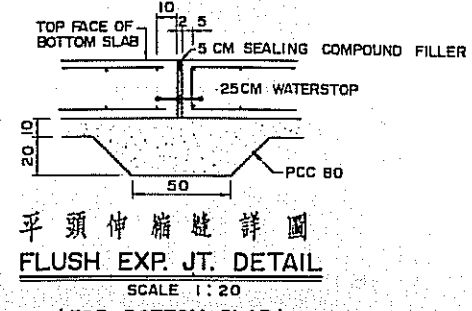

平頭伸縮縫詳圖
FLUSH EXP. JT. DETAIL
SCALE 1:20
(FOR BOTTOM SLAB)

說明:
總說明參照圖 ST-1.

NOTE:
FOR GENERAL NOTES SEE SHEET ST-1.

修正	REVISIONS	項目	日期 DATE

PROJECT 60

交通部台灣區高速公路工程局	TAIWAN AREA FREEWAY CONSTRUCTION BUREAU
中華民國	REPUBLIC OF CHINA
南北高速公路 苗栗台中段	NORTH-SOUTH FREEWAY MIAOLI-TAICHUNG SECTION
穿越箱涵	UNDERCROSSING BOXES
詳圖	DETAILS
中華顧問工程司	CHINA ENGINEERING CONSULTANTS, INC.
日期 DATE AUG. '74	比例 SCALE AS SHOWN 圖號 SHEET SB-2

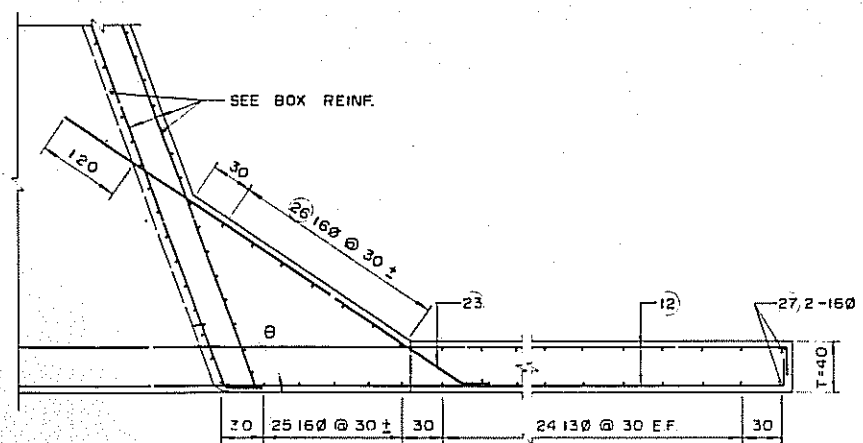
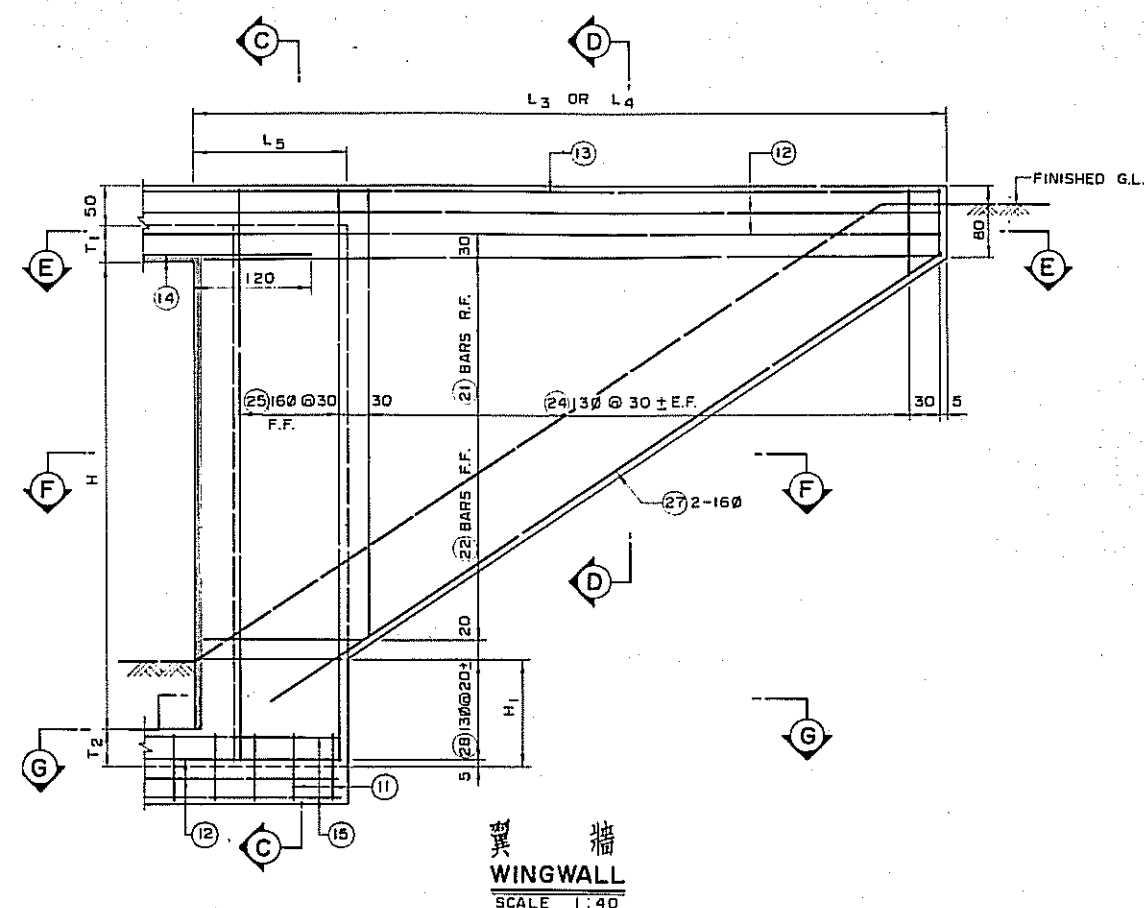

NOTE: 1. $\theta = \alpha$ OR $\theta = 180^\circ - \alpha$
2. $\theta \geq 90^\circ$ OR $\theta = 90^\circ$

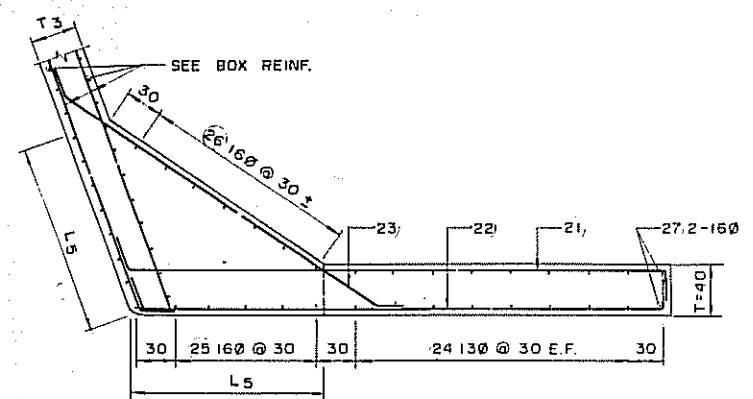

斷面圖 F-F
SECTION F-F
SCALE 1:30

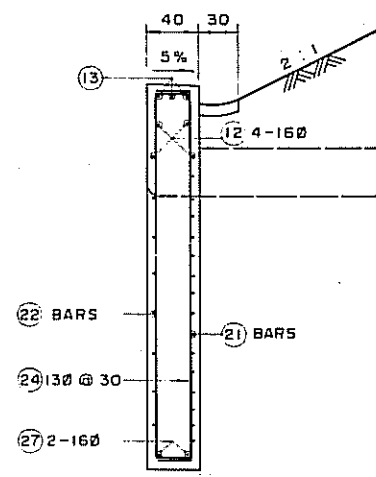
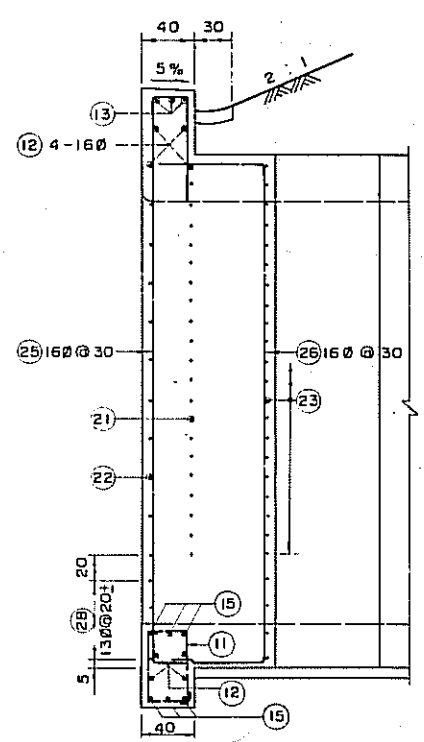

斷面圖 D-D
SECTION D-D
SCALE 1:30

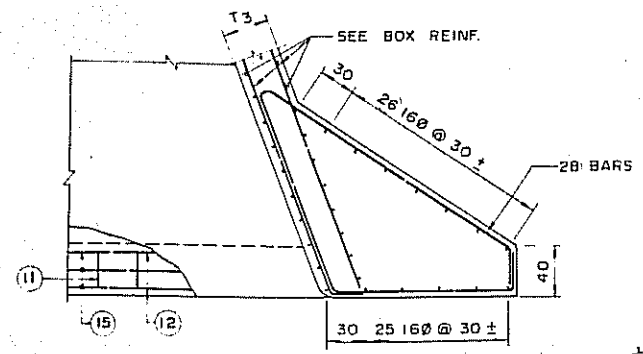

斷面圖 G-G
SECTION G-G
SCALE 1:30

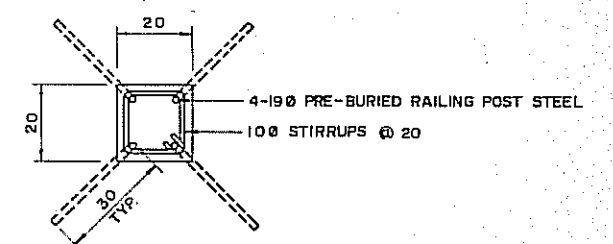
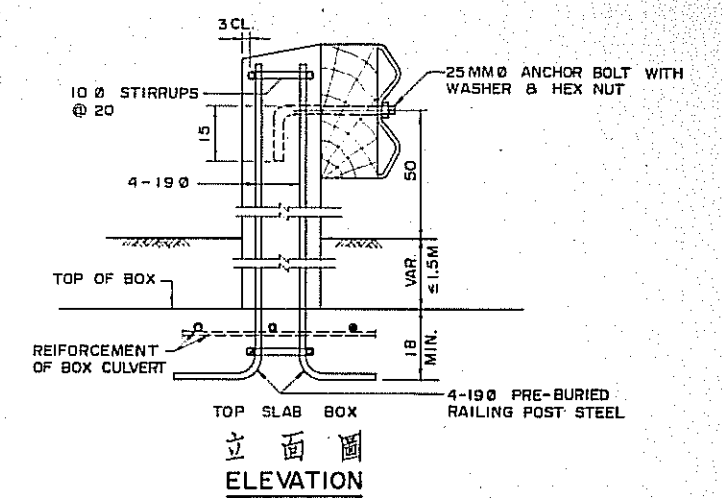

NOTE: THIS TYPE OF POST IS USED FOR BOXES WITH FILL $\leq 1.5M$ ONLY. FOR LOCATION SEE HIGHWAY PLANS.

翼牆尺寸及鋼筋表
LIST OF WINGWALL DIMENSIONS AND REINFORCING STEEL

TYPE	A	B	C	D	E	F	G	
L ₃ OR L ₄ (M)	-3.6	-5.0	-6.0	-5.4	-6.9	-6.4	-7.5	
L ₅ (M)	-0.7	-1.2	-1.8	-1.2	-2.0	-1.8	-2.3	
H (M)	2.0	3.0	3.0	4.0	4.0	4.8	4.8	
H ₁ (M)	-	-	-	0.5	0.5	0.8	0.8	
T (CM)	40	40	40	40	40	40	40	
REINFORCING STEEL	21	16Ø @ 15	16Ø @ 15	19Ø @ 15	19Ø @ 15	22Ø @ 15	19Ø @ 15	22Ø @ 15
	22	13Ø @ 30	13Ø @ 30	13Ø @ 30	13Ø @ 30	13Ø @ 30	13Ø @ 30	13Ø @ 30
	23	16Ø @ 15	16Ø @ 15	19Ø @ 15	19Ø @ 15	22Ø @ 15	19Ø @ 15	22Ø @ 15
	24	13Ø @ 30						
	25	16Ø @ 30						
	26	16Ø @ 30						
	12,	SEE CURB DETAIL						
	13,	SEE CURB DETAIL						
27	2-16Ø							
28	13Ø @ 20	13Ø @ 20	13Ø @ 20	13Ø @ 20	13Ø @ 20	13Ø @ 20	13Ø @ 20	

說明:

總說明參照圖 ST-1.

NOTE:

FOR GENERAL NOTES SEE SHEET ST-1.

修正	REVISIONS
項目	ITEM
日期	DATE

PROJECT 60

交通部台灣區高速公路工程局
TAIWAN AREA FREEWAY CONSTRUCTION BUREAU
中華民國
REPUBLIC OF CHINA

南北高速公路 NORTH-SOUTH FREEWAY
苗栗台中段 MIAOLI-TAICHUNG SECTION

穿越箱涵 UNDERCROSSING BOXES
翼牆詳圖 WINGWALL DETAILS

中華顧問工程司 CHINA ENGINEERING CONSULTANTS, INC.
日期 DATE AUG. '74 比例 SCALE AS SHOWN 圖號 SHEET SB-3

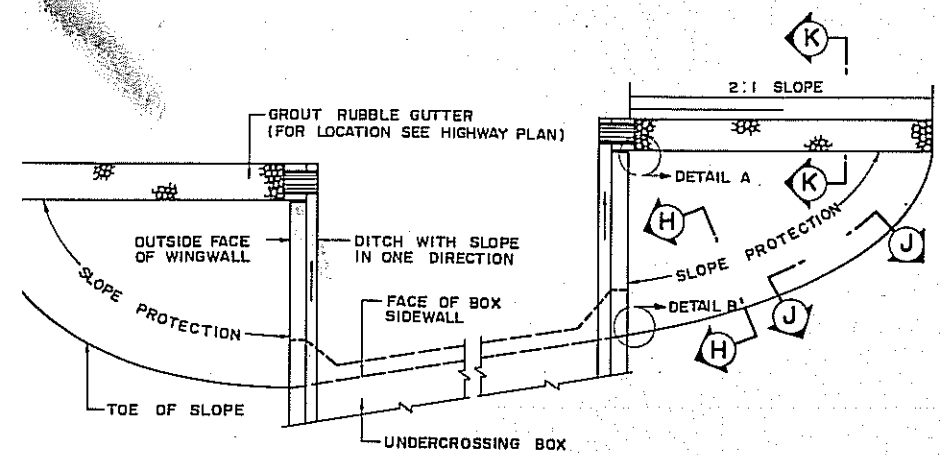

平面圖
PLAN VIEW

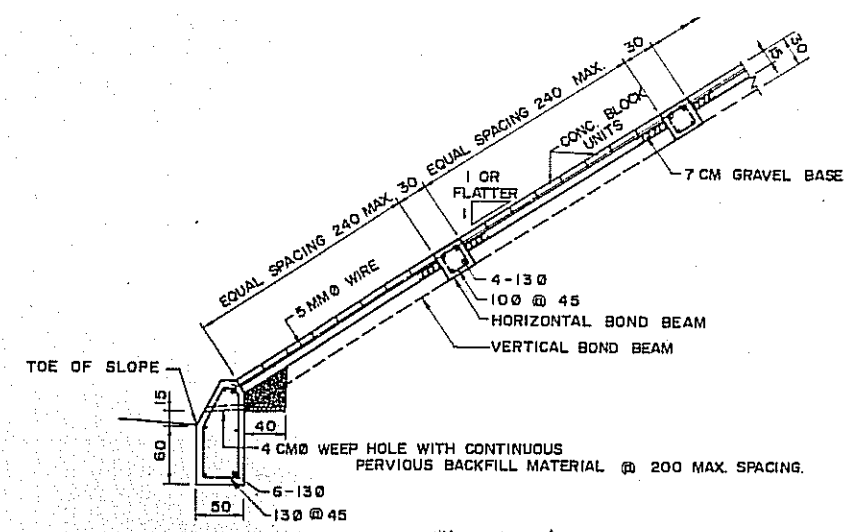

斷面圖 H—H
SECTION H—H
SCALE 1:40

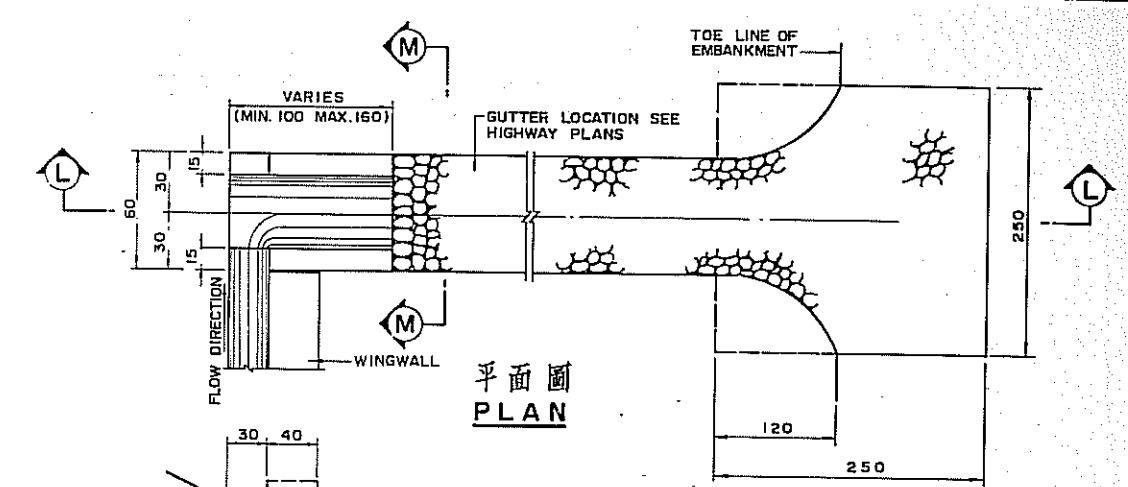

平面圖
PLAN

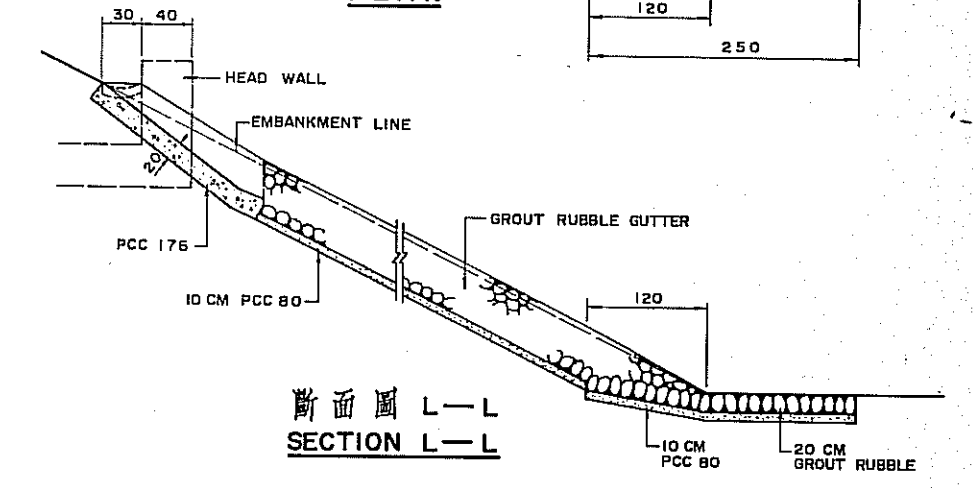

斷面圖 L—L
SECTION L—L

翼牆端部邊溝進水口
GUTTER INLET AT END OF WINGWALL
NOT TO SCALE

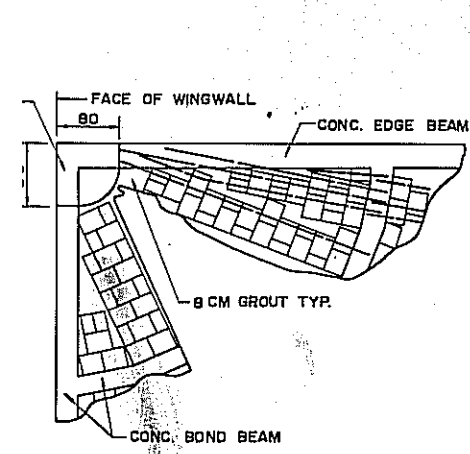

詳圖 A
DETAIL A
SCALE 1:50

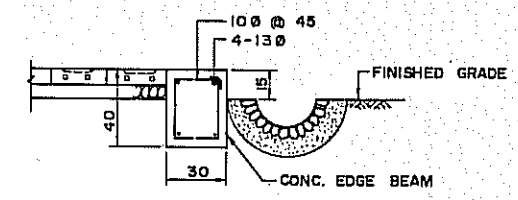

斷面圖 K—K
SECTION K—K
SCALE 1:20

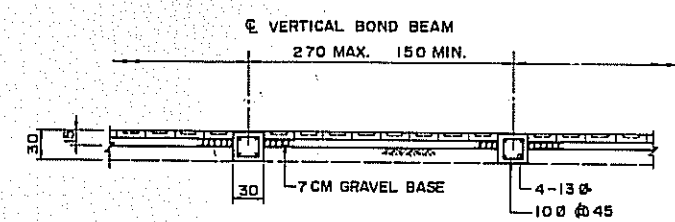

斷面圖 J—J
SECTION J—J
SCALE 1:40

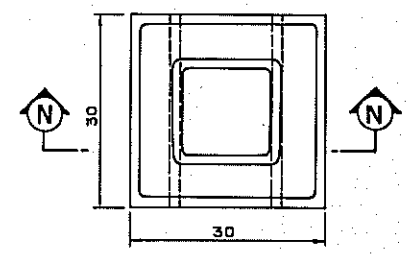

平面圖
PLAN

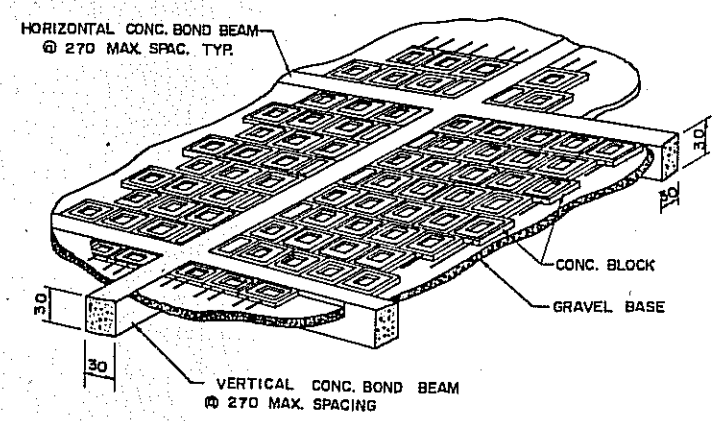

透視圖
PERSPECTIVE
N.T.S.

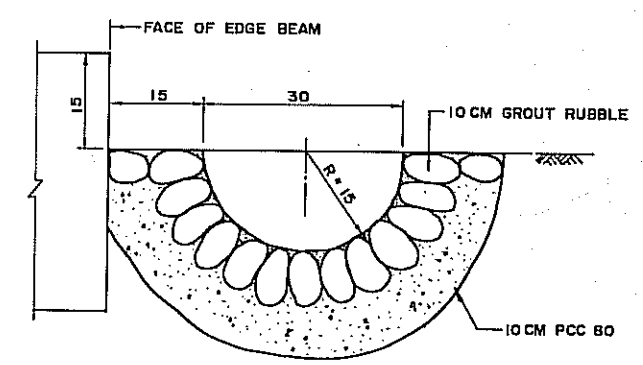

斷面圖 M—M
SECTION M—M
SCALE 1:6

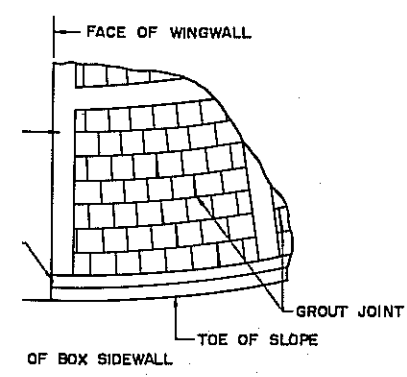

詳圖 B
DETAIL B
SCALE 1:50

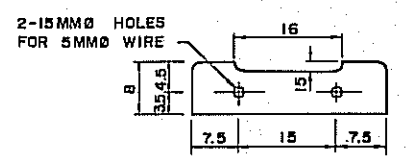

斷面圖 N—N
SECTION N—N

混凝土塊
CONCRETE BLOCK
SCALE 1:6

說明:

1. 總說明參照圖 ST-1.
2. 束樑與護坡基腳之混凝土，其 28 天之最小受壓強度應為 240 公斤/平方公分。

NOTES:

1. FOR GENERAL NOTES SEE SHEET ST-1.
2. CONCRETE FOR BOND BEAMS AND FOOTING OF SLOPE PROTECTION SHALL HAVE A MIN. COMPRESSIVE STRENGTH 240 KG/SQ. CM AT 28 DAYS.

PROJECT 60

修正 REVISIONS	項目 ITEM	日期 DATE

交通部台灣區高速公路工程局
TAIWAN AREA FREEWAY CONSTRUCTION BUREAU
中華民國
REPUBLIC OF CHINA

南北高速公路
MIAOLI-TAICHUNG SECTION
苗栗台中段

穿越箱涵
UNDERCROSSING BOXES
護坡及邊溝詳圖
SLOPE PROTECTION & GUTTER DETAILS

中華顧問工程司
CHINA ENGINEERING CONSULTANTS, INC.

日期 DATE AUG. '74 比例 SCALE AS SHOWN 圖號 SHEET SB-4

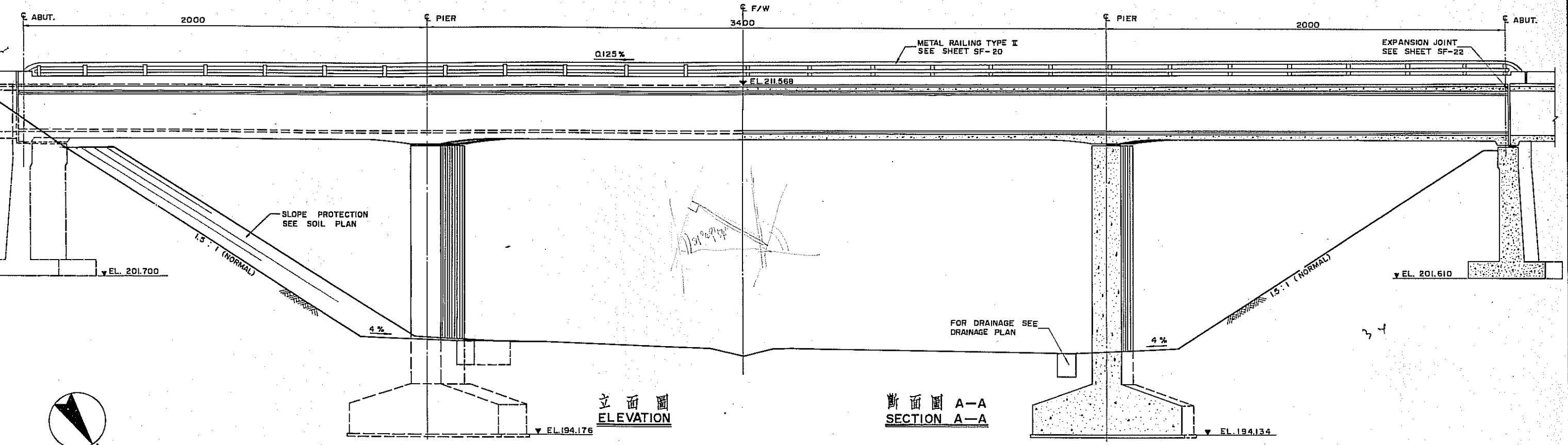

立面圖
ELEVATION

斷面圖 A-A
SECTION A-A

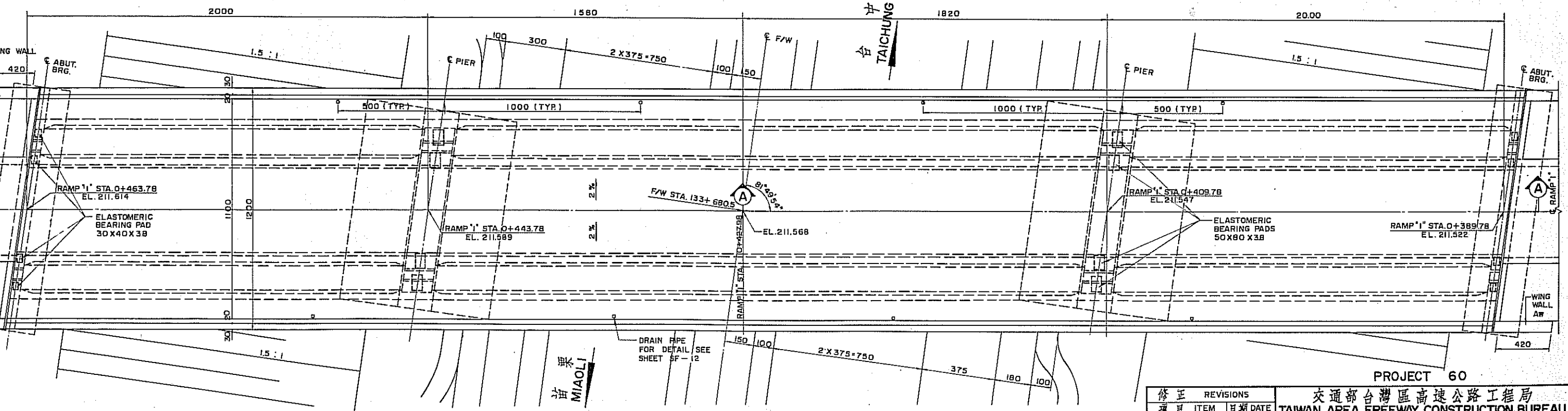

平面圖
PLAN

說明：詳說明參照圖 SF-18。
NOTE: FOR GENERAL NOTES SEE SHEET SF-18.

修正 REVISIONS	項目 ITEM	日期 DATE

交通部台灣區高速公路工程局
TAIWAN AREA FREEWAY CONSTRUCTION BUREAU
中華民國
REPUBLIC OF CHINA
南北高速公路
NORTH-SOUTH FREEWAY
苗栗台中段
MIAOLI-TAICHUNG SECTION
渡槽 (133+680.50)
FLUME
總平面圖
GENERAL PLAN
中華顧問工程司
CHINA ENGINEERING CONSULTANTS, INC.
日期 DATE AUG. 74 比例 SCALE 1:100 圖號 SHEET SF-6

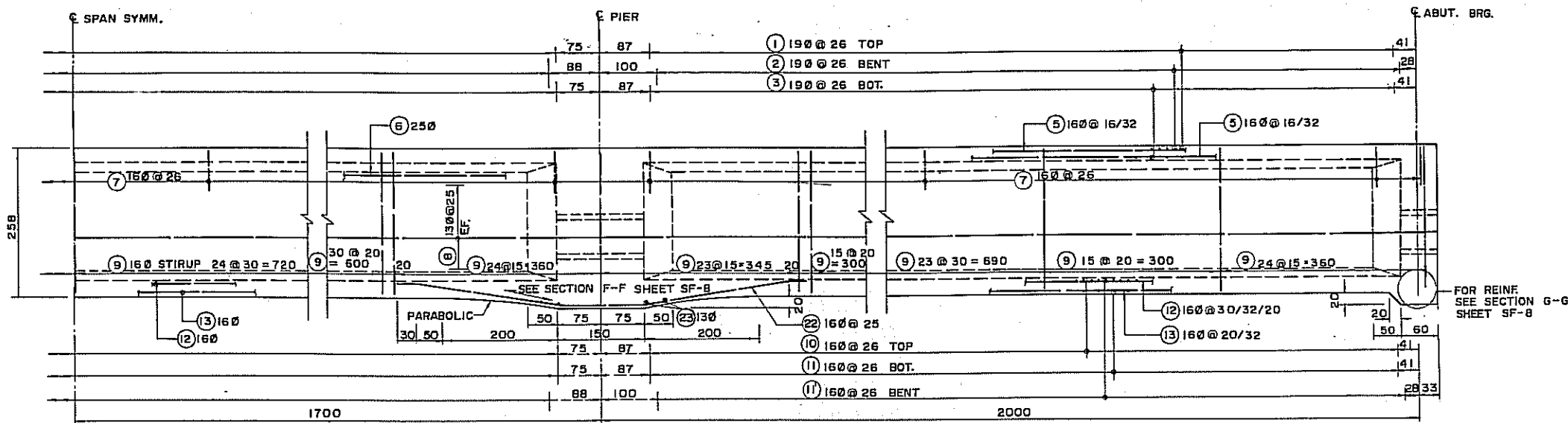

斷面圖 B-B
SECTION B-B

鋼筋表
LIST OF REINFORCING STEELS

SHAPE	NOMINAL DIA. (MM)	REMARK
(1)	19 Ø	@ 26
(2)	19 Ø	@ 26
(3)	19 Ø	@ 26
(4)	16 Ø	@ 26
(5)	16 Ø	@ 16/32
(6)	25 Ø	
(7)	16 Ø	@ 26
(8)	13 Ø	@ 25
(9)	16 Ø	@ 15/20
(10)	16 Ø	@ 26
(11)	16 Ø	@ 26
(12)	16 Ø	@ 20/30/32
(13)	16 Ø	@ 20/32
(14)	16 Ø	@ 26
(15)	13 Ø	@ 26
(16)	16 Ø	
(17)	22 Ø / 25 Ø	
(18)	22 Ø / 25 Ø	(MID DIAPH) (END DIAPH)
(19)	22 Ø	
(20)	25 Ø	
(21)	16 Ø	@ 15
(22)	16 Ø	@ 25
(23)	13 Ø	@ 30
(24)	13 Ø	@ 25
(25)	25 Ø	
(26)	10 Ø	BEHIND FREYSSINET CONE ONLY
(27)	13 Ø	@ 15
(28)	13 Ø	@ 30
(29)	13 Ø	

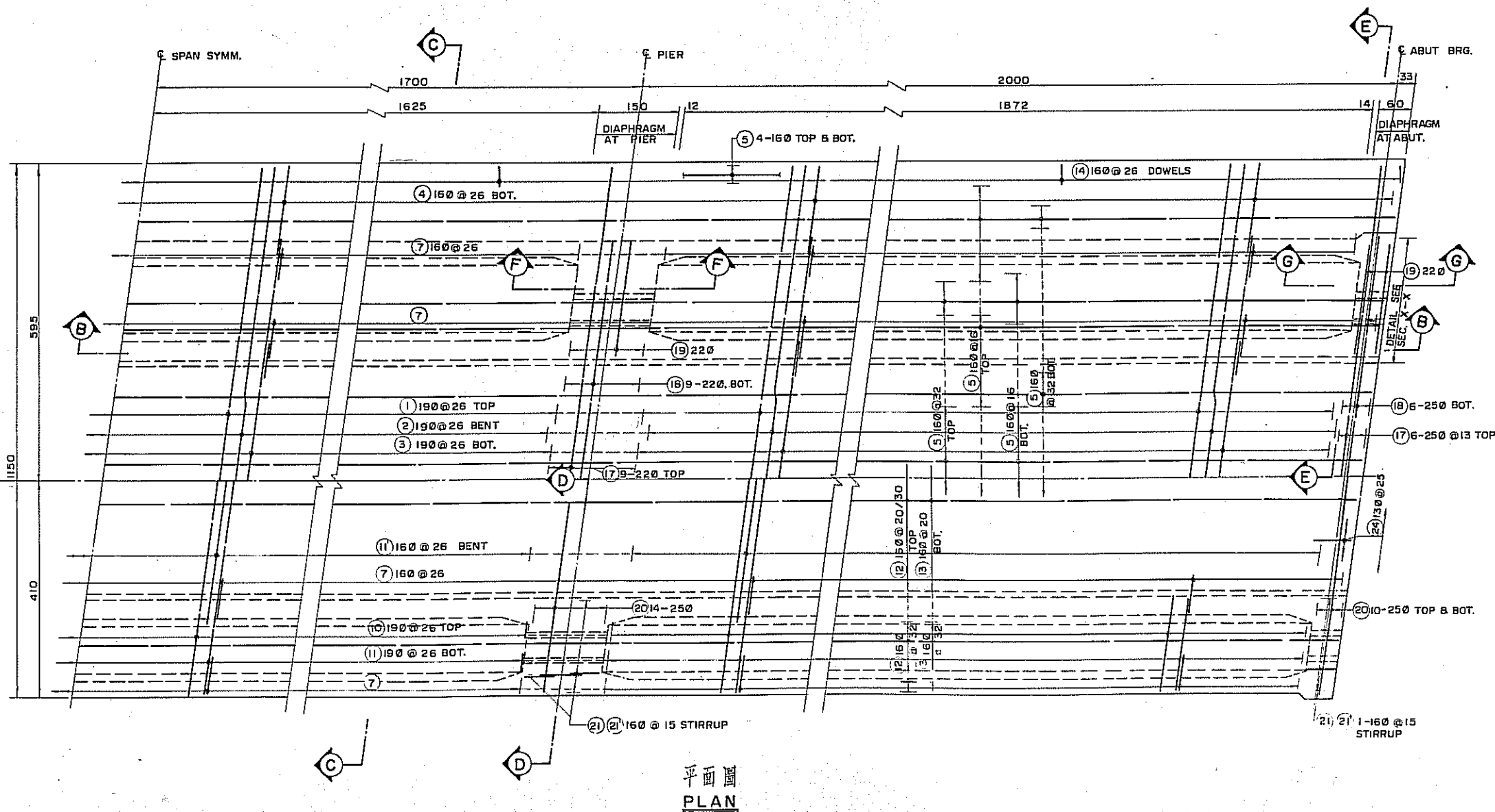

平面圖
PLAN

說明: 詳說明參照圖 SF-18.

NOTE: FOR GENERAL NOTES SEE SHEET SF-18.

PROJECT 60

修正 REVISIONS	項目 ITEM	日期 DATE
交通部台灣區高速公路工程局 TAIWAN AREA FREEWAY CONSTRUCTION BUREAU 中華民國 REPUBLIC OF CHINA		
南北高速公路 苗栗台中段 NORTH-SOUTH FREEWAY MIAOLI-TAICHUNG SECTION		
波槽 (133+680.50) 上部結構鋼筋詳圖 FLUME SUPERSTR. REINF. DETAILS		
中華顧問工程司 CHINA ENGINEERING CONSULTANTS, INC.		
日期 DATE AUG. '74 比例 SCALE 1:50 圖號 SHEET SF-7		

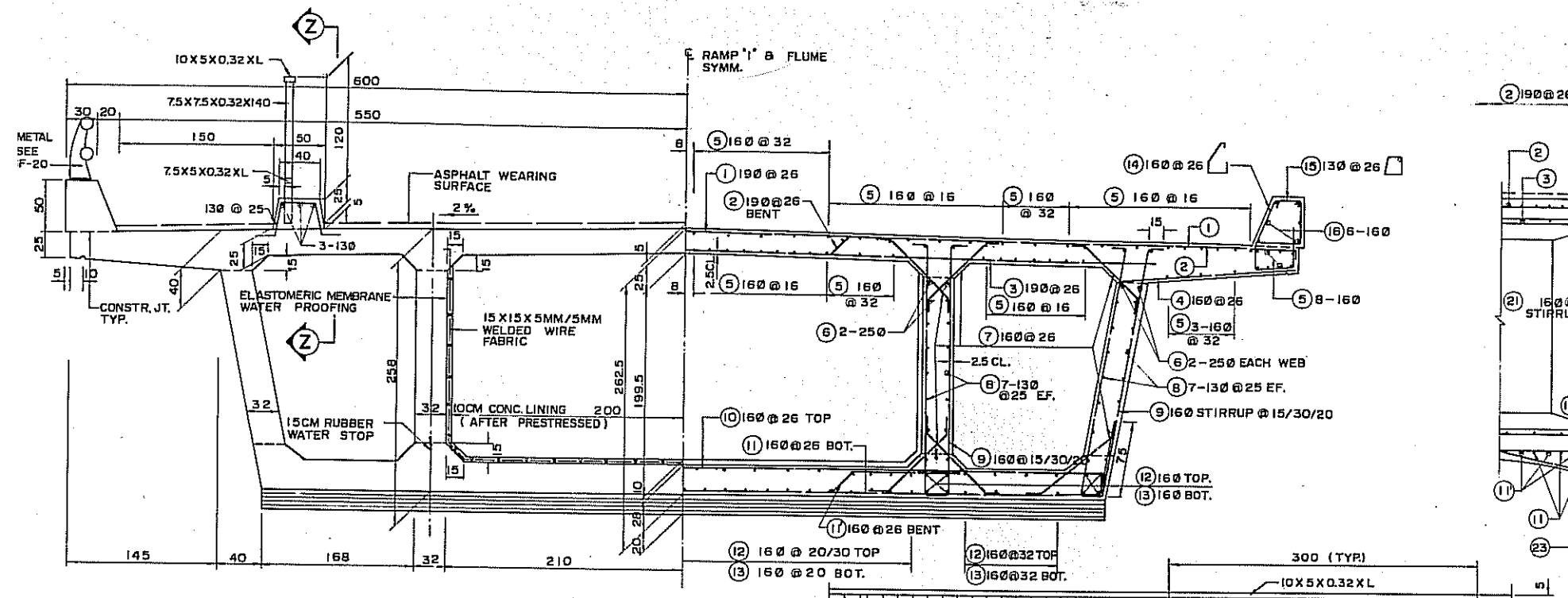

断面圖 C-C
SECTION C-C
SCALE 1:30

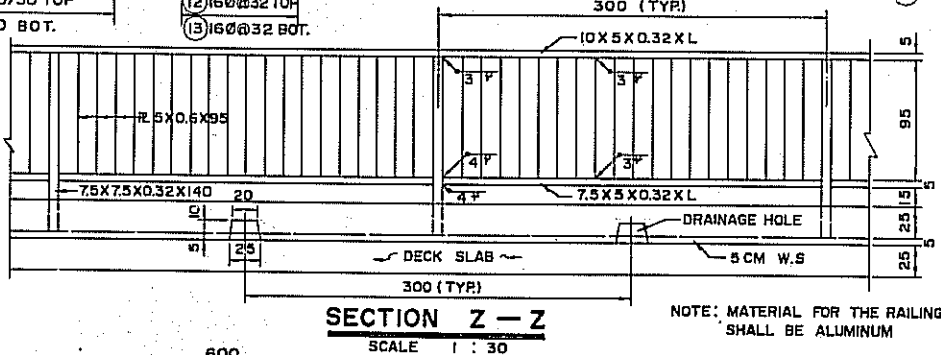

SECTION Z-Z
SCALE 1:30

NOTE: MATERIAL FOR THE RAILING SHALL BE ALUMINUM

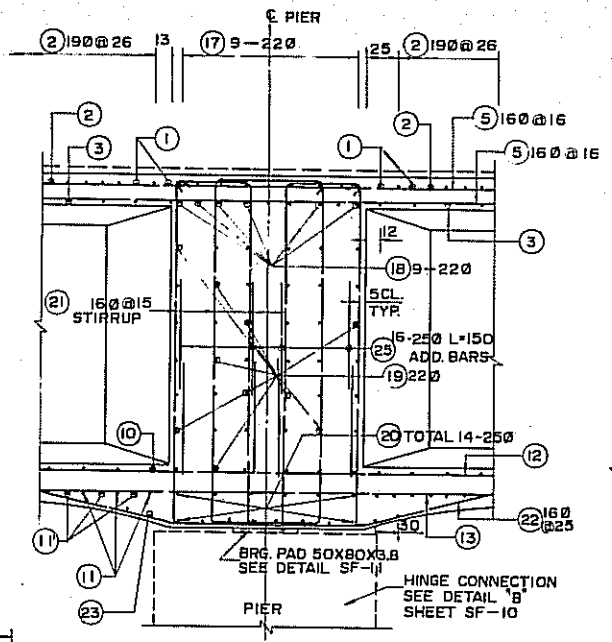

断面圖 F-F
SECTION F-F
SCALE 1:30

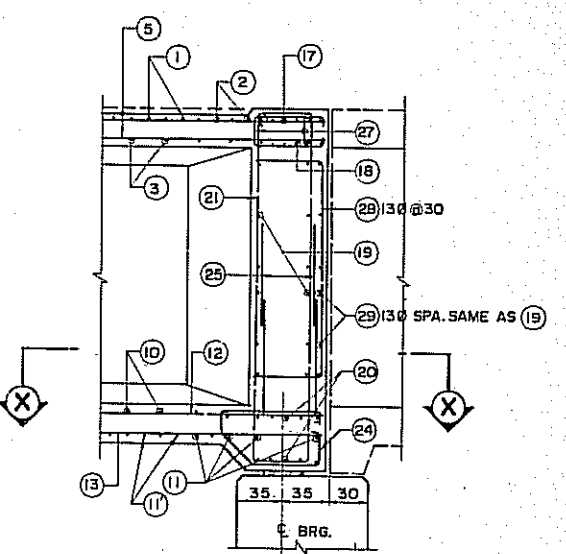

断面圖 G-G
SECTION G-G
SCALE 1:30

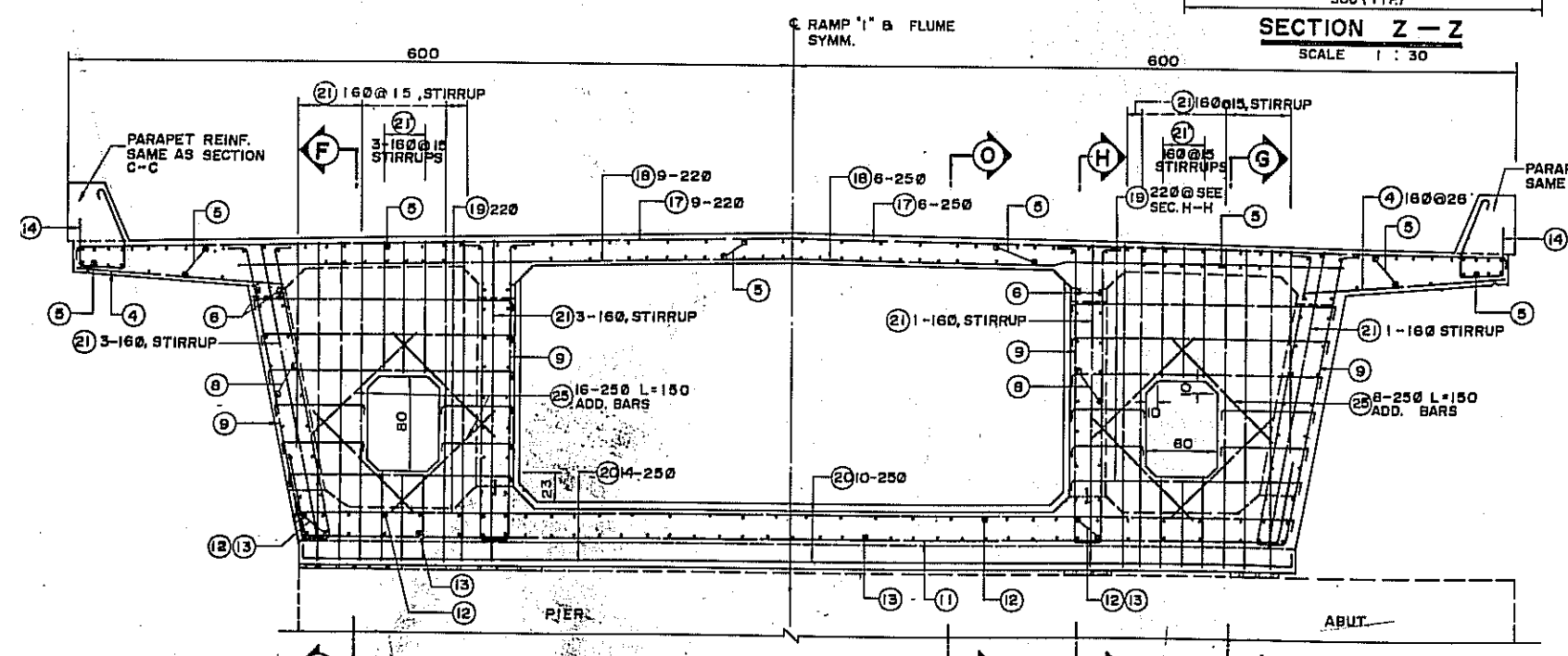

断面圖 D-D
SECTION D-D
SCALE 1:30

断面圖 E-E
SECTION E-E
SCALE 1:30

断面圖 X-X
SECTION X-X
SCALE 1:30

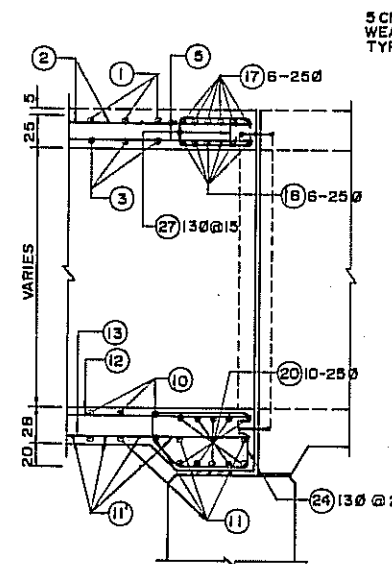

断面圖 O-O
SECTION O-O
SCALE 1:30

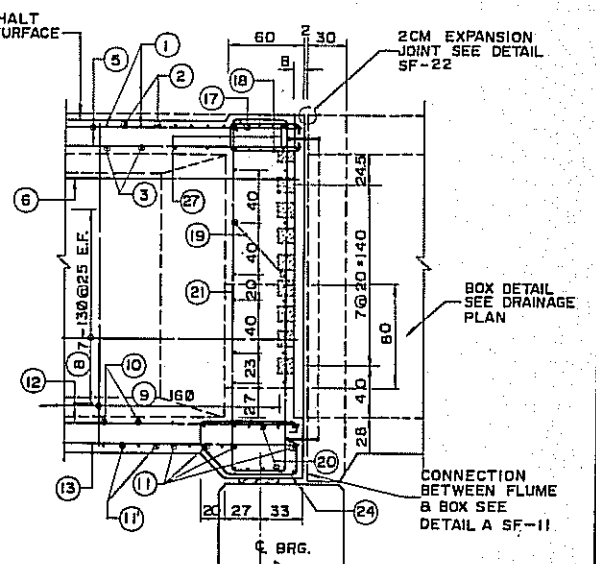

断面圖 H-H
SECTION H-H
SCALE 1:30

修正	REVISIONS	項目	ITEM	日期	DATE

PROJECT 60
交通部台灣區高速公路工程局
TAIWAN AREA FREEWAY CONSTRUCTION BUREAU
中華民國
南北高速公路
NORTH-SOUTH FREEWAY
苗栗台中段
MIAOLI-TAICHUNG SECTION
波槽 (133+680.50)
FLUME
上部結構鋼筋及詳圖
SUPERSTR. REINF. & DETAILS
中華顧問工程司
CHINA ENGINEERING CONSULTANTS, INC.
日期 DATE AUG. '74 比例 SCALE AS SHOWN 圖號 SHEET SF-8

鋼筋表
LIST OF REINFORCING STEELS

SHAPE	NOMINAL DIA.(MM)	REMARK
	32 Ø	@ 24
	32 Ø	@ 24
	32 Ø	@ 18
	22 Ø	@ 18
	13 Ø	@ 30
	13 Ø	@ 30
	13 Ø	@ 30
	16 Ø	
	13 Ø	@ 25
	10 Ø	@ 60
	10 Ø	@ 25
	16 Ø	@ 15
	13 Ø	@ 30
	13 Ø	@ 30
	13 Ø	@ 15/30
	13 Ø	@ 30
	13 Ø	
	19 Ø	
	22 Ø	@ 18
	13 Ø	@ 25
	13 Ø	@ 30
	22 Ø	@ 18
	13 Ø	@ 30
	13 Ø	

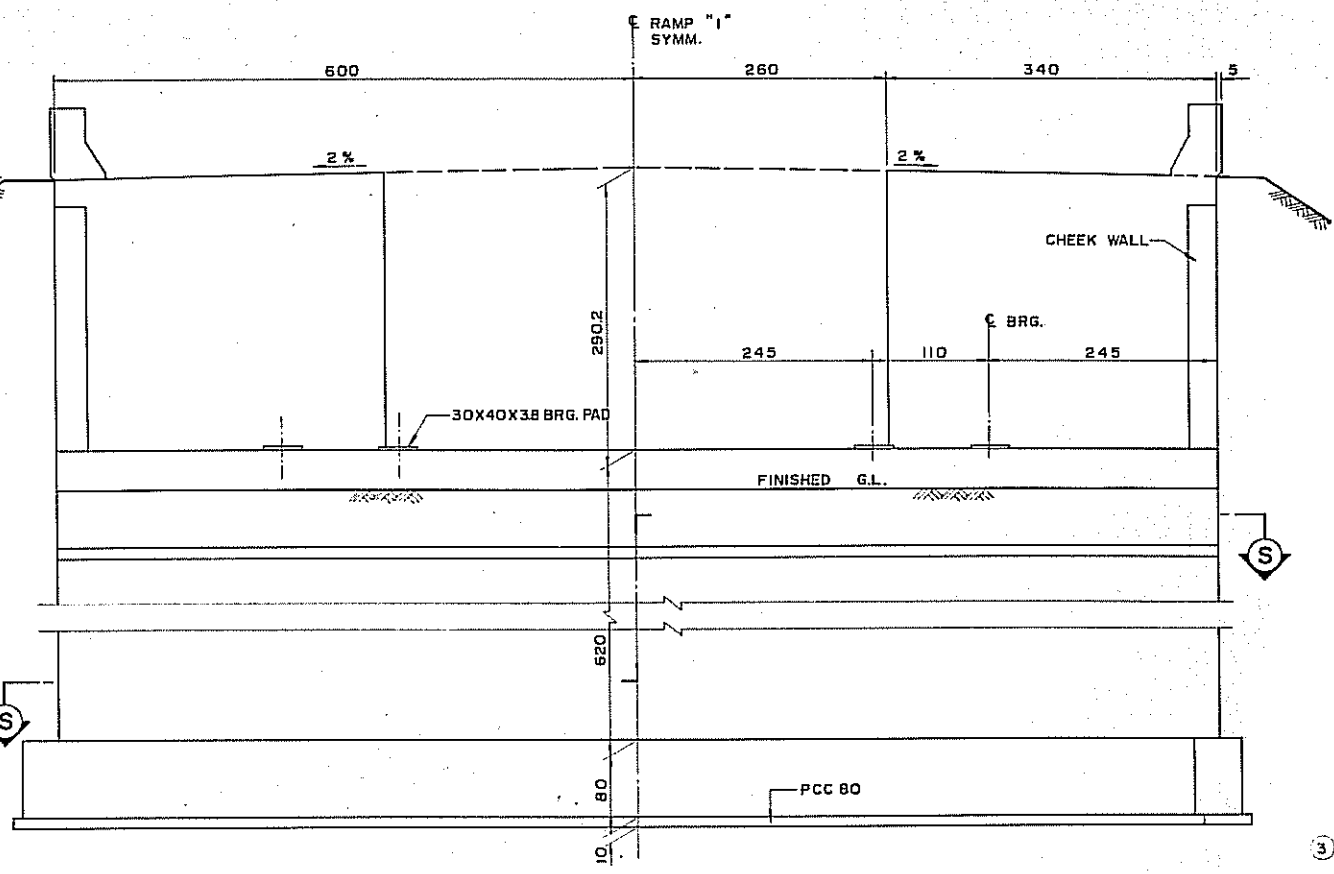

視面圖 "A"
VIEW "A"
SCALE 1:40

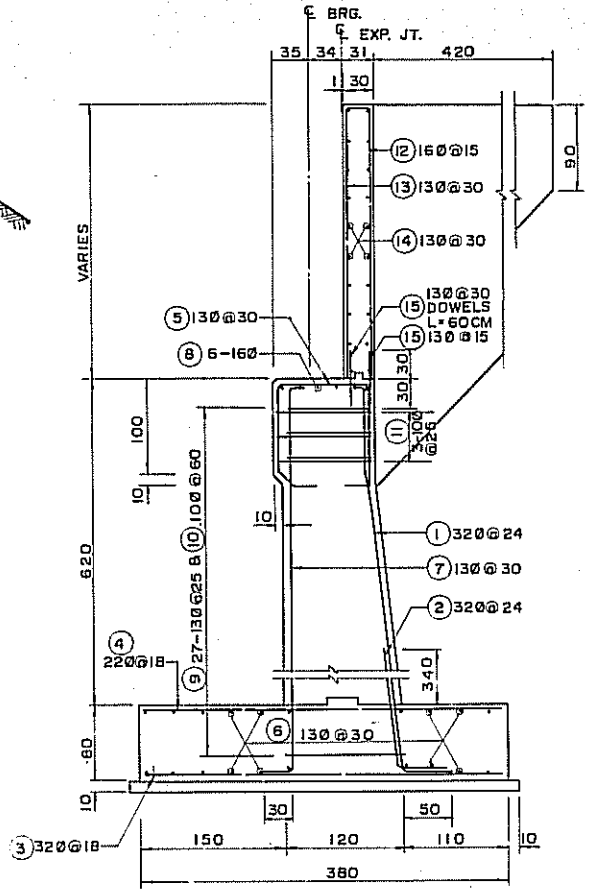

斷面圖 Q-Q
SECTION Q-Q
SCALE 1:40

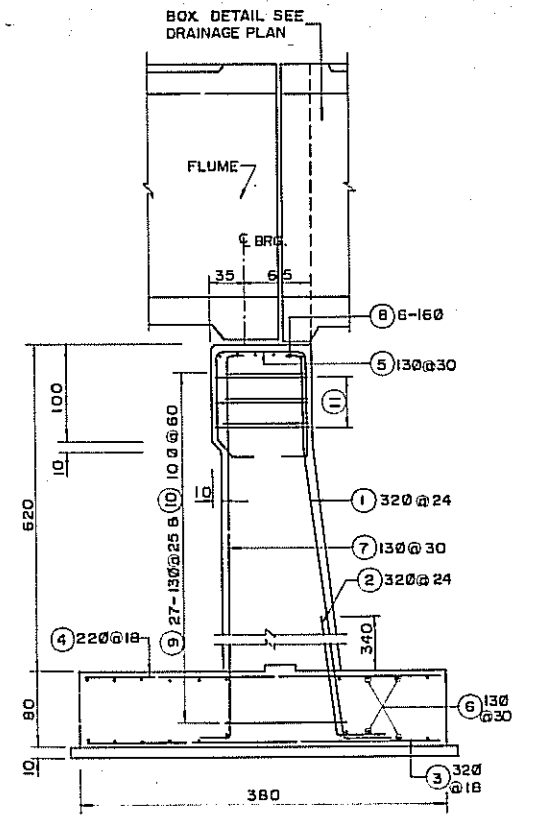

斷面圖 R-R
SECTION R-R
SCALE 1:40

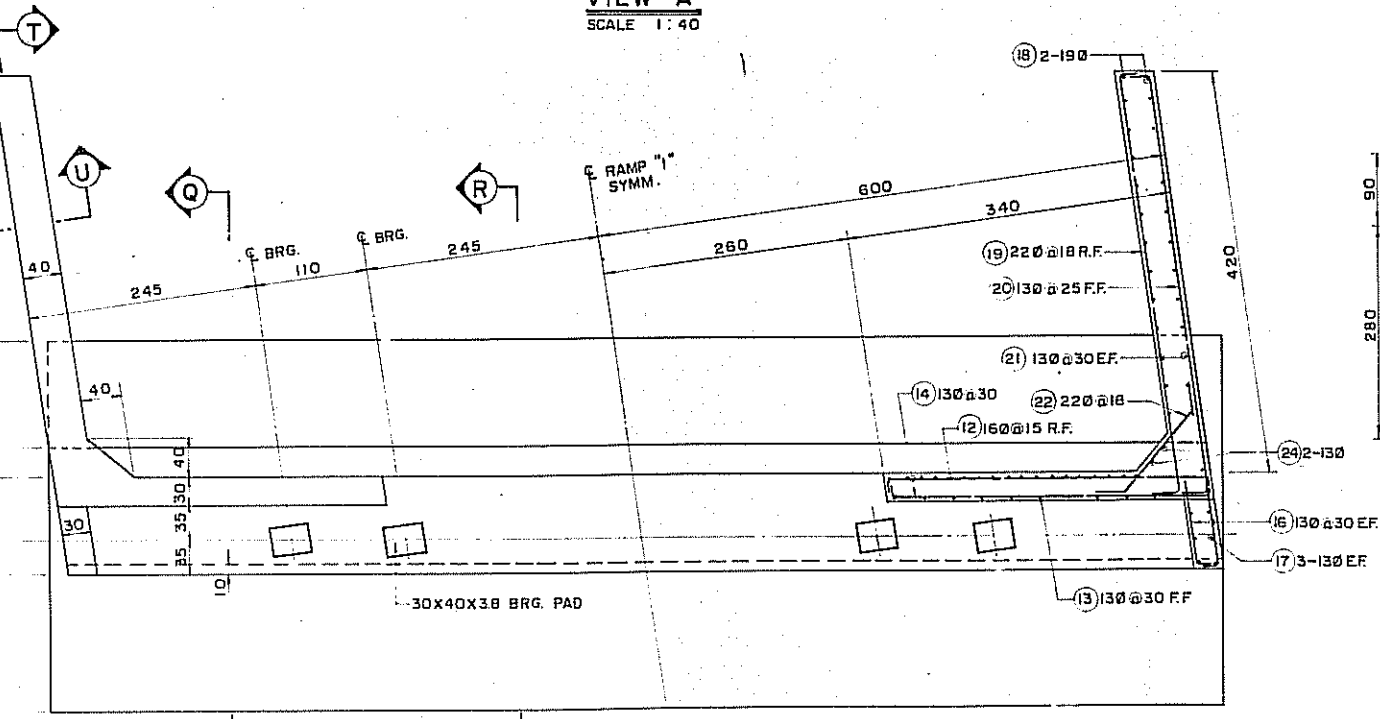

平面圖
PLAN
SCALE 1:40

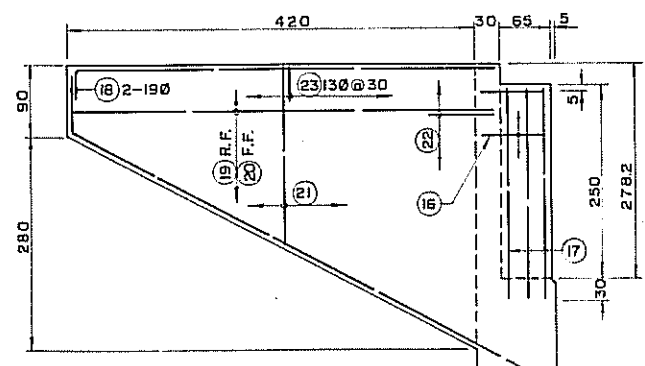

斷面圖 T-T
SECTION T-T
SCALE 1:50

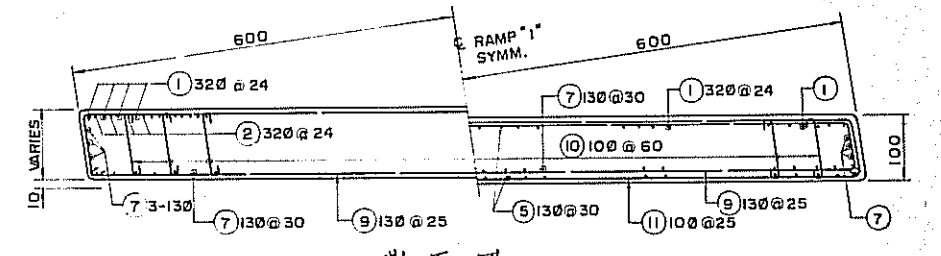

斷面圖 S-S
SECTION S-S
SCALE 1:60

說明: 1. 總說明參照圖 SF-18.
2. 設計最大基礎壓力 = 61 噸/平方公尺。

NOTES: 1. FOR GENERAL NOTES SEE SHEET SF-18.
2. MAX. DESIGN FOUNDATION PRESSURE = 61 T/M²

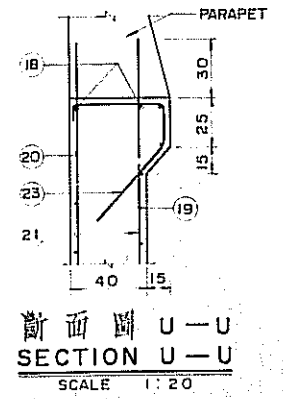

斷面圖 U-U
SECTION U-U
SCALE 1:20

PROJECT 60

修正	REVISIONS	項目	ITEM	日期	DATE

交通部台灣區高速公路工程局
TAIWAN AREA FREEWAY CONSTRUCTION BUREAU
中華民國
REPUBLIC OF CHINA
南北高速公路
NORTH-SOUTH FREEWAY
苗栗台中段
MIAOLI-TAICHUNG SECTION
波槽 (133 + 680.50)
FLUME
橋台
ABUTMENT
中華顧問工程司
CHINA ENGINEERING CONSULTANTS, INC.
日期 DATE AUG. '74 比例 SCALE AS SHOWN 圖號 SHEET SF-10

鋼筋表
LIST OF REINFORCING STEELS

SHAPE	NOMINAL DIA. (MM)	REMARK
①	25 Ø	@ 10
②	25 Ø	@ 30
③	25 Ø	@ 25
④	16 Ø	@ 40
⑤	16 Ø	@ 15/20/30
⑥	13 Ø	@ 15/20/30
⑦	32 Ø	@ 15
⑧	32 Ø	@ 15
⑨	13 Ø	@ 15
⑩	16 Ø	@ 17
⑪	10 Ø	@ 15

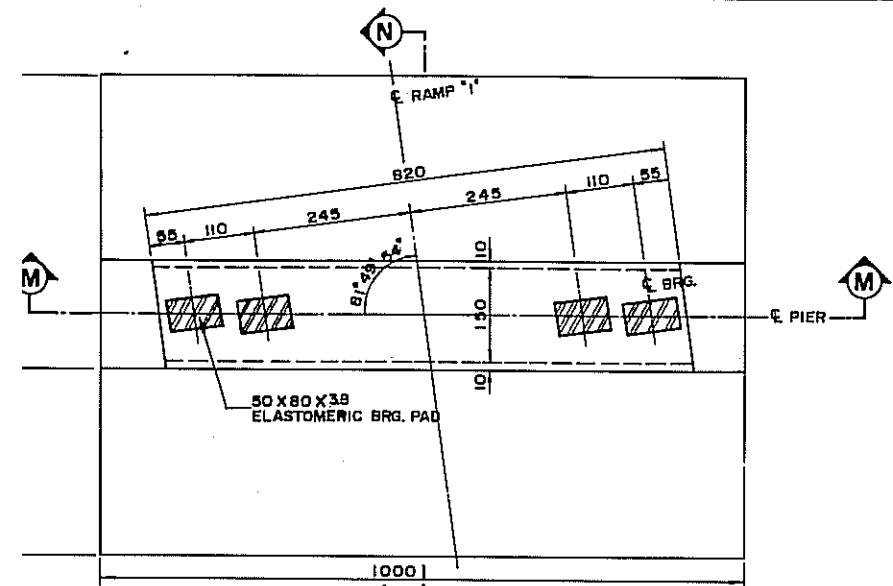

平面圖
PLAN
SCALE 1:60

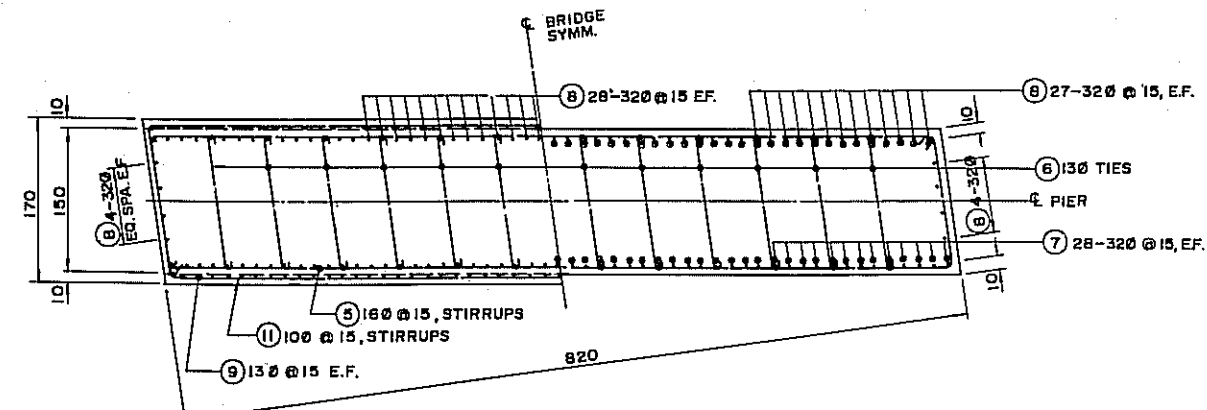

斷面圖 P-P
SECTION P-P
SCALE 1:40

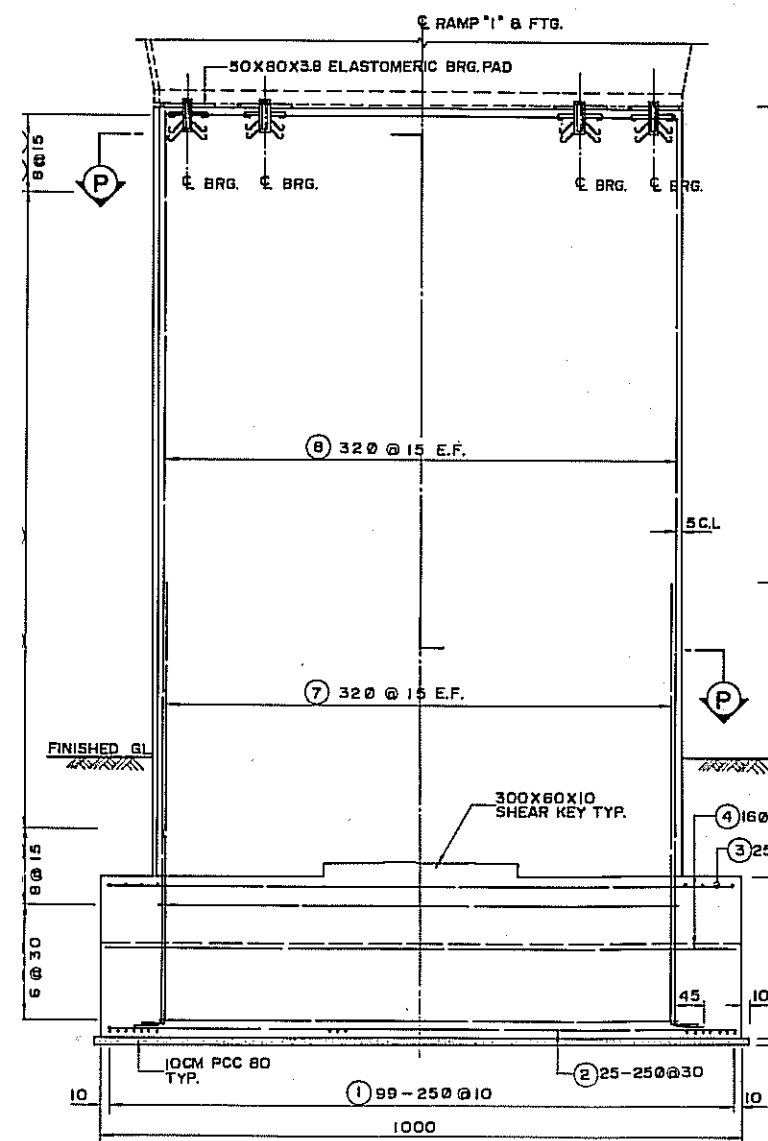

斷面圖 M-M
SECTION M-M
SCALE 1:60

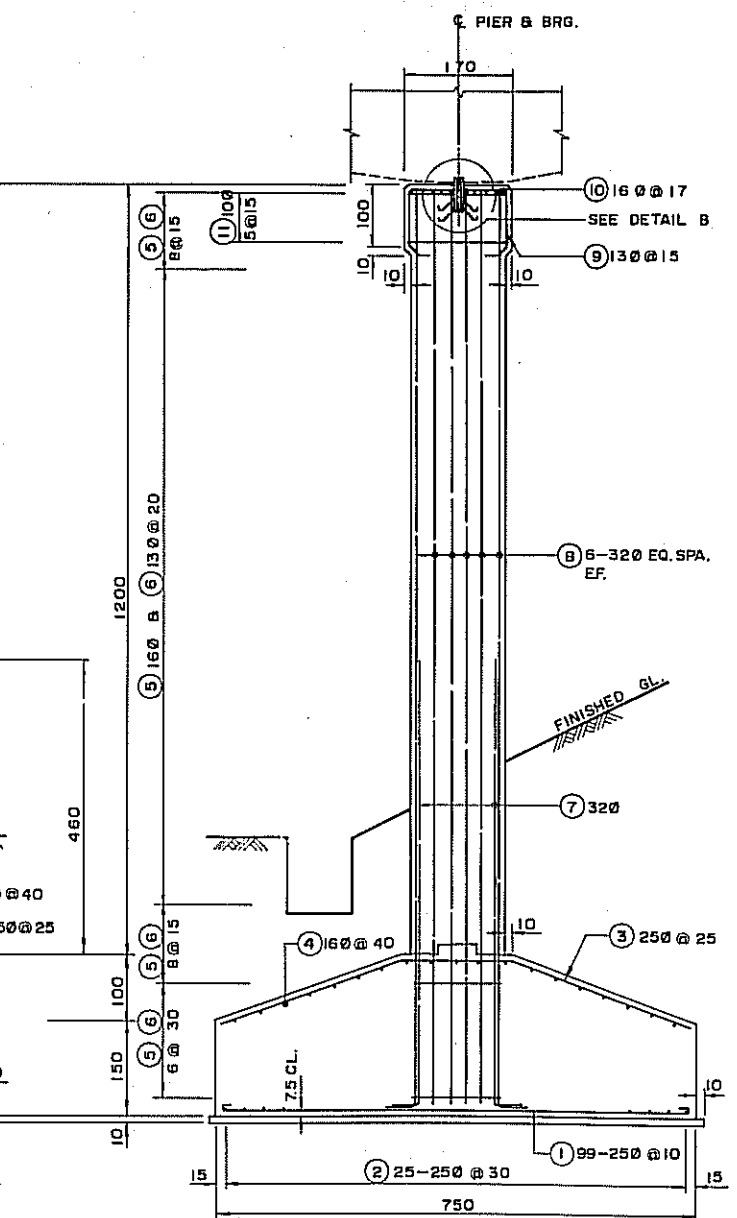

斷面圖 N-N
SECTION N-N
SCALE 1:60

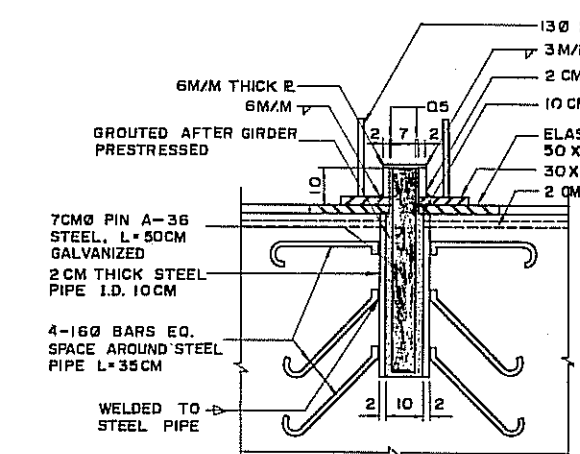

詳圖 B
DETAIL B
SCALE 1:10

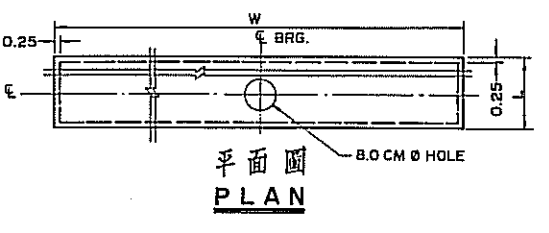

平面圖
PLAN

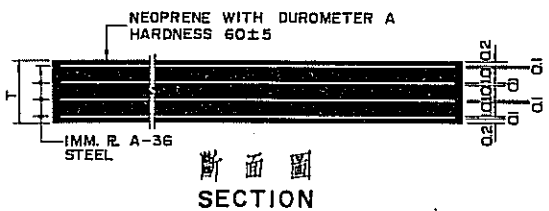

斷面圖
SECTION

合成橡膠支承版詳圖
ELASTOMERIC BRG. PAD DETAILS
DIMENSIONS (L X W X T) ARE IN CM
N.T.S.

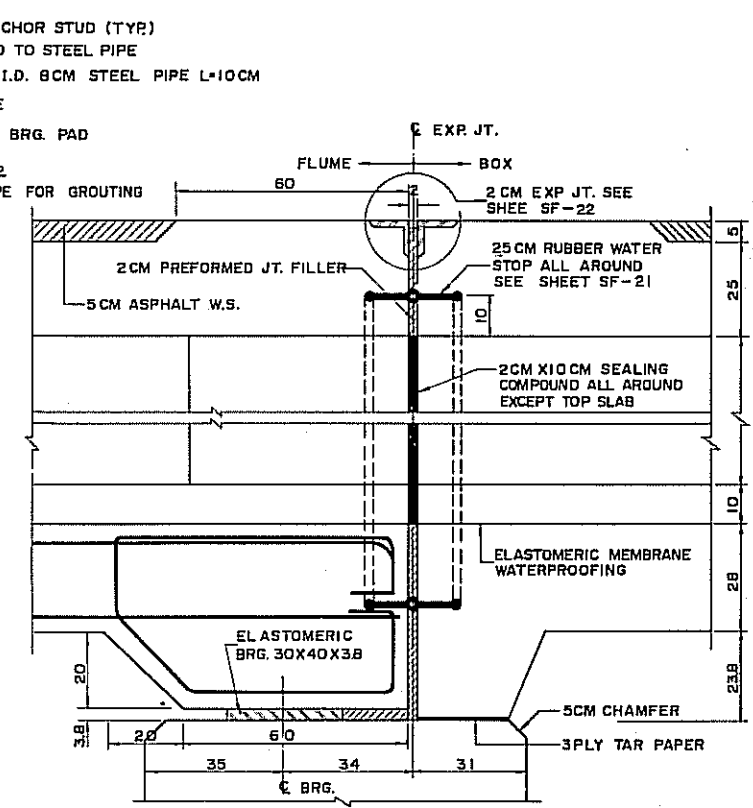

詳圖 A
DETAIL A
SCALE 1:10

修正 REVISIONS	項目 ITEM	日期 DATE

交通部台灣區高速公路工程局
TAIWAN AREA FREEWAY CONSTRUCTION BUREAU
中華民國
REPUBLIC OF CHINA
南北高速公路 NORTH-SOUTH FREEWAY
苗栗台中段 MIAOLI-TAICHUNG SECTION
渡槽 (133+680.50) FLUME
橋墩 PIER
中華顧問工程司 CHINA ENGINEERING CONSULTANTS, INC.
日期 DATE AUG. '74 比例 SCALE AS SHOWN 圖號 SHEET SF-11

PROJECT 60

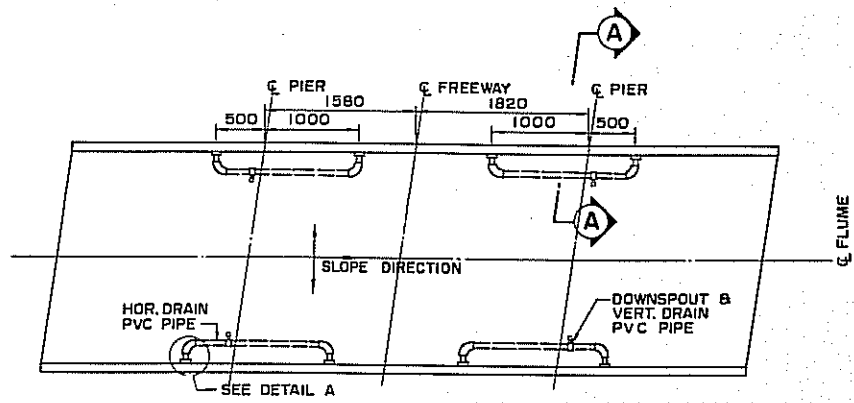

平面圖
PLAN
N.T.S.

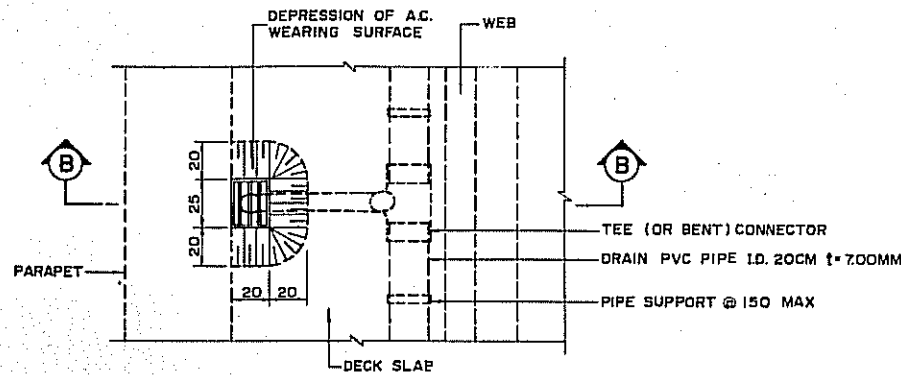

平面圖
PLAN

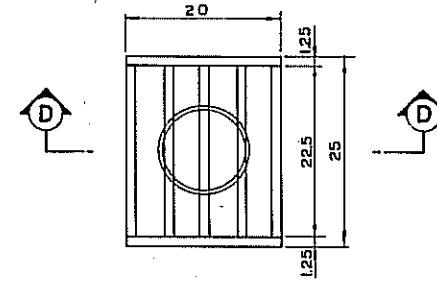

平面圖
PLAN

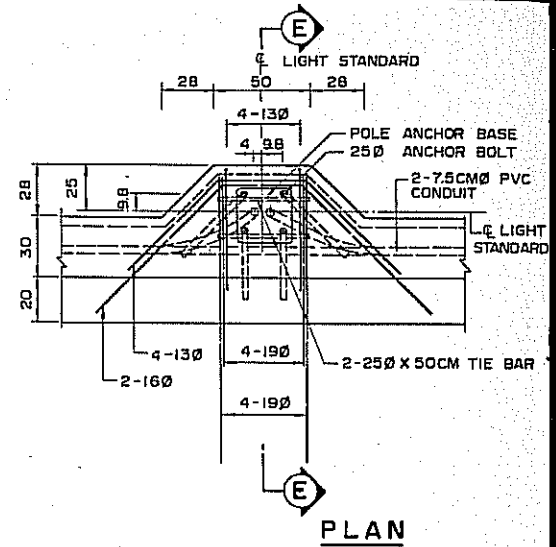

PLAN

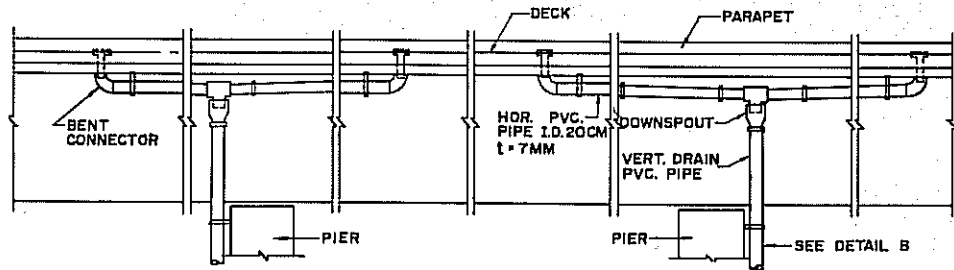

立面圖
ELEVATION
N.T.S.

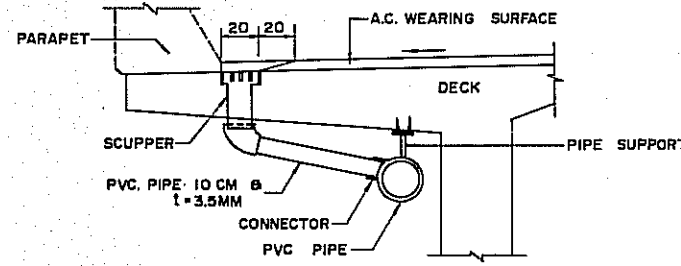

斷面圖 B-B
SECTION B-B

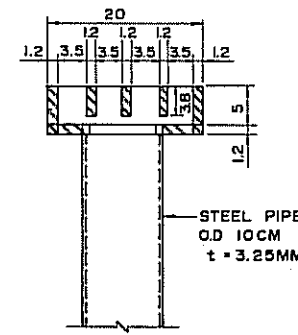

斷面圖 D-D
SECTION D-D

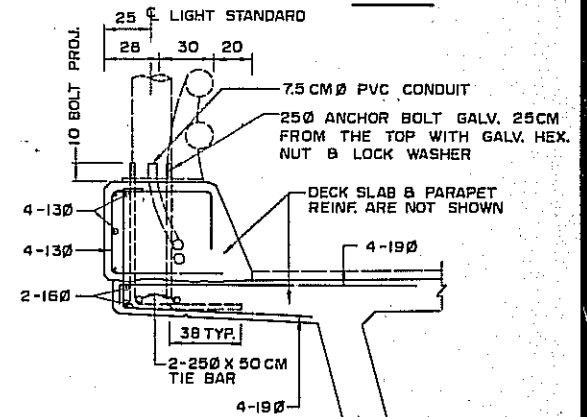

燈柱基座詳圖
LIGHT STANDARD SUPPORT DETAILS
SCALE 1:20

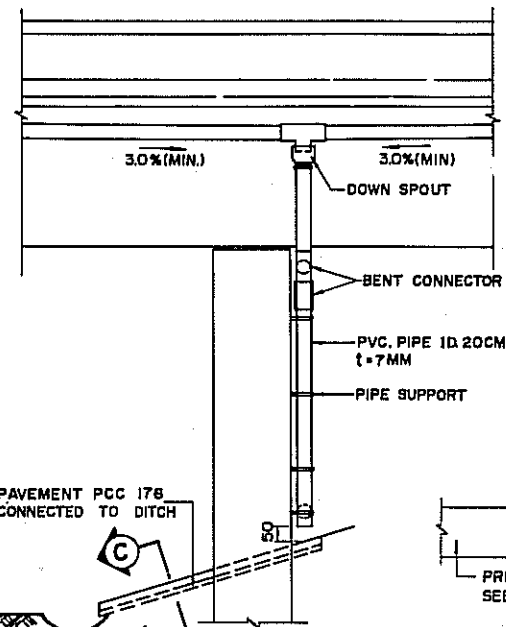

詳圖 B
DETAIL B
N.T.S.

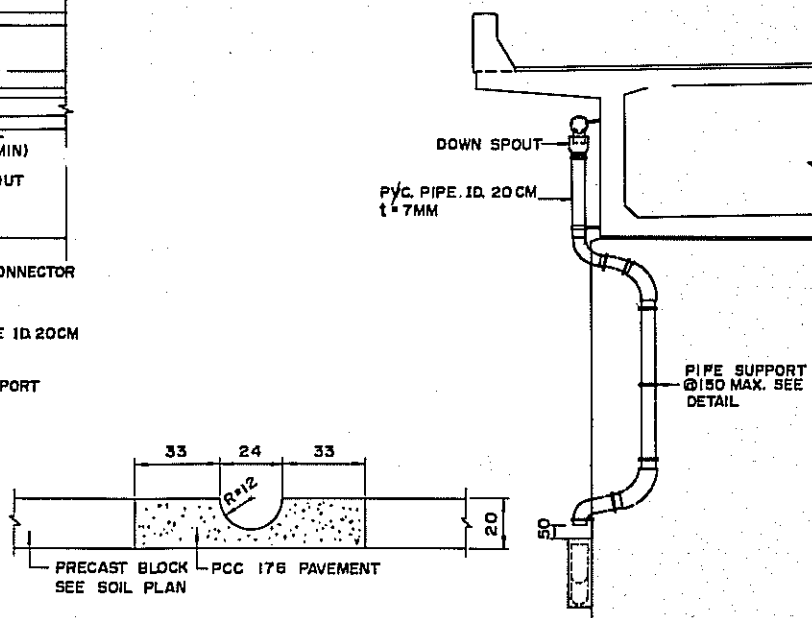

斷面圖 C-C
SECTION C-C
N.T.S.

斷面圖 A-A
SECTION A-A
N.T.S.

詳圖 A
DETAIL A
SCALE 1:20

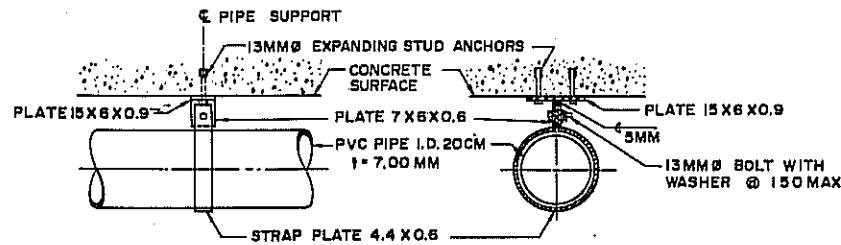

正視圖
FRONT VIEW

斷面圖
SECTION

圓管支承詳圖
PIPE SUPPORT DETAILS
SCALE 1:10

洩水孔詳圖
SCUPPER DETAIL
SCALE 1:5

說明:

1. 所有尺寸除註明者外均以公分計。
2. 洩水孔須由鑄鋼或焊接鋼板製成。
3. 焊接材料及方法須符合美國焊接學會規範。
4. 鋼材組件於製成後，須經熱浸鍍鋅處理。
5. 燈柱基座位置參閱照明設施。

NOTES:

1. ALL DIMENSIONS ARE IN CM UNLESS OTHERWISE NOTED.
2. SCUPPER SHALL BE MADE OF CAST STEEL OR WELDED PLATE.
3. WELDING MATERIALS AND METHODS SHALL CONFORM TO A.W.S. "SPECIFICATIONS FOR WELDED HIGHWAY AND RAILWAY BRIDGE."
4. STEEL COMPONENTS SHALL BE HOT DIP GALVANIZED AFTER FABRICATION.
5. FOR LIGHT STANDARD LOCATION SEE LIGHTING PLAN.

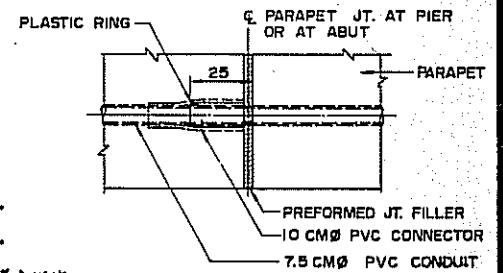

CONDUIT THRU PARAPET JT. DETAIL
N.T.S.

PROJECT 60

修正	REVISIONS	項目	ITEM	日期	DATE

交通部台灣區高速公路工程局
TAIWAN AREA FREEWAY CONSTRUCTION BUREAU
中華民國
南北高速公路 NORTH-SOUTH FREEWAY
苗栗台中段 MIAOLI-TAICHUNG SECTION
溝槽 (133+680.50) FLUME
洩水孔與排水管詳圖 SCUPPER & DOWNPIPE DETAILS
中華顧問工程司 CHINA ENGINEERING CONSULTANTS, INC.
日期 DATE AUG. '74 比例 SCALE AS SHOWN 圖號 SHEET SF-12

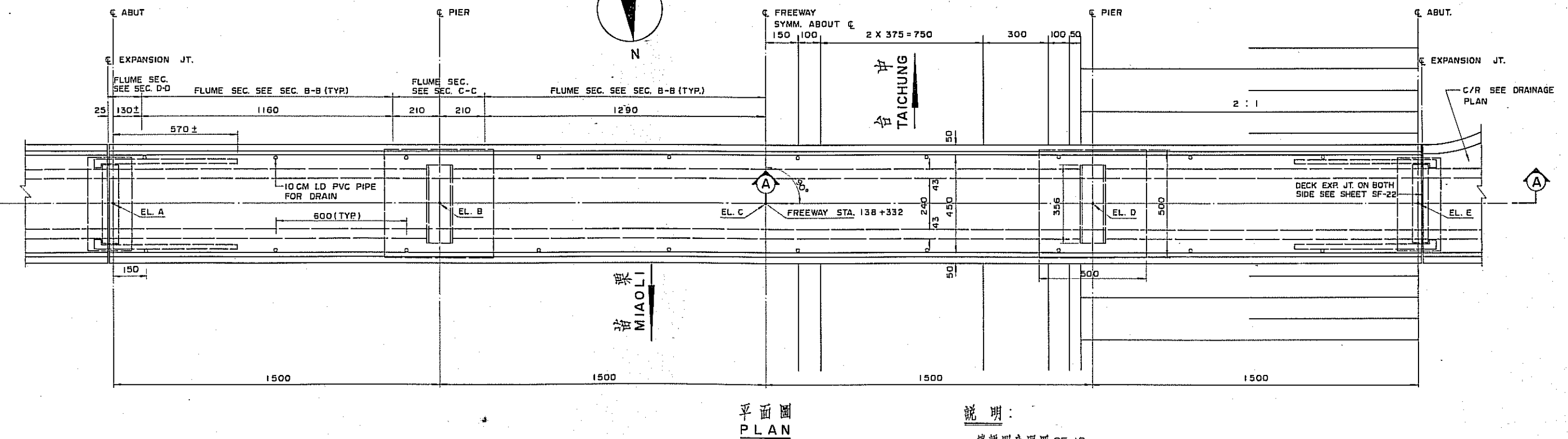
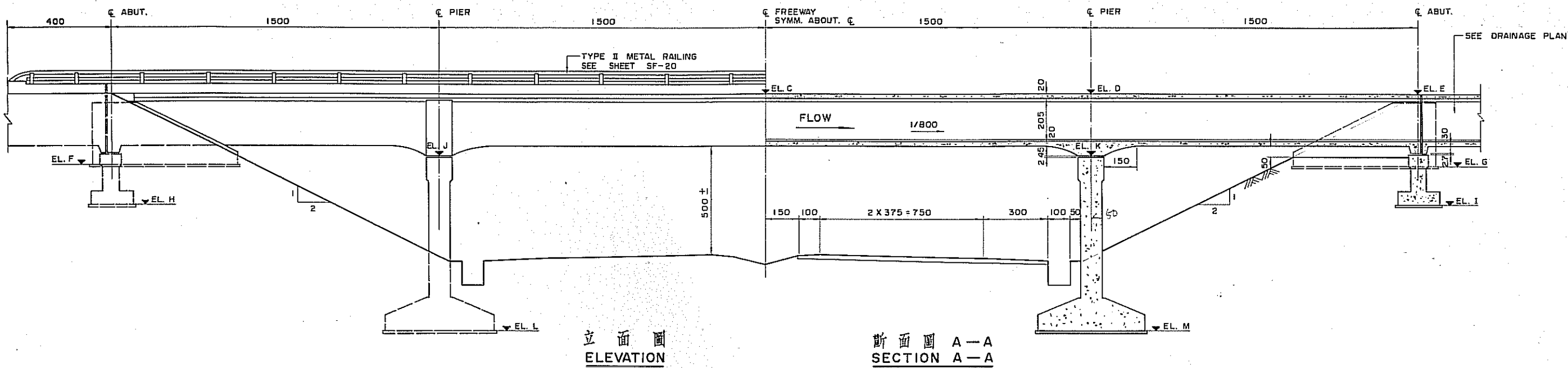

說 明：
詳說明參照圖 SF-18。

NOTE:
FOR GENERAL NOTES SEE SHEET SF-18.

STATION FREEWAY	EL. ON TOP OF TOP SLAB (ALONG FLUME)					ELEVATIONS								REMARK
	A	B	C	D	E	F	G	H	I	J	K	L	M	
138 + 332	196.176	196.157	196.138	196.119	196.100	192.370	192.300	191.026	190.950	193.257	193.219	185.257	185.219	

PROJECT 60

交通部台灣區高速公路工程局
TAIWAN AREA FREEWAY CONSTRUCTION BUREAU
中華民國 REPUBLIC OF CHINA

南北高速公路 NORTH-SOUTH FREEWAY
苗栗台中段 MIAOLI-TAICHUNG SECTION

渡槽 (138+332) FLUME
總平面圖 GENERAL PLAN

中華顧問工程司 CHINA ENGINEERING CONSULTANTS, INC.
DATE AUG. '74 SCALE 1:100 SHEET SF-14

修正 項目	REVISIONS ITEM	日期 DATE

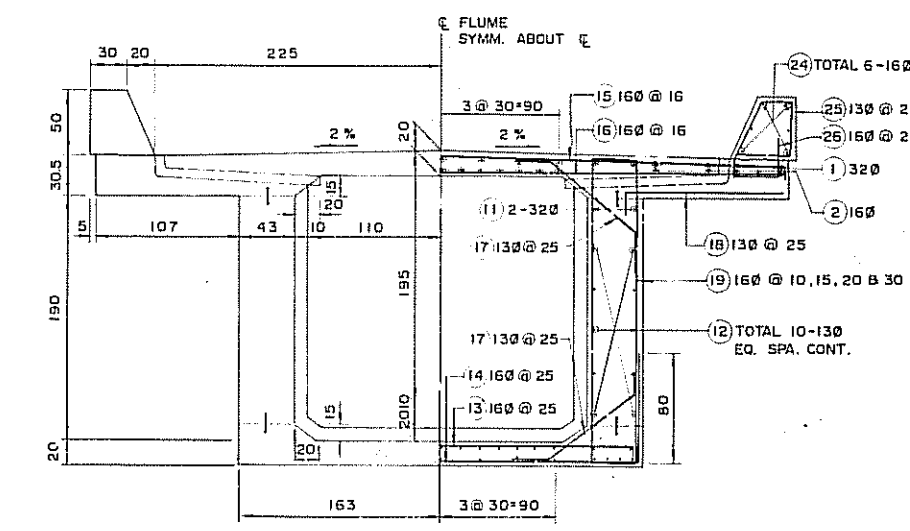
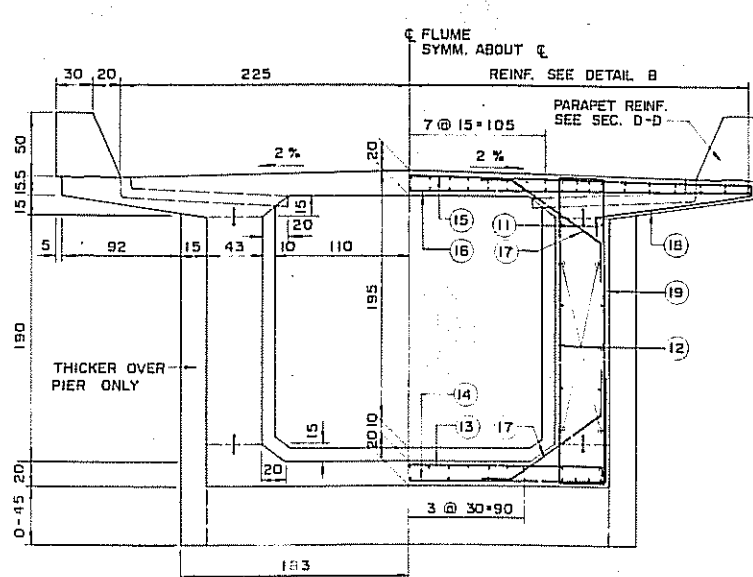
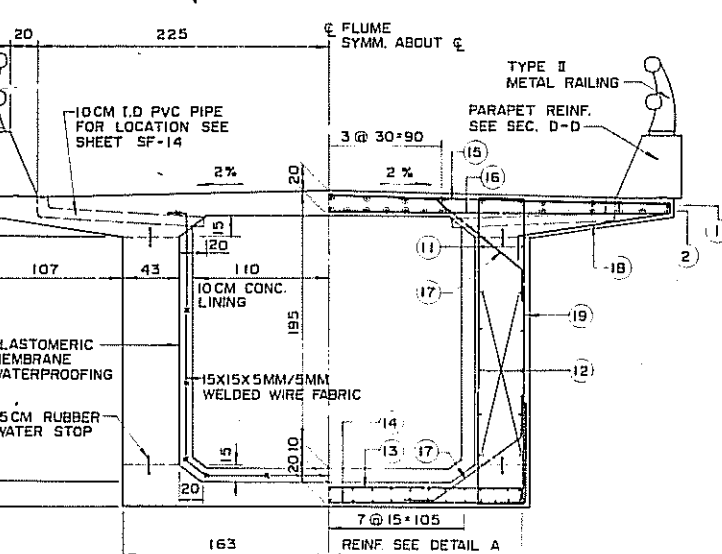
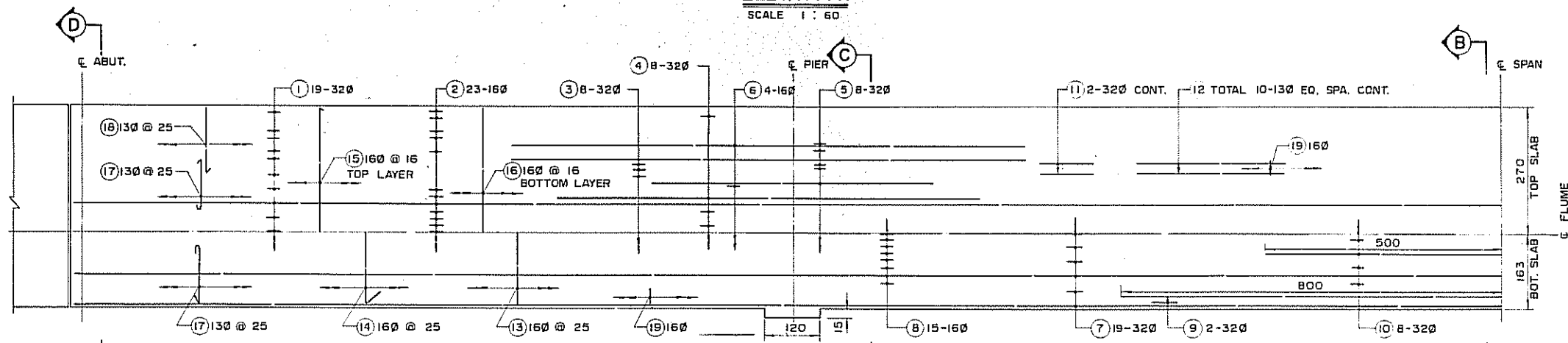
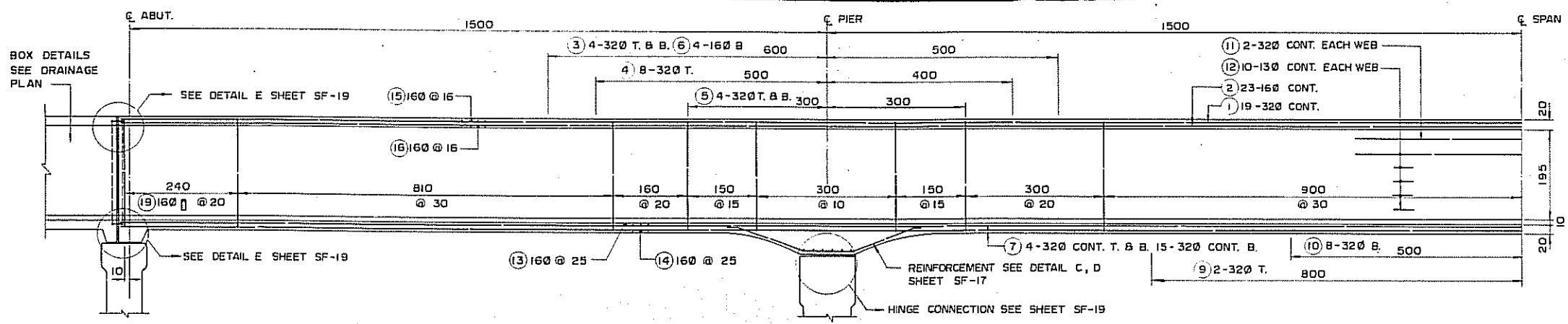

詳 圖 A
DETAIL A

詳 圖 B
DETAIL B

鋼 筋 表
LIST OF REINFORCING STEELS

SHAPE	NOMINAL DIA. (MM)	REMARK
①	32 Ø	CONT.
②	16 Ø	CONT.
③	32 Ø	L = 11M
④	32 Ø	L = 9M
⑤	32 Ø	L = 6M
⑥	16 Ø	L = 11M
⑦	32 Ø	CONT.
⑧	16 Ø	CONT. @ 25
⑨	32 Ø	L = 16M
⑩	32 Ø	L = 10M
⑪	32 Ø	CONT.
⑫	13 Ø	CONT.
⑬	16 Ø	@ 25
⑭	16 Ø	@ 25
⑮	16 Ø	@ 16
⑯	16 Ø	@ 16
⑰	13 Ø	@ 25
⑱	13 Ø	@ 25
⑲	16 Ø	
⑳	16 Ø	SEE SHEET SF-17
㉑	16 Ø	
㉒	13 Ø	
㉓	13 Ø	
㉔	16 Ø	
㉕	13 Ø	@ 25
㉖	16 Ø	@ 25

說 明：
總說明參照圖 SF-18。

NOTE：
FOR GENERAL NOTES SEE SHEET SF-18.

PROJECT 60

交通部台灣區高速公路工程局
TAIWAN AREA FREEWAY CONSTRUCTION BUREAU
中華民國
REPUBLIC OF CHINA

南北高速公路
苗栗台中段
NORTH-SOUTH FREEWAY
MIAOLI-TAICHUNG SECTION

渡槽 (138+332)
上層結構鋼筋詳圖
FLUME
SUPERSTR. REINF. DETAILS

中華顧問工程司
CHINA ENGINEERING CONSULTANTS, INC.

日期 DATE AUG. '74 比例 SCALE AS SHOWN 圖號 SHEET SF-15

修正 REVISIONS	項目 ITEM	日期 DATE

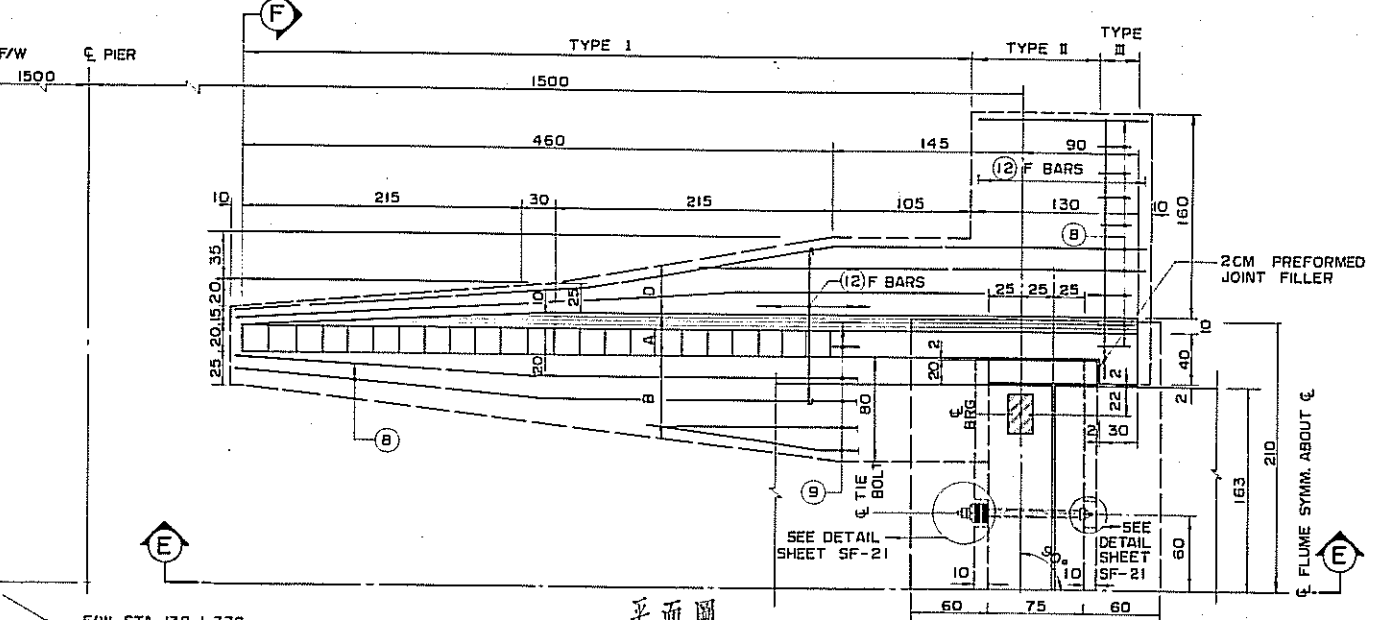

平面圖
PLAN

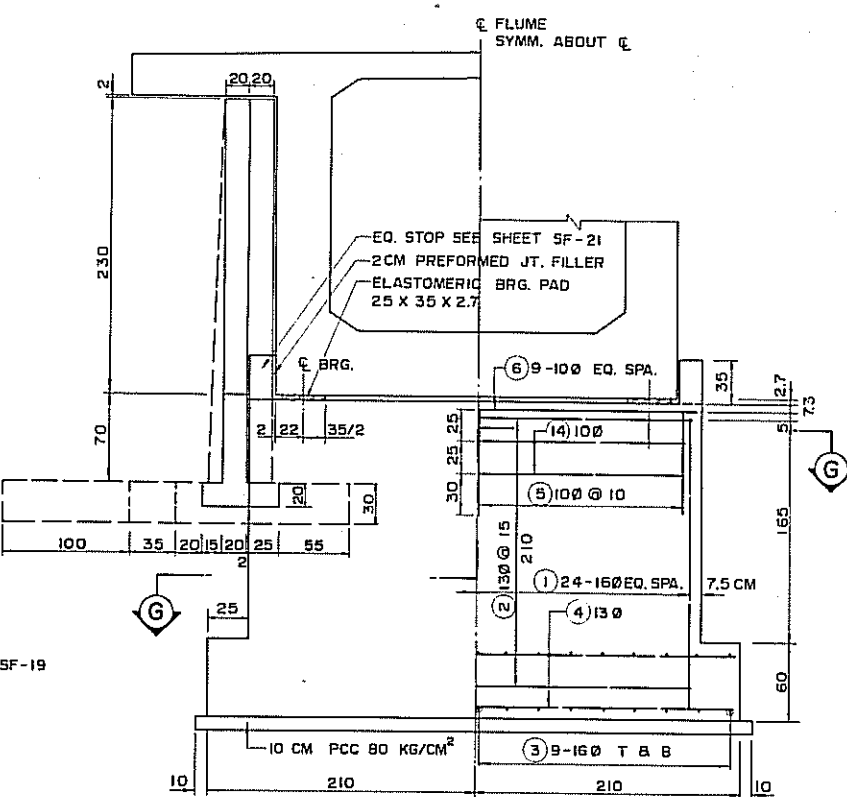

斷面圖 F-F
SECTION F-F

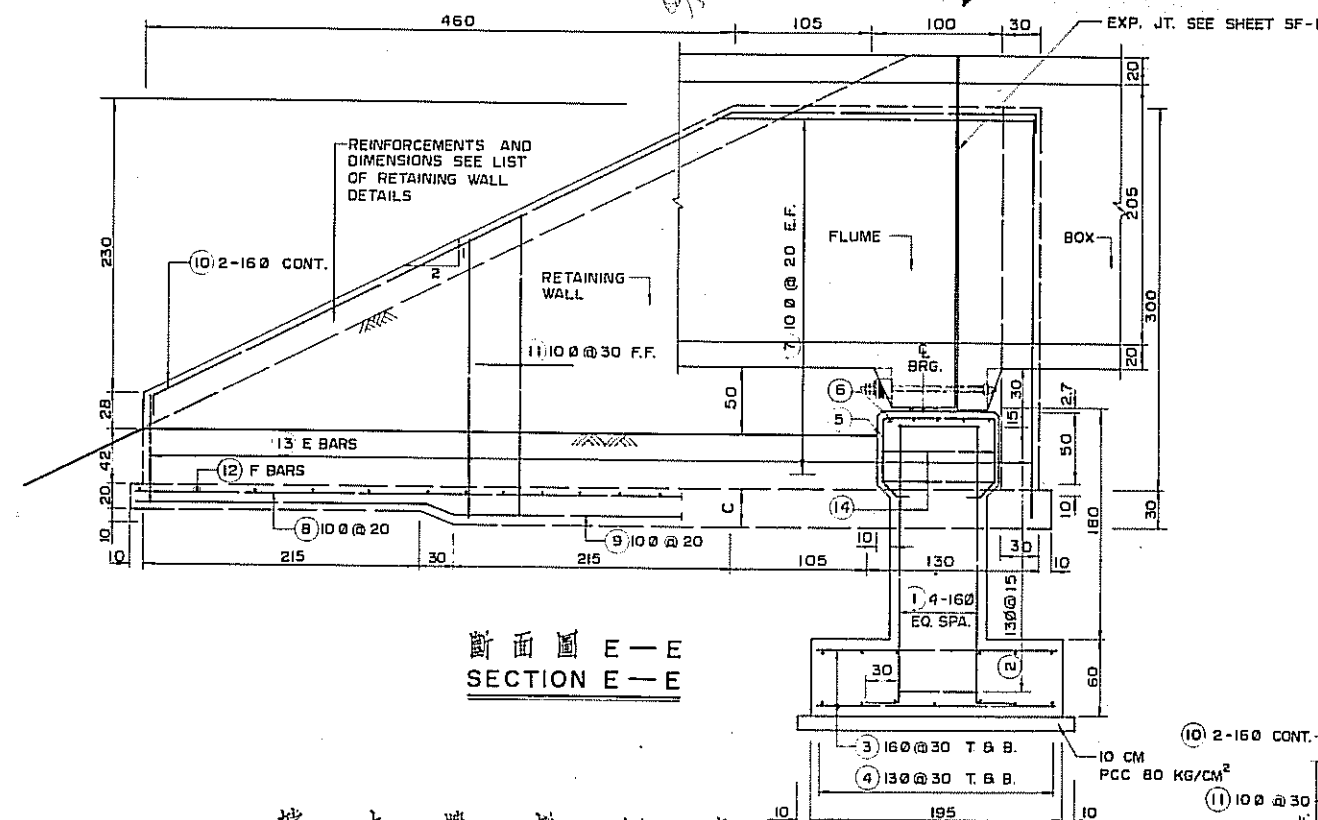

斷面圖 E-E
SECTION E-E

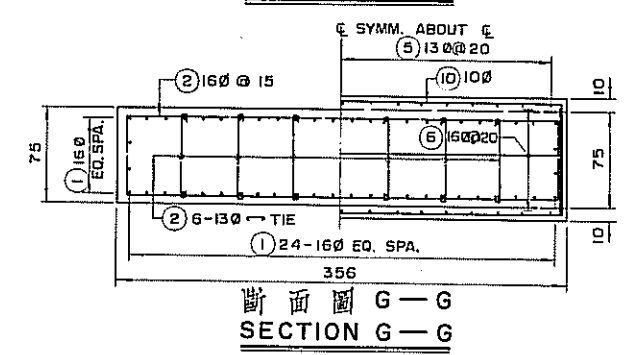

斷面圖 G-G
SECTION G-G

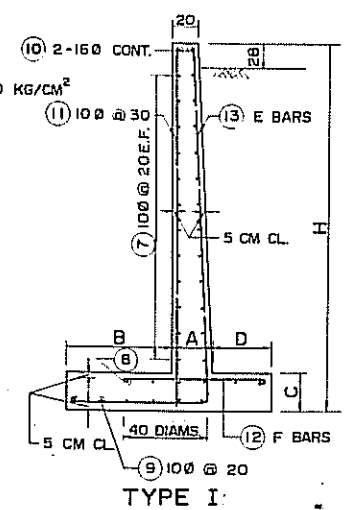

擋土牆斷面圖
SECTIONS OF RETAINING WALL

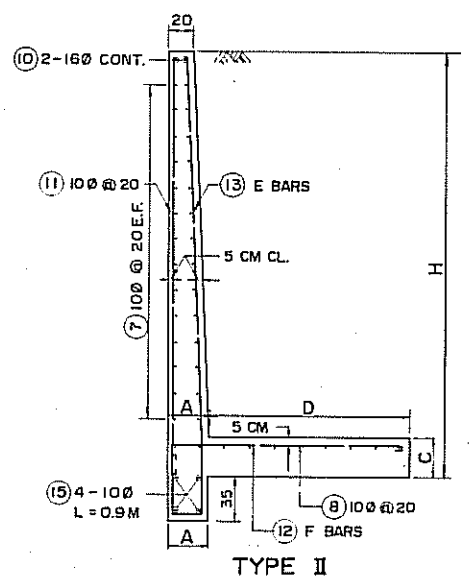

鋼筋表
LIST OF REINFORCING STEELS

SHAPE	NOMINAL DIA. (MM)	REMARK
①	16 @	
②	13 @	@ 15
③	16 @	@ 30
④	13 @	@ 30
⑤	13 @	@ 20
⑥	16 @	@ 20
⑦	10 @	@ 20
⑧	10 @	@ 20
⑨	10 @	@ 20
⑩	16 @	
⑪	10 @	@ 30
⑫	13 @ & 16 @	SEE LIST OF RETAINING WALL DETAILS
⑬	13 @ & 16 @	DETAILS
⑭	10 @	
⑮	10 @	L = 90 CM

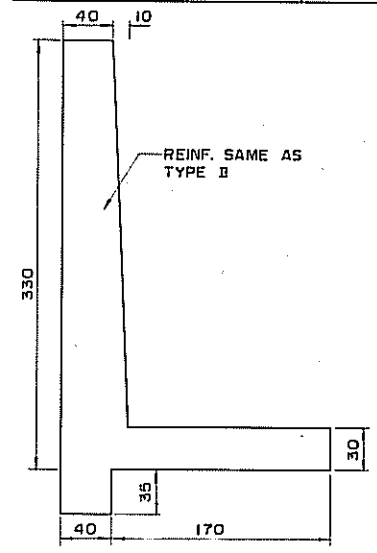

說明:

1. 說明參照圖 SF-18.
 2. 設計最大基礎壓力 21 噸/平方公尺.
- NOTES:
1. FOR GENERAL NOTES SEE SHEET SF-18.
 2. MAX. DESIGN FOUNDATION PRESSURE 21 T/M².

擋土牆詳細表
LIST OF RETAINING WALL DETAILS

RANGE CM	215	30	215	105	100	30
TYPE	I					
H CM	90 - 1975		197.5 - 330		330	330
A CM	20 - 30		30	30	30	50
B CM	25 - 80					
C CM	20	20 30	30	30	30	30
D CM	15 - 25		25 - 60		60	160
E - BARS	13 @ 30		16 @ 35 - @ 25		16 @ 25	16 @ 25
F - BARS	13 @ 45		13 @ 30		13 @ 30	16 @ 20

PROJECT 60

交通部台灣區高速公路工程局
TAIWAN AREA FREEWAY CONSTRUCTION BUREAU
中華民國
中華人民共和國

南北高速公路 NORTH-SOUTH FREEWAY
苗栗台中段 MIAOLI-TAICHUNG SECTION

渡槽(138+332) FLUME
橋台 ABUTMENT

中華顧問工程司 CHINA ENGINEERING CONSULTANTS, INC.

日期 DATE AUG. '74 比例 SCALE 1:30 圖號 SHEET SF-16

修正 REVISIONS	項目 ITEM	日期 DATE

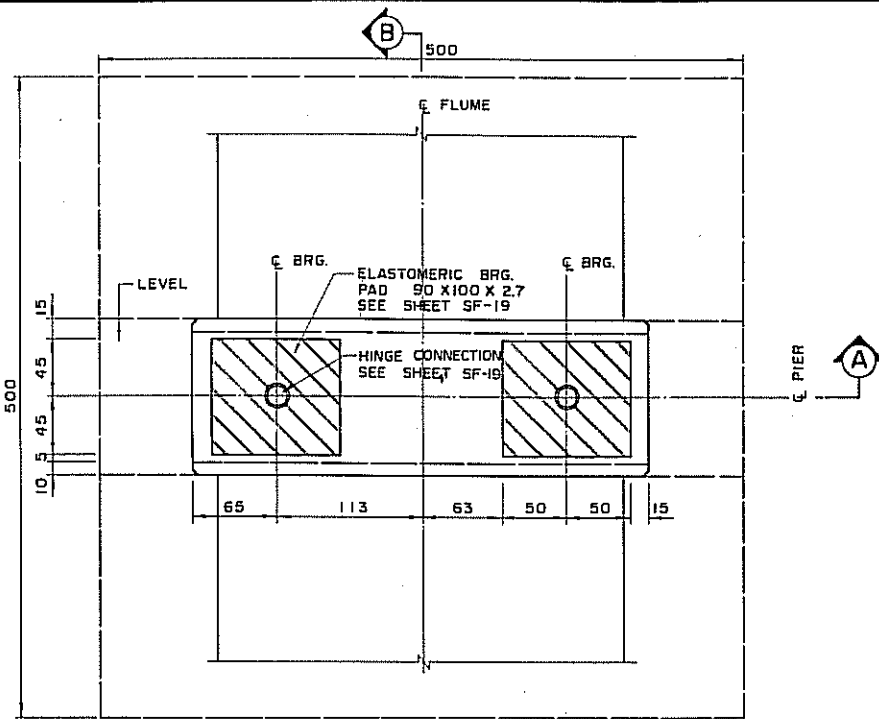

平面圖
PLAN

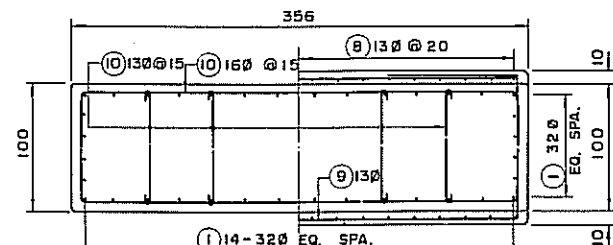

斷面圖 C-C
SECTION C-C

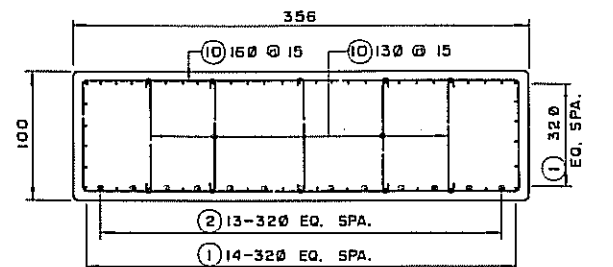

斷面圖 D-D
SECTION D-D

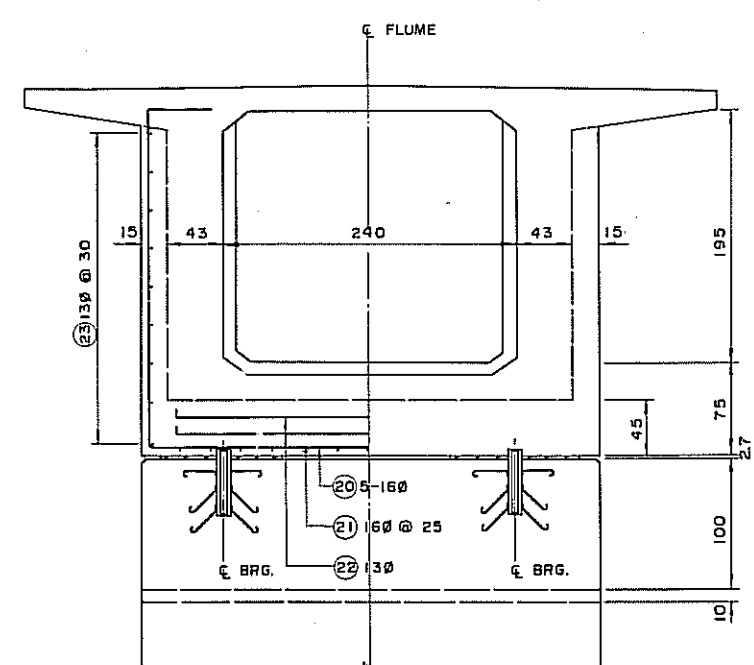

詳圖 C
DETAIL C

鋼筋表
LIST OF REINFORCING STEELS

SHAPE	NOMINAL DIA. (MM)	REMARK
(1)	320	
(2)	320	
(3)	250	@ 15
(4)	250	@ 30
(5)	160	@ 25
(6)	130	@ 30
(7)	130	
(8)	130	@ 20
(9)	130	
(10)	130 B 160	130 I 160
(20)	160	ADD. BARS
(21)	160	ADD. BARS
(22)	130	ADD. BARS
(23)	130	ADD. BARS

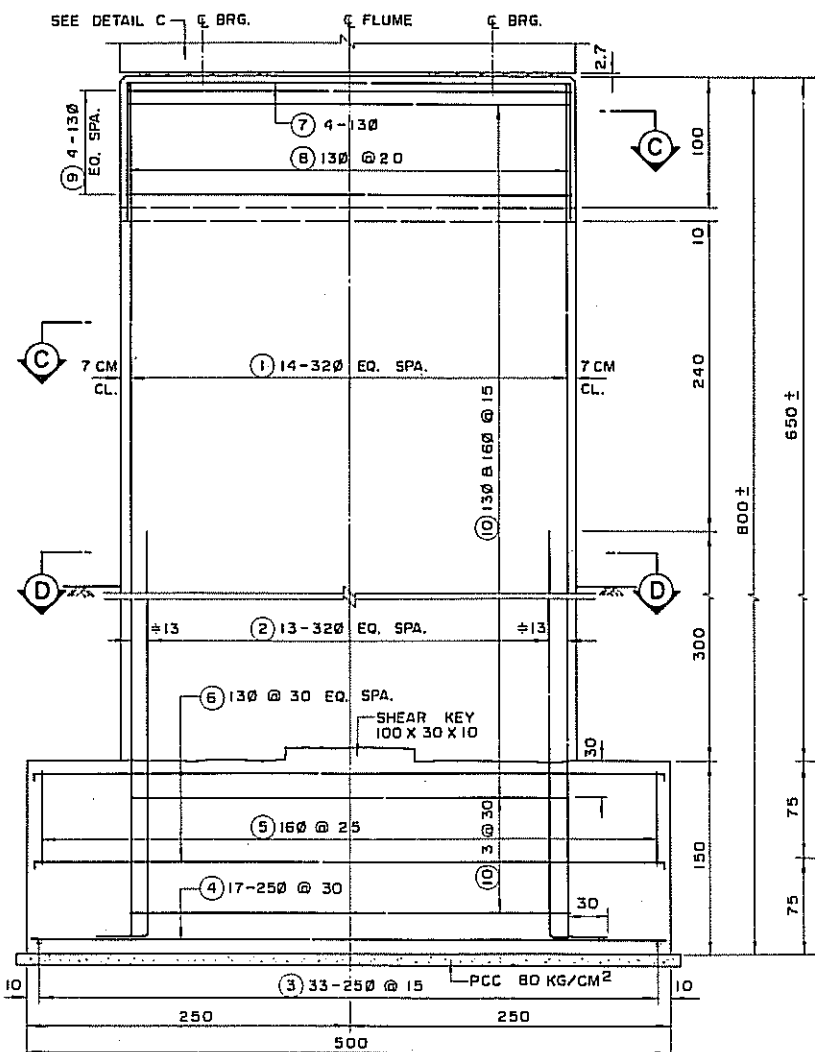

斷面圖 A-A
SECTION A-A

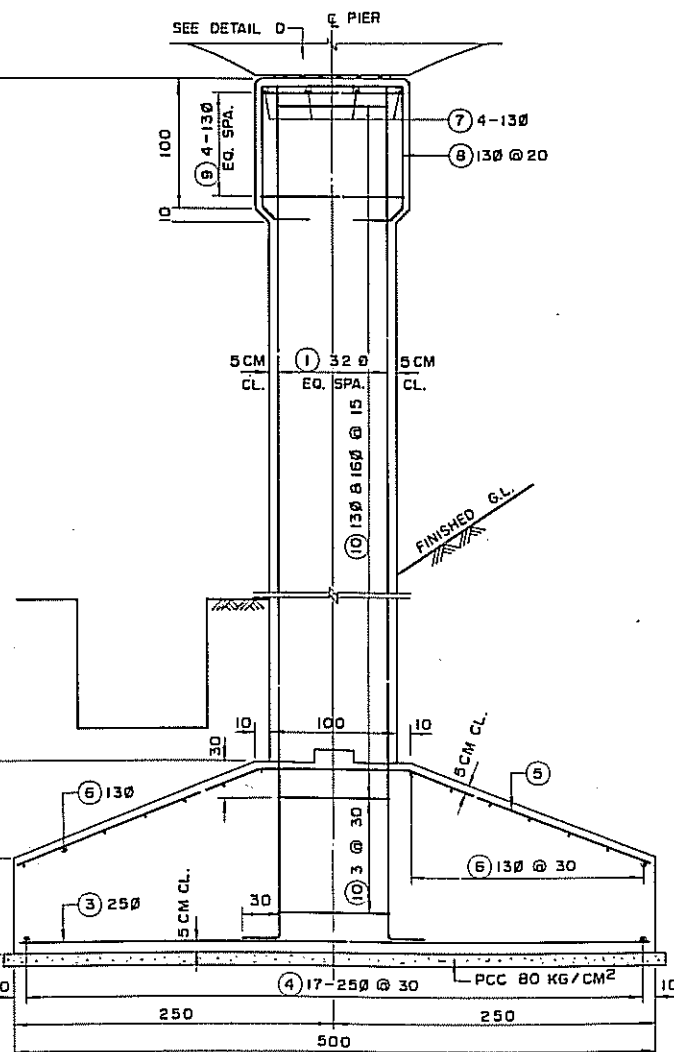

斷面圖 B-B
SECTION B-B

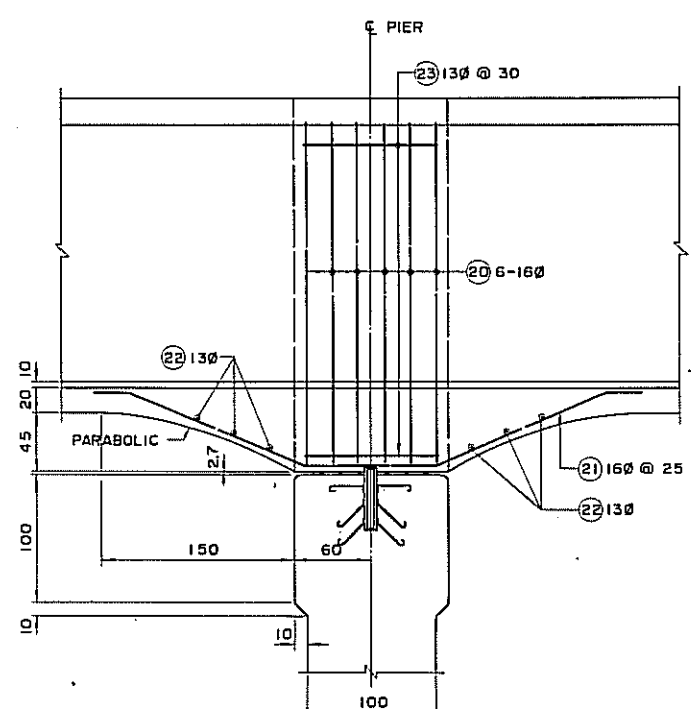

詳圖 D
DETAIL D

說明:

1. 總說明參照圖 SF-18.
2. 設計最大基礎壓力 28 噸 / 平方公尺.

NOTES

1. FOR GENERAL NOTES SEE SHEET SF-18.
2. MAX. DESIGN FOUNDATION PRESSURE 28 T/M².

修正	REVISIONS	項目	ITEM	日期	DATE

PROJECT 60
交通部台灣區高速公路工程局
TAIWAN AREA FREEWAY CONSTRUCTION BUREAU
中華民國
REPUBLIC OF CHINA
南北高速公路
NORTH-SOUTH FREEWAY
苗栗台中段
MIAOLI-TAICHUNG SECTION
渡槽 (138+332)
FLUME
橋墩
PIER
中華顧問工程司
CHINA ENGINEERING CONSULTANTS, INC.
日期 DATE AUG. '74 比例 SCALE 1:30 圖號 SHEET SF-17

總說明

設計規範：美國公路協會 1969 年之“公路橋樑標準規範”及 1971 年“中興規範”。

設計活載重：H15 及滿水重。

地震力：(靜載重 + 滿水重) × 15%

設計應力：

- A. 無筋混凝土(基礎下)： $f_c = 80 \frac{kg}{cm^2}$
- B. 鋼筋混凝土：
下部結構、引道版及護牆 $f_c = 240 \frac{kg}{cm^2}$
 $f_c = 96 \frac{kg}{cm^2}$
- C. 預力混凝土：見預力混凝土箱樑說明。
- D. 鋼筋： $f_s = 1400 \frac{kg}{cm^2}$
- E. 預力鋼筋：見工程局“標準規範”。

5. 各項尺寸除另有註明者外，單位均以公分(CM)計。

6. 鋼筋均採用竹節鋼筋。

7. 鋼筋之彎製續接及埋置，除另行註明者外，均按圖 SF-21 標準詳細圖辦理。

8. 鋼筋之淨保護層除另有註明者外，依下列規定：

頂版及底版底	2.5 公分
樑腹	4 公分
護牆	4 公分
底版頂	2.5 公分
下部結構及其他	5 公分

9. 混凝土外露之稜線除另規定外，均須設 2 公分之稜角。

10. 簡寫字表示如下：

F.F. — 前面， R.F. — 後面， E.F. — 每面，
BRG. — 支承， EQ. SPA. — 等間距， EQ. — 地震。

1. 橋面曲線變化之各相關尺寸及高度，須由承包商詳細計算繪圖並經工程師審核後方可施工。

2. 倘基礎之容許承載力小於設計圖所註明之設計最大基礎壓力，則基礎之深度或大小，應受工地工程師之指示變更之。

3. 承包商應查對設計圖所註所有各部尺寸及高度，如發現任何不符之處，應於施工前通知工程師修正。

4. 鷹架應妥為設計，以防止因過大或不均勻沉陷而引起混凝土破裂。

5. 鄰近橋墩處之鷹架，應設計使之能將所有垂直荷重直接傳於橋墩。

6. 施預力完成後，鷹架應由樑中間向橋墩方向逐步完全拆除。

17. 上部結構模板，應參考各橋鋼筋佈置詳圖上所示之撓度示意圖調整其高度，曲線詳細計算應由承包商提交工程師審核後方可施工。

GENERAL NOTES

- DESIGN SPECIFICATIONS: AASHO "STANDARD SPECIFICATIONS FOR HIGHWAY BRIDGES" 1969 AND "INTERIM SPECIFICATIONS" 1971
- 2. DESIGN LIVE LOAD: H-15 AND FULL DEPTH WATER LOAD.
- 3. EARTHQUAKE FORCE (THE DEAD LOAD + FULL DEPTH WATER LOAD) 15%.
- 4. DESIGN STRESSES:
 - A. PLAIN CONCRETE (UNDER FOUNDATION) $f_c = 80 \text{ KG/CM}^2$
 - B. REINFORCED CONCRETE: SUBSTRUCTURES, APPROACH SLAB, AND PARAPET. $f_c = 240 \text{ KG/CM}^2$
 $f_c = 96 \text{ KG/CM}^2$
 - C. PRESTRESSED CONCRETE: SEE NOTES FOR P.C. BOX GIRDER.
 - D. REINFORCING STEEL BARS. $f_s = 1400 \text{ KG/CM}^2$
 - E. PRESTRESSING STEEL: SEE "STANDARD SPECIFICATIONS" TAFCB.
- 5. ALL DIMENSIONS ARE IN CM UNLESS OTHERWISE NOTED.
- 6. ALL REINFORCING STEELS SHALL BE DEFORMED BARS
- 7. FOR REINFORCING BAR BENDING, SPLICE AND EMBEDMENT DETAILS SEE STANDARD SHEET SF-21 UNLESS OTHERWISE NOTED.
- 8. MIN. CLEAR COVER OF ANY REINFORCING BAR, UNLESS OTHERWISE SPECIFIED SHALL BE AS FOLLOWS:

BOTTOM OF TOP & BOTTOM SLAB	2.5 CM
WEB	4 CM
PARAPET	4 CM
TOP OF BOTTOM SLAB	2.5 CM
SUBSTRUCTURE & OTHERS	5 CM
- 9. ALL EXPOSED EDGES OF CONCRETE SHALL BE CHAMFERED 2 CM UNLESS OTHERWISE NOTED.
- 10. ABBREVIATIONS OF WORDS ARE SHOWN AS FOLLOWS:

F.F. — FRONT FACE,	E.F. — EACH FACE,
R.F. — REAR FACE,	BRG. — BEARING,
EQ. SPA. — EQUAL SPACE, EQ. — EARTHQUAKE	
- 11. GEOMETRY OF CURVED DECK SHALL BE CALCULATED BY THE CONTRACTOR AND SUBMITTED TO THE ENGINEER FOR APPROVAL
- 12. IN CASE THE SOIL ALLOWABLE BEARING CAPACITY IS LESS THAN MAX. DESIGN FOUNDATION PRESSURE SPECIFIED IN THE DESIGN DRAWING, THE DEPTH OR DIMENSIONS OF FOOTING SHALL BE CHANGED BY THE SITE ENGINEER.
- 13. THE CONTRACTOR SHALL VERIFY ALL DIMENSIONS AND ELEVATIONS SHOWN ON THE PLANS AND SHALL NOTIFY THE ENGINEER OF ANY AND ALL DISCREPANCIES PRIOR TO THE BEGINNING OF THE WORK.
- 14. THE FALSEWORK SHALL BE SUITABLY DESIGNED TO PREVENT LARGE OR UNEQUAL SETTLEMENT WHICH WOULD CAUSE CRACKING OF THE CONCRETE.
- 15. THE FALSEWORK ADJACENT TO THE PIERS SHALL BE DESIGNED TO TRANSMIT THE FULL VERTICAL LOADS DIRECTLY TO THE PIERS.
- 16. UPON COMPLETION OF PRESTRESSING, THE FALSEWORK SHALL BE FULLY RELEASED GRADUALLY AND UNIFORMLY FROM MID-SPAN TOWARDS THE PIER.
- 17. FORM FOR THE SUPERSTRUCTURE SHALL BE ADJUSTED IN ELEVATION TO PRODUCE THE REQUIRED INITIAL NEGATIVE CAMBER AS SHOWN ON THE SHEET OF TENDON LAYOUT DETAILS FOR EACH BRIDGE. THE CONTRACTOR SHALL SUBMIT THE EXACT CALCULATION OF NEGATIVE CAMBER TO THE ENGINEER FOR APPROVAL BEFORE WORK BEGINNING.

預力混凝土箱樑之說明

- 1. 所用後拉工法應經工程師之核可。
- 2. 後拉法應採用經許可之錨固設施。
- 3. 後拉法預力混凝土之鋼筋應為高拉力、冷拉、經消力熱處理者，其保證最小極限強度須符合工程局“標準規範”之有關規定。
- 4. 鋼筋應置於下漏管之柔性金屬套管內，端部應設有孔道以為灌漿通入套管之需，所有鋼筋應為整支連續，不得續接或加用連接器。
- 5. P_f = 在箱樑中央斷面之有效預力(預力箱樑所有損失發生後所保留之預力)。
 P_i = 在箱樑中央斷面之起始預力。
- 6. 承包商在施工前應將鋼筋及錨固之排列細節、伸長度及千斤頂所施預力之計算，提送工程師核可。
- 7. 計算後拉預力樑在端點千斤頂所施預力應包括千斤頂所引起之損失、摩擦損失及彈性縮短損失，並依下述資料計算之：

曲線摩擦係數	$\mu = 0.25$
波浪式摩擦係數	$k = 0.0049/M$
彈性模數比	$n = 6$
- 8. 上部結構箱樑應從兩端同時施預力。
- 9. 所需混凝土抗壓強度除註明者外應如下：

28 天之強度	$f'_c = 350 \text{ 公斤/平方公分}$
施預力時之強度	$f'_{ci} = 280 \text{ 公斤/平方公分}$
- 10. 每一套管於鄰近橋墩處，在樑之上端各置一通氣孔，如鋼筋佈置詳圖所示。
- 11. 端部與樑端間之凹處，用混凝土填塞。
- 12. 箱樑混凝土之灌注可分為底版、梁腹、頂版三階段，版與梁腹接觸面應加設剪力棒或由人工處理成粗糙面。

NOTES FOR PRESTRESSED CONCRETE BOX GIRDER

- 1. THE POST-TENSIONING SYSTEM TO BE USED SHALL BE APPROVED BY THE ENGINEER.
- 2. AN APPROVED METHOD OF POSITIVE END ANCHORAGE SHALL BE PROVIDED FOR POST-TENSIONING.
- 3. TENDONS FOR POST-TENSIONING PRESTRESSED CONCRETE SHALL CONSIST OF HIGH TENSILE, COLD DRAWN, STRESS RELIEVED WIRE HAVING A GUARANTEED MINIMUM ULTIMATE STRENGTH AS SPECIFIED IN "STANDARD SPECIFICATIONS" OF TAFCB.
- 4. TENDONS SHALL BE ENCLOSED IN MORTAR-TIGHT FLEXIBLE METAL CONDUITS. ANCHORAGE SHALL PROVIDE FOR GROUT PASSAGE THROUGH THE CONDUIT. ALL TENDONS SHALL BE FURNISHED IN CONTINUOUS LENGTHS WITHOUT SPLICES OR COUPLINGS.
- 5. P_f = EFFECTIVE PRESTRESSING FORCE (THE FORCE OF P.C. BOX GIRDER REMAINING AFTER ALL LOSSES HAVE OCCURRED).
 P_i = INITIAL PRESTRESSING FORCE AT MID SECTION OF BOX GIRDER.
- 6. THE CONTRACTOR SHALL SUBMIT TENDON AND ANCHORAGE ARRANGEMENT DETAILS, ELONGATION, JACKING CALCULATION TO THE ENGINEER FOR APPROVAL BEFORE WORK BEGINNING
- 7. THE CALCULATION OF JACKING FORCE AT THE END OF POST-TENSIONING GIRDER SHOULD INCLUDING THE JACKING LOSS, FRICTION LOSS AND ELASTIC SHORTENING LOSS. THE FOLLOWING DATA ARE USED FOR CALCULATION.

CURVATURE FRICTION COEFFICIENT	$\mu = 0.25$
WOBBLE COEFFICIENT	$k = 0.0049/M$
ELASTIC MODULUS RATIO	$n = 6$
- 8. THE SUPERSTRUCTURE OF BOX GIRDER SHALL BE POST-TENSIONED FROM BOTH ENDS SIMULTANEOUSLY.
- 9. REQUIRED COMPRESSIVE STRENGTH SHALL BE AS FOLLOWS, UNLESS OTHERWISE NOTED.

AT 28 DAYS	$f'_c = 350 \text{ KG/CM}^2$
AT TIME OF PRESTRESSING	$f'_{ci} = 280 \text{ KG/CM}^2$
- 10. EACH DUCT SHALL BE PROVIDED WITH 2 INTERMEDIATE VENTS AT THE TOP OF THE GIRDER ONE NEAR EACH PIER AS SHOWN ON THE PLAN OF TENDON LAYOUT DETAILS FOR EACH BRIDGE.
- 11. THE RECESSES FOR THE ANCHORS SHALL BE FILLED WITH PORTLAND CEMENT CONCRETE.
- 12. CONCRETE IN BOX GIRDER MAY BE PLACED IN THREE SEPARATE OPERATIONS, AS BOTTOM SLAB, WEBS, TOP SLAB. THE BOND BETWEEN SLABS AND WEBS SHALL BE POSITIVE AND MECHANICAL AND SECURED BY MEANS OF SHEAR KEY OR ARTIFICIALLY ROUGHENING THE CONCRETE SURFACE OF CONNECTION.

PROJECT 60

修正 REVISIONS	交通部台灣區高速公路工程局 TAIWAN AREA FREEWAY CONSTRUCTION BUREAU 中華民國 REPUBLIC OF CHINA
項目 ITEM 日期 DATE	南北高速公路 NORTH-SOUTH FREEWAY 苗栗台中段 MIAOLI-TAICHUNG SECTION
	渡槽 FLUME
	總說明 GENERAL NOTES
	中華顧問工程司 CHINA ENGINEERING CONSULTANTS, INC.
日期 DATE AUG. '74 比例 SCALE NONE	圖號 SHEET SF-18

鉸接詳圖
HINGE CONNECTION DETAIL

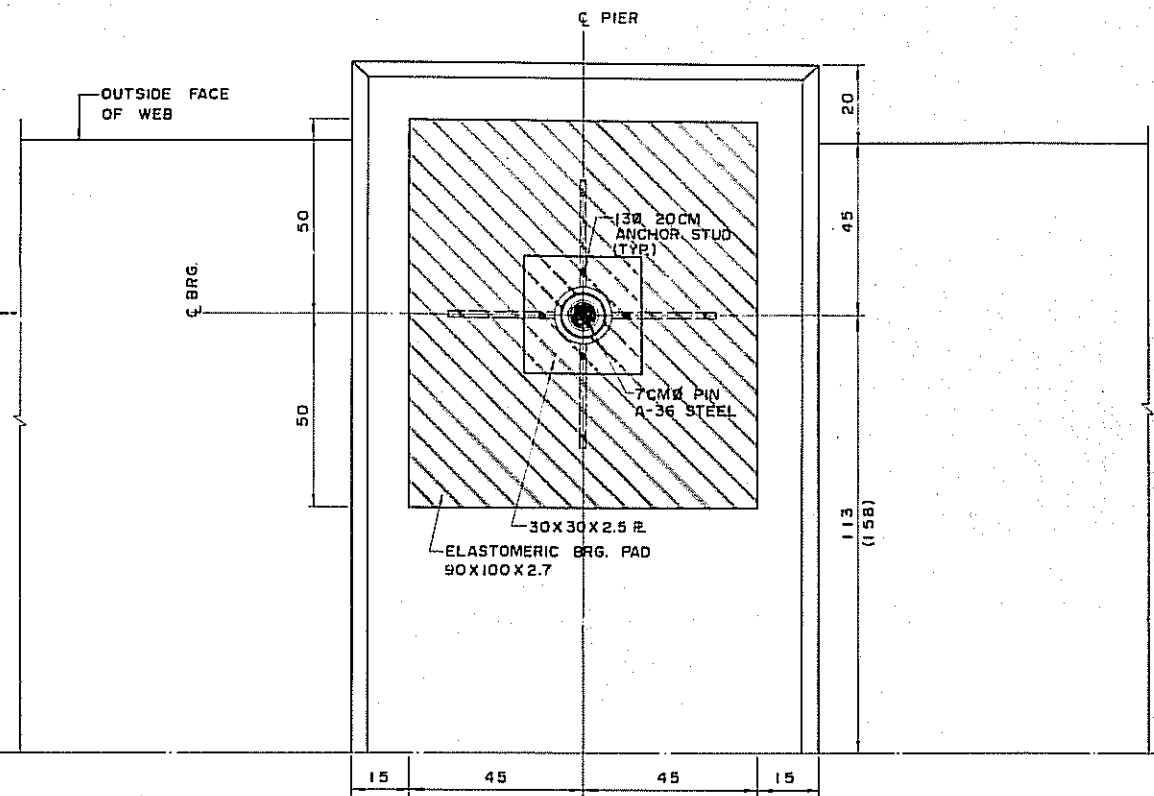

平面圖
PLAN
SCALE 1:10

* NOTE: () INSIDE DIMENSIONS ARE FOR STA. 124+500 ONLY.

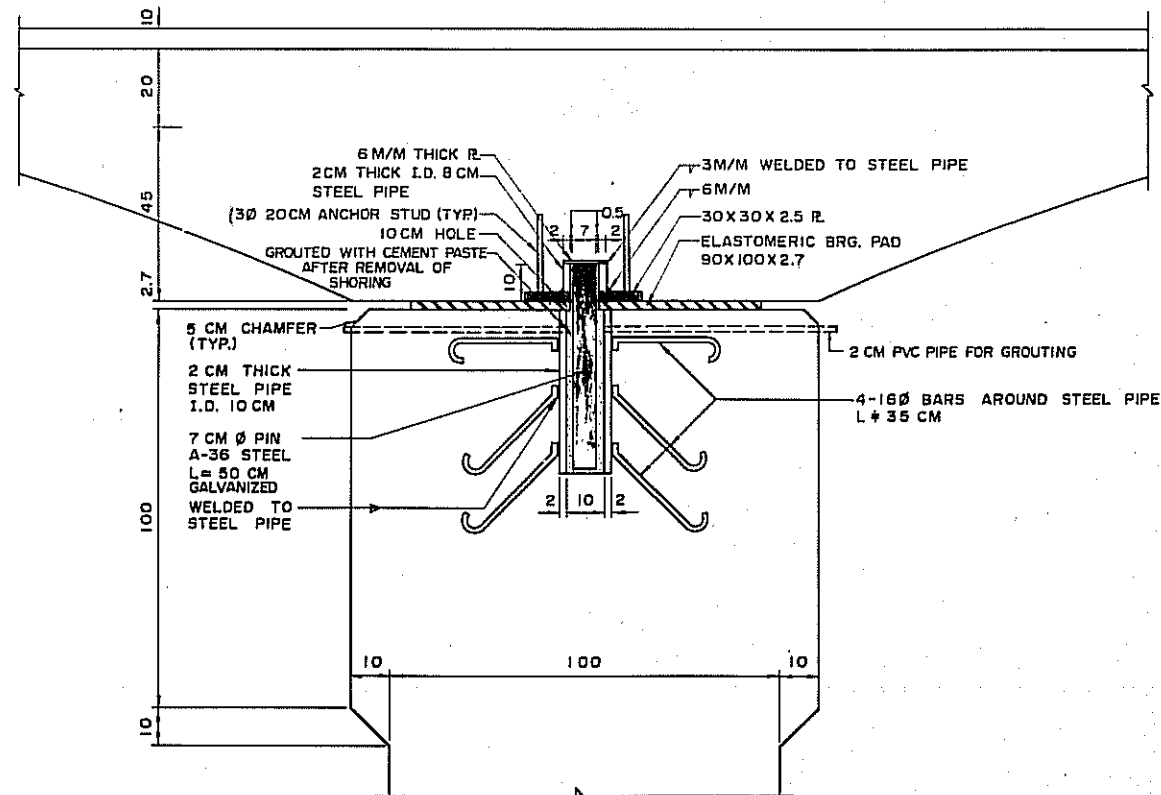

斷面圖 A-A
SECTION A-A
SCALE 1:10

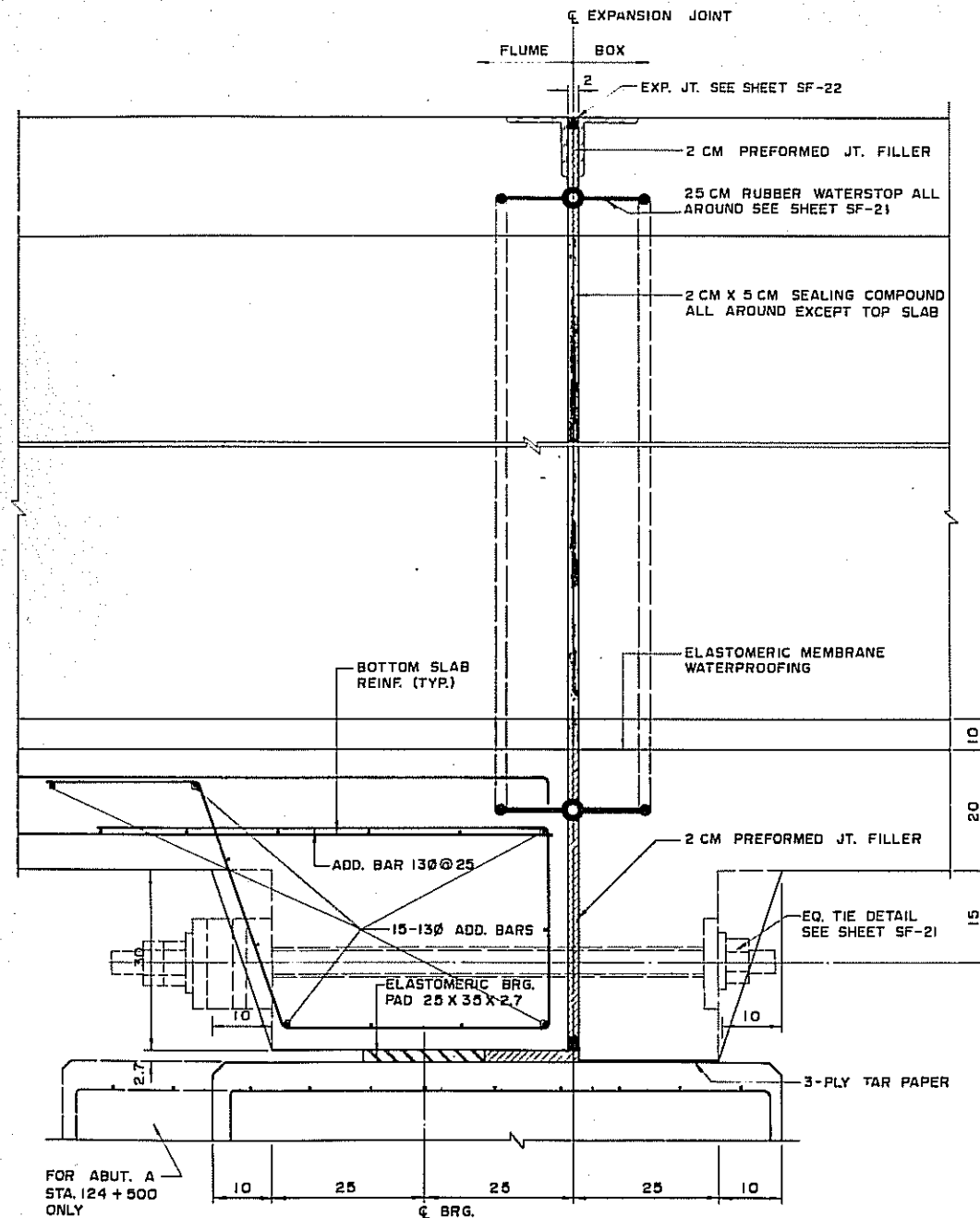

詳圖 E
DETAIL E
SCALE 1:6

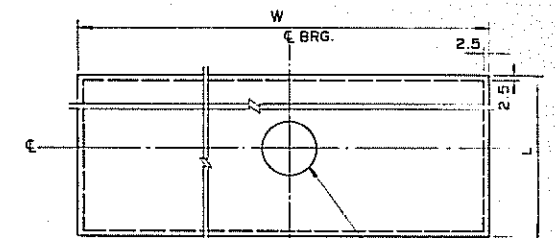

平面圖
PLAN

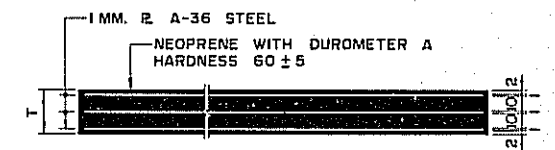

斷面圖
SECTION

詳圖 F
DETAIL F

N.T.S.
(DIMENSIONS ARE IN MM)

合成橡膠支承版詳圖
ELASTOMERIC BRG. PAD DETAILS
DIMENSIONS (L X W X T) ARE IN CM

說明:

總說明參照圖 SF-18。

NOTE:

FOR GENERAL NOTES SEE SHEET SF-18.

PROJECT 60

修正 項目	REVISIONS ITEM	日期 DATE	交通部台灣區高速公路工程局 TAIWAN AREA FREEWAY CONSTRUCTION BUREAU 中華民國 REPUBLIC OF CHINA
			南北高速公路 苗栗台中段 NORTH-SOUTH FREEWAY MIAOLI-TAICHUNG SECTION
			波槽 HINGE CONNECTION & BRG. PAD DETAILS
			中華顧問工程司 CHINA ENGINEERING CONSULTANTS, INC.
			日期 DATE AUG. '74 比例 SCALE AS SHOWN 圖號 SHEET SF-19

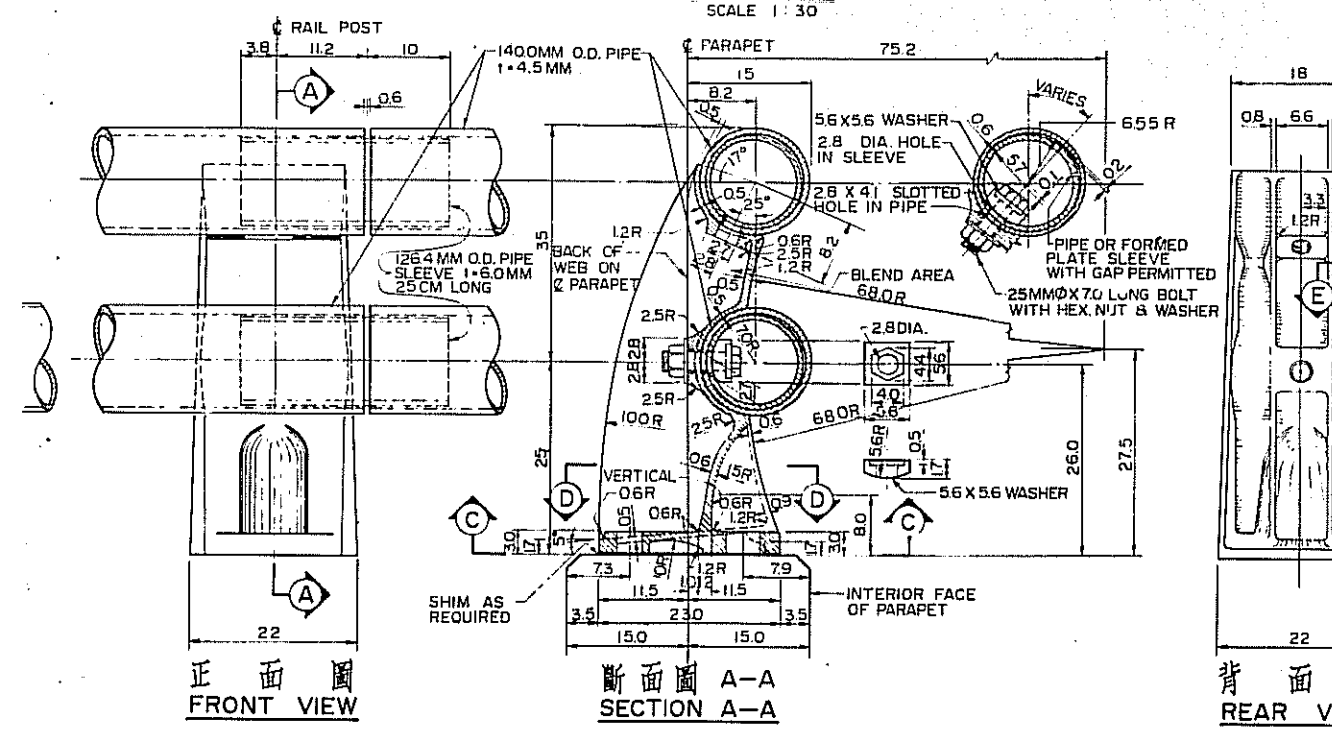
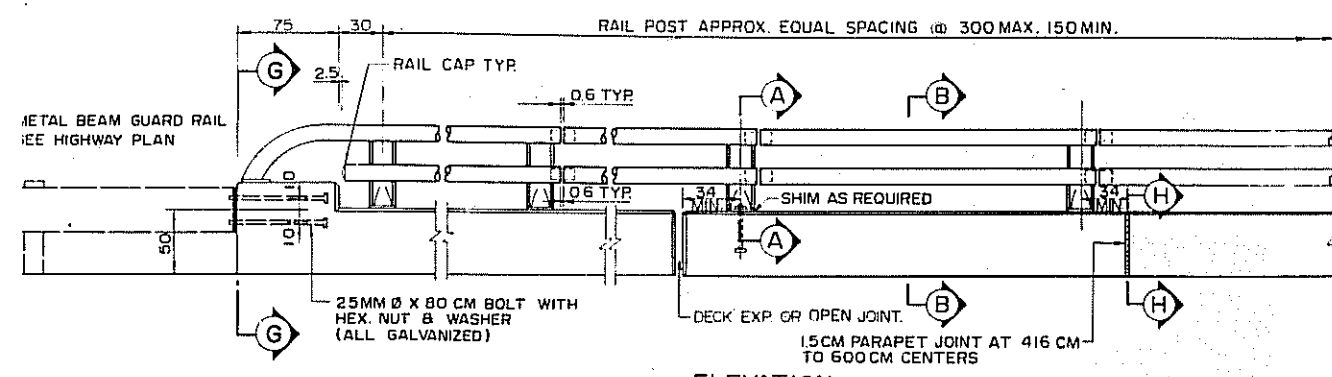
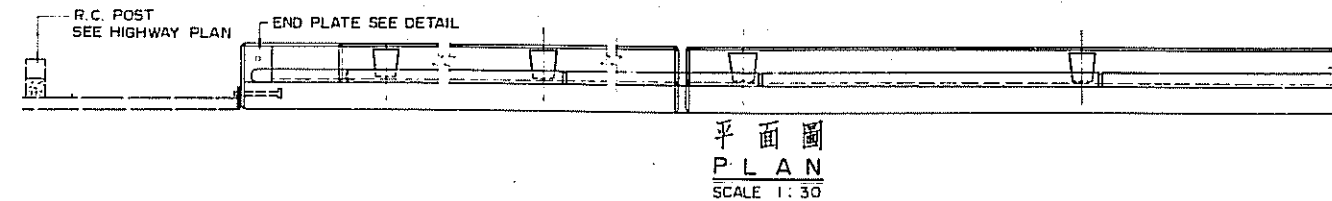

TYPE II RAIL POST ASSEMBLY
SCALE 1:5

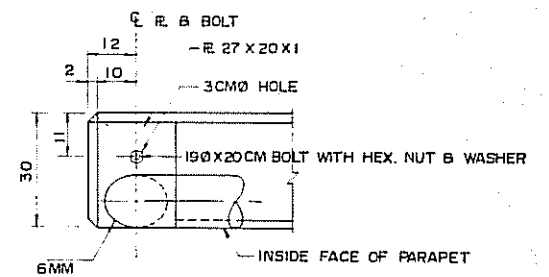
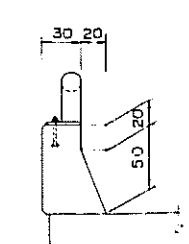
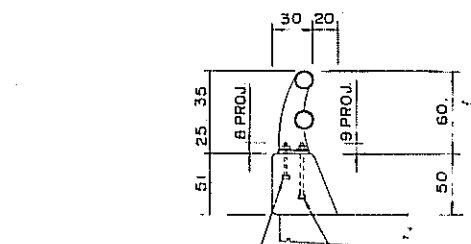

19MMØX20CM BOLT WITH HEX. NUT AND WASHER (ALL GALVANIZED)

32MMØX30CM BOLT WITH HEX. NUT AND WASHER (ALL GALVANIZED)

斷面圖 B-B
SECTION B-B
SCALE 1:30

斷面圖 G-G
SECTION G-G
SCALE 1:30

END PLATE DETAIL
SCALE 1:10

說明:

1. 欄杆材料可採用鋼鐵製或鋁合金製，承包商可自行選定。
2. 若採用鋼鐵欄杆，則於安裝前需將外露面全予鍍鋅。
3. 欄杆裝設於半徑小於45公尺之平面曲線時，欄杆圓管及接頭套管應予準確彎曲，以適合於該曲度。
4. 各項尺寸除另有註明者外，均以公分(CM)計。

NOTES:

1. AT THE OPTION OF THE CONTRACTOR, MATERIAL FOR THE RAILING SHALL BE FERROUS OR ALUMINIOUS.
2. IF FERROUS RAILING IS ADOPTED, ALL EXPOSED PARTS SHALL BE GALVANIZED BEFORE ERECTION.
3. FOR RAILING ON A HORIZONTAL CURVE OF RADIUS LESS THAN 45 METERS, THE PIPE RAIL AND SLEEVES SHALL BE DETAIL D BENT TO FIT THE CURVE.
4. ALL DIMENSIONS ARE IN CM UNLESS OTHERWISE NOTED.

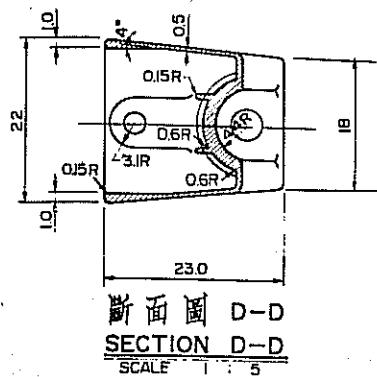
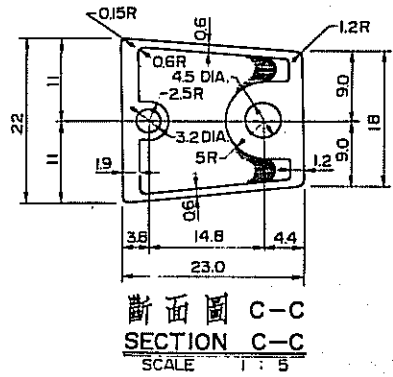
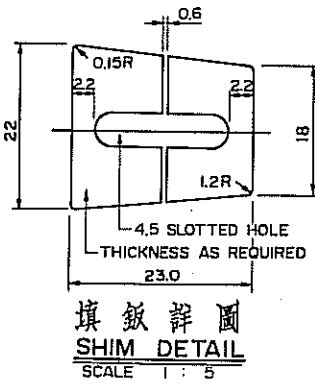
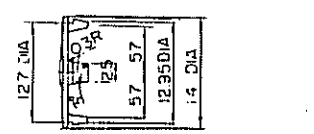
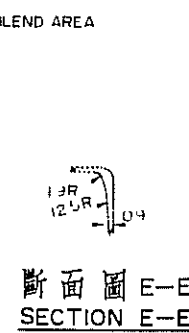
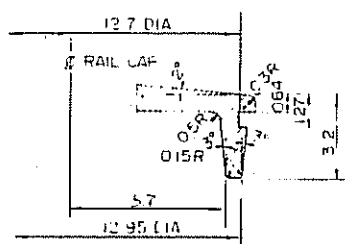

PROJECT 60

修正 REVISIONS	項目 ITEM	日期 DATE	交通部台灣區高速公路工程局 TAIWAN AREA FREEWAY CONSTRUCTION BUREAU 中華民國 REPUBLIC OF CHINA
			南北高速公路 NORTH-SOUTH FREEWAY 苗栗台中段 MIAOLI-TAICHUNG SECTION
			渡槽 FLUME 型式II金屬欄杆詳圖 TYPE II METAL RAILING DETAILS
			中華顧問工程司 CHINA ENGINEERING CONSULTANTS, INC.
			日期 DATE AUG. '74 比例 SCALE AS SHOWN 圖號 APPENDIX SF-20

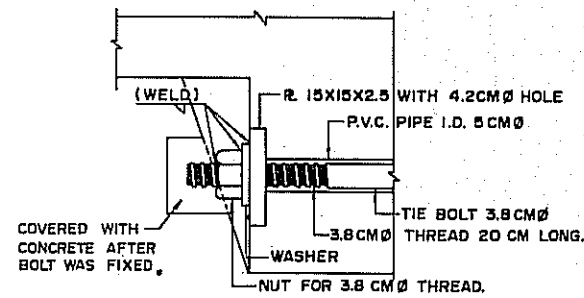
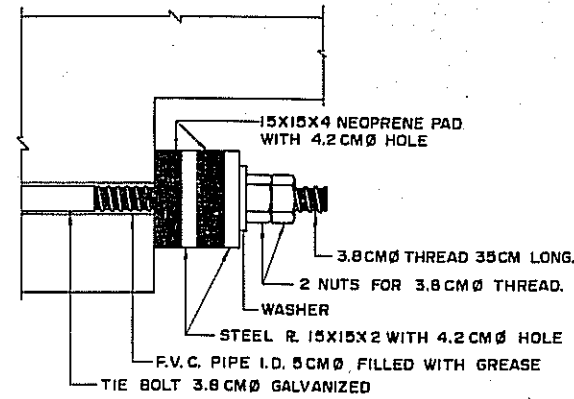

防震拉條詳圖
EARTHQUAKE TIE DETAILS
SCALE 1:6

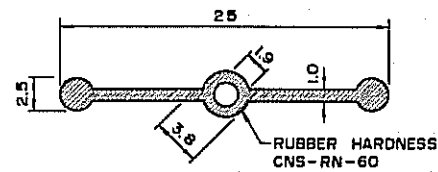

25公分橡皮止水板
25 CM RUBBER WATERSTOP
SCALE 1:30

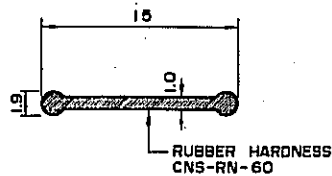

15公分橡皮止水板
15 CM RUBBER WATERSTOP
SCALE 1:30

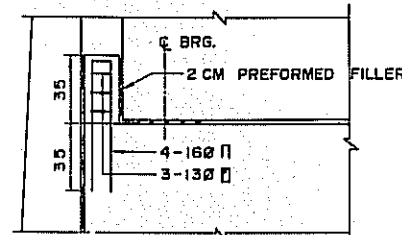
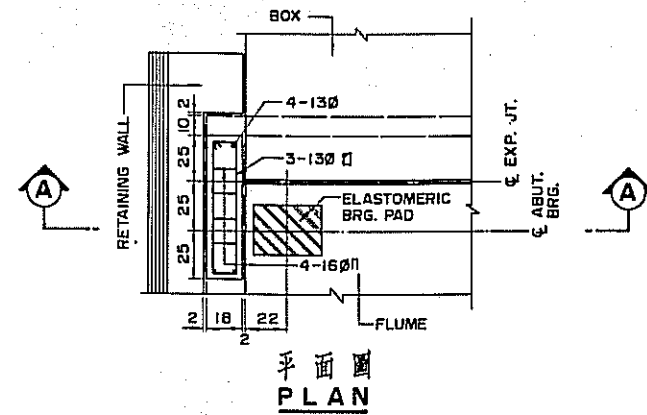

斷面圖 A-A
SECTION A-A
止震塊詳圖
EQ. STOP DETAIL
SCALE 1:30

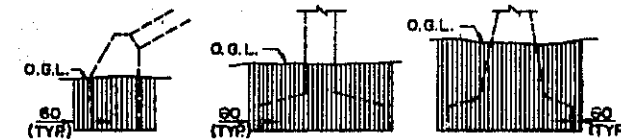

AT HOR. BEAM OF SLOPE PROTECTION AT PIER AT SEMI-GRAVITY ABUT. OR WINGWALL

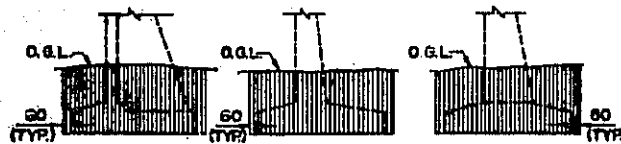

AT COUNTERFORT ABUT. OR WINGWALL AT CANTILEVER ABUT. OR WINGWALL AT SPILL-THROUGH ABUTMENT

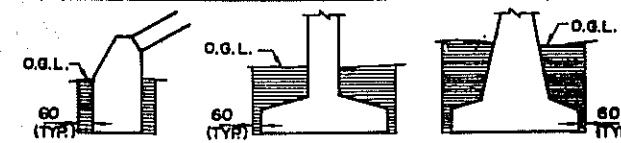

AT HOR. BEAM OF SLOPE PROTECTION AT PIER AT SEMI-GRAVITY ABUT. OR WINGWALL

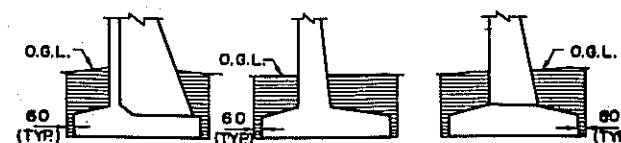

AT COUNTERFORT ABUT. OR WINGWALL AT CANTILEVER ABUT. OR WINGWALL AT SPILL-THROUGH ABUTMENT

結構回填界限
LIMITS FOR BACKFILL OF STRUCTURES

鋼筋彎曲埋入及搭接長度表
TABLE FOR REINFORCING BARS BENDING, EMBEDMENT AND SPLICE

BAR SIZE	DIA. (MM.)	WEIGHT (KG/M)	AREA (CM ²)	MIN. EMBEDMENT LENGTH (CM)			MIN. LAP SPLICES LENGTH (CM)			STANDARD HOOK		STIRRUP & TIE HOOK A (CM.)
				COMP.	TENSION		COMP.	TENSION		180° HOOK A (CM)	90° HOOK A (CM)	
					OTHER	TOP BAR		OTHER	TOP BAR			
100	9.53	0.569	0.713	20	30	30	30	40	40	13	13	9
130	12.7	0.994	1.27	20	30	30	30	40	40	15	17	11
160	15.9	1.55	1.98	20	30	35	35	45	45	18	22	14
190	19.1	2.24	2.85	25	30	45	40	50	55	21	26	17
220	22.2	3.05	3.88	30	40	60	45	70	75	24	30	-
250	25.4	3.98	5.07	35	55	80	50	90	100	28	35	-
290	28.7	5.06	6.45	40	70	100	55	110	125	38	40	-
320	32.3	6.41	8.17	45	90	125	65	135	160	42	45	-
360	35.8	7.91	10.10	50	110	150	75	160	200	47	50	-

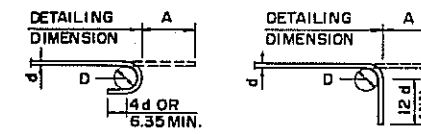

D = 6d FOR 100-250
6d FOR 290-360

(180°) (90°)
標準彎鉤
STANDARD HOOK

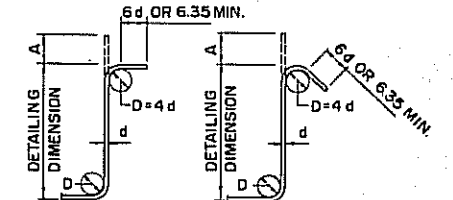

(90°) (135°)
箍及扣條彎鉤
STIRRUP & TIE HOOK

說明:

1. 總說明參照圖 SF-18。
2. 可用焊接或其他可行之連接方法以代替重疊搭接。當採用焊接時，所有焊接方法及材料均須符合規範 "AWS-D12.1" 之規定。
3. 除工程師之准許外，所有鋼筋必須冷彎。
4. 除圖面註明或工程師之准許外，不得將鋼筋部份埋入混凝土後再行彎曲之。

NOTES:

1. FOR GENERAL NOTES SEE SHEET SF-18.
2. WELDED SPLICES OR OTHER POSITIVE CONNECTIONS MAY BE USED INSTEAD OF LAPPED SPLICES AS PROVIDED HEREIN. ALL WELDING SHALL CONFORM TO AWS-D12.1 "RECOMMENDED PRACTICES FOR WELDING REINFORCING STEEL, METAL INSERTS AND CONNECTIONS IN REINFORCED CONCRETE CONSTRUCTION."
3. ALL BARS SHALL BE BENT COLD, UNLESS OTHERWISE PERMITTED BY THE ENGINEER.
4. NO BARS PARTIALLY EMBEDDED IN CONCRETE SHALL BE FIELD BENT EXCEPT AS SHOWN ON THE PLANS OR PERMITTED BY THE ENGINEER.

PROJECT 60

修正 REVISIONS	項目 ITEM	日期 DATE	交通部台灣區高速公路工程局 TAIWAN AREA FREEWAY CONSTRUCTION BUREAU
			中華民國 REPUBLIC OF CHINA
			南北高速公路 NORTH-SOUTH FREEWAY
			苗栗台中段 MIAOLI-TAICHUNG SECTION
			波槽 FLUME
			防震拉條止水板及雜項詳圖 EQ. TIE, WATERSTOP & MISC. DETAILS
			中華顧問工程司 CHINA ENGINEERING CONSULTANTS, INC.
			日期 DATE AUG. '74 比例 SCALE AS SHOWN 圖號 SHEET SF-21

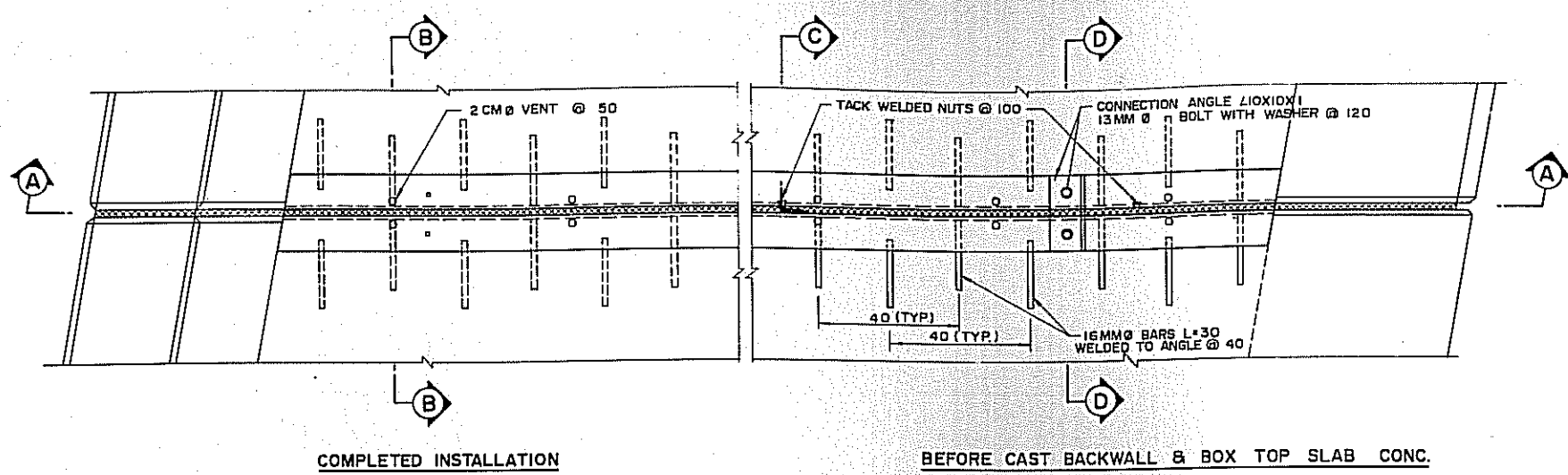

平面圖
PLAN
SCALE 1:10

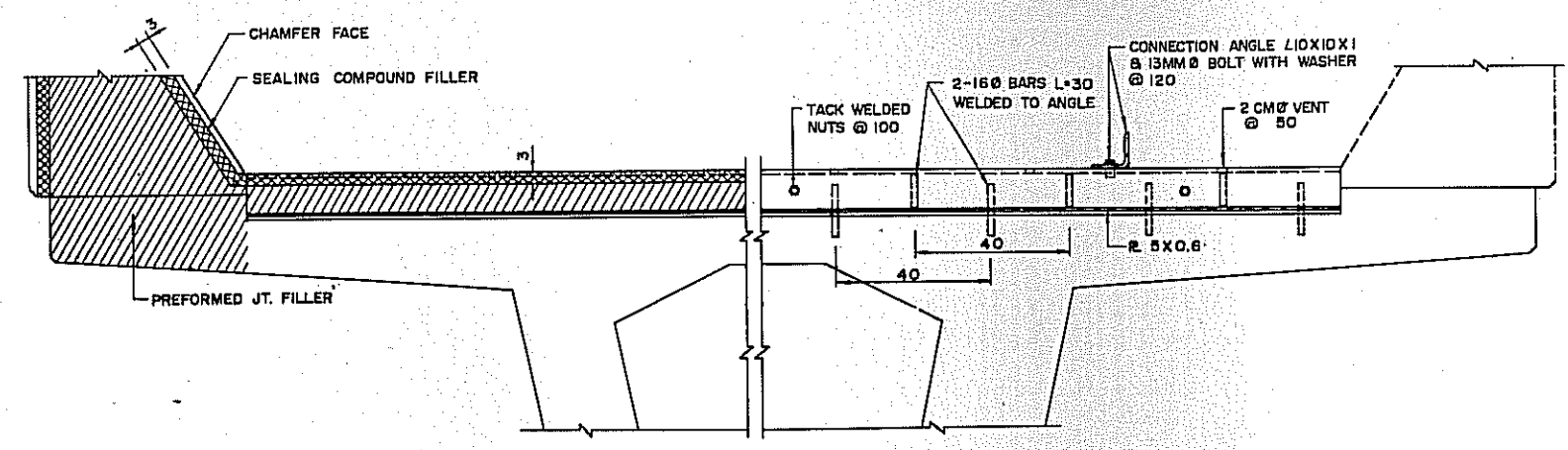

斷面圖 A-A
SECTION A-A
SCALE 1:10

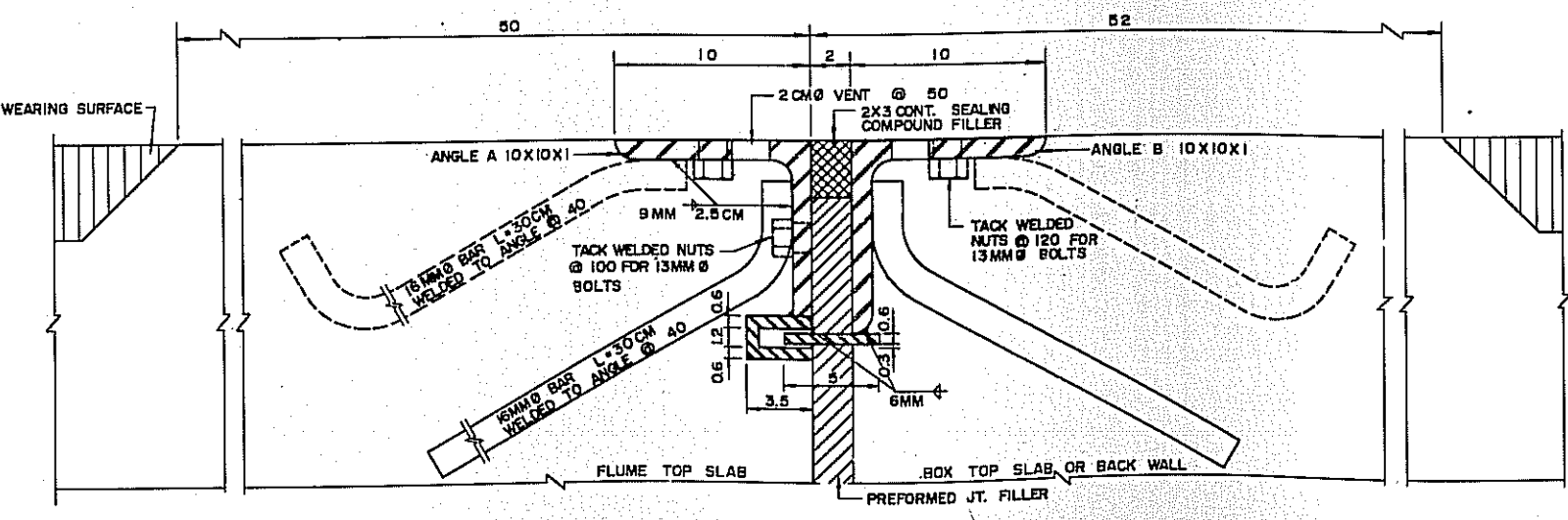

斷面圖 B-B
SECTION B-B
SCALE 1:2

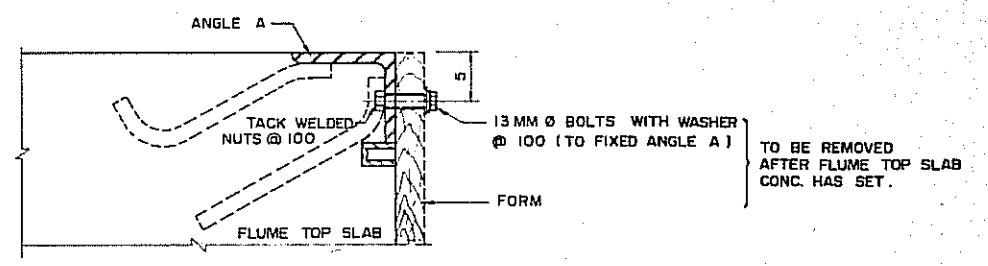

斷面圖 C
SECTION C
SCALE 1:4

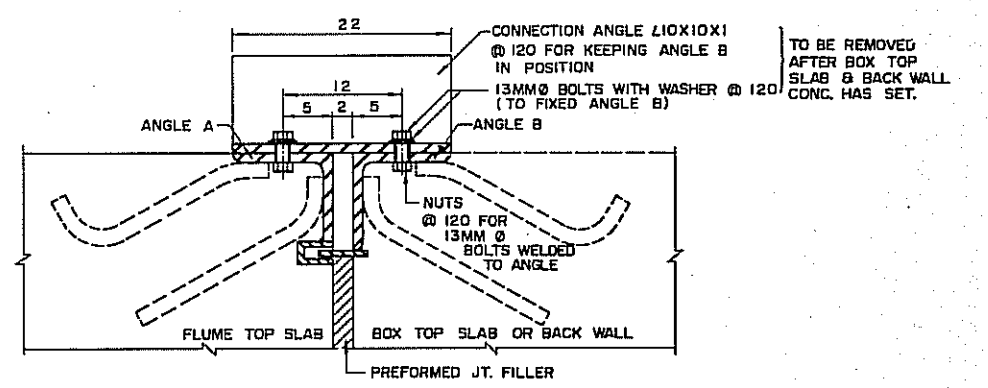

斷面圖 D-D
SECTION D-D
SCALE 1:4

說明:

1. 各項尺寸除另有註明者外，單位均以公分計。
2. 角鋼及鋼板均須合於 ASTM-A36 之規定。
3. 鋼鐵組件須經熱浸鍍鋅處理。
4. 焊接材料及方法須合於 AWS 出版之“公路及鐵路橋之焊接規範”。
5. 伸縮縫頂面須與路面坡度一致。

NOTES:

1. ALL DIMENSIONS ARE IN CM UNLESS OTHERWISE NOTED.
2. ANGLE B PLATES SHALL BE MILD STEEL CONFORMING TO ASTM-A-36.
3. STEEL COMPONENTS SHALL BE HOT DIP GALVANIZED AFTER FABRICATION.
4. WELDING MATERIAL AND METHODS SHALL CONFORM TO AWS SPECIFICATION FOR WELDED HIGHWAY & RAILWAY BRIDGES.
5. THE TOP FACE OF EXPANSION JOINT SHOULD COINCIDE WITH ROADWAY GRADE.

PROJECT 60

修正 REVISIONS	項目 ITEM	日期 DATE	交通部台灣區高速公路工程局 TAIWAN AREA FREEWAY CONSTRUCTION BUREAU 中華民國 REPUBLIC OF CHINA
			南北高速公路 NORTH-SOUTH FREEWAY 苗栗台中段 MIAOLI-TAICHUNG SECTION
			溪槽 (133+680.50) FLUME
			伸縮縫詳圖 EXPANSION JOINT DETAILS
			中華顧問工程司 CHINA ENGINEERING CONSULTANTS, INC.
			日期 DATE AUG. '74 比例 SCALE AS SHOWN 圖號 SHEET SF-22

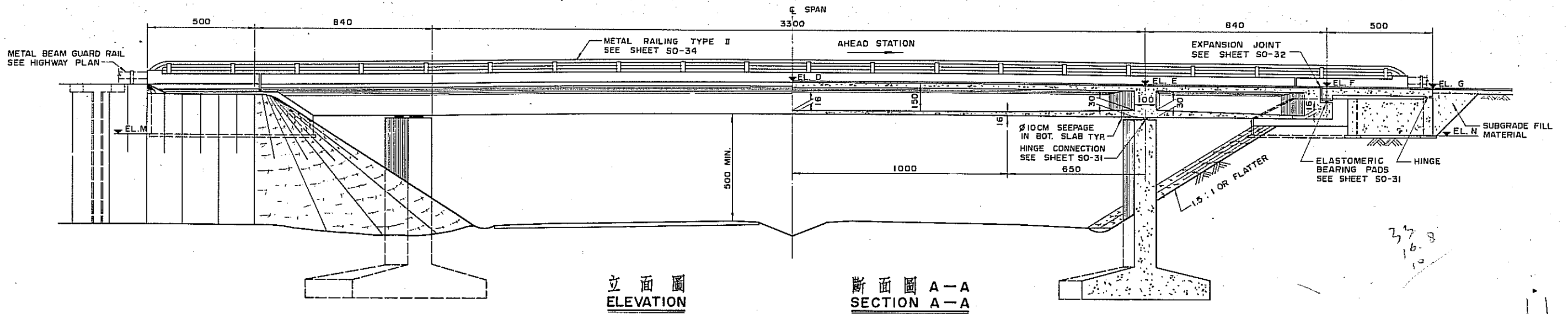

立面圖
ELEVATION

斷面圖 A-A
SECTION A-A

37
16.8
10

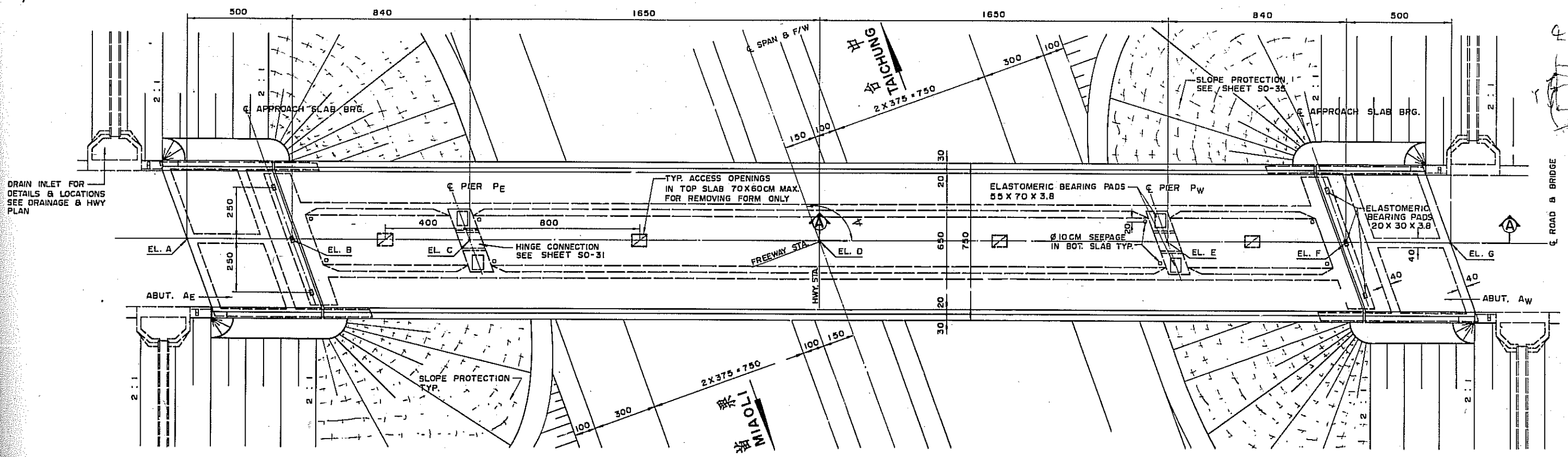

平面圖
PLAN

說明：
請說明參照圖 SO-36。

NOTE:
FOR GENERAL NOTES SEE SHEET SO-36.

PR. NO.	STATION FREEWAY	STATION HIGHWAY	CROSS-ANGLE A	ELEVATIONS (ON TOP OF WEARING SURFACE)								ELEVATIONS		REMARKS
				A	B	C	D	E	F	G	M	N		
55	109+682.11	0+541.17	105° 48' 01"	94.668	94.634	94.548	94.276	93.869	93.609	93.437	92.180	90.960	35	
60	134+593.90	0+330.39	108° 26' 49"	211.965	212.043	212.142	212.220	212.142	212.043	211.965	209.490	209.490	37	
60	137+145.98	0+287.35	105° 34' 34"	199.155	199.233	199.332	199.410	199.332	199.233	199.155	196.680	196.680	31	
62	141+154.76	10+266.28	104° 56' 30"	182.839	182.894	182.953	182.950	182.788	182.645	182.540	180.360	180.060	62	
63	148+344.41	0+457.09	110° 14' 57"	142.515	142.593	142.692	142.770	142.692	142.593	142.515	140.040	140.040		

PROJECT 60

修正 REVISIONS	項目 ITEM	日期 DATE

交通部台灣區高速公路工程局
TAIWAN AREA FREEWAY CONSTRUCTION BUREAU
中華民國
中華人民共和國
南北高速公路 NORTH-SOUTH FREEWAY
苗栗台中段 MIAOLI-TAICHUNG SECTION
單車道跨橋 (134+593.90) (137+145.98) 1-LANE OVERCROSSING
橋平面圖
中華顧問工程司 CHINA ENGINEERING CONSULTANTS, INC.
日期 DATE AUG. '74 比例 SCALE 1:100 圖號 SHEET SO-1

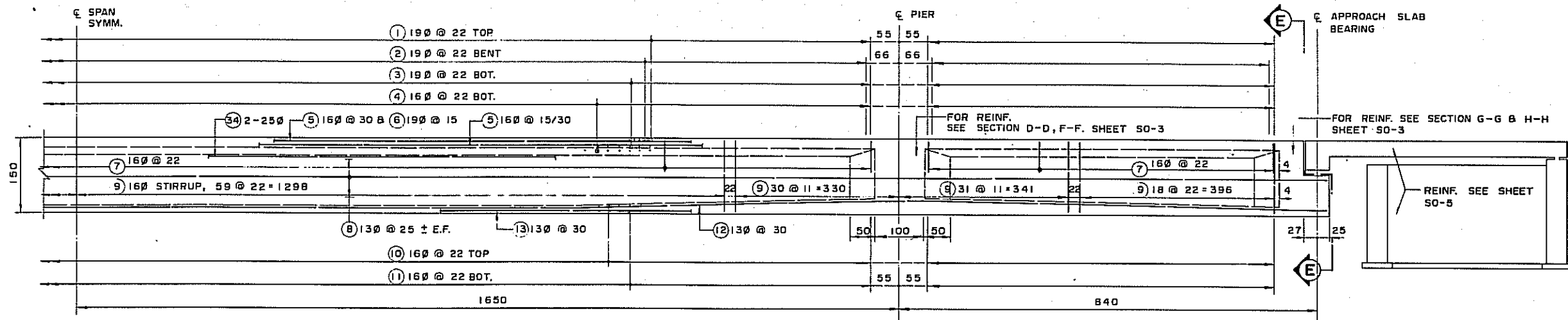

斷面圖 B-B
SECTION B-B
SCALE 1:50

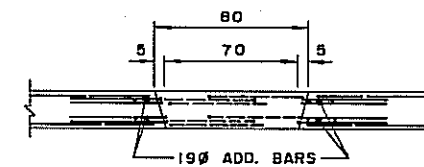

斷面圖 J-J
SECTION J-J

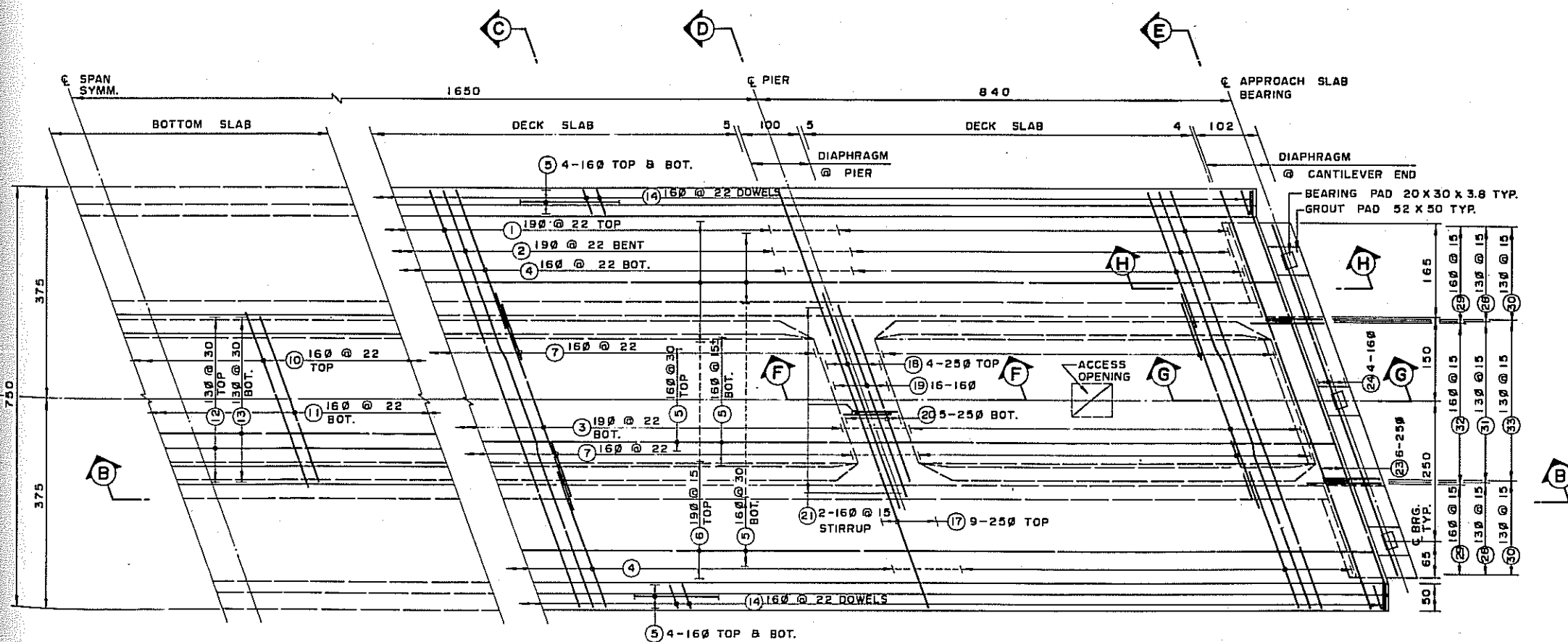

平面圖
PLAN
SCALE 1:50

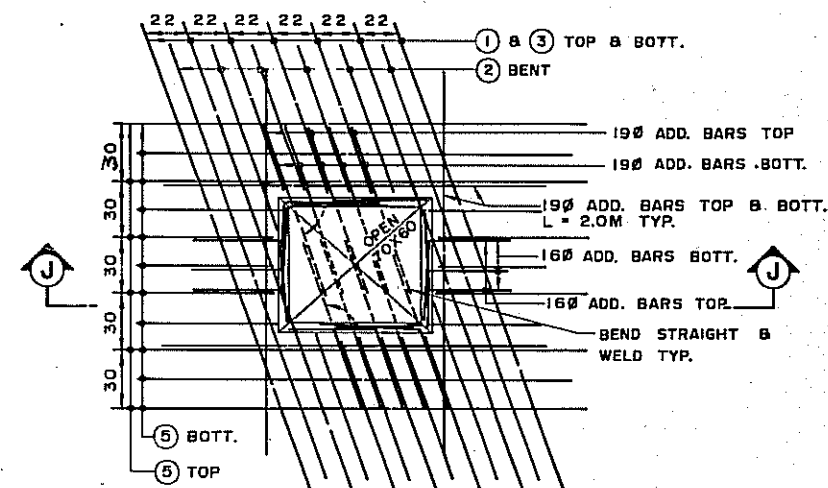

平面圖
PLAN
臨時孔道標準配筋圖
TYP. REINF. AT ACCESS OPENING
SCALE 1:20

說明:
標說明參照圖 SO-36

NOTE:
FOR GENERAL NOTES SEE SHEET SO-36.

修正 REVISIONS	項目 ITEM	日期 DATE	交通部台灣區高速公路工程局 TAIWAN AREA FREEWAY CONSTRUCTION BUREAU 中華民國 REPUBLIC OF CHINA
			南北高速公路 NORTH-SOUTH FREEWAY 苗栗台中段 MIAOLI-TAICHUNG SECTION
			單線跨橋 (134+593.90) 1-LANE OVERCROSSING (137+145.98)
			上部結構鋼筋詳圖(I) SUPERSTR. REINF. DETAIL(I)
			中華顧問工程司 CHINA ENGINEERING CONSULTANTS, INC.
			日期 DATE AUG. '74 比例 SCALE AS SHOWN 圖號 SHEET 50-2

PROJECT 60

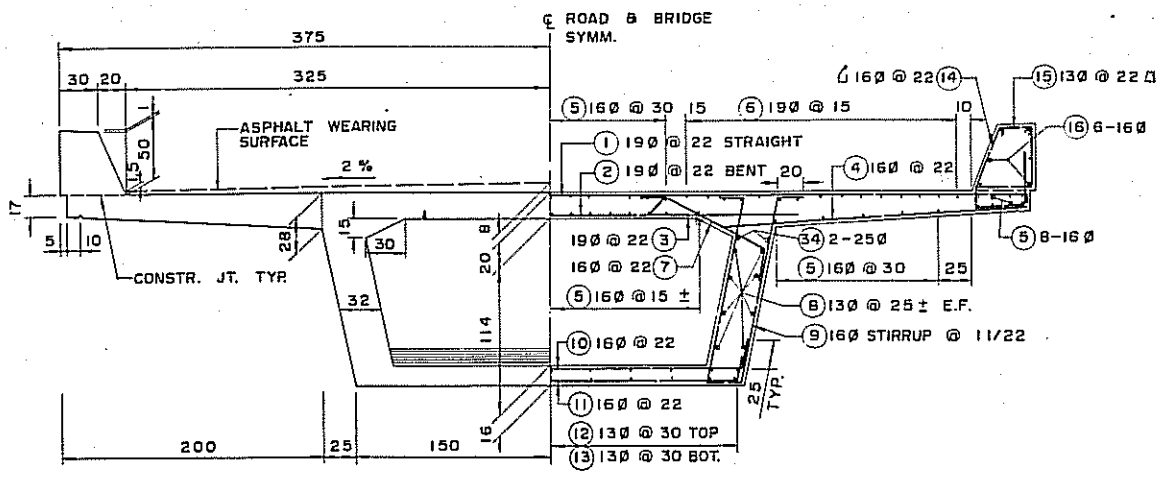

斷面圖 C-C
SECTION C-C
SCALE 1:30

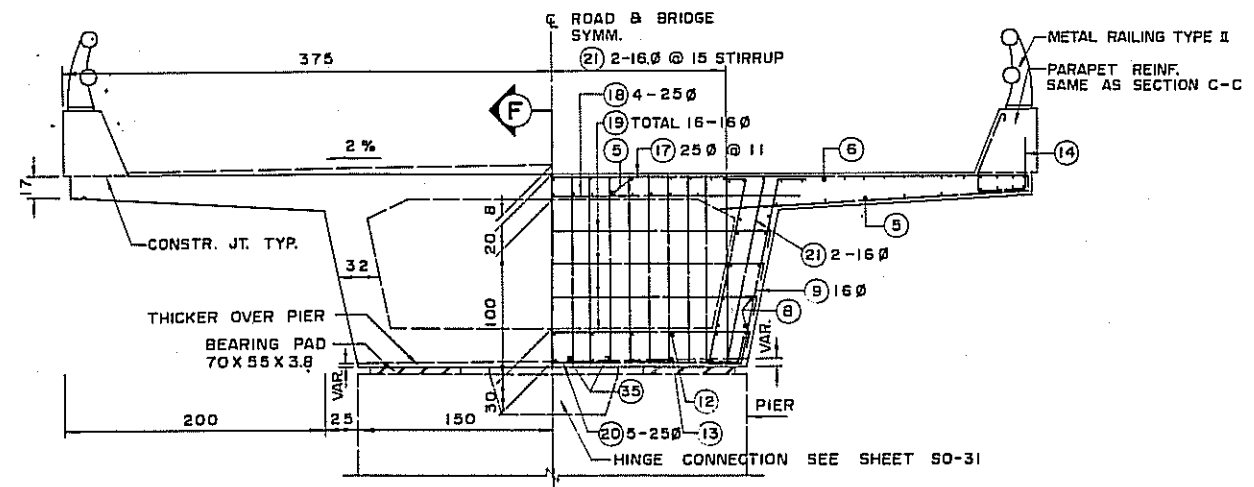

斷面圖 D-D
SECTION D-D
SCALE 1:30

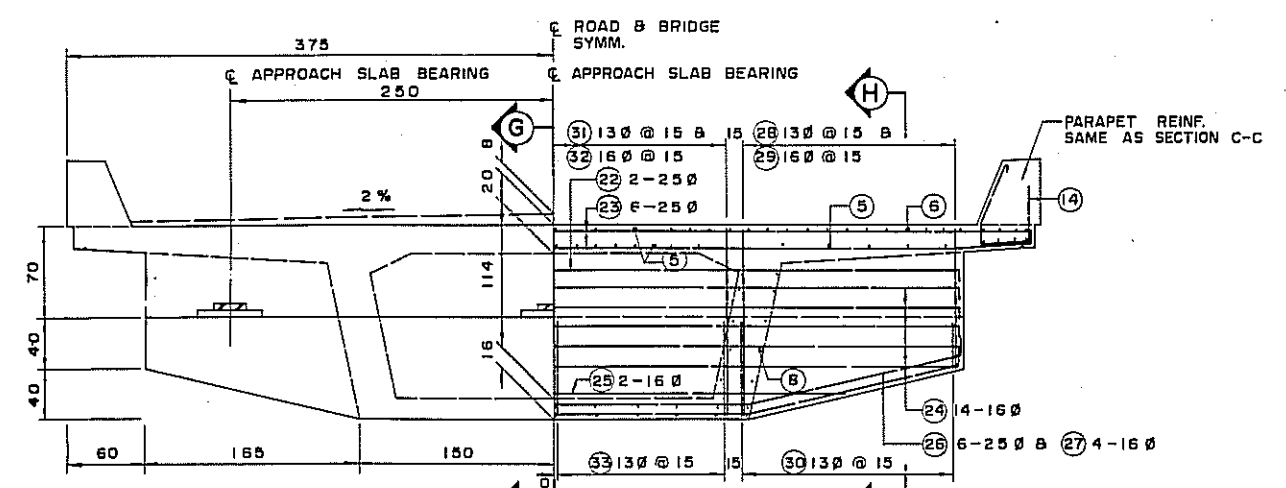

斷面圖 E-E
SECTION E-E
SCALE 1:30

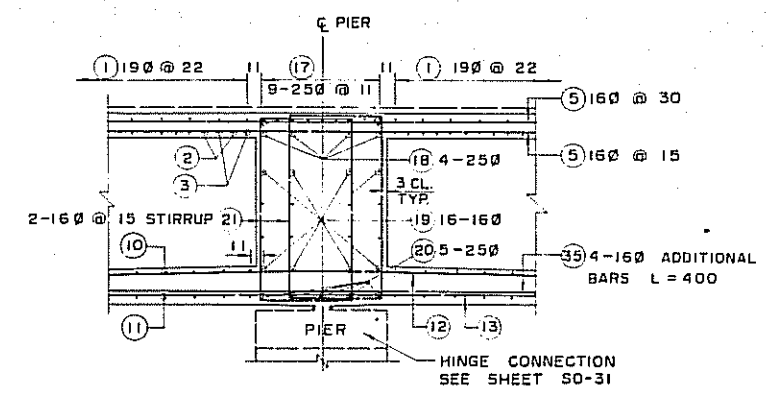

斷面圖 F-F
SECTION F-F
SCALE 1:30

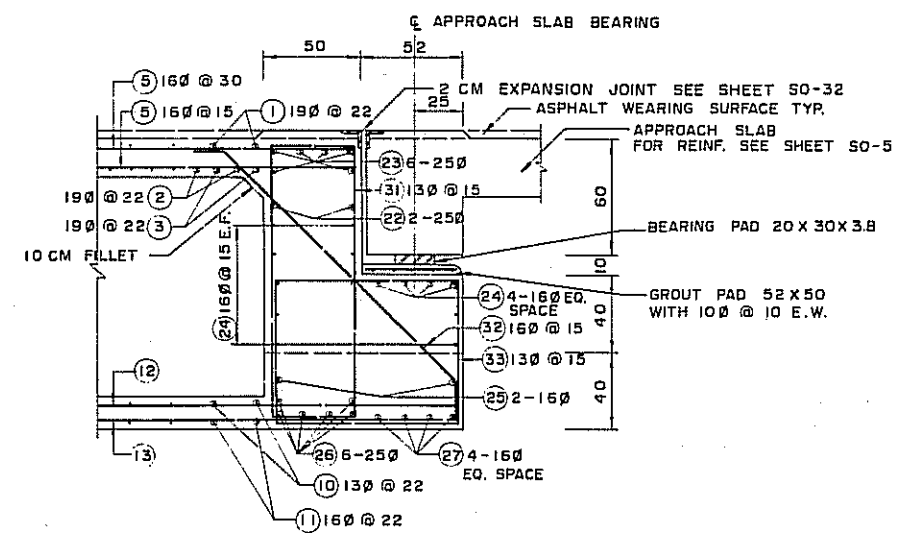

斷面圖 G-G
SECTION G-G
SCALE 1:20

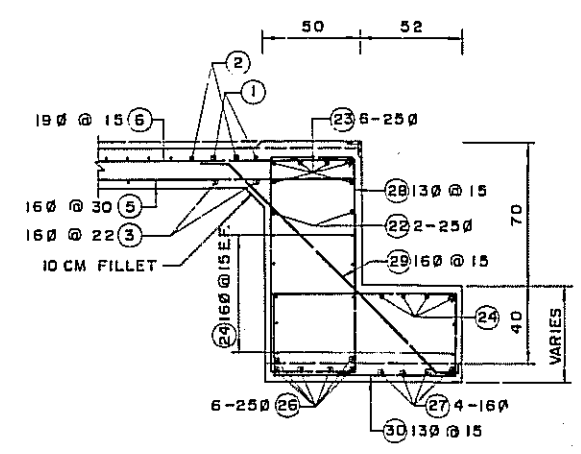

斷面圖 H-H
SECTION H-H
SCALE 1:20

鋼筋表
LIST OF REINFORCING STEELS

SHAPE	NOMINAL DIA. (MM)	REMARK
1	19Ø	@ 22
2	19Ø	@ 22
3	19Ø	@ 22
4	16Ø	@ 22
5	16Ø	@ 15/30
6	19Ø	@ 15/30
7	16Ø	@ 22
8	13Ø	
9	16Ø	@ 11/22
10	16Ø	@ 22
11	16Ø	@ 22
12	13Ø	@ 30
13	13Ø	@ 30
14	16Ø	@ 22
15	13Ø	@ 22
16	16Ø	
17	25Ø	
18	25Ø	
19	16Ø	
20	25Ø	
21	16Ø	@ 15
22	25Ø	
23	25Ø	
24	16Ø	@ 15
25	16Ø	
26	25Ø	
27	16Ø	
28	13Ø	@ 15
29	16Ø	@ 15
30	13Ø	@ 15
31	13Ø	@ 15
32	16Ø	@ 15
33	13Ø	@ 15
34	16Ø	@ 15
35	16Ø	
36	10Ø	BEHIND FREYSSH NET CONE ONLY

PROJECT 60
交通部台灣區高速公路工程局
TAIWAN AREA FREEWAY CONSTRUCTION BUREAU
中華民國
REPUBLIC OF CHINA
南北高速公路 NORTH-SOUTH FREEWAY
苗栗台中段 MIAOLI-TAICHUNG SECTION
單車道跨橋 (134+593.90) I-LANE OVERCROSSING
(137+145.98)
上部結構鋼筋詳圖(II) SUPERSTR. REINF. DETAIL(II)
中華顧問工程司 CHINA ENGINEERING CONSULTANTS, INC.
日期 DATE AUG. '74 比例 SCALE AS SHOWN 圖號 SHEET SO-3

修正	REVISIONS
項目	ITEM
日期	DATE

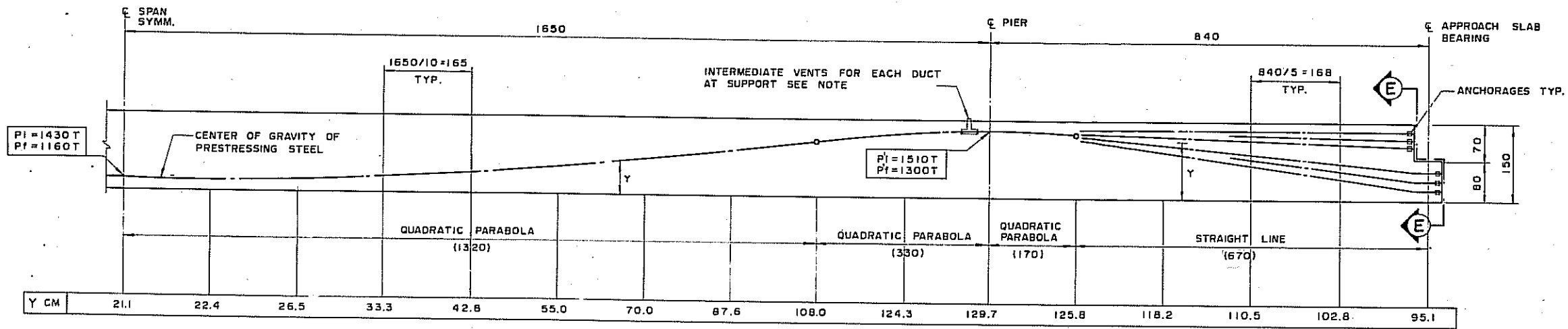

立面圖
ELEVATION
SCALE 1:50

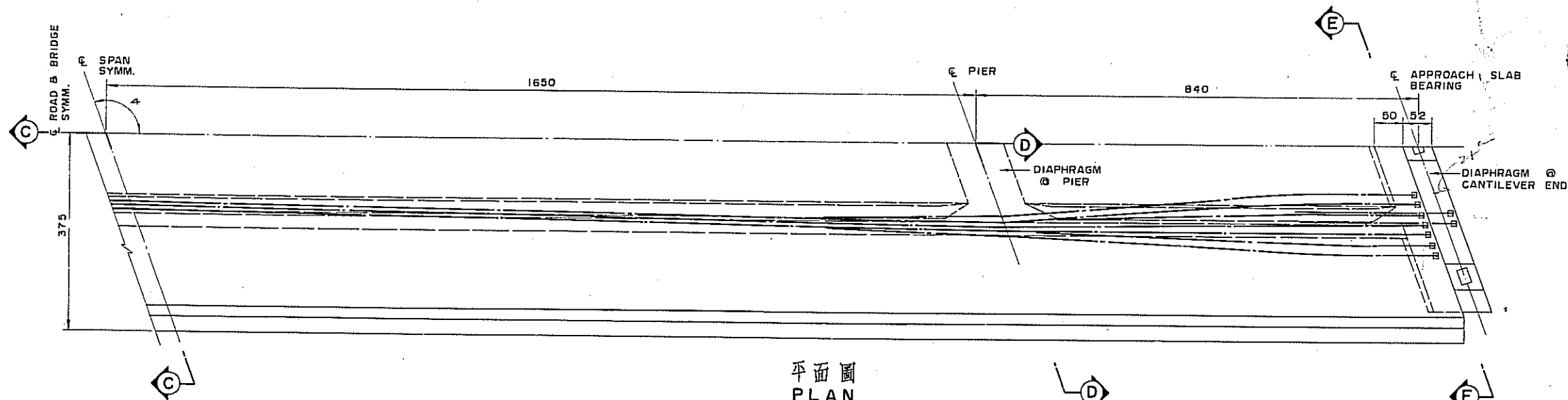

平面圖
PLAN
SCALE 1:50

說明：
總說明及預力混凝土箱樑說明參照圖 50-36。
NOTE：
FOR GENERAL NOTES & NOTES FOR P.C. BOX GIRDER SEE SHEET 50-36.

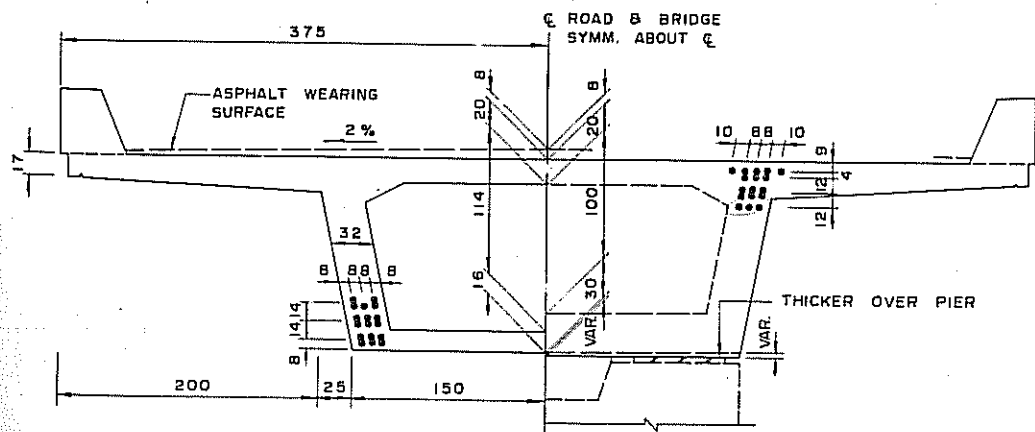

斷面圖 C-C
SECTION C-C
SCALE 1:30

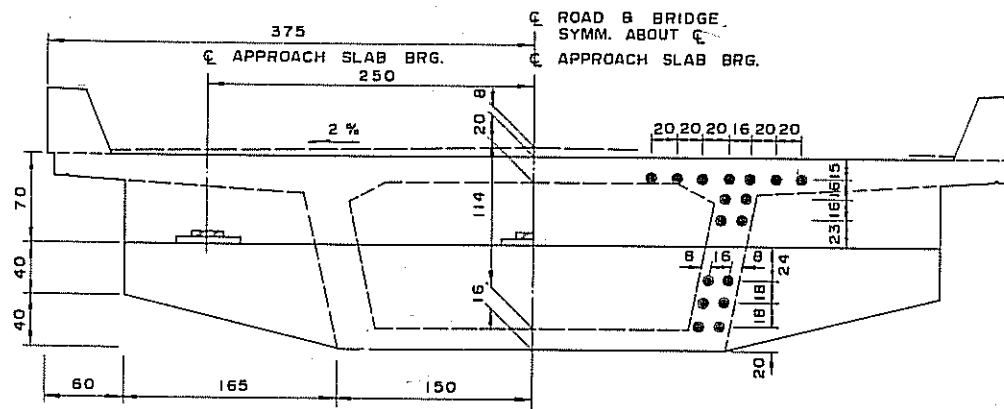

斷面圖 D-D
SECTION D-D
SCALE 1:30

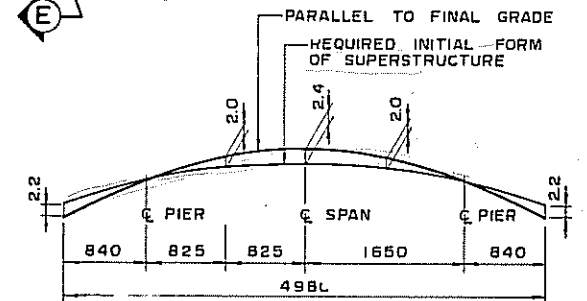

TOTAL DEAD LOAD + PRESTRESSED FORCE
撓度示意圖
DEFLECTION DIAGRAM
N.T.S.

(FOR REFERENCE ONLY)

PROJECT 60

修正 項目	REVISIONS ITEM	日期 DATE	交通部台灣區高速公路工程局 TAIWAN AREA FREEWAY CONSTRUCTION BUREAU 中華民國 REPUBLIC OF CHINA	
			南北高速公路 苗栗台中段	NORTH-SOUTH FREEWAY MIAOLI-TAICHUNG SECTION
			單車道跨線橋 (34+593.90) (137+145.98)	1-LANE OVERCROSSING
			鋼絞佈置詳圖	TENDON LAYOUT DETAILS
			中華顧問工程司	CHINA ENGINEERING CONSULTANTS, INC.

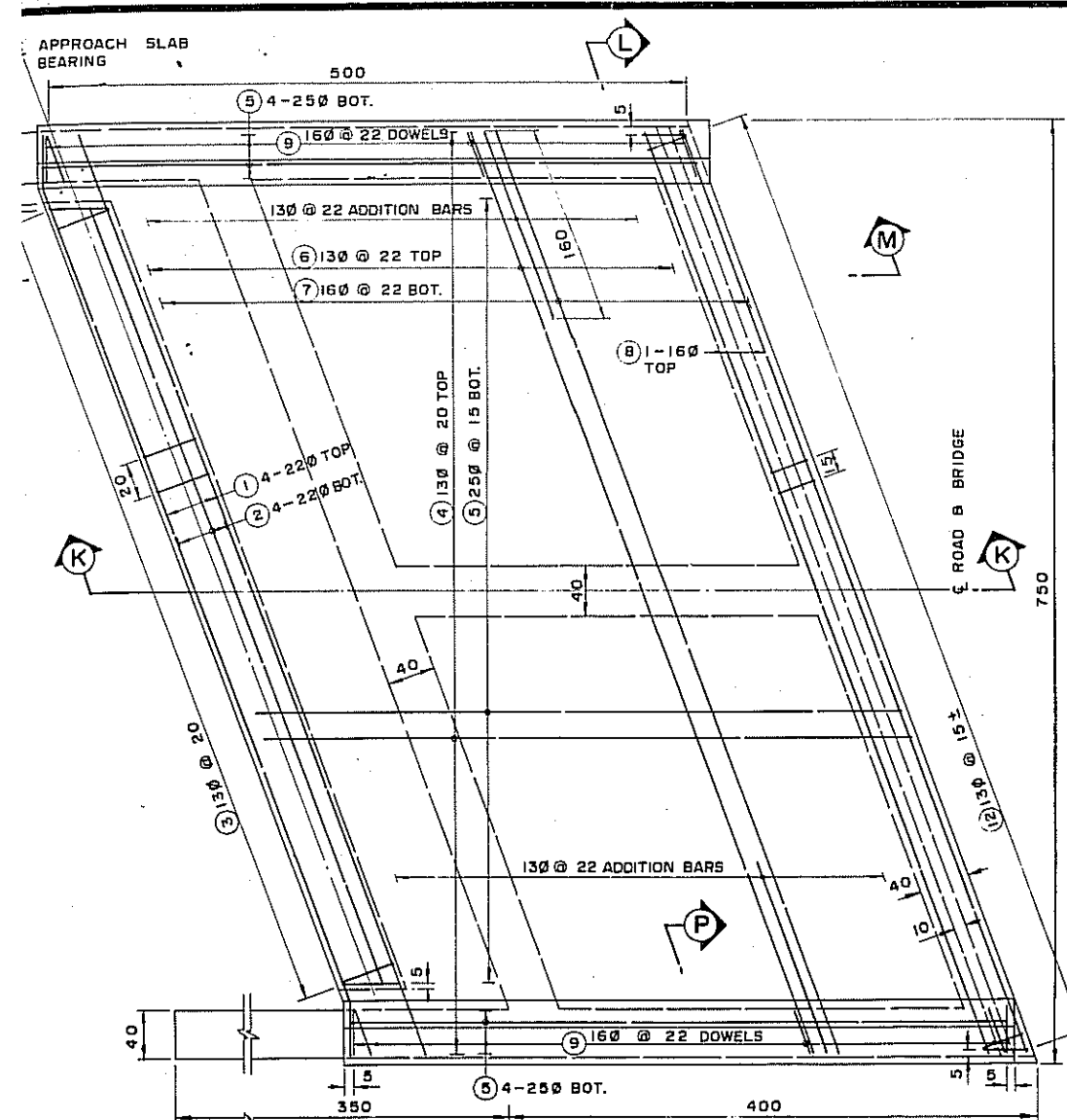

平面圖
PLAN
SCALE 1:30

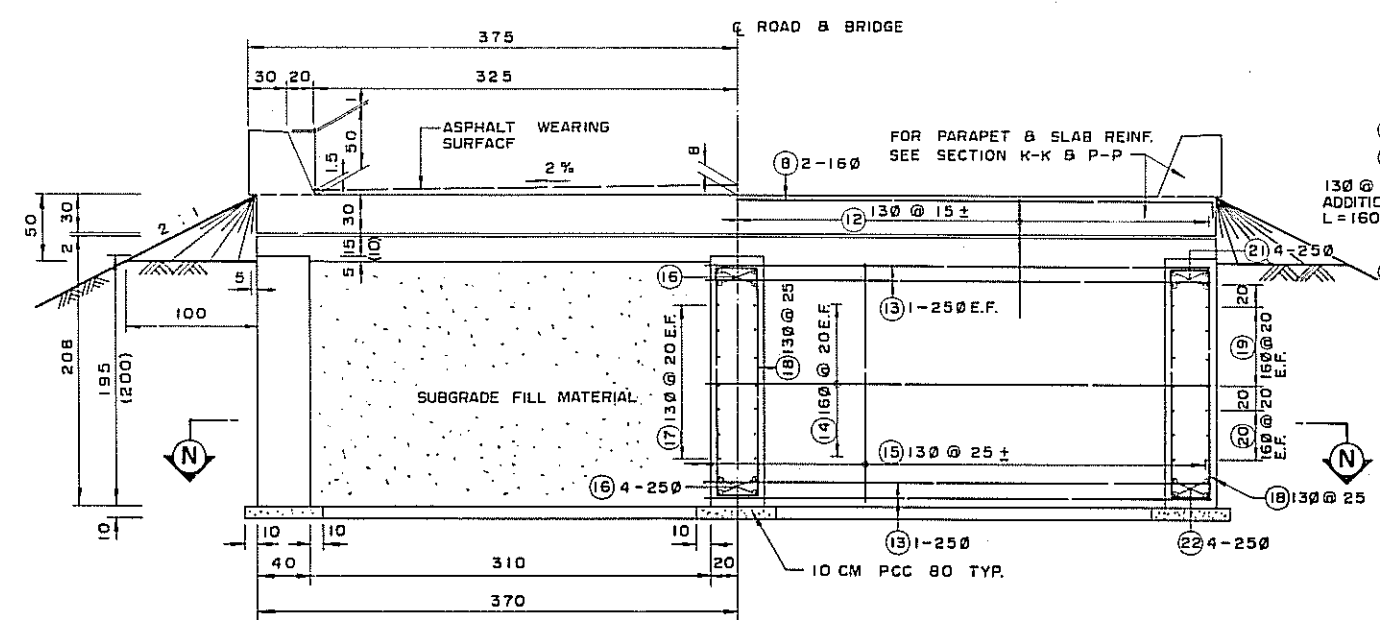

斷面圖 L-L
SECTION L-L
SCALE 1:30

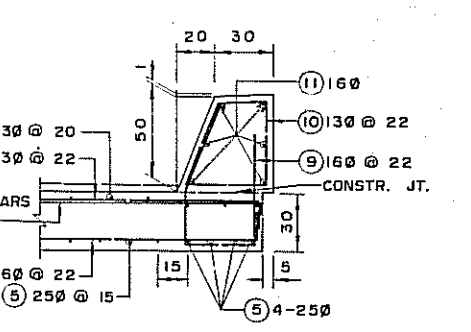

斷面圖 P-P
SECTION P-P
SCALE 1:20

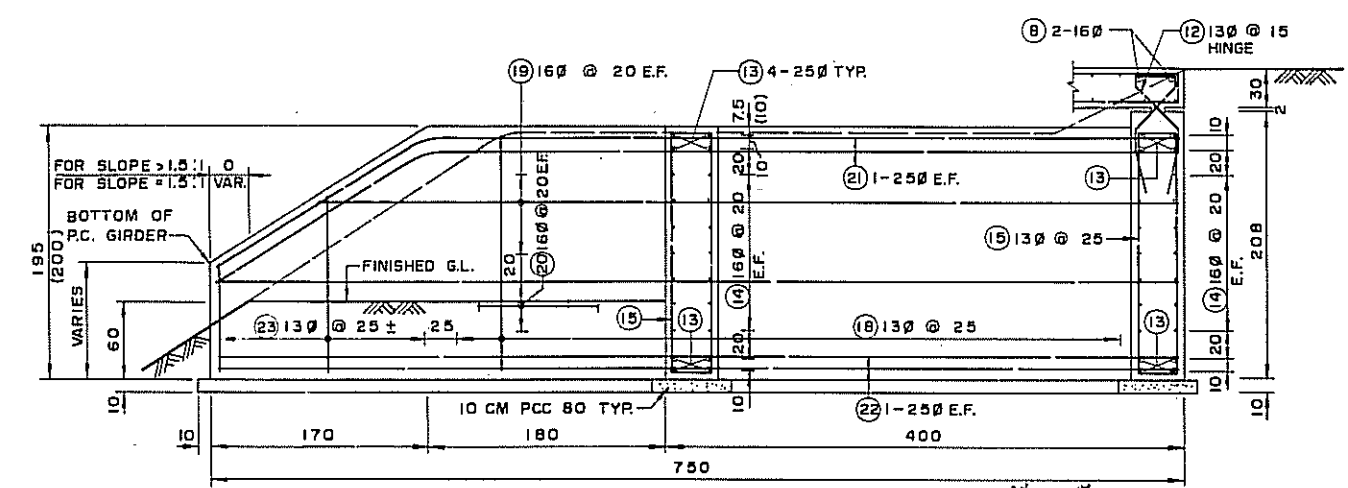

斷面圖 M-M
SECTION M-M
SCALE 1:30

鋼筋表
LIST OF REINFORCING STEELS.

SHAPE	NOMINAL DIA. (MM)	REMARK
①	22φ	
②	22φ	
③	13φ	@ 20
④	13φ	@ 20
⑤	25φ	@ 15
⑥	13φ	@ 22
⑦	16φ	@ 22
⑧	16φ	
⑨	16φ	@ 22
⑩	13φ	@ 22
⑪	16φ	
⑫	13φ	@ 15
⑬	25φ	
⑭	16φ	@ 20
⑮	13φ	@ 25
⑯	25φ	
⑰	13φ	@ 20
⑱	13φ	@ 20
⑲	16φ	@ 20
⑳	16φ	@ 20
㉑	25φ	
㉒	25φ	
㉓	13φ	L = VARIES

說明：
 1. 參閱說明圖 50-36。
 2. 箱底填土需確實夯實。
 3. () 內之尺寸僅適用於橋號 109+682.11 之橋台 Aw。
 NOTES:
 1. FOR GENERAL NOTES SEE SHEET 50-36.
 2. FILLING MATERIAL UNDER THE BOX SHOULD BE WELL COMPACTED.
 3. DIMENSIONS IN () ARE FOR ABUT. Aw OF STATION 109 + 682.11 ONLY.

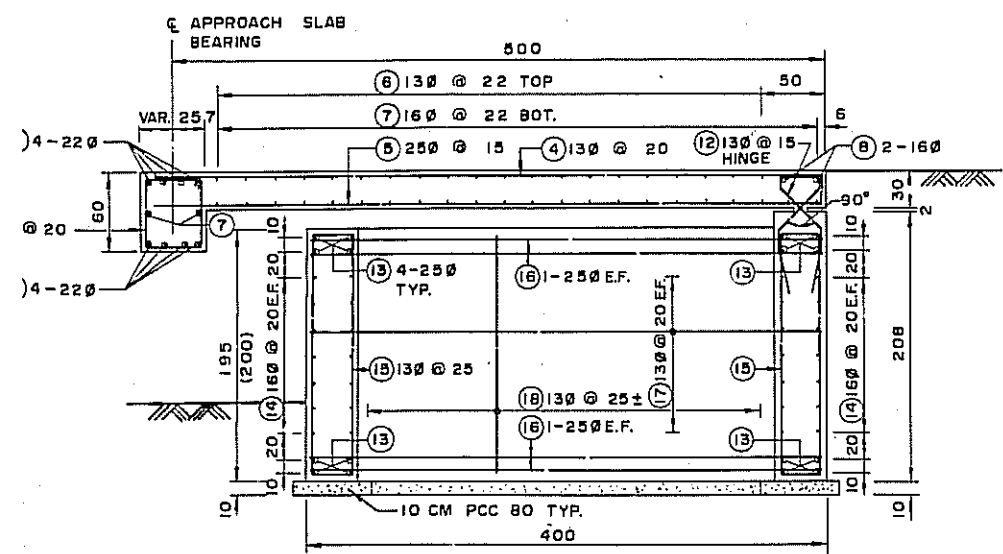

斷面圖 K-K
SECTION K-K
SCALE 1:30

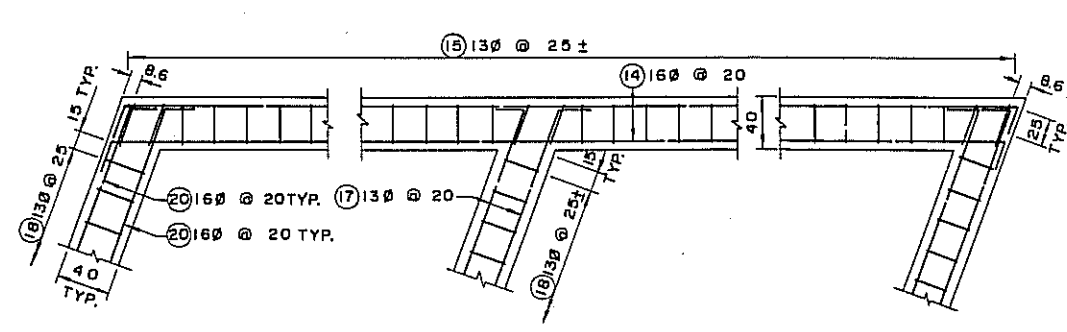

斷面圖 N-N
SECTION N-N
SCALE 1:30

PROJECT 60

修正	REVISIONS	交通部台灣區高速公路工程局
項目	ITEM 日期 DATE	TAIWAN AREA FREEWAY CONSTRUCTION BUREAU
		中華民國
		南北高速公路 NORTH-SOUTH FREEWAY
		苗栗台中段 MIAOLI-TAICHUNG SECTION
		單線跨線橋 (134+593.90) I-LANE OVERCROSSING
		引道及橋台鋼筋圖 APPROACH SLAB & ABUT. REINF. DETAILS
		中華顧問工程司 CHINA ENGINEERING CONSULTANTS, INC.
		日期 DATE AUG. '74 比例 SCALE AS SHOWN 圖號 SHEET 50-5

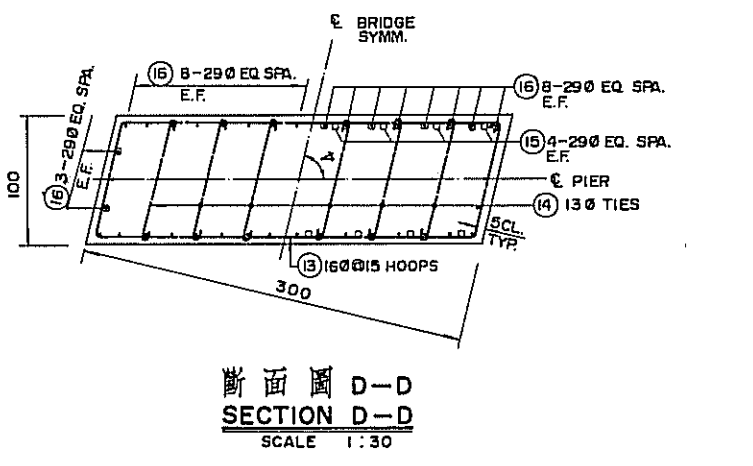
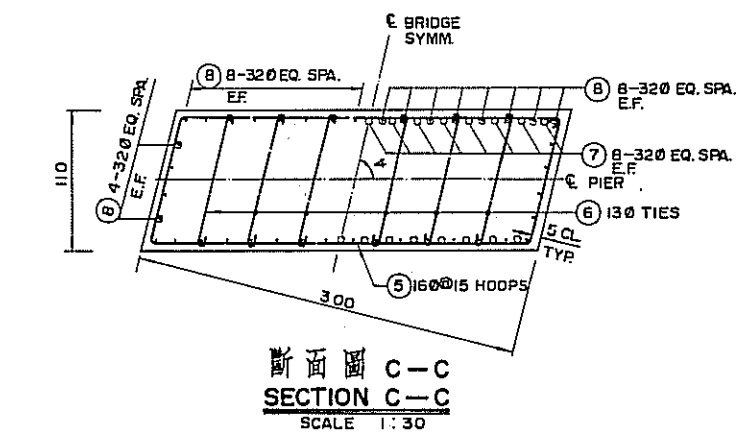
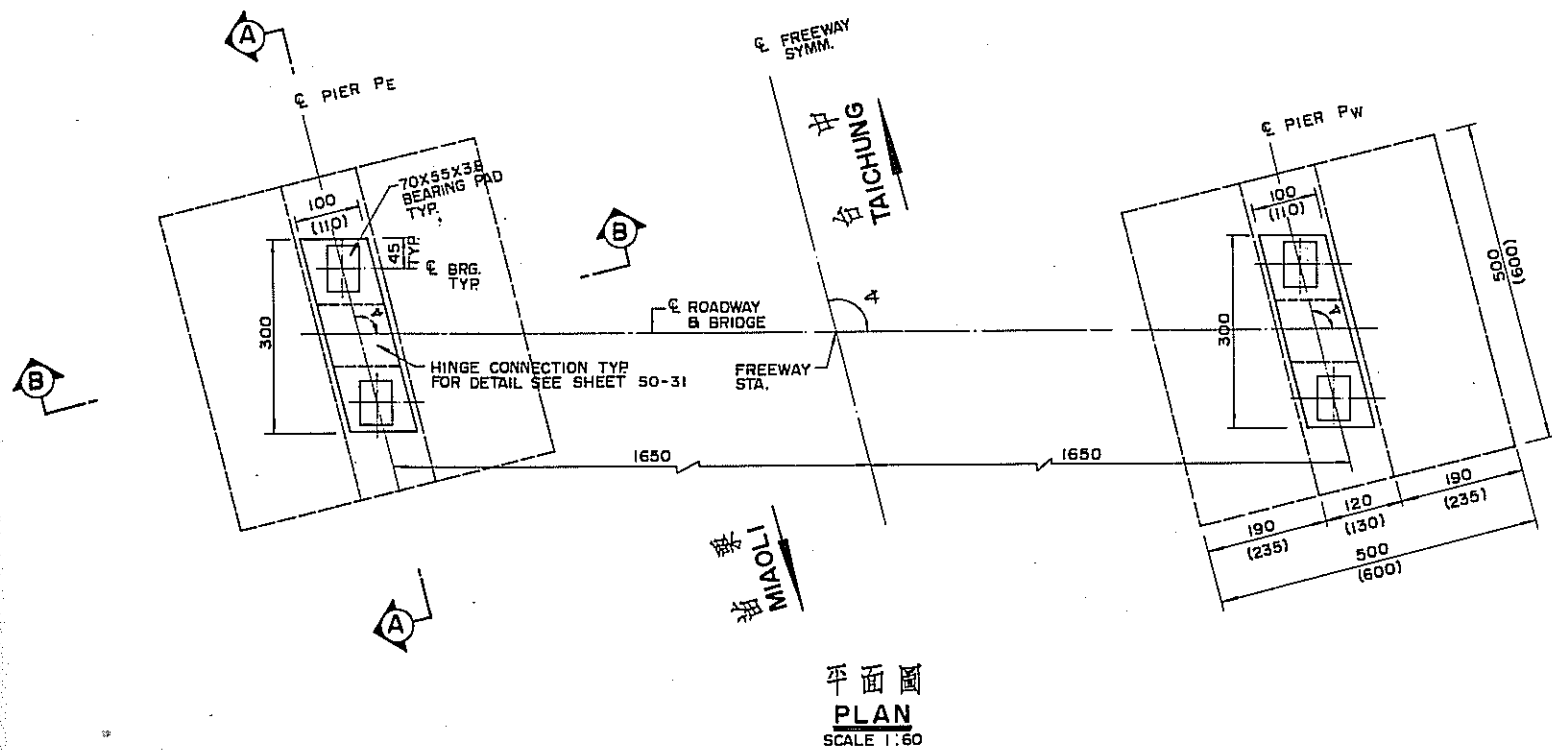

鋼筋表
LIST OF REINFORCING STEELS

SHAPE	NOMINAL DIA. (MM)	REMARK
①	290	@ 18
②	190	@ 20
③	190	@ 18
④	160	
⑤	160	LENGTH VARIES
⑥	130	"
⑦	320	
⑧	320	LENGTH VARIES
⑨	290	@ 22
⑩	190	@ 22
⑪	190	@ 22
⑫	160	@ 44
⑬	160	LENGTH VARIES
⑭	130	"
⑮	290	
⑯	290	LENGTH VARIES

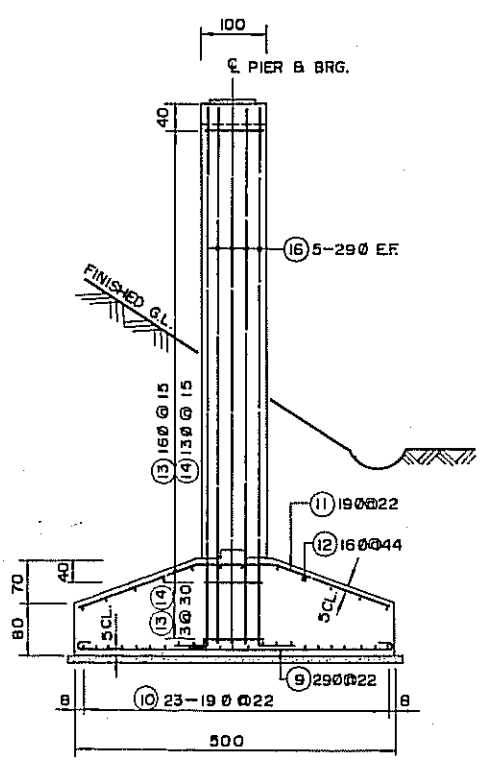
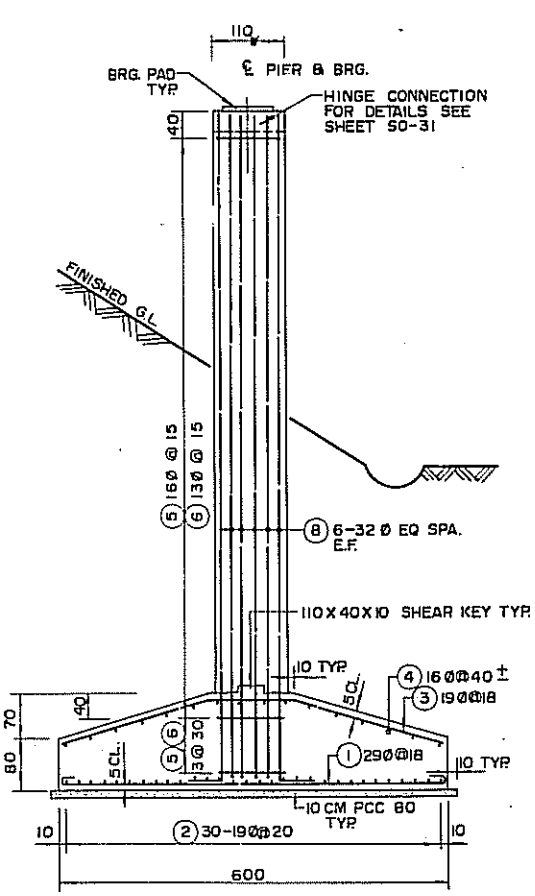
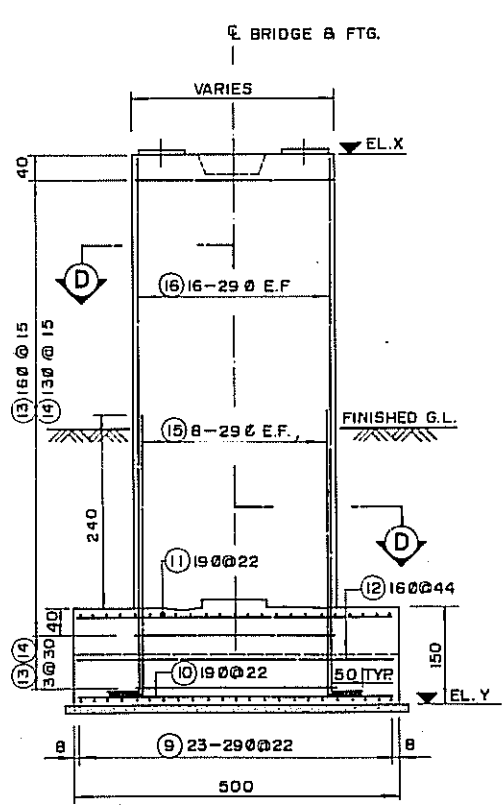
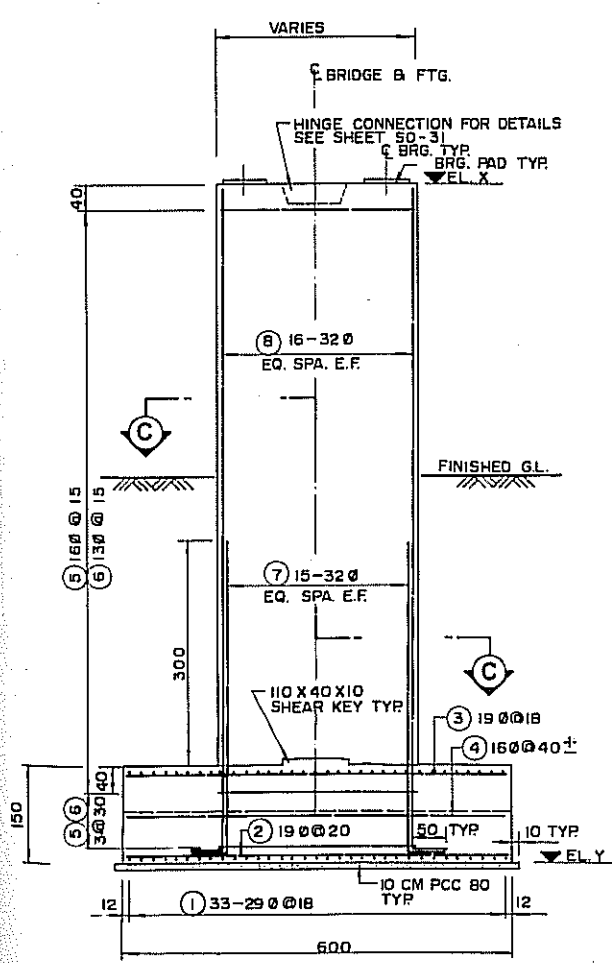

高程表
LIST OF ELEVATIONS

STA. FREEWAY	CROSS ANGLE	PIER	TYPE	ELEVATIONS (M)	
				X	Y
109 + 682.11	105° 48' 01"	PE	I	92.910	82.700
		PW	I	92.220	82.700
134 + 593.90	109° 26' 49"	PE	I	210.510	200.300
		PW	I	210.510	200.300
137 + 145.98	105° 34' 34"	PE	I	197.690	187.500
		PW	I	197.690	187.500
141 + 154.76	104° 56' 30"	PE	II	181.320	173.500
		PW	II	181.150	173.000
148 + 344.41	110° 14' 57"	PE	I	141.050	131.200
		PW	I	141.050	131.200

說明:
詳說明參照圖 50-36

NOTE:
FOR GENERAL NOTES SEE SHEET 50-36.

PROJECT 60

修正	REVISIONS	項目	日期	DATE

交通部台灣區高速公路工程局
TAIWAN AREA FREEWAY CONSTRUCTION BUREAU
中華民國
REPUBLIC OF CHINA
南北高速公路 NORTH-SOUTH FREEWAY
苗栗台中段 MIAOLI-TAICHUNG SECTION
1-車道跨線橋 (134+593.90) 1-LANE OVERCROSSING
(137+145.98) PIER REIN. DETAILS
橋墩鋼筋詳圖
中華顧問工程司 CHINA ENGINEERING CONSULTANTS, INC.
日期 DATE AUG. 74 比例 SCALE AS SHOWN 圖號 SHEET 50-6

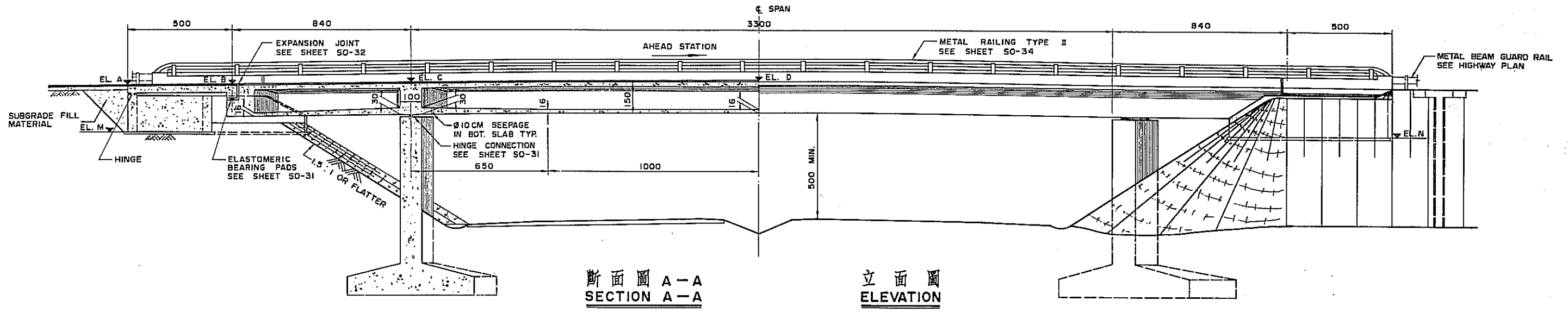

斷面圖 A-A
SECTION A-A

立面圖
ELEVATION

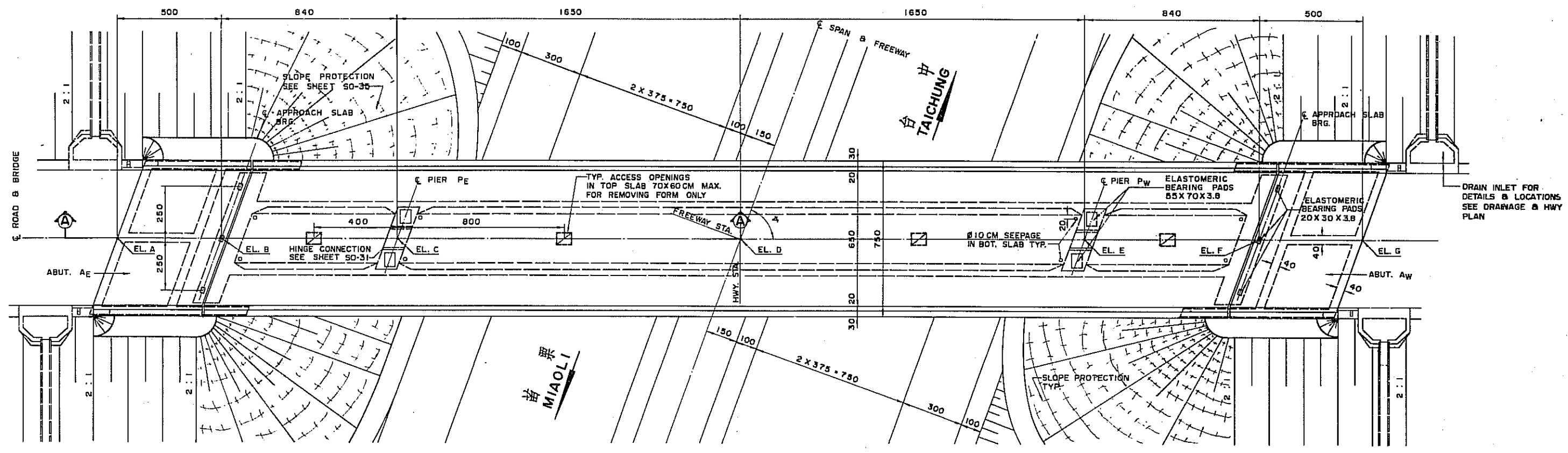

平面圖
PLAN

說明:

參閱圖表圖 SO-36.

NOTE:

FOR GENERAL NOTES SEE SHEET SO-36.

PR. NO.	STATION FREEWAY	STATION HIGHWAY	CROSS-ANGLE α	ELEVATIONS (ON TOP OF WEARING SURFACE)							ELEVATIONS		REMARKS
				A	B	C	D	E	F	G	M	N	
60	132 + 246.82	0 + 334.79	73°22'29"	182.803	182.890	183.005	183.109	183.055	182.967	182.895	180.320	180.420	[40]
62	140 + 357.22	0 + 355.53	83°07'57"	184.444	184.523	184.622	184.700	184.622	184.523	184.444	181.960	181.960	[81]

PROJECT 60

修正	REVISIONS	項目	ITEM	日期	DATE

交通部台灣區高速公路工程局
TAIWAN AREA FREEWAY CONSTRUCTION BUREAU
中華民國
REPUBLIC OF CHINA
南北高速公路
NORTH-SOUTH FREEWAY
苗栗台中段
MIAOLI-TAICHUNG SECTION
單線跨線橋 (132+246.82) 1-LANE OVERCROSSING
總平面圖
GENERAL PLAN
中華顧問工程司
CHINA ENGINEERING CONSULTANTS, INC.
日期 DATE AUG. '74 比例 SCALE 1:100 圖號 SHEET SO-7

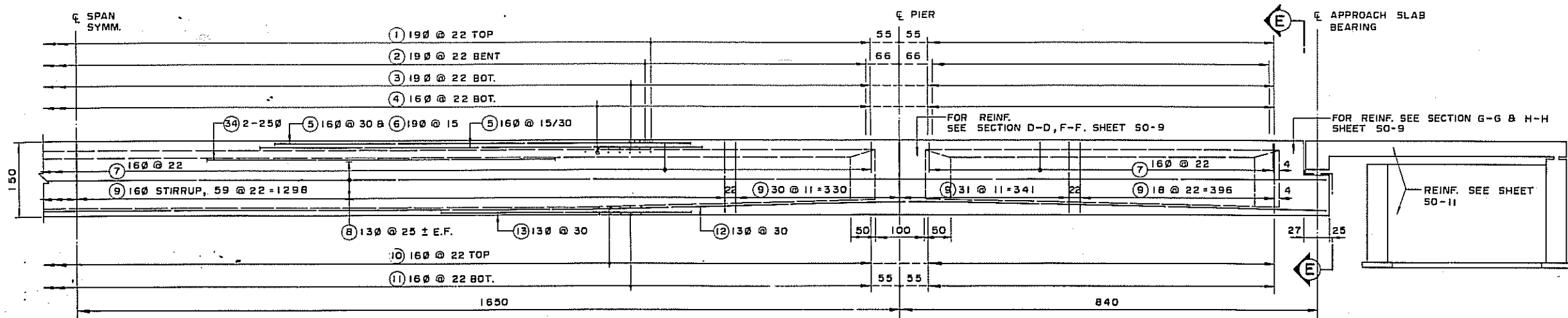

斷面圖 B-B
SECTION B-B
SCALE 1:50

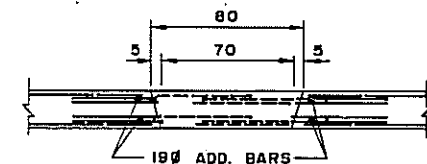

斷面圖 J-J
SECTION J-J

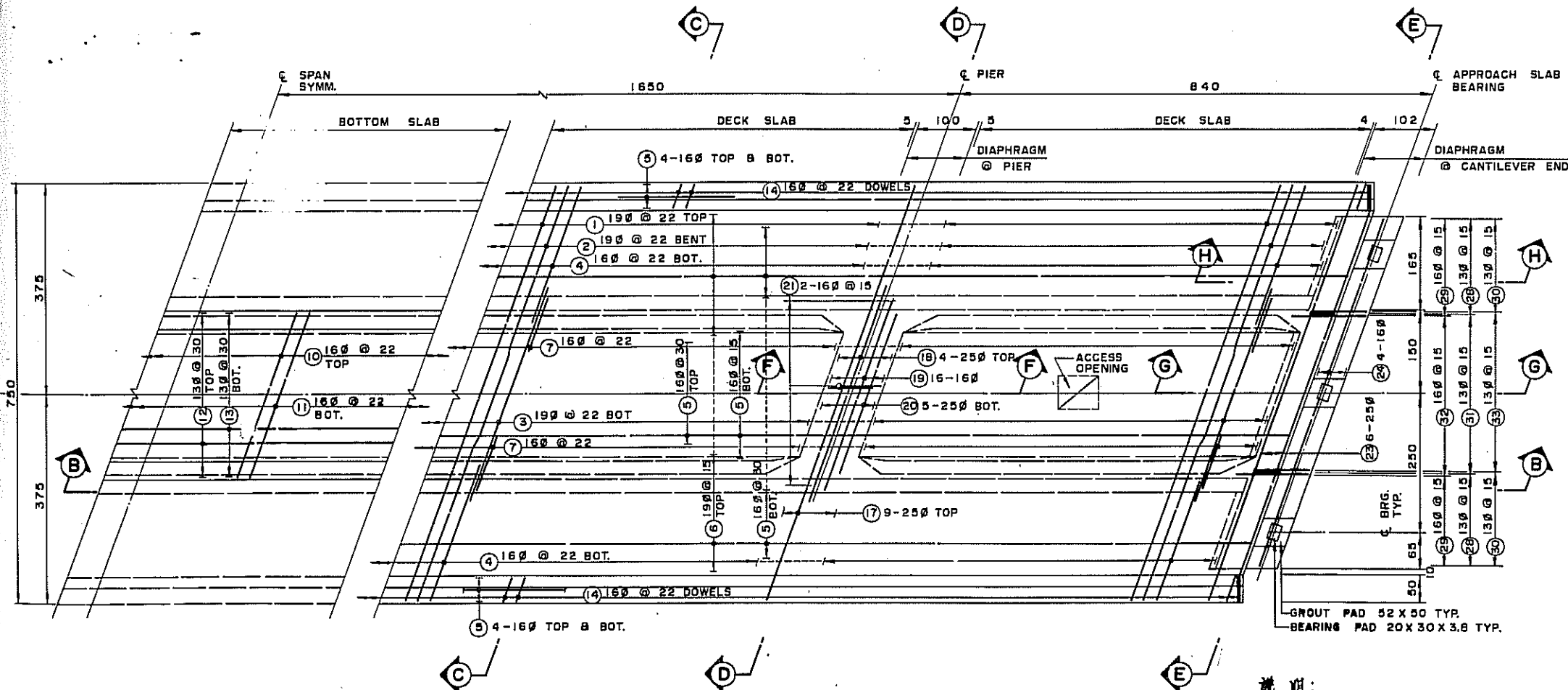

平面圖
PLAN
SCALE 1:50

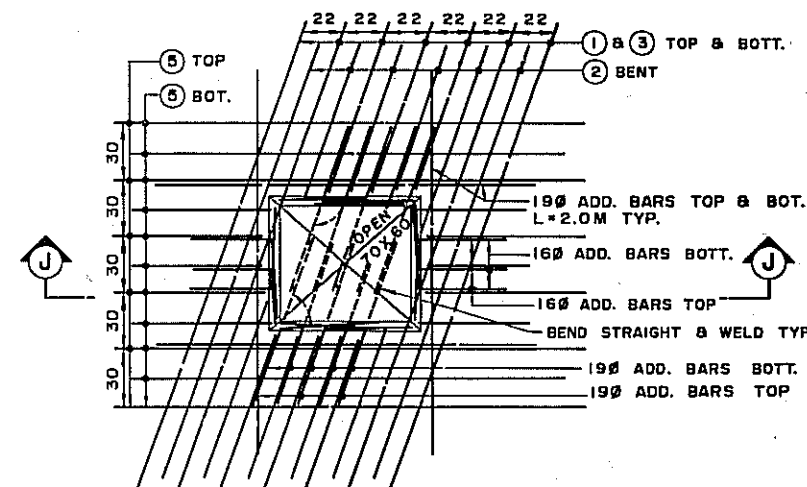

平面圖
PLAN
臨時孔道標準配筋圖
TYP. REINF. AT ACCESS OPENING
SCALE 1:20

說明:

視圖參照圖 SO-36。

NOTE:

FOR GENERAL NOTES SEE SHEET SO-36.

修正 REVISIONS	項目 ITEM	日期 DATE

交通部台灣區高速公路工程局
TAIWAN AREA FREEWAY CONSTRUCTION BUREAU
中華民國 REPUBLIC OF CHINA
南北高速公路 NORTH-SOUTH FREEWAY
苗栗台中段 MIAOLI-TAICHUNG SECTION
單線跨線橋 (132+246.82) I-LANE OVERCROSSING
上部結構鋼筋詳圖(I) SUPERSTR. REINF. DETAIL(I)
中華顧問工程司 CHINA ENGINEERING CONSULTANTS, INC.
日期 DATE AUG. '74 比例 SCALE AS SHOWN 圖號 SHEET SO-8

PROJECT 60

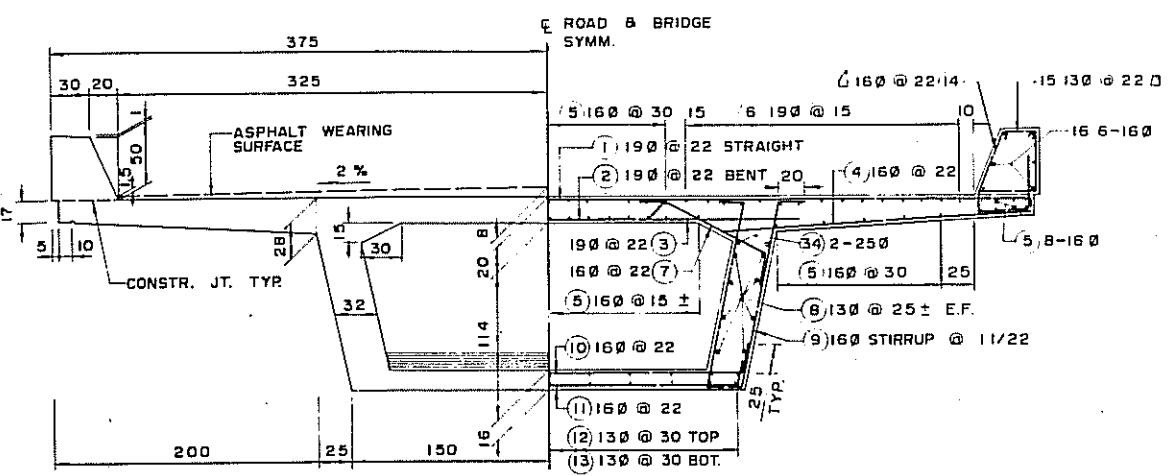

斷面圖 C-C
SECTION C-C
SCALE 1:30

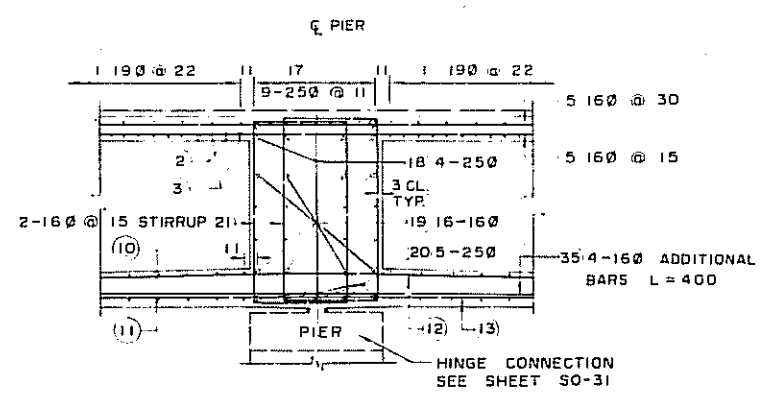

斷面圖 F-F
SECTION F-F
SCALE 1:30

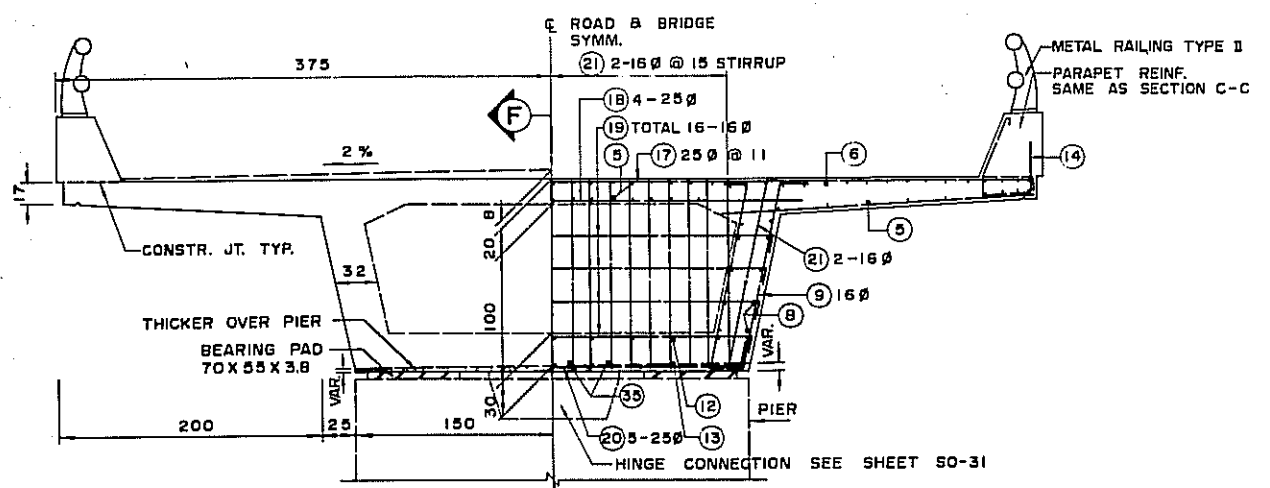

斷面圖 D-D
SECTION D-D
SCALE 1:30

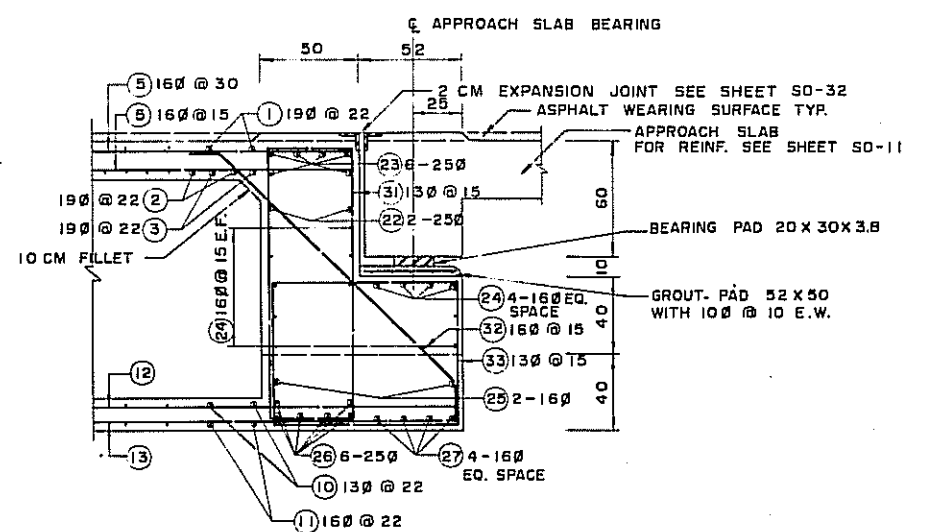

斷面圖 G-G
SECTION G-G
SCALE 1:20

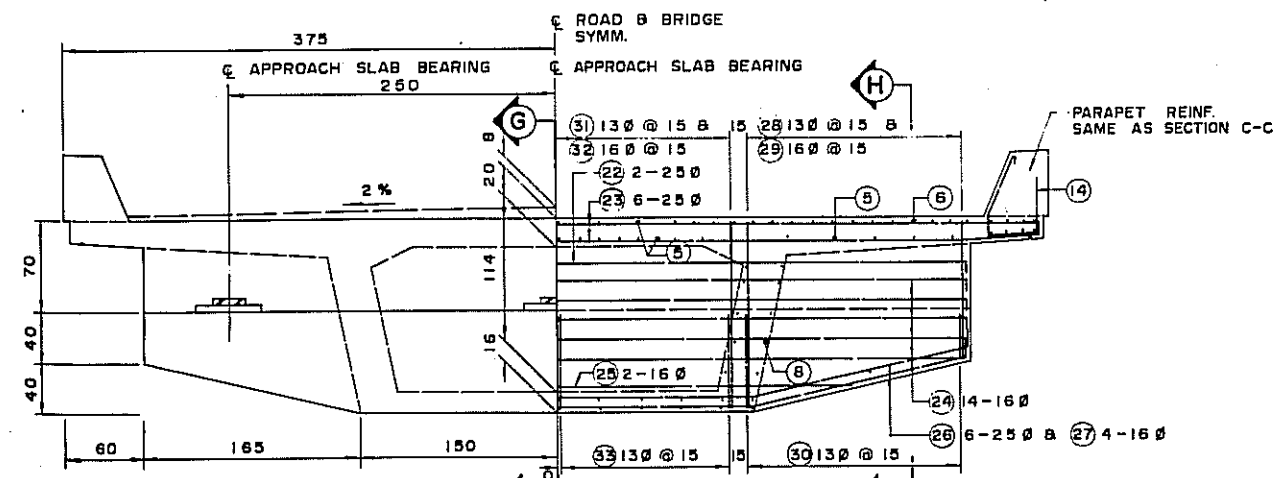

斷面圖 E-E
SECTION E-E
SCALE 1:30

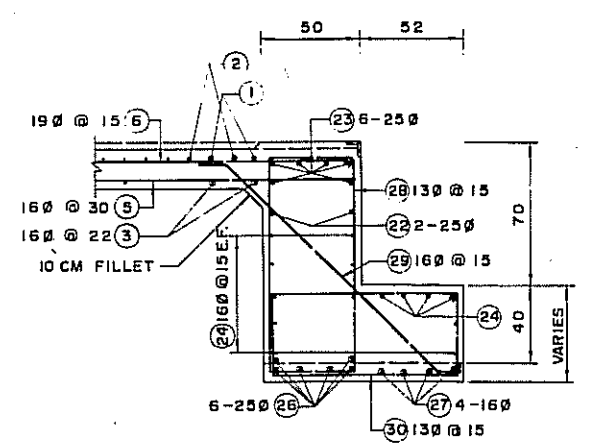

斷面圖 H-H
SECTION H-H
SCALE 1:20

鋼筋表
LIST OF REINFORCING STEELS

SHAPE	NOMINAL DIA. (MM)	REMARK
1	190	@ 22
2	190	@ 22
3	190	@ 22
4	160	@ 22
5	160	@ 15/30
6	190	@ 15/30
7	160	@ 22
8	130	
9	160	@ 11/22
10	160	@ 22
11	160	@ 22
12	130	@ 30
13	130	@ 30
14	160	@ 22
15	130	@ 22
16	160	
17	250	
18	250	
19	160	
20	250	
21	160	@ 15
22	250	
23	250	
24	160	@ 15
25	160	
26	250	
27	160	
28	130	@ 15
29	160	@ 15
30	130	@ 15
31	130	@ 15
32	160	@ 15
33	130	@ 15
34	250	
35	160	
36	100	BEHIND FREYSSH NET CONE ONLY

PROJECT 60

交通部台灣區高速公路工程局
TAIWAN AREA FREEWAY CONSTRUCTION BUREAU
中華民國
南北高速公路 NORTH-SOUTH FREEWAY
苗栗台中段 MIAOLI-TAICHUNG SECTION

單車道跨越橋(132+246.82) I-LANE OVERCROSSING
上部結構鋼筋詳圖(II) SUPERSTR. REINF. DETAIL(II)

中華顧問工程司 CHINA ENGINEERING CONSULTANTS, INC.
日期 DATE AUG. '74 比例 SCALE AS SHOWN 圖號 SHEET 50-9

修正 項目	REVISIONS ITEM	日期 DATE

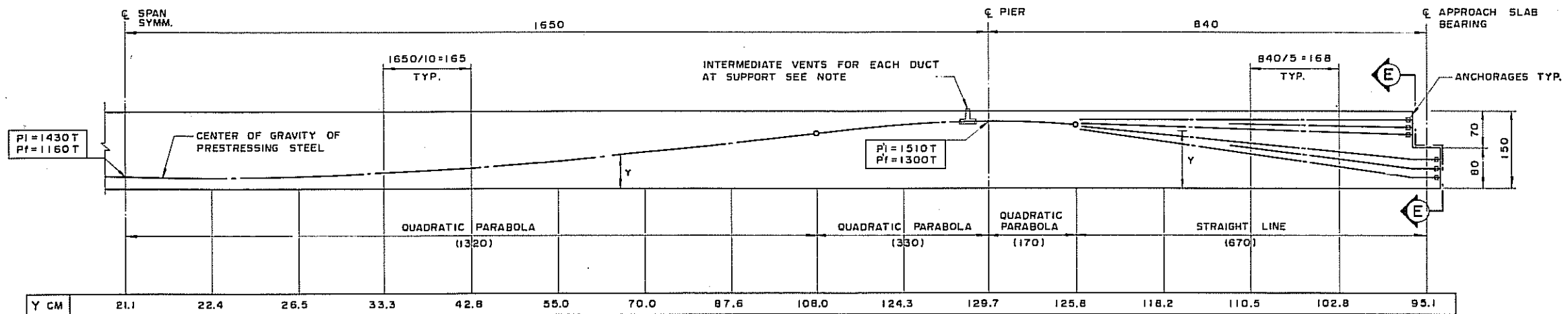

立面圖
ELEVATION
SCALE 1:50

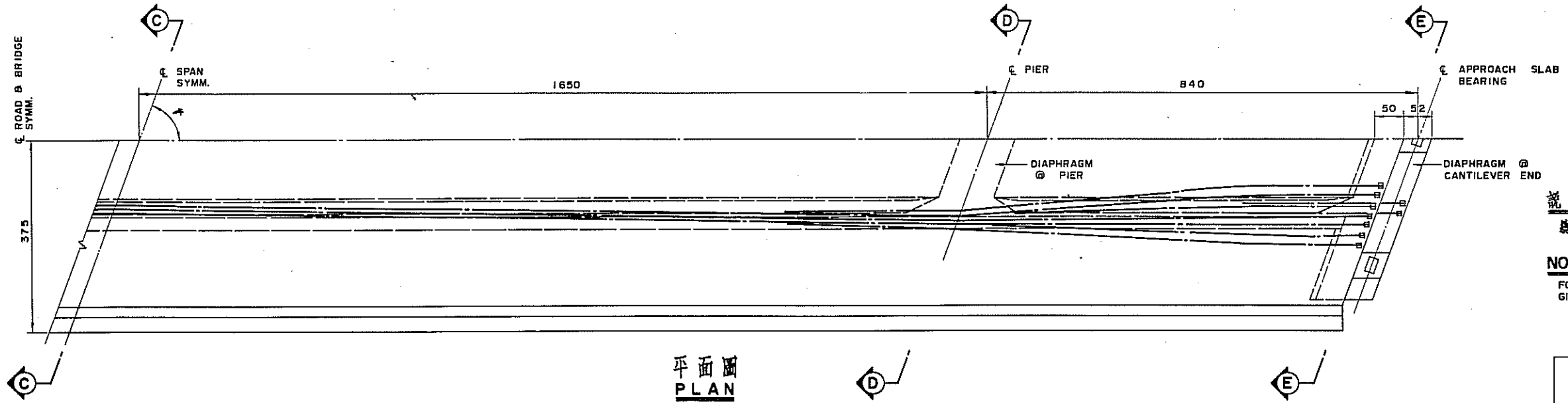

平面圖
PLAN
SCALE 1:50

說明:
應說明及預力混凝土橋樑參照圖 SO-36 -

NOTE:
FOR GENERAL NOTES & NOTES FOR P.C. BOX GIRDER SEE SHEET SO-36.

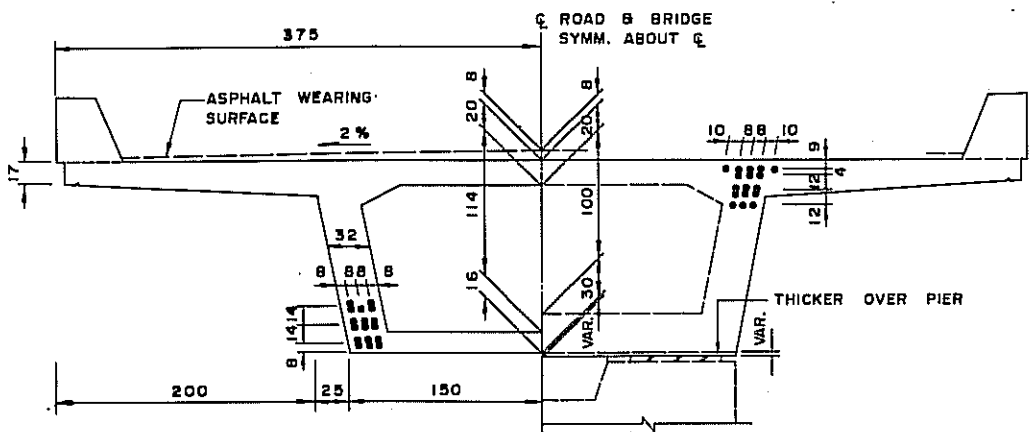

斷面圖 C-C
SECTION C-C
SCALE 1:30

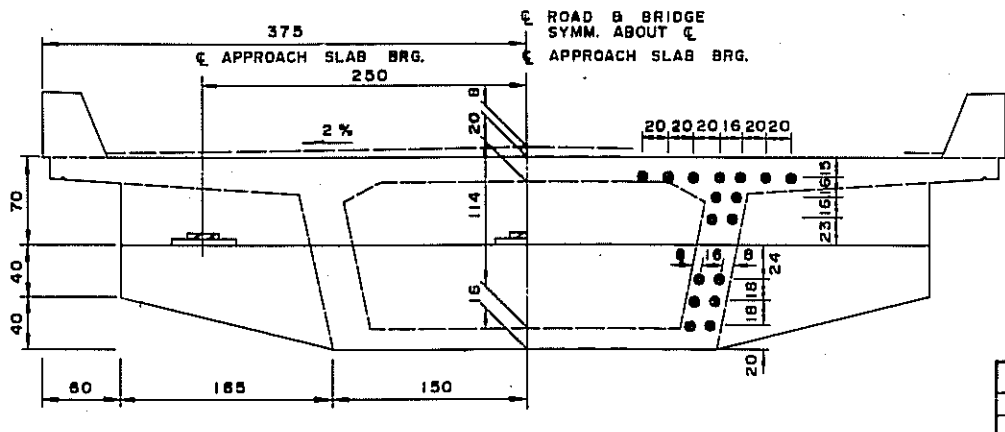

斷面圖 D-D
SECTION D-D
SCALE 1:30

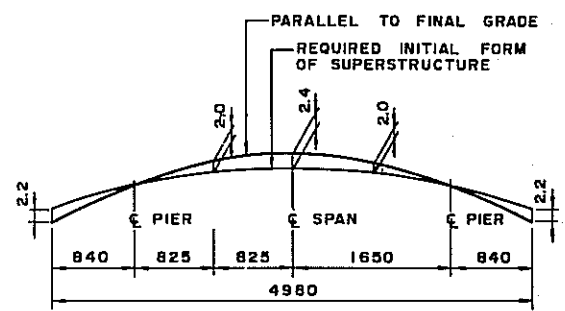

TOTAL DEAD LOAD + PRESTRESSED FORCE
撓度示意圖
DEFLECTION DIAGRAM
N.T.S.
(FOR REFERENCE ONLY)

斷面圖 E-E
SECTION E-E
SCALE 1:30

PROJECT 60

修正	REVISIONS	項目	ITEM	日期	DATE

交通部台灣區高速公路工程局
TAIWAN AREA FREEWAY CONSTRUCTION BUREAU
中華民國
REPUBLIC OF CHINA
南北高速公路 NORTH-SOUTH FREEWAY
苗栗台中段 MIAOLI-TAICHUNG SECTION
單車道跨越橋 (132+246.82) 1-LANE OVERCROSSING
鋼筋佈置詳圖 TENDON LAYOUT DETAILS
中華顧問工程司 CHINA ENGINEERING CONSULTANTS, INC.
日期 DATE AUG. '74 比例 SCALE AS SHOWN 圖號 SHEET SO-10

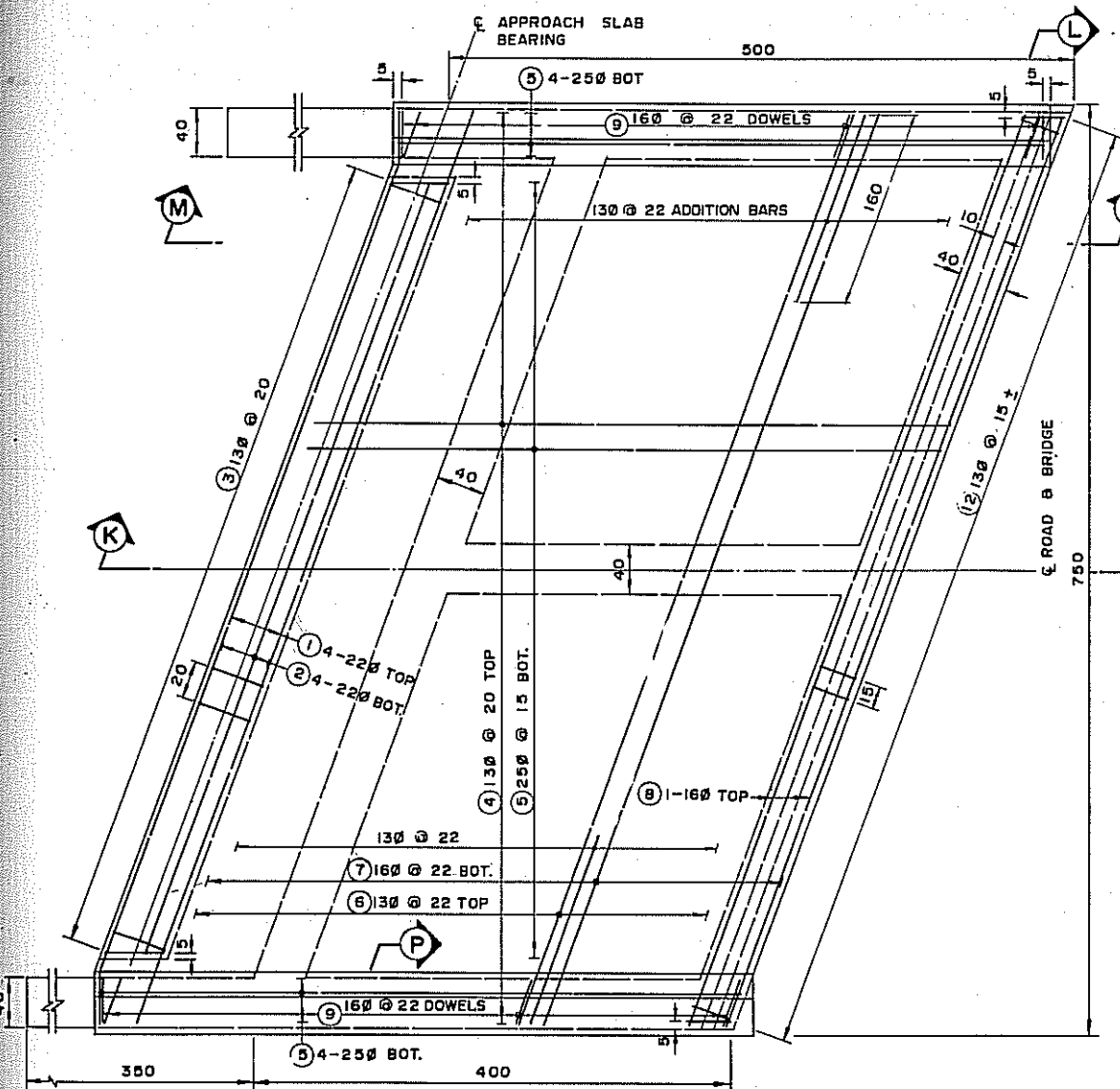

平面圖
PLAN
SCALE 1:30

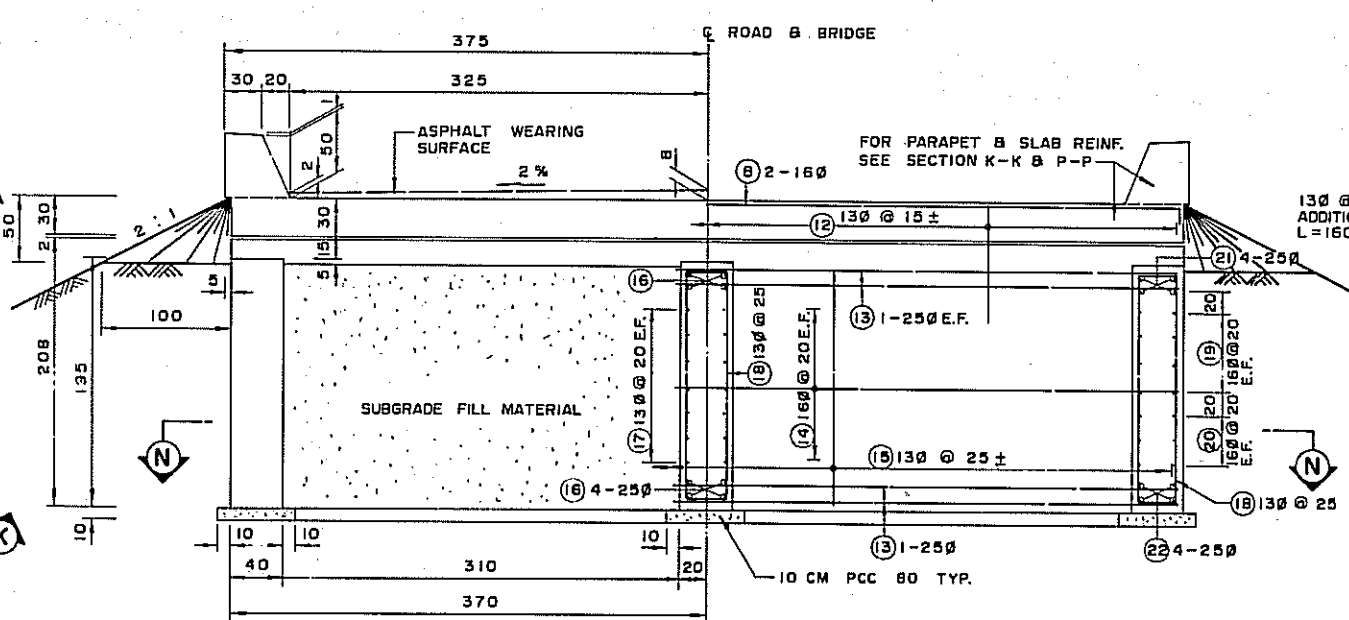

斷面圖 L-L
SECTION L-L
SCALE 1:30

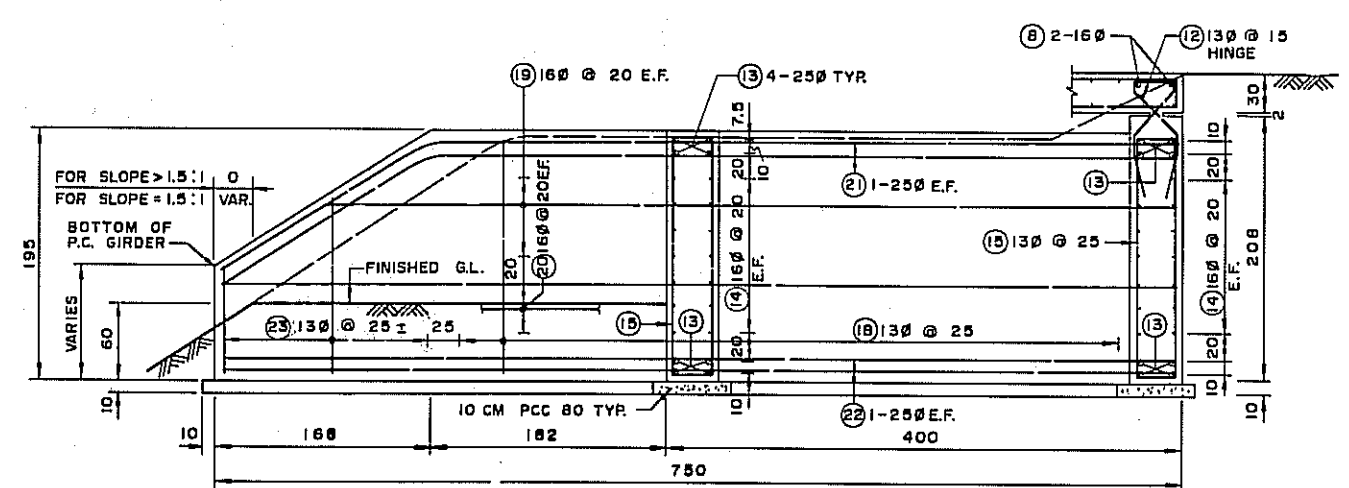

斷面圖 M-M
SECTION M-M
SCALE 1:30

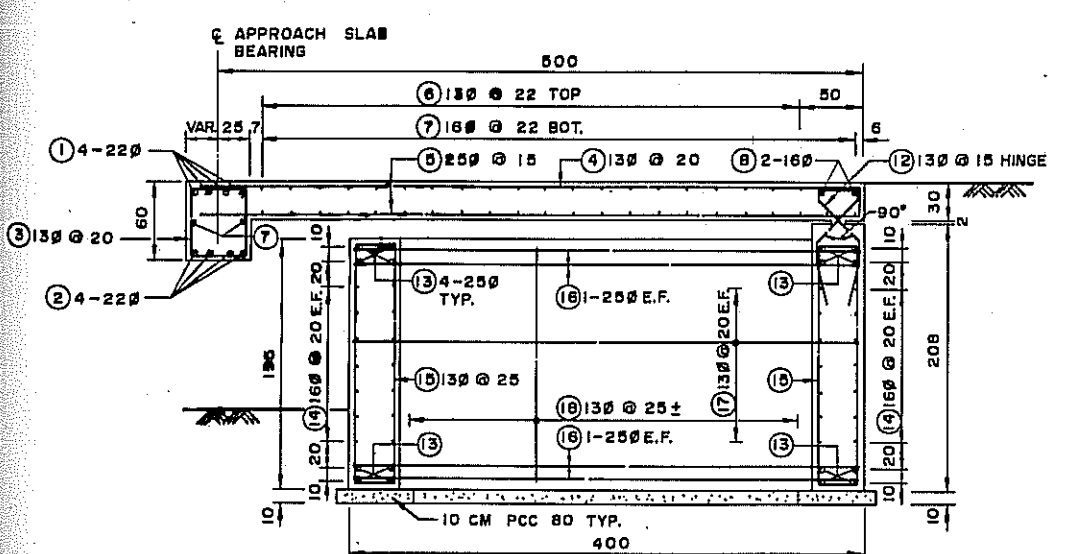

斷面圖 K-K
SECTION K-K
SCALE 1:30

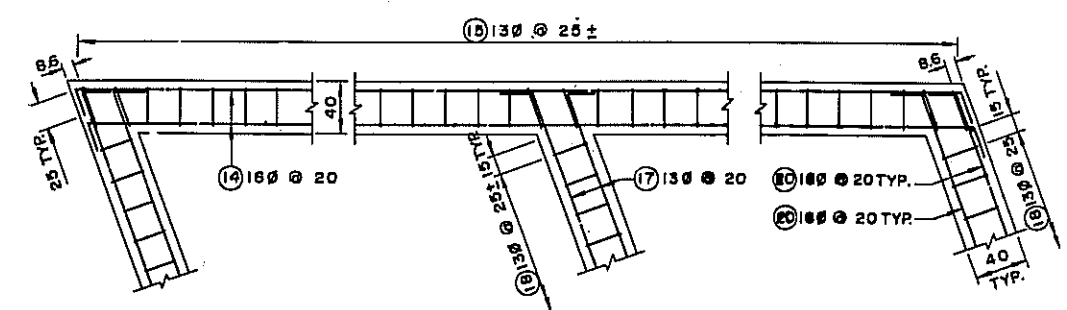

斷面圖 N-N
SECTION N-N
SCALE 1:30

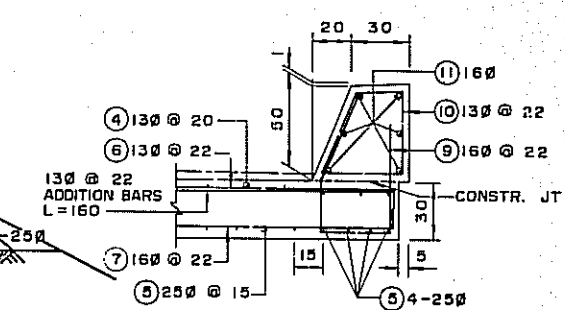

斷面圖 P-P
SECTION P-P
SCALE 1:20

鋼筋表
LIST OF REINFORCING STEELS

SHAPE	NOMINAL DIA.(MM)	REMARK
①	22Ø	
②	22Ø	
③	13Ø	@ 20
④	13Ø	@ 20
⑤	25Ø	@ 15
⑥	13Ø	@ 22
⑦	16Ø	@ 22
⑧	16Ø	
⑨	16Ø	@ 22
⑩	13Ø	@ 22
⑪	16Ø	
⑫	13Ø	@ 15
⑬	25Ø	
⑭	16Ø	@ 20
⑮	13Ø	@ 25
⑯	25Ø	
⑰	13Ø	@ 20
⑱	13Ø	@ 20
⑲	16Ø	@ 20
⑳	16Ø	@ 20
㉑	25Ø	
㉒	25Ø	
㉓	13Ø	L = VARIES

說明:

1. 應說明參照圖 SO-36.
2. 箱底填土須確實夯實.

NOTES:

1. FOR GENERAL NOTES SEE SHEET SO-36.
2. FILLING MATERIAL UNDER THE BOX SHOULD BE WELL COMPACTED.

修正 REVISIONS	項目 ITEM	日期 DATE

交通部台灣區高速公路工程局
TAIWAN AREA FREEWAY CONSTRUCTION BUREAU
中華民國
REPUBLIC OF CHINA
南北高速公路 NORTH-SOUTH FREEWAY
苗栗台中段 MIAOLI-TAICHUNG SECTION
單車道跨橋 (I32+246.82) 1-LANE OVERCROSSING
引道版及橋台鋼筋詳圖 APPROACH SLAB & ABUT. REINF. DETAILS
中華顧問工程司 CHINA ENGINEERING CONSULTANTS, INC.
日期 DATE AUG. '74 比例 SCALE AS SHOWN 圖號 SHEET SO-11

PROJECT 60

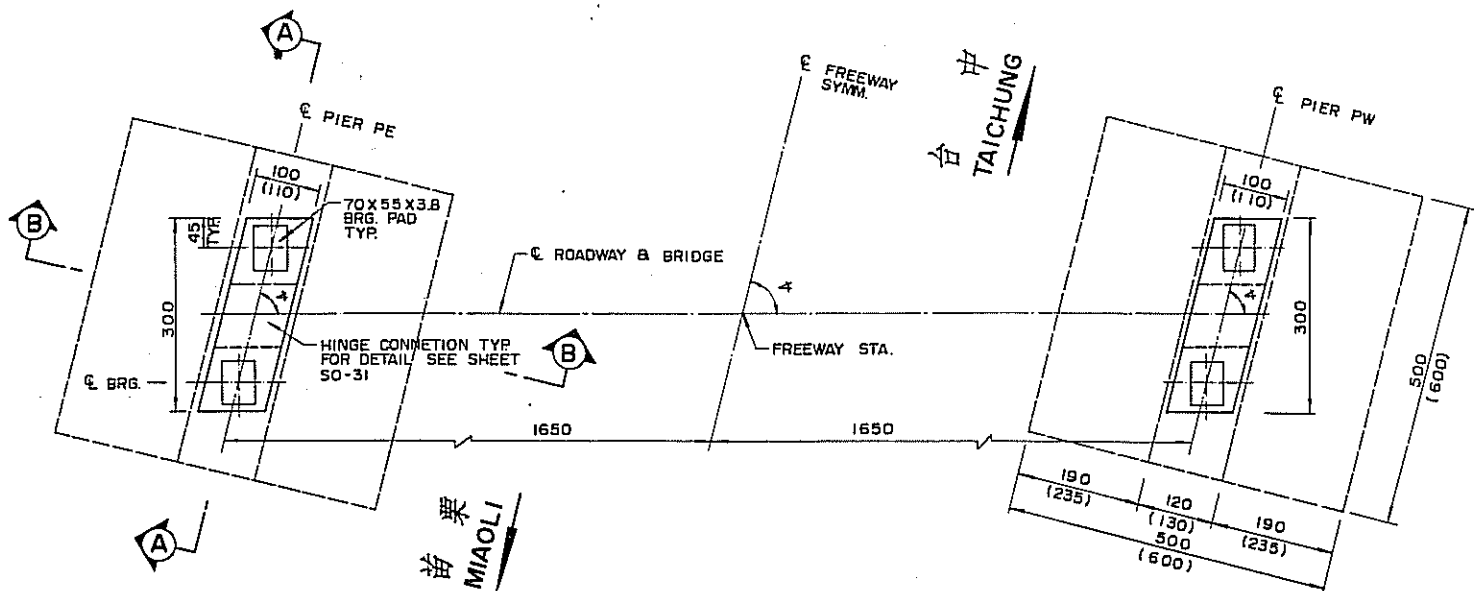

平面圖
PLAN
SCALE 1:60

NOTE: DIMENSIONS IN () ARE FOR TYPE I PIER ONLY.

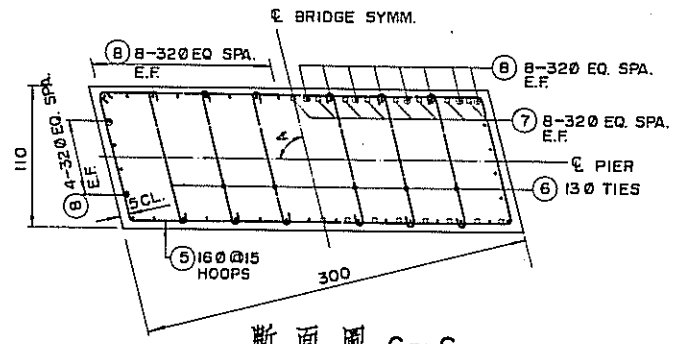

斷面圖 C-C
SECTION C-C
SCALE 1:30

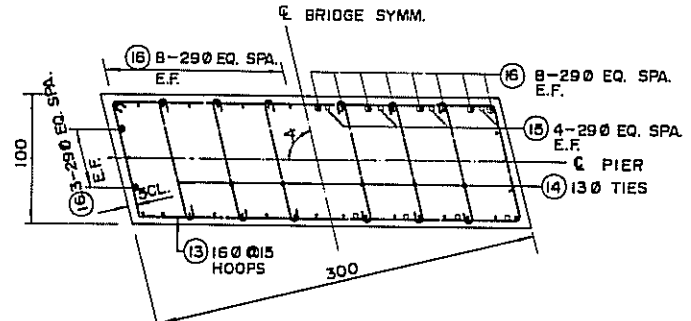

斷面圖 D-D
SECTION D-D
SCALE 1:30

鋼筋表
LIST OF REINFORCING STEELS

SHAPE	NOMINAL DIA. (MM)	REMARK
①	290	@ 15
②	190	@ 20
③	190	@ 18
④	160	
⑤	160	LENGTH VARIES
⑥	130	"
⑦	320	
⑧	320	LENGTH VARIES
⑨	290	@ 22
⑩	190	@ 22
⑪	190	@ 22
⑫	160	@ 44
⑬	160	LENGTH VARIES
⑭	130	"
⑮	290	
⑯	290	LENGTH VARIES

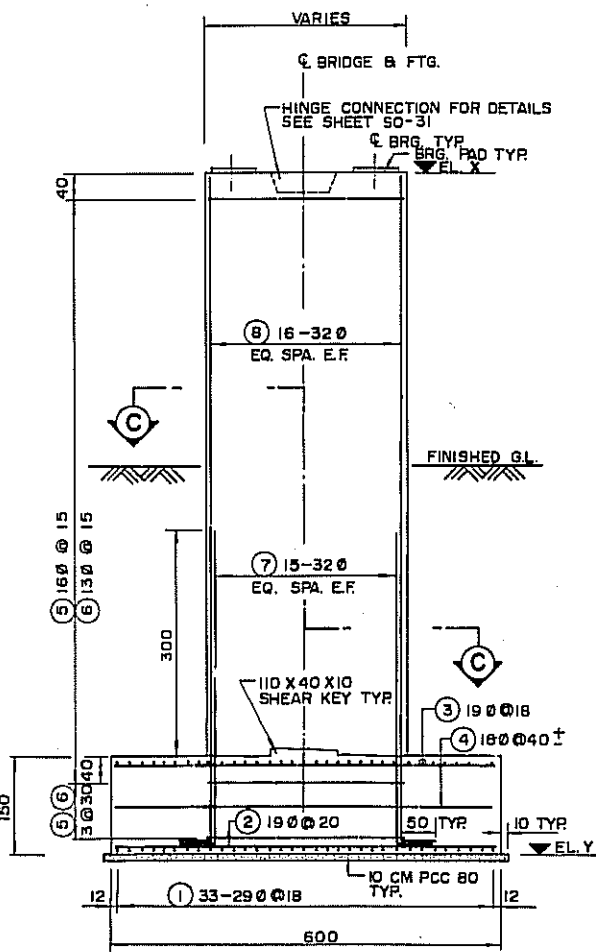

TYPE I

MAX. DESIGN FOUNDATION PRESSURE = 31 TONS/M²

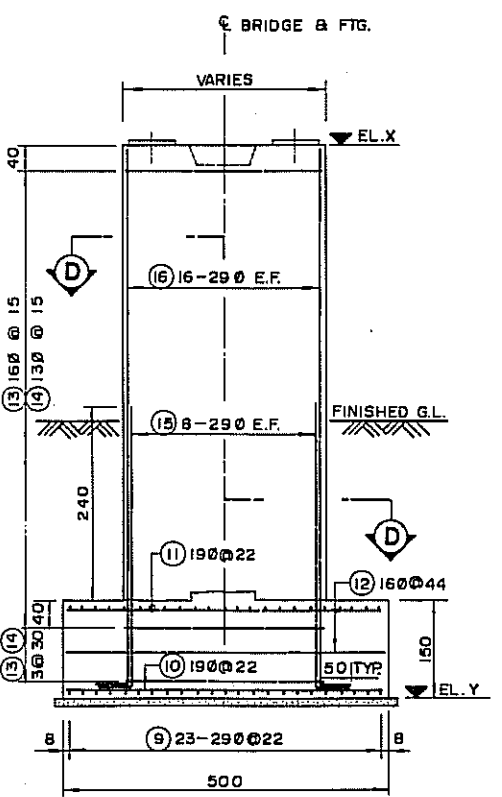

TYPE II

MAX. DESIGN FOUNDATION PRESSURE = 34 TONS/M²

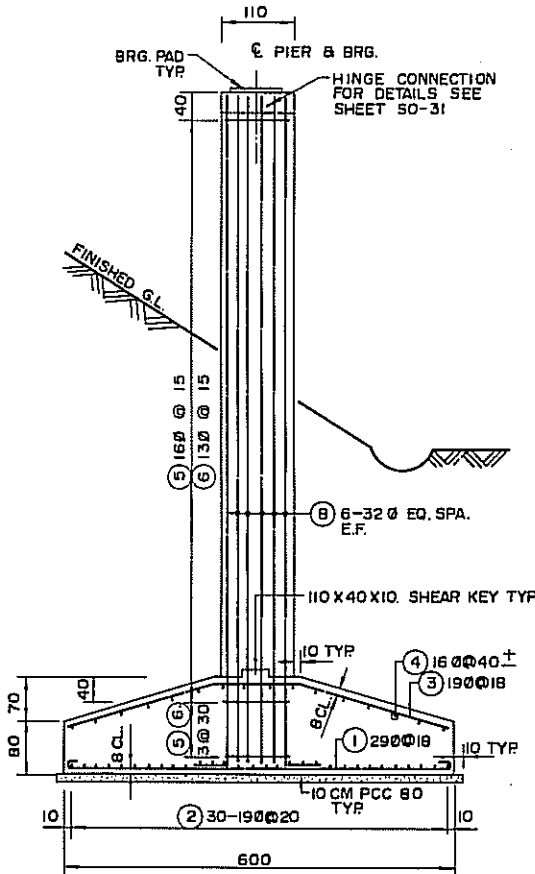

TYPE I

MAX. DESIGN FOUNDATION PRESSURE = 34 TONS/M²

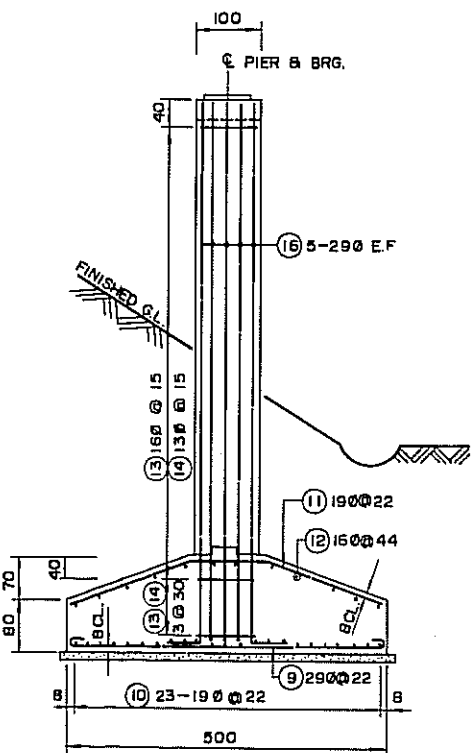

TYPE II

MAX. DESIGN FOUNDATION PRESSURE = 34 TONS/M²

高程表
LIST OF ELEVATIONS

STA. FREEWAY	CROSS ANGLE	PIER	TYPE	ELEVATIONS (M)	
				X	Y
132 + 246.82	73°22'29"	PE	I	181.360	171.400
		PW	I	181.410	171.400
140 + 357.22	83°07'59"	PE	II	182.980	174.700
		PW	II	182.980	174.700

說明:
詳說明參照圖 SO-36.

NOTE:
FOR GENERAL NOTES SEE SHEET SO-36.

PROJECT 60

修正 REVISIONS	項目 ITEM	日期 DATE

交通部台灣區高速公路工程局
TAIWAN AREA FREEWAY CONSTRUCTION BUREAU
中華民國
REPUBLIC OF CHINA
南北高速公路 NORTH-SOUTH FREEWAY
苗栗台中段 MIAOLI-TAICHUNG SECTION
單車道跨橋 (132+246.82) 1-LANE OVERCROSSING
橋墩鋼筋詳圖 PIER REINF. DETAILS
中華顧問工程司 CHINA ENGINEERING CONSULTANTS, INC.
日期 DATE AUG. '74 比例 SCALE AS SHOWN 圖號 SHEET SO-12

斷面圖 A-A
SECTION A-A
SCALE 1:60

斷面圖 B-B
SECTION B-B
SCALE 1:60

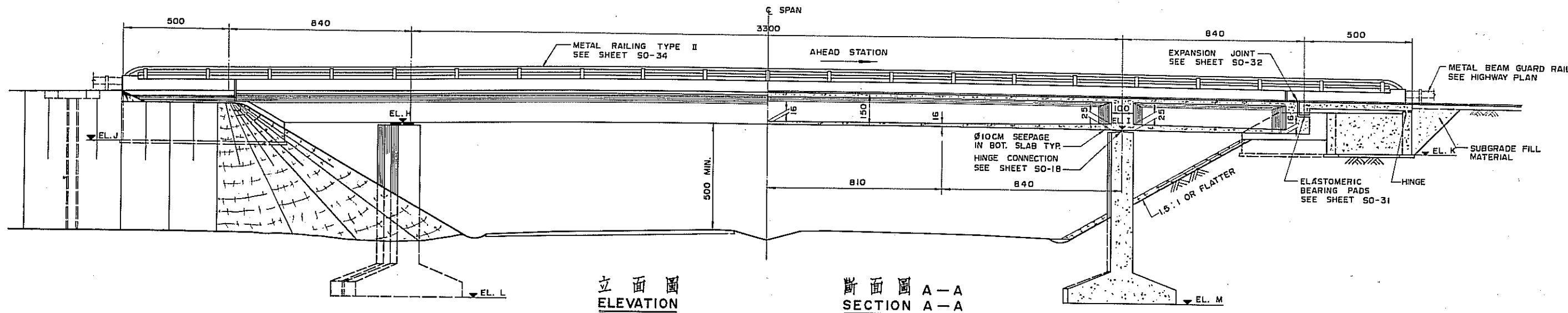

立面圖
ELEVATION

斷面圖 A-A
SECTION A-A

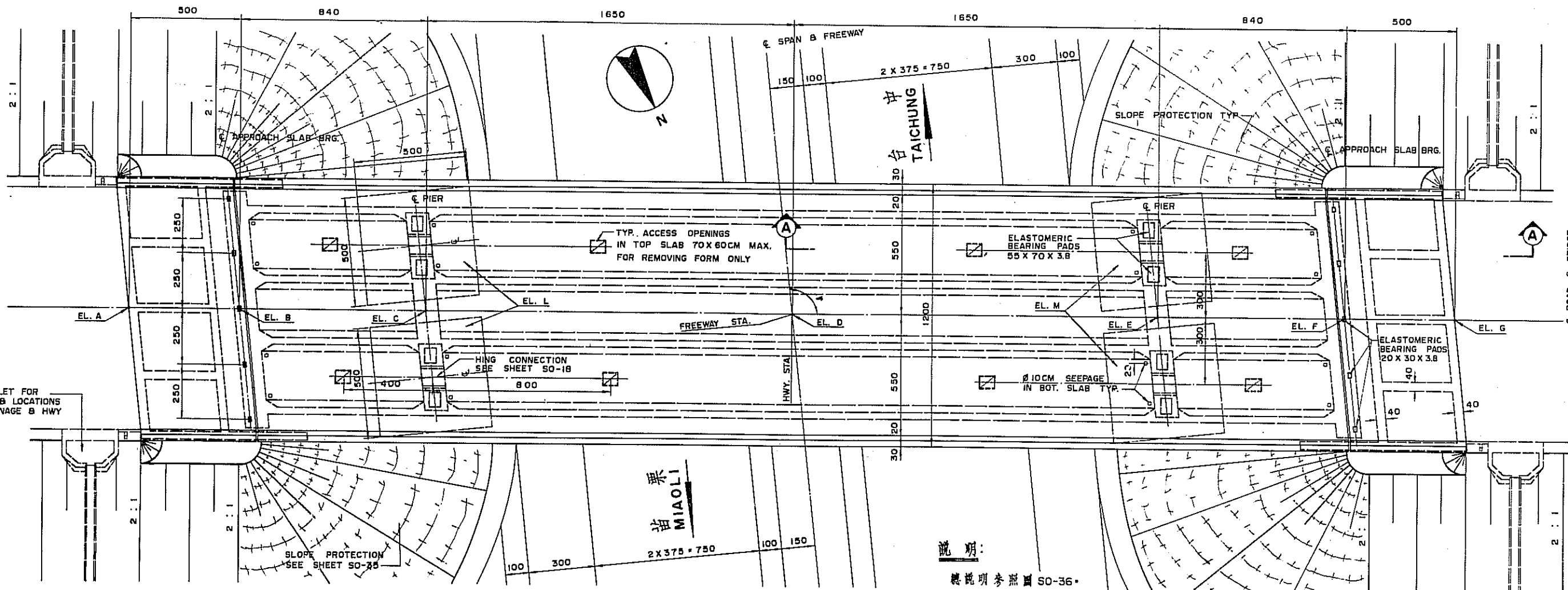

平面圖
PLAN

說明:
總說明參照圖 SO-36.

NOTE:
FOR GENERAL NOTES SEE SHEET SO-36.

PROJECT 60

PR. NO.	STATION FREEWAY	STATION HIGHWAY	CROSS-ANGLE	ELEVATIONS (ON TOP OF WEARING SURFACE)							ELEVATIONS							REMARKS
				A	B	C	D	E	F	G	**H	**I	J	K	L	M	**EL. ON TOP OF BRG. PAD	
60	136 + 177.38	0 + 304.45	99° 57' 48"	205.402	205.428	205.449	205.408	205.258	205.140	205.057	203.808	203.602	202.83	202.48	195.170	194.96	36	

修正	REVISIONS
項目	ITEM
日期	DATE

交通部台灣區高速公路工程局
TAIWAN AREA FREEWAY CONSTRUCTION BUREAU
中華民國
REPUBLIC OF CHINA
南北高速公路
NORTH-SOUTH FREEWAY
苗栗台中段
MIAOLI-TAICHUNG SECTION
雙車道跨線橋 (136+177.38) 2-LANE OVERCROSSING
橋平面圖
GENERAL PLAN
中華顧問工程司
CHINA ENGINEERING CONSULTANTS, INC.
日期 DATE AUG. '74 比例 SCALE 1:100 圖號 SHEET. SO-13

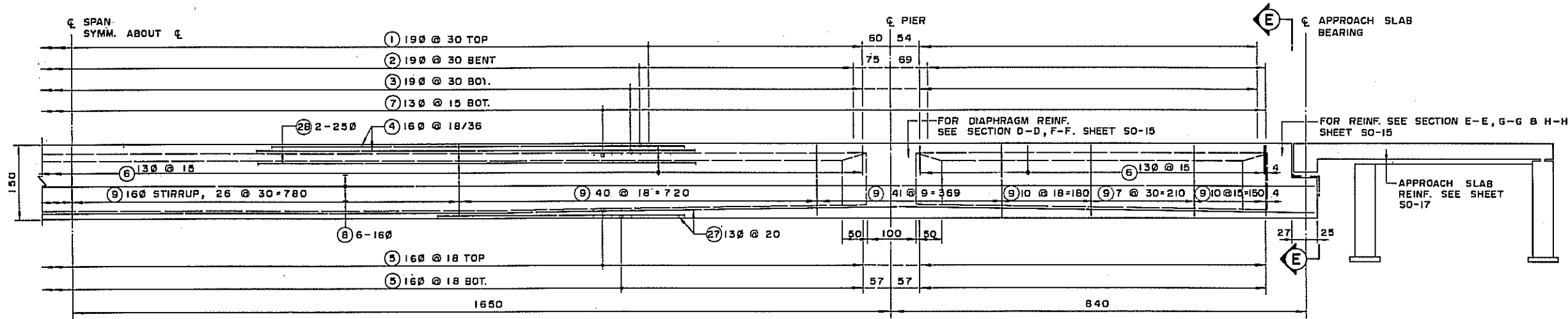

斷面圖 B-B
SECTION B-B
SCALE 1:50

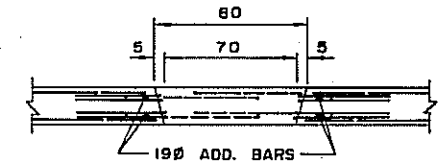

斷面圖 J-J
SECTION J-J

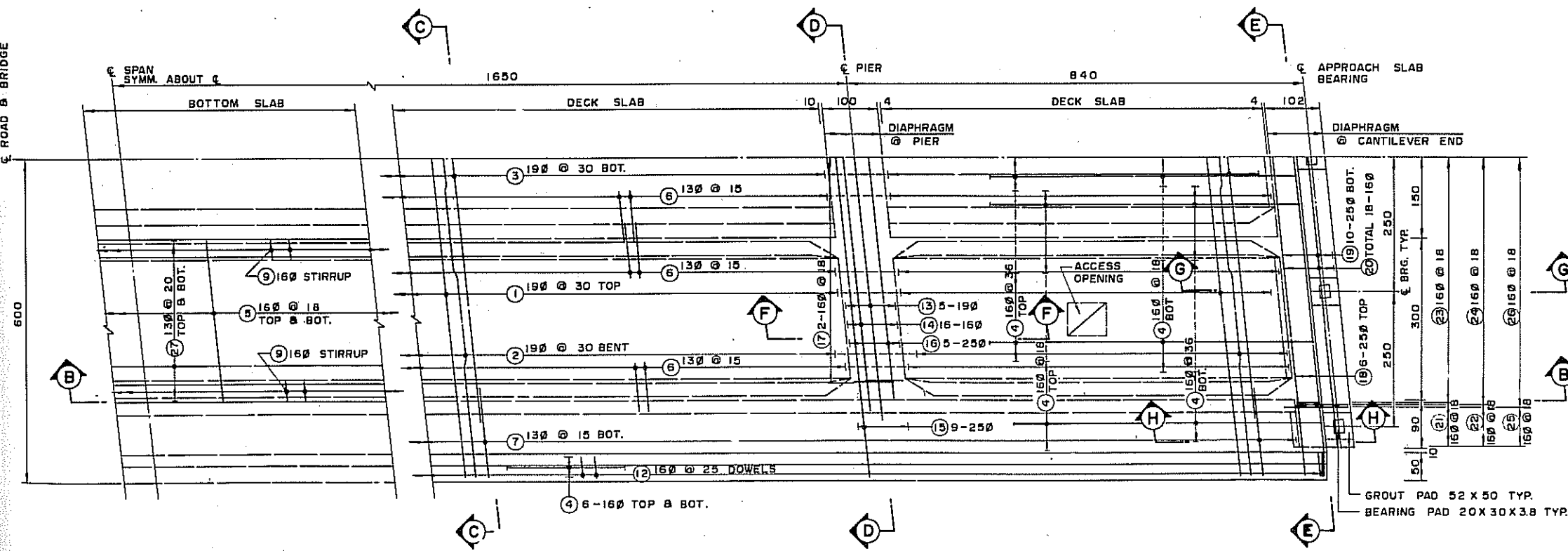

平面圖
PLAN
SCALE 1:50

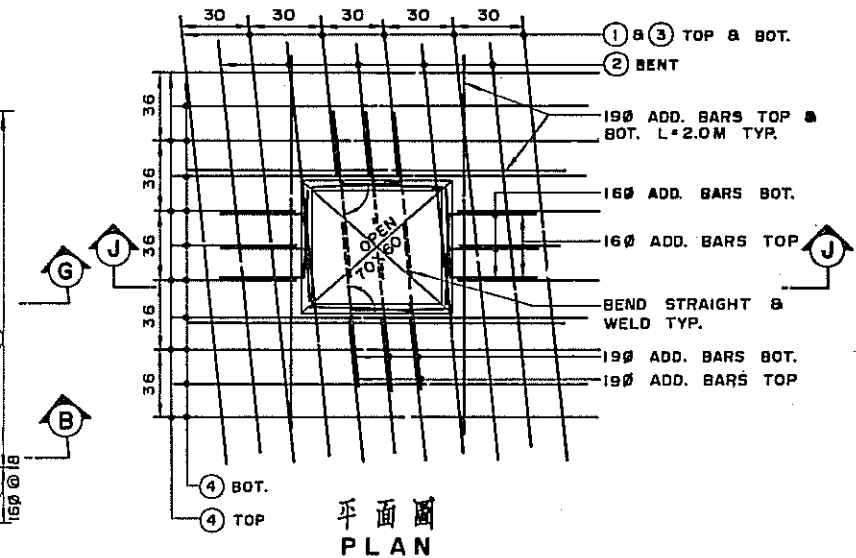

臨時孔道標準配筋圖
TYP. REINF. AT ACCESS OPENING
SCALE 1:20

說明:

總說明參照圖 SO-36。

NOTE:

FOR GENERAL NOTES SEE SHEET SO-36.

REVISIONS		PROJECT 60	
序號	REVISIONS	項目	日期 DATE

交通部台灣區高速公路工程局
TAIWAN AREA FREEWAY CONSTRUCTION BUREAU
中華民國
REPUBLIC OF CHINA
南北高速公路 NORTH-SOUTH FREEWAY
苗栗台中段 MIAOLI-TAICHUNG SECTION
雙車道跨線橋 (136+177.38) 2-LANE OVERCROSSING
上部結構鋼筋詳圖(1) SUPERSTR. REINF. DETAIL(1)
中華顧問工程司 CHINA ENGINEERING CONSULTANTS, INC.
日期 DATE AUG. '74 比例 SCALE AS SHOWN 圖號 SHEET SO-14

鋼筋表
LIST OF REINFORCING STEELS

SHAPE	NOMINAL DIA. (MM)	REMARK
①	19φ	@ 30
②	19φ	@ 30
③	19φ	@ 30
④	16φ	@ 18/36
⑤	16φ	@ 18
⑥	13φ	@ 15
⑦	13φ	@ 15
⑧	16φ	
⑨	16φ	
⑩	13φ	@ 25
⑪	16φ	
⑫	16φ	@ 25
⑬	19φ	
⑭	16φ	
⑮	25φ	
⑯	25φ	
⑰	16φ	@ 18
⑱	25φ	
⑳	16φ	
㉑	16φ	VARIES SHAPE
㉒	16φ	VARIES SHAPE
㉓	16φ	@ 18
㉔	16φ	@ 18
㉕	16φ	VARIES SHAPE
㉖	16φ	@ 18
㉗	13φ	@ 20
㉘	25φ	
㉙	16φ	
㉚	10φ	BEHIND FREYSSH NET CONE ONLY

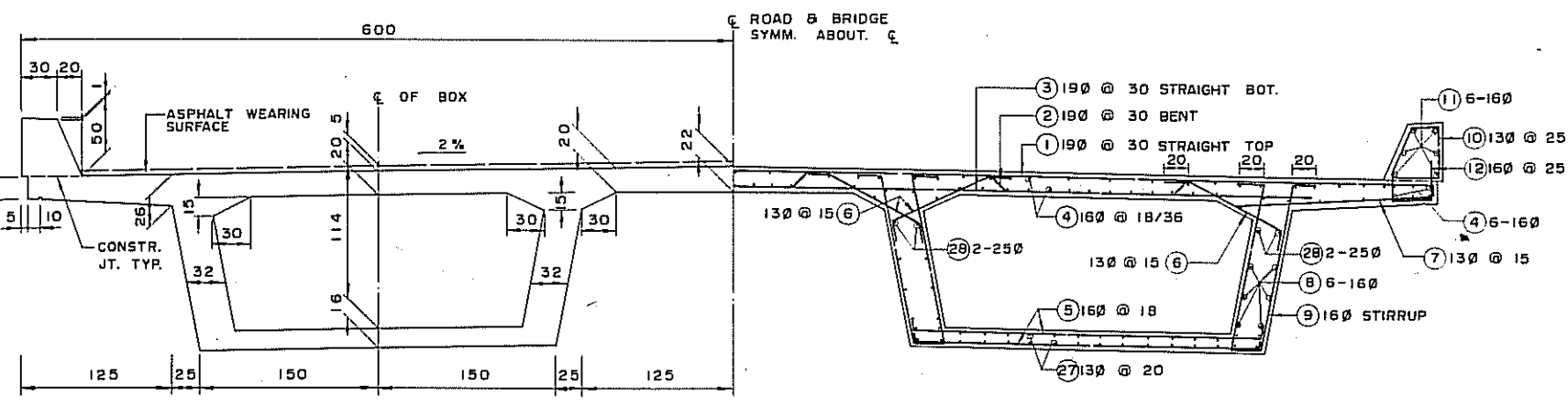

斷面圖 C—C
SECTION C—C
SCALE 1:30

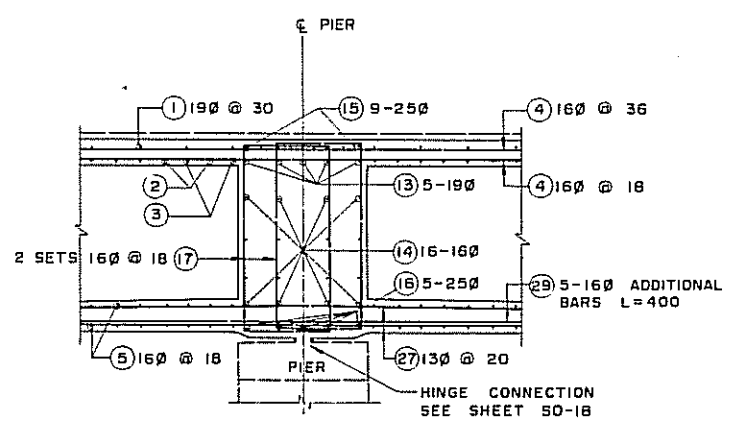

斷面圖 F—F
SECTION F—F
SCALE 1:30

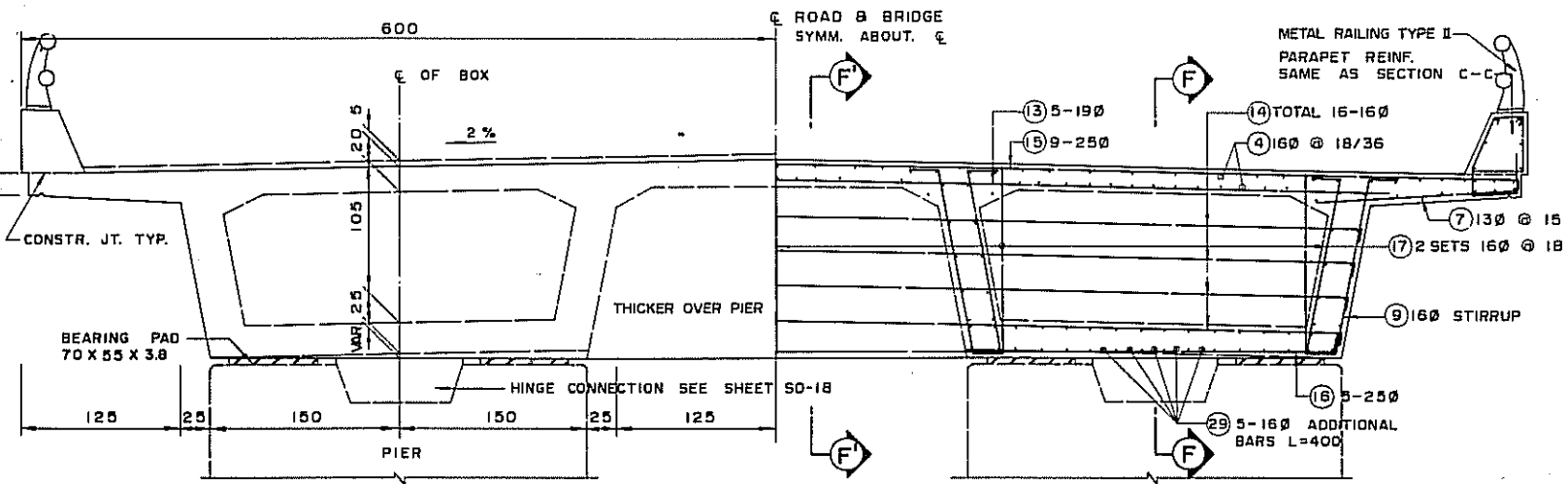

斷面圖 D—D
SECTION D—D
SCALE 1:30

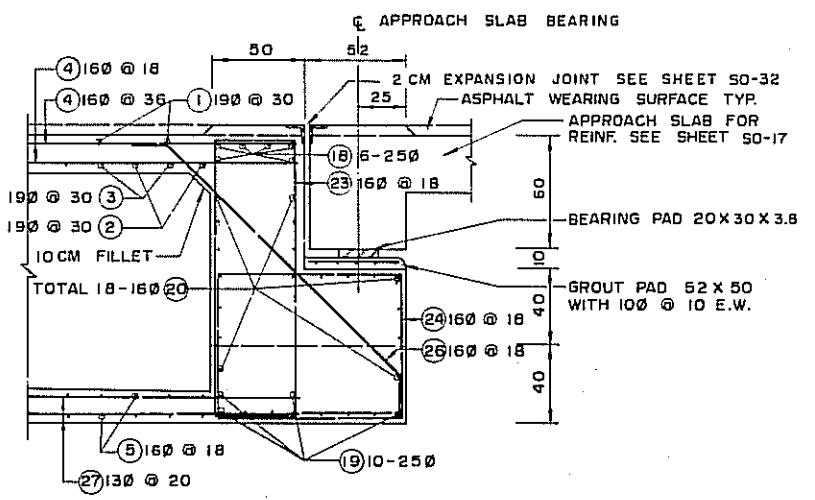

斷面圖 G—G
SECTION G—G
SCALE 1:20

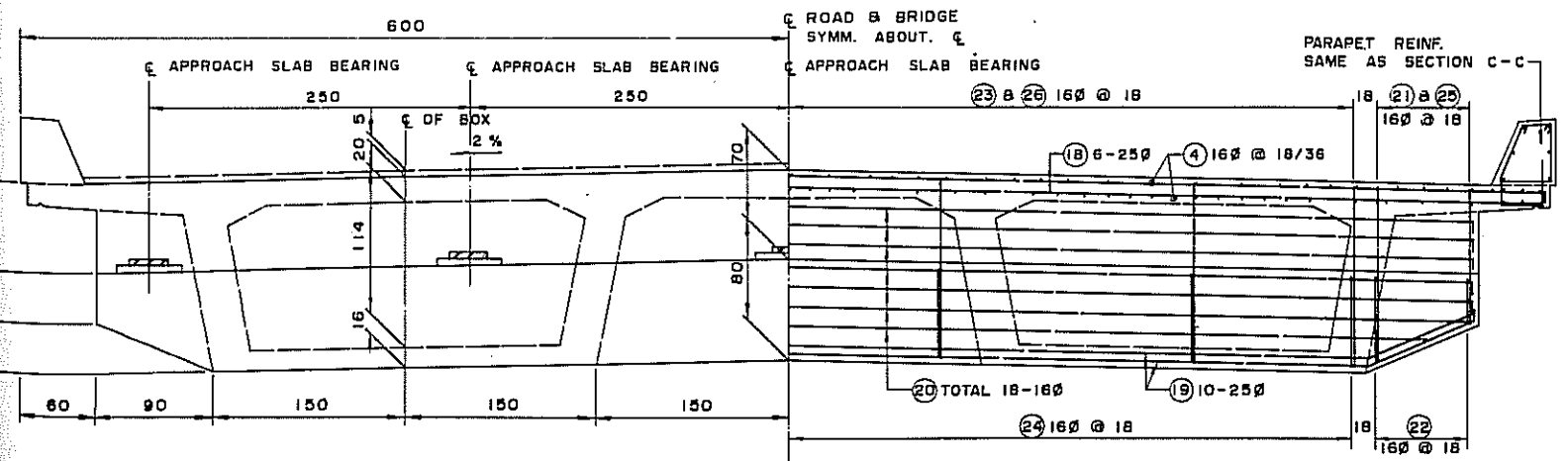

斷面圖 E—E
SECTION E—E
SCALE 1:30

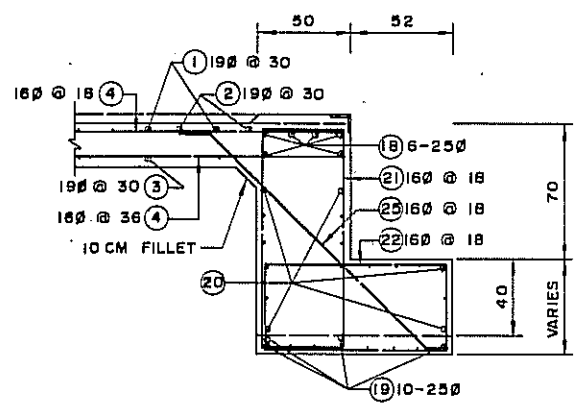

斷面圖 H—H
SECTION H—H
SCALE 1:20

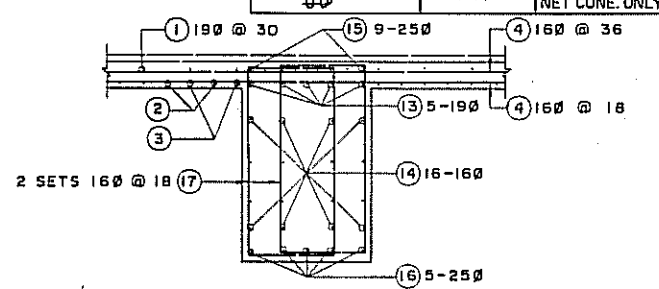

斷面圖 F'—F'
SECTION F'—F'
SCALE 1:30

PROJECT 60

交通部台灣區高速公路工程局
TAIWAN AREA FREEWAY CONSTRUCTION BUREAU
中華民國
REPUBLIC OF CHINA

南北高速公路
苗栗台中段
NORTH-SOUTH FREEWAY
MIAOLI-TAICHUNG SECTION

雙車道地橋(136.177.38)
上部結構鋼筋詳圖(II)
2-LANE OVERCROSSING
SUPERSTR. REINF. DETAIL (II)

中華顧問工程司
CHINA ENGINEERING CONSULTANTS, INC.

日期 DATE AUG. '74 比例 SCALE AS SHOWN 圖號 SHEET SO-15

修正	REVISIONS
項目	ITEM
日期	DATE

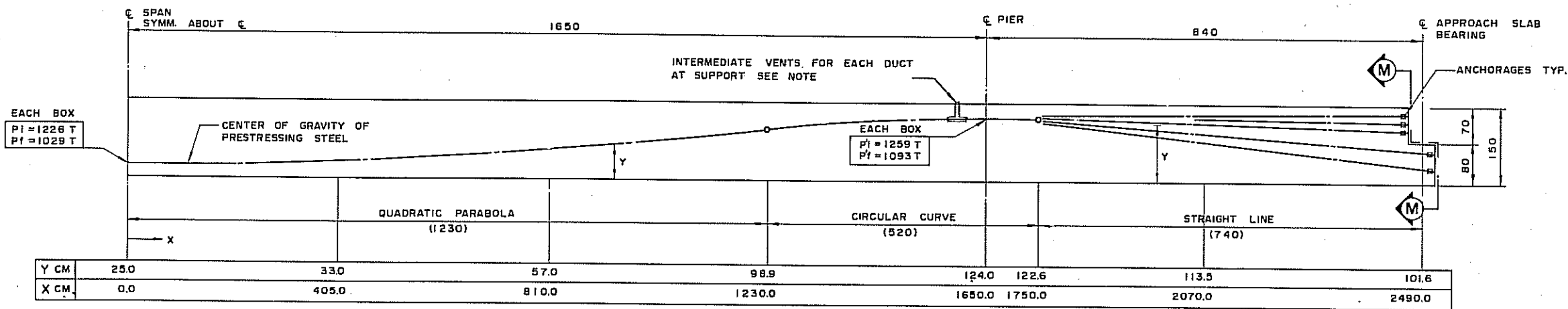

斷面圖 K-K
SECTION K-K
SCALE 1:50

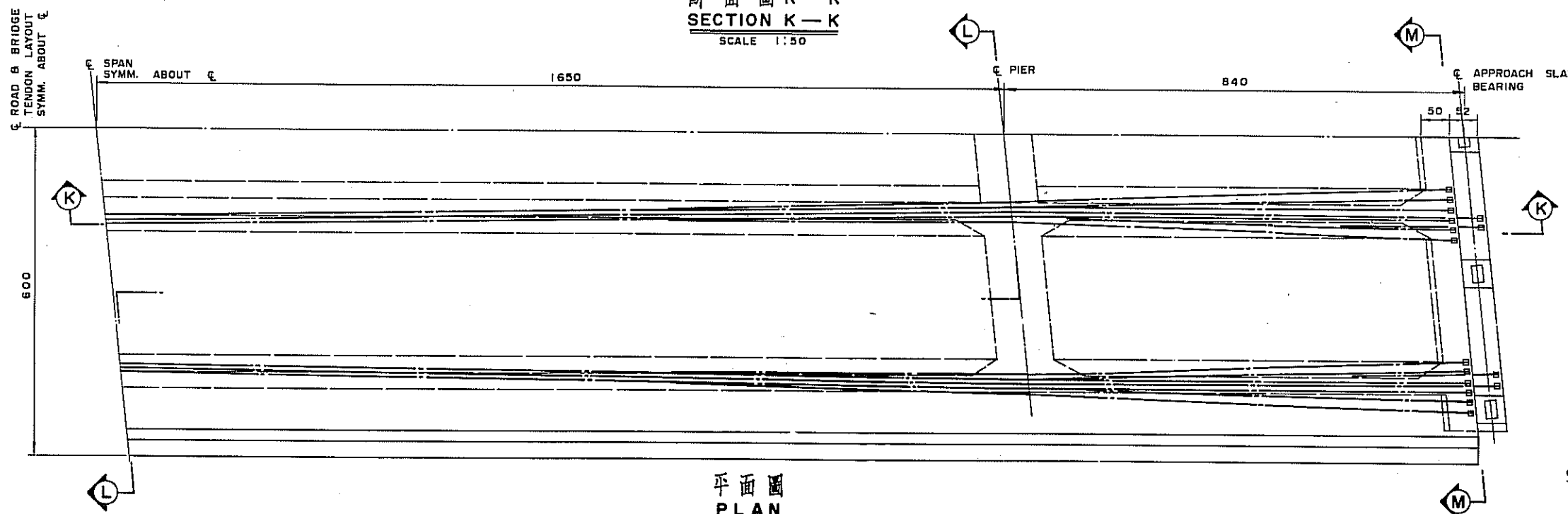

平面圖
PLAN
SCALE 1:50

說明:

總說明及預力混凝土箱樑說明參照圖 SO-36。

NOTE:

FOR GENERAL NOTES & NOTES FOR P.C. BOX GIRDER SEE SHEET SO-36.

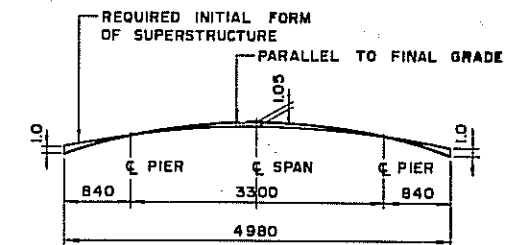

TOTAL DEAD LOAD + PRESTRESSED FORCE

撓度示意圖
DEFLECTION DIAGRAM
N.T.S.

(FOR REFERENCE ONLY).

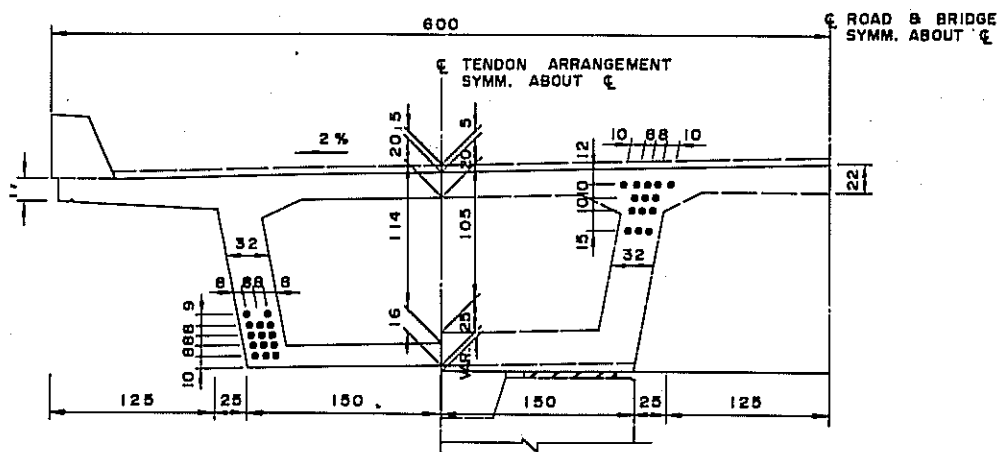

斷面圖 L-L
SECTION L-L
SCALE 1:30

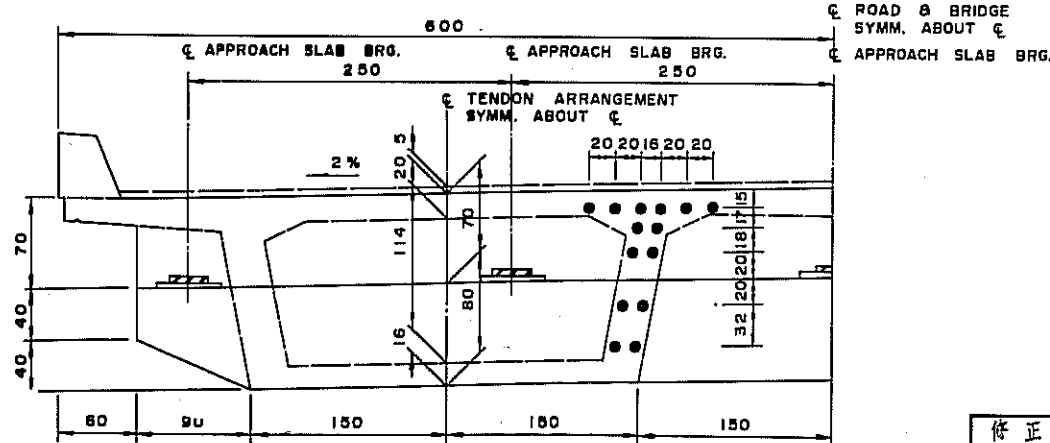

斷面圖 M-M
SECTION M-M
SCALE 1:30

PROJECT 60

修正 REVISIONS	項目 ITEM	日期 DATE	文通部台灣區高速公路工程局 TAIWAN AREA FREEWAY CONSTRUCTION BUREAU 中華民國 REPUBLIC OF CHINA
			南北高速公路 NORTH-SOUTH FREEWAY 苗栗台中段 MIAOLI-TAICHUNG SECTION
			雙車道橋樑 (136+177.38) 2-LANE OVERCROSSING 鋼絞佈置詳圖 TENDON LAYOUT DETAILS
			中華顧問工程司 CHINA ENGINEERING CONSULTANTS, INC.
			日期 DATE AUG. '74 比例 SCALE AS SHOWN 圖號 SHEET SO-16

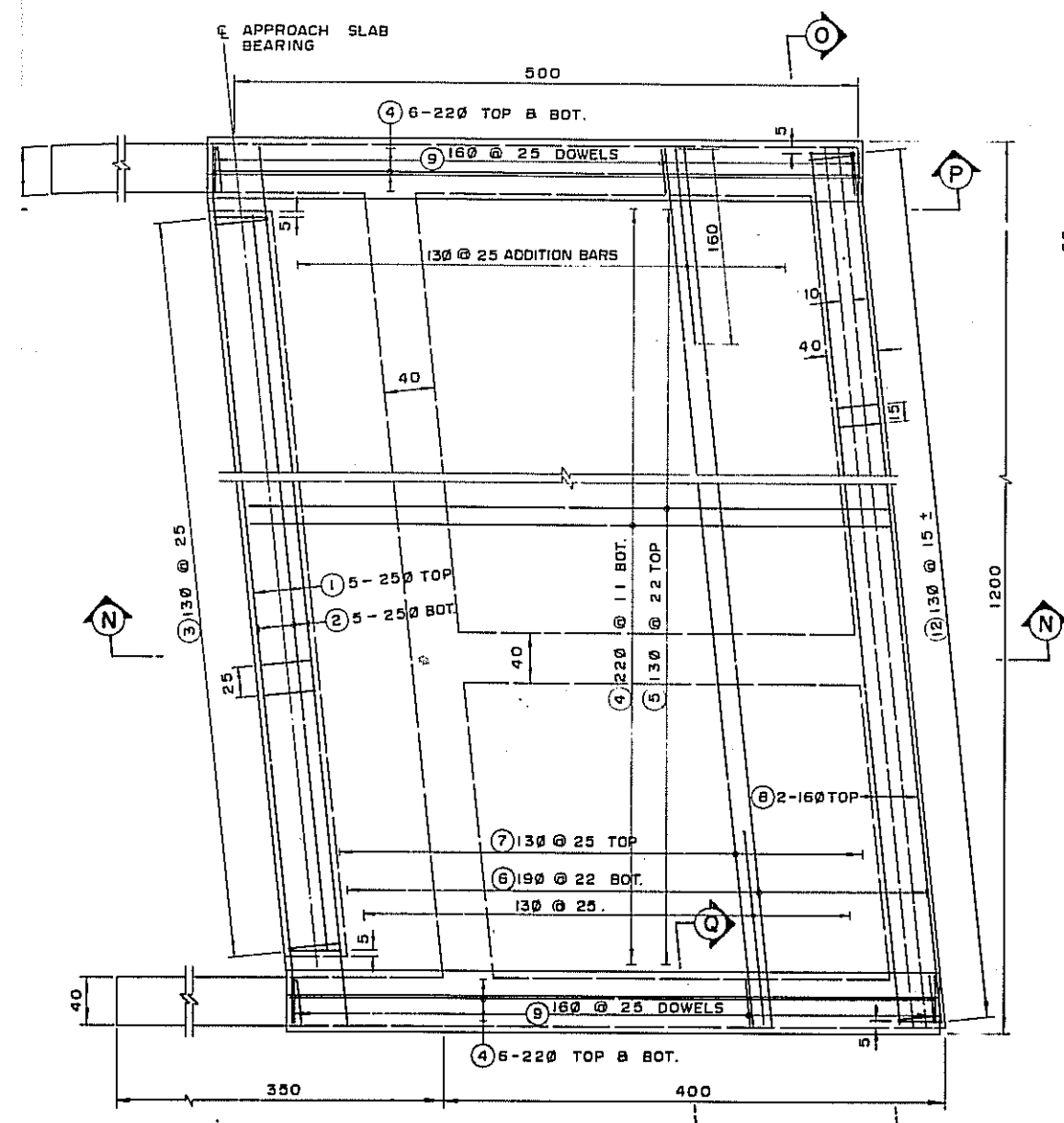

平面圖
PLAN
SCALE 1:30

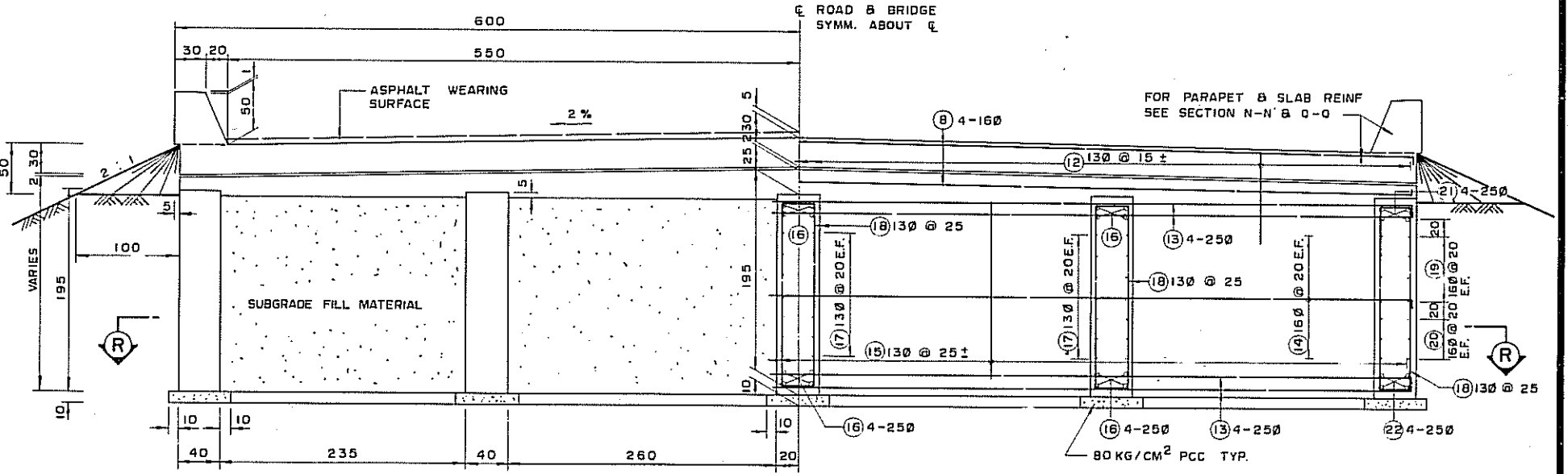

斷面圖 O-O
SECTION O-O
SCALE 1:30

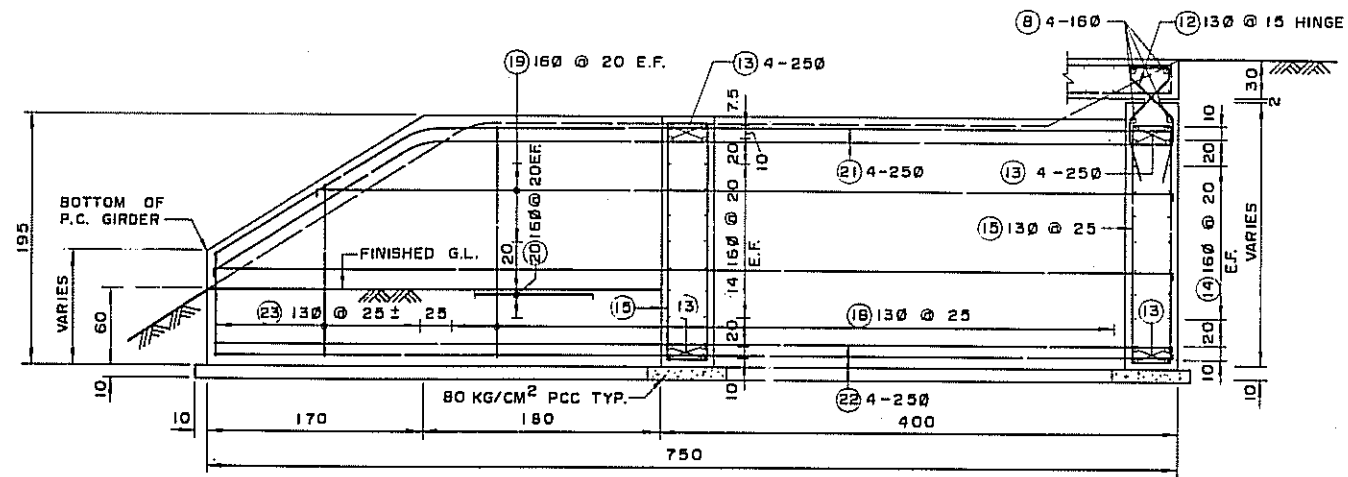

斷面圖 P-P
SECTION P-P
SCALE 1:30

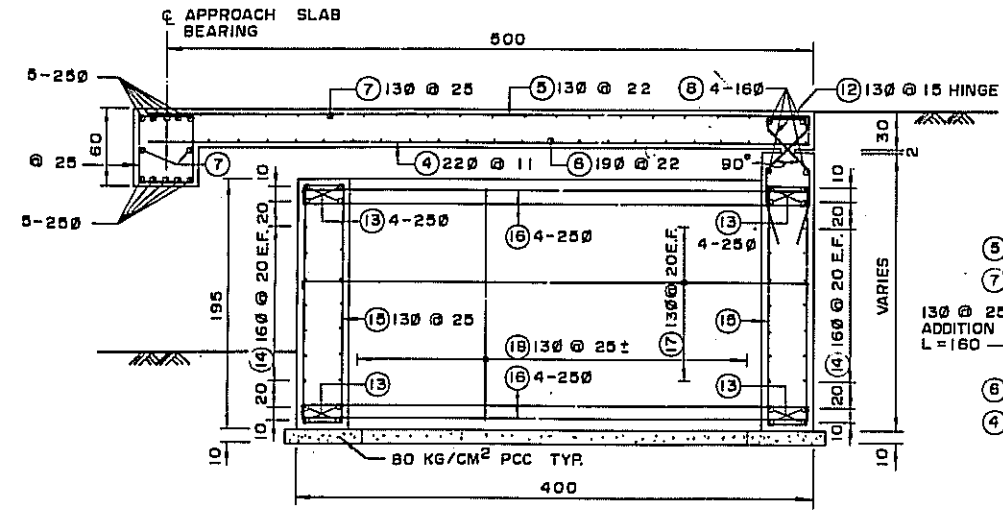

斷面圖 N-N
SECTION N-N
SCALE 1:30

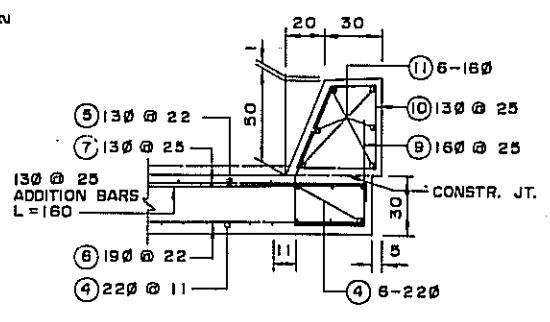

斷面圖 Q-Q
SECTION Q-Q
SCALE 1:20

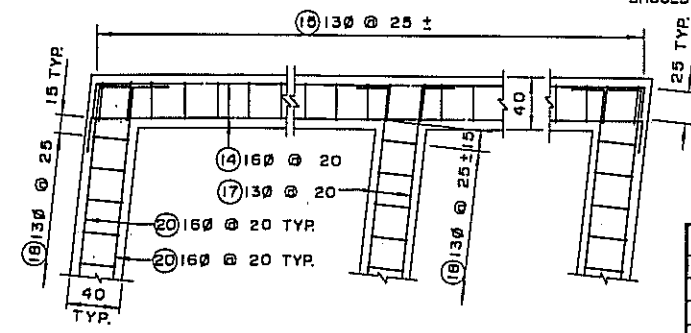

斷面圖 R-R
SECTION R-R
SCALE 1:30

鋼筋表
LIST OF REINFORCING STEELS

SHAPE	NOMINAL DIA. (MM)	REMARK
①	250	
②	250	
③	130	@ 25
④	220	@ 11
⑤	130	@ 22
⑥	190	@ 22
⑦	130	@ 25
⑧	160	
⑨	160	@ 25
⑩	130	@ 25
⑪	160	
⑫	130	@ 15
⑬	250	
⑭	160	@ 20
⑮	130	@ 25
⑯	250	
⑰	130	@ 20
⑱	130	@ 25
⑲	160	VARIES LENGTH
⑳	160	@ 20
㉑	250	
㉒	250	
㉓	130	VARIES SHAPE

說明:
1. 鋼筋明參照圖 SO-36.
2. 箱底填土須確實夯實
NOTES:
1. FOR GENERAL NOTES SEE SHEET SO-36.
2. FILLING MATERIAL UNDER THE BOX SHOULD BE WELL COMPACTED.

PROJECT 60

修正	REVISIONS	項目	ITEM	日期	DATE

交通部台灣區高速公路工程局
TAIWAN AREA FREEWAY CONSTRUCTION BUREAU
中華民國
REPUBLIC OF CHINA
南北高速公路 NORTH-SOUTH FREEWAY
苗栗台中段 MIAOLI-TAICHUNG SECTION
雙車道跨橋(136+177.38) 2-LANE OVERCROSSING
引道版及橋台鋼筋詳圖 APPROACH SLAB & ABUT. REINF. DETAILS
中華顧問工程司 CHINA ENGINEERING CONSULTANTS, INC
日期 DATE AUG. '74 比例 SCALE AS SHOWN 圖號 SHEET SO-17

苗栗
MIAOLI

台中
TAICHUNG

鉸接詳圖
HINGE CONNECTION DETAIL

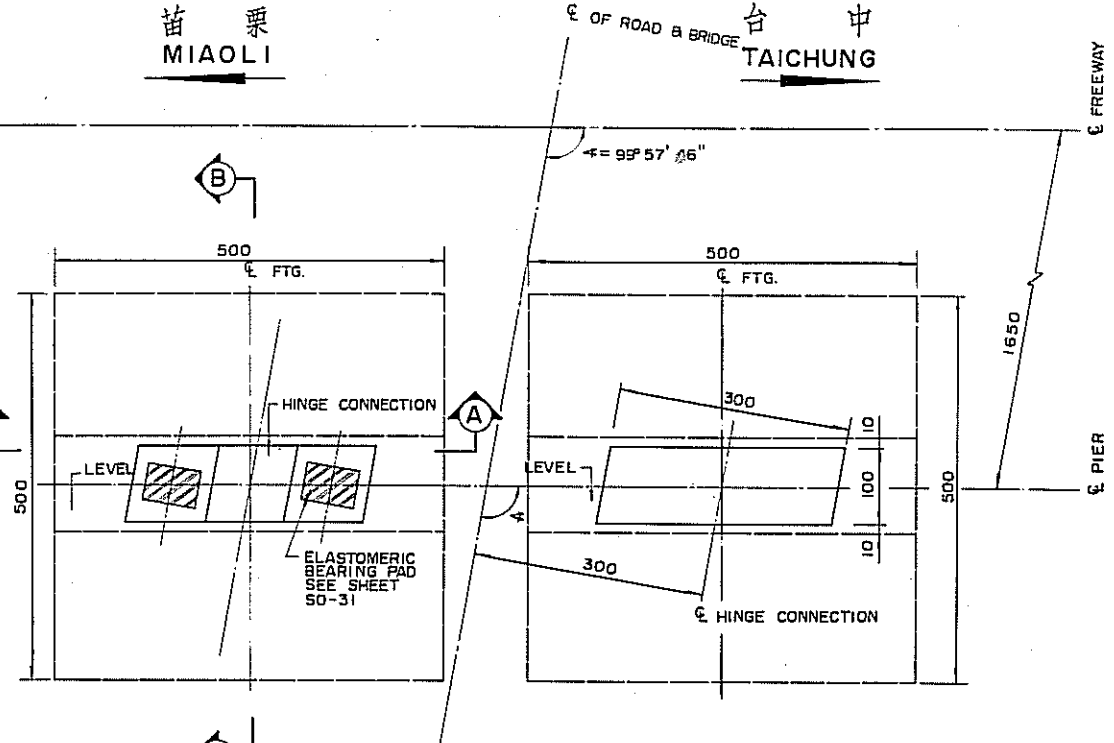

平面圖
PLAN
SCALE 1:50

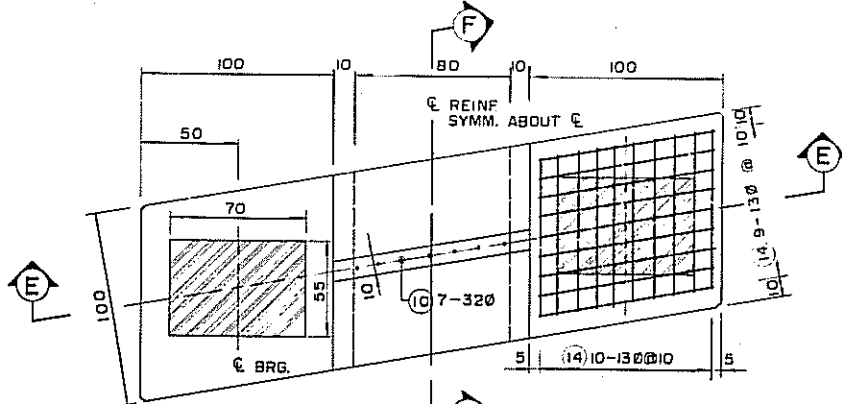

平面圖
PLAN
SCALE 1:20

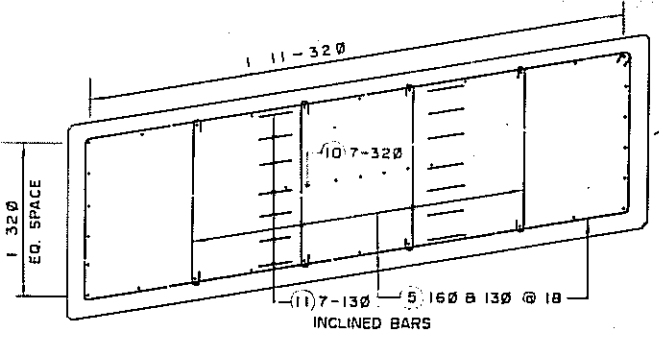

斷面圖 G-G
SECTION G-G
SCALE 1:20

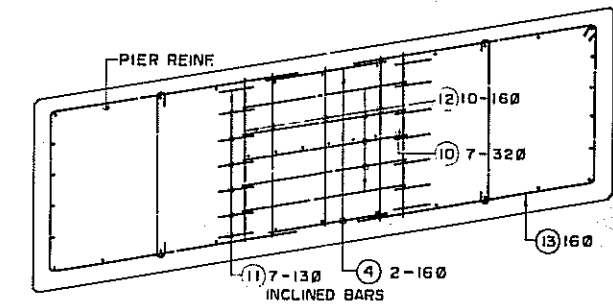

斷面圖 H-H
SECTION H-H
SCALE 1:20

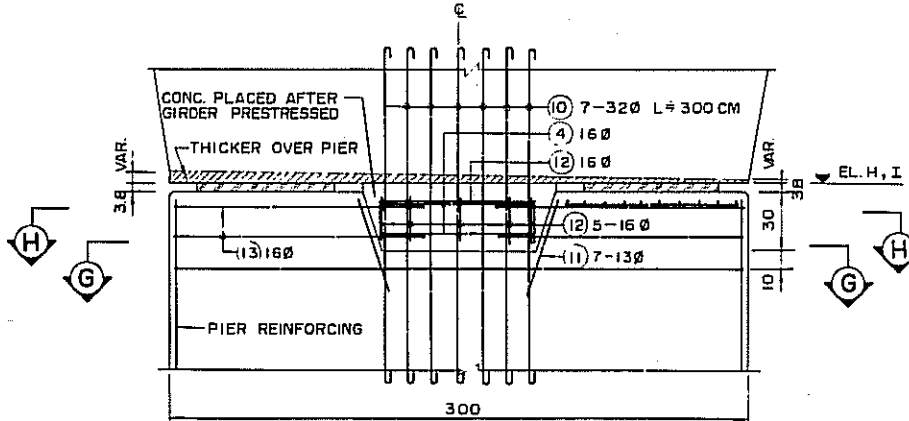

斷面圖 E-E
SECTION E-E
SCALE 1:20

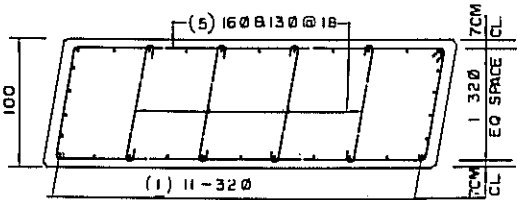

斷面圖 C-C
SECTION C-C
SCALE 1:30

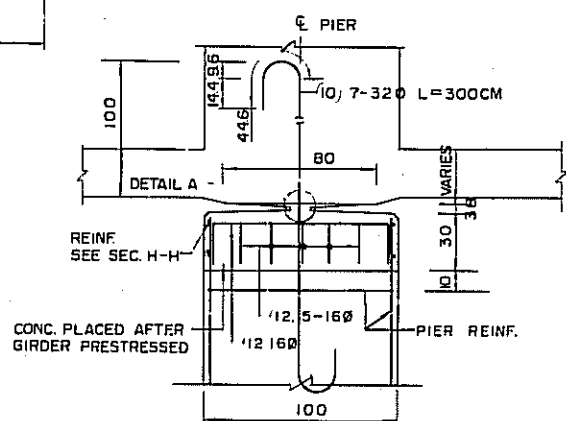

斷面圖 F-F
SECTION F-F
SCALE 1:20

說明:
總說明參照圖 SO-36.
NOTE:
FOR GENERAL NOTES SEE SHEET SO-36.

鋼筋表
LIST OF REINFORCING STEELS

SHAPE	NOMINAL DIA. (MM)	REMARK
①	320	
②	320	
③		
④	160	
⑤	160 & 130	130 /
⑥	250	@ 20
⑦	190	@ 20
⑧	220	@ 20
⑨	160	
⑩	320	
⑪	130	
⑫	160	
⑬	160	
⑭	130	@ 10

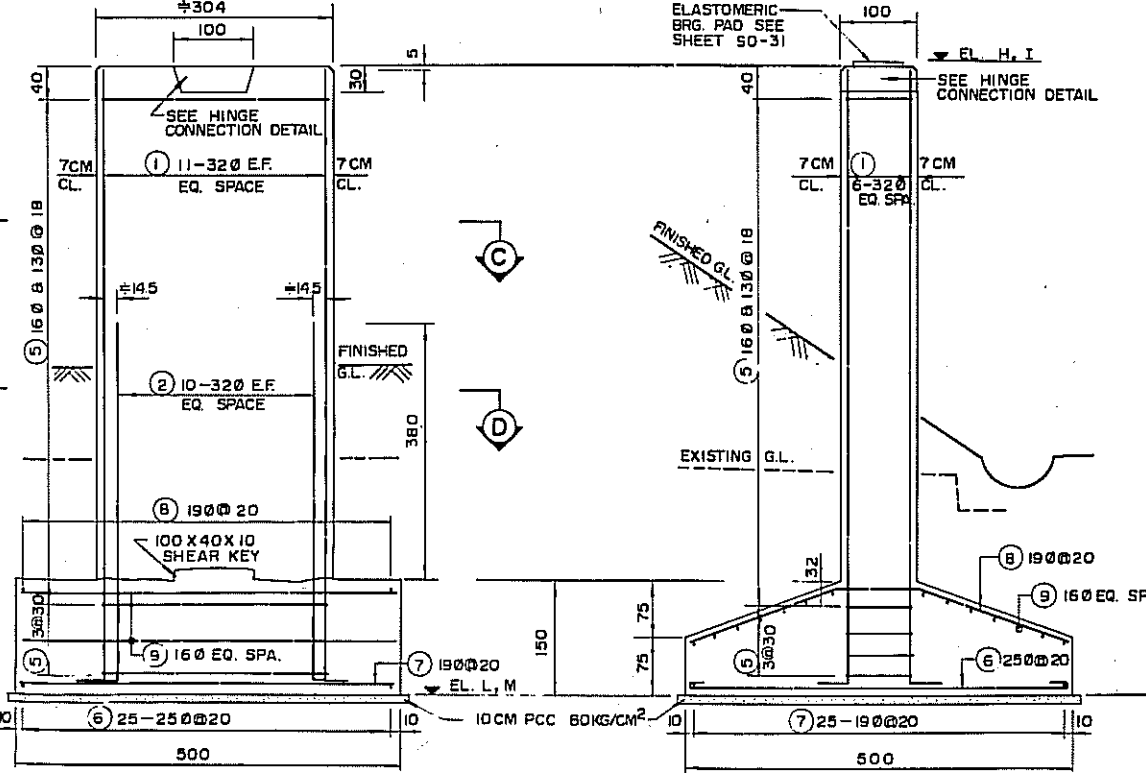

斷面圖 A-A
SECTION A-A
SCALE 1:50

MAX. DESIGN FOUNDATION PRESSURE = 28 T/M²

斷面圖 B-B
SECTION B-B
SCALE 1:50

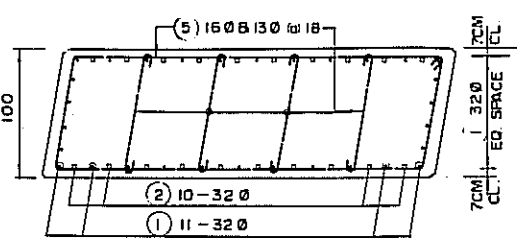

斷面圖 D-D
SECTION D-D
SCALE 1:30

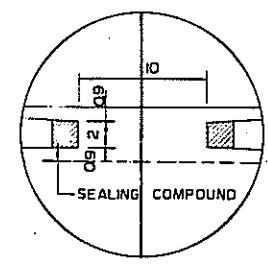

詳圖 A
DETAIL A
SCALE 1:3

PROJECT 60

修正 REVISIONS	項目 ITEM	日期 DATE	說明 REMARKS

交通部台灣區高速公路工程局
TAIWAN AREA FREEWAY CONSTRUCTION BUREAU
中華民國
REPUBLIC OF CHINA
南北高速公路 NORTH-SOUTH FREEWAY
苗栗台中段 MIAOLI-TAICHUNG SECTION
雙車道橋樑(136+177.38) 2-LANE OVERCROSSING
橋墩鋼筋詳圖 PIER REINF. DETAILS
中華顧問工程司 CHINA ENGINEERING CONSULTANTS, INC.
日期 DATE AUG. '74 比例 SCALE AS SHOWN 圖號 SHEET SO-18

19
37
0
6

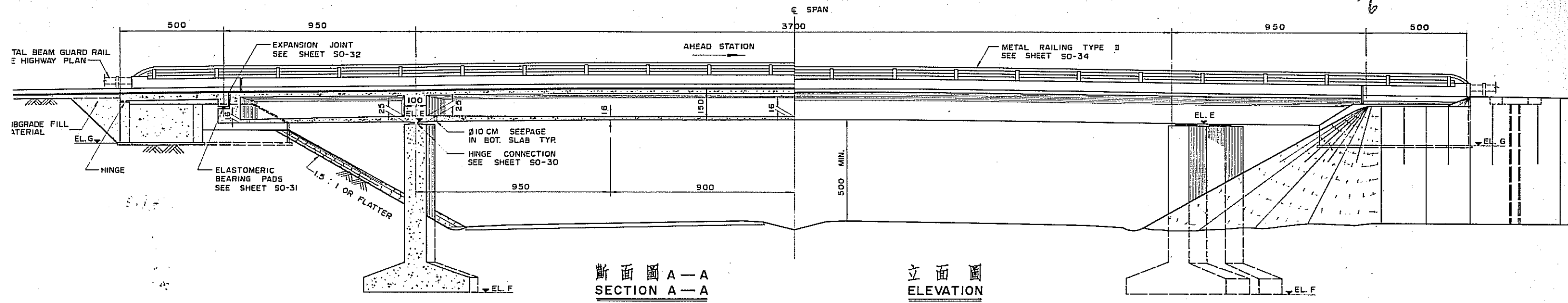

斷面圖 A-A
SECTION A-A

立面圖
ELEVATION

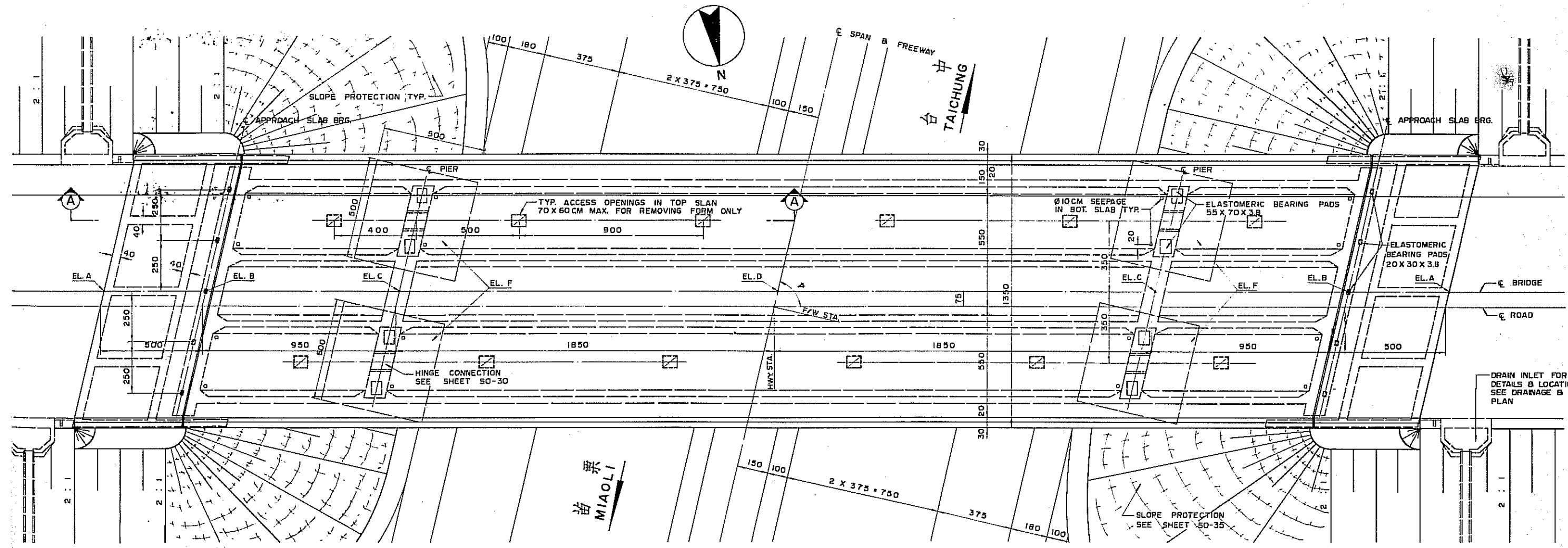

平面圖
PLAN

說明:
總說明參照圖 50-36.

NOTE:
FOR GENERAL NOTES SEE SHEET 50-36.

PR. NO.	STATION FREEWAY	STATION HIGHWAY	CROSS-ANGLE A	ELEVATIONS (ON TOP OF W.S.)				ELEVATIONS			REMARKS
				A	B	C	D	**E	F	G	
60	135 + 864.91	0 + 315.68	76° 24' 17"	208.152	208.213	208.302	208.370	206.752	198.41	195.58	

修正	REVISIONS	項目	ITEM	日期	DATE

交通部台灣區高速公路工程局
TAIWAN AREA FREEWAY CONSTRUCTION BUREAU
中華民國
REPUBLIC OF CHINA
南北高速公路
NORTH-SOUTH FREEWAY
苗栗台中段
MIAOLI-TAICHUNG SECTION
雙車道橋樑(135+864.91) 2-LANE OVERCROSSING
總平面圖
GENERAL PLAN
中華顧問工程司
CHINA ENGINEERING CONSULTANTS, INC.
日期 DATE AUG. '74 比例 SCALE 1:100 圖號 SHEET 50-25

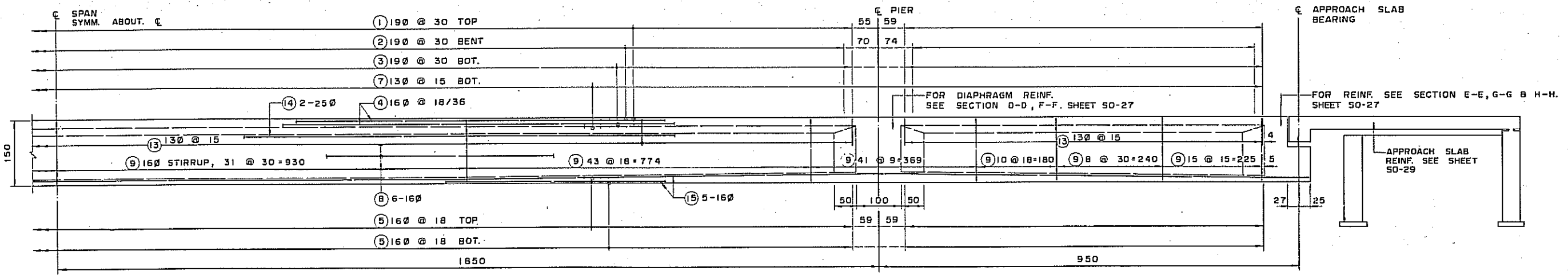

斷面圖 B-B
SECTION B-B
SCALE 1:50

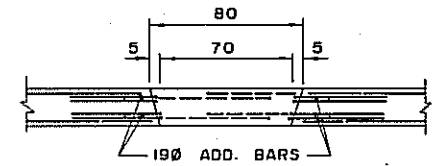

斷面圖 J-J
SECTION J-J

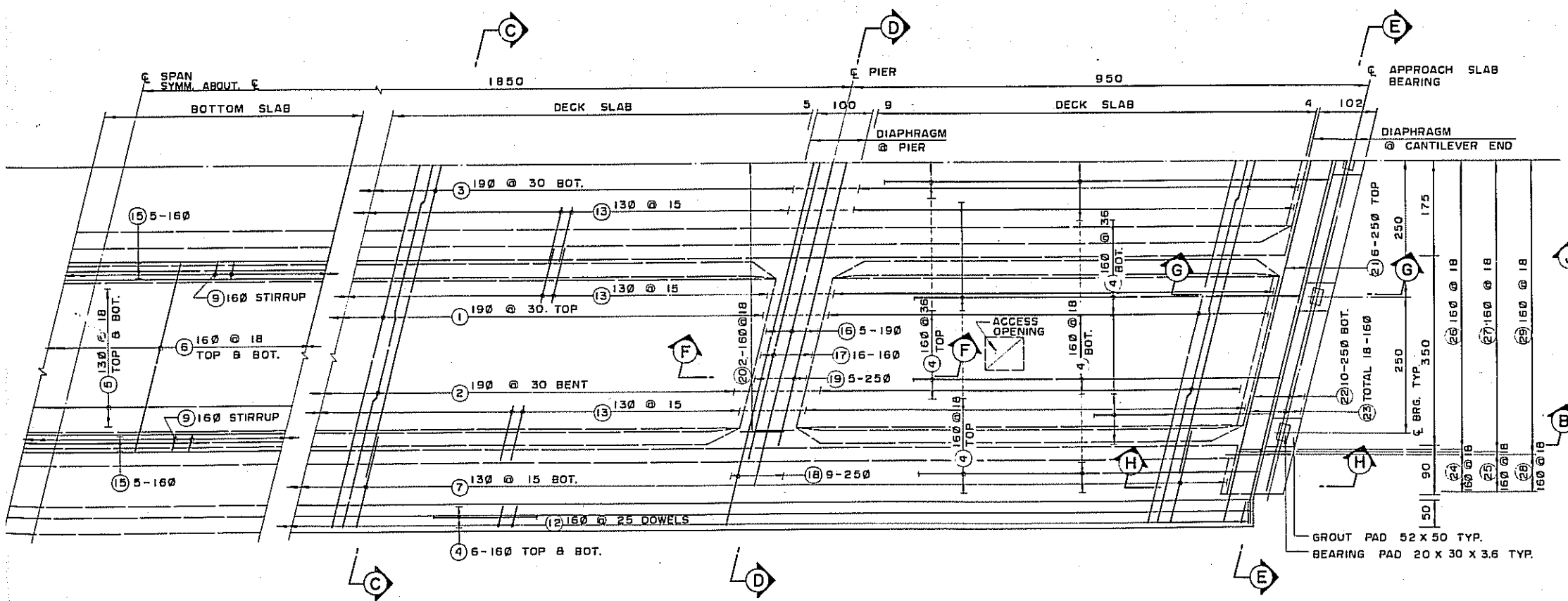

平面圖
PLAN
SCALE 1:50

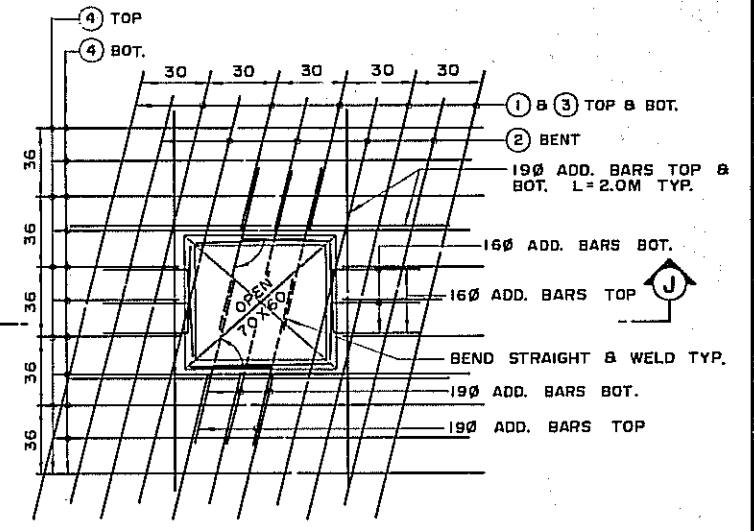

平面圖
PLAN
臨時孔道標準配筋圖
TYP. REINF. AT ACCESS OPENING
SCALE 1:20

說明:

總說明參照圖 SO-36。

NOTE:

FOR GENERAL NOTES SEE SHEET SO-36.

修正 REVISIONS		日期 DATE	交通部台灣區高速公路工程局 TAIWAN AREA FREEWAY CONSTRUCTION BUREAU 中華民國 台北高速公路 NORTH-SOUTH FREEWAY 苗栗台中段 MIAOLI-TAICHUNG SECTION 雙連橋址(135+864.91) 2-LANE OVERCROSSING 上部結構鋼筋詳圖(I) SUPERSTR. REINF. DETAIL(I) 中華顧問工程司 CHINA ENGINEERING CONSULTANTS INC. 日期 DATE AUG. '74 比例 SCALE AS SHOWN 圖號 SHEET SO-26
項目 ITEM			

PROJECT 60

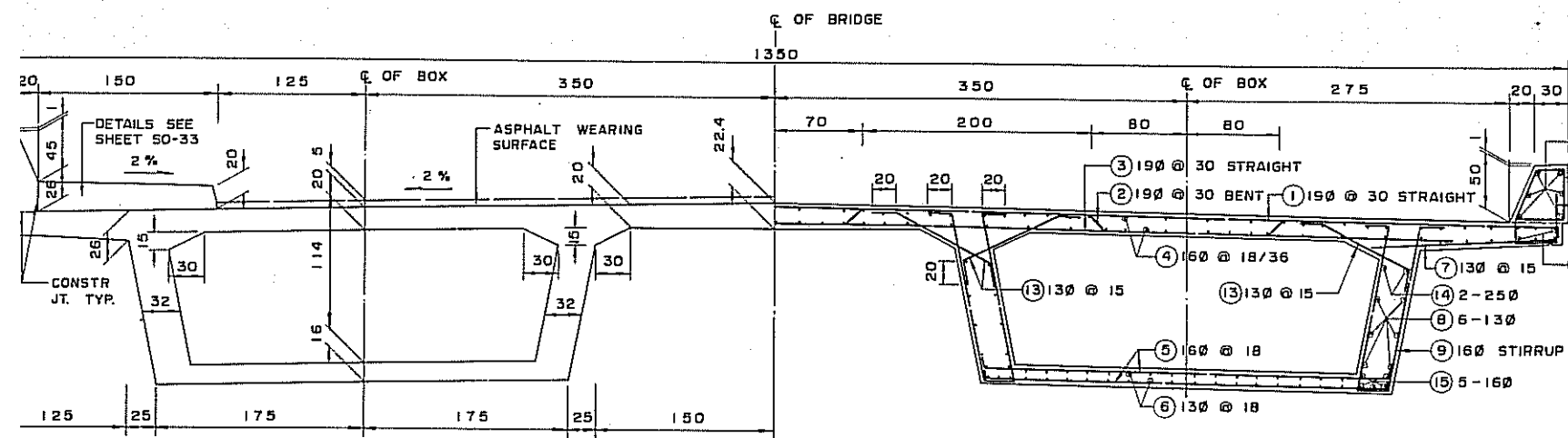

斷面圖 C-C
SECTION C-C
SCALE 1:30

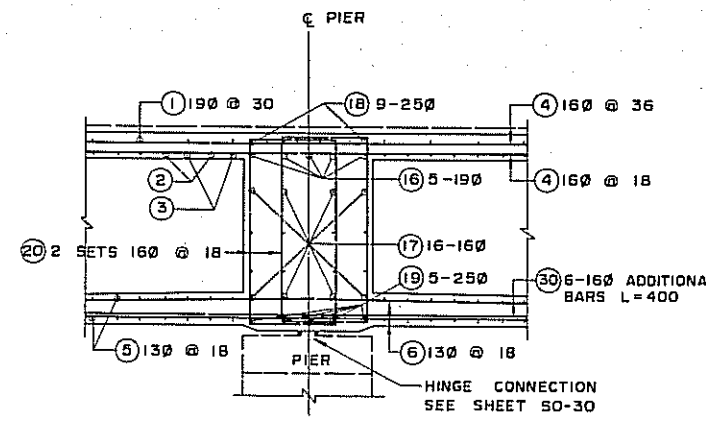

斷面圖 F-F
SECTION F-F
SCALE 1:30

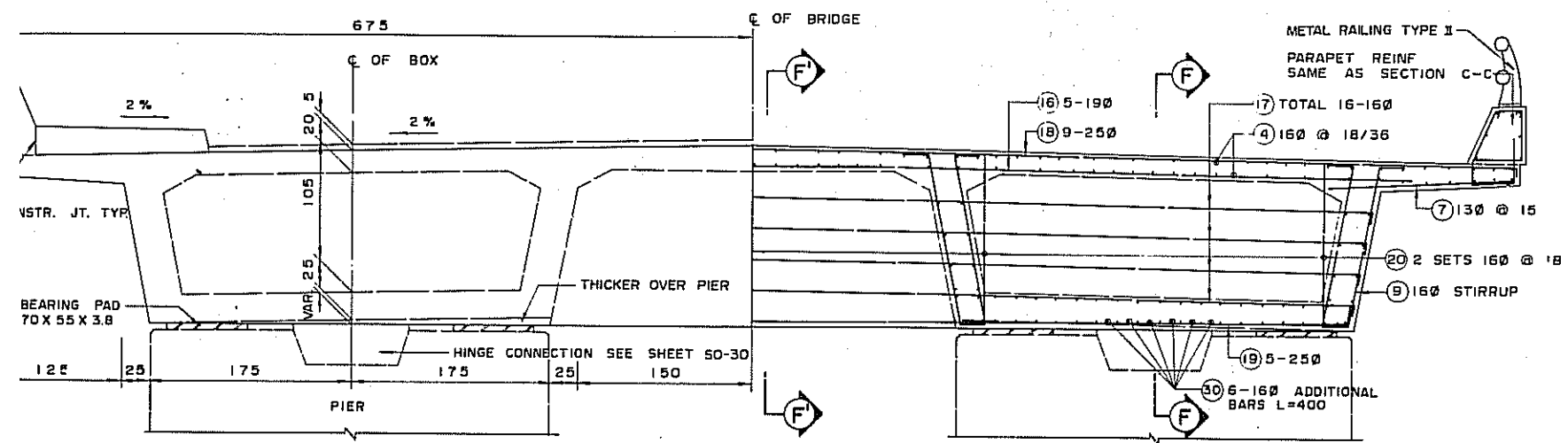

斷面圖 D-D
SECTION D-D
SCALE 1:30

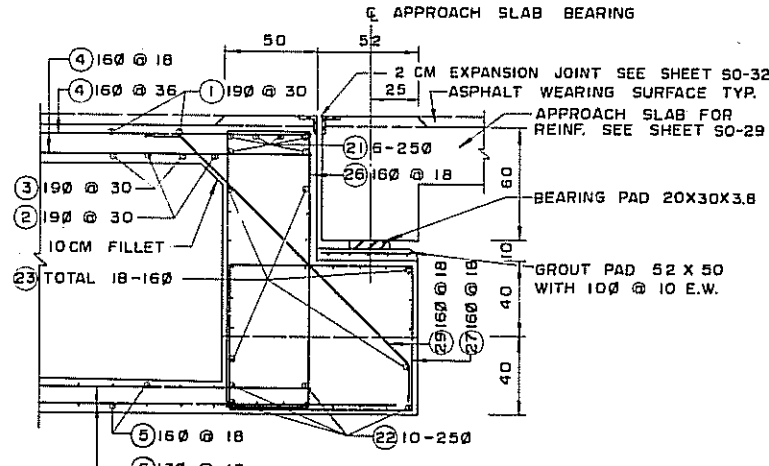

斷面圖 G-G
SECTION G-G
SCALE 1:20

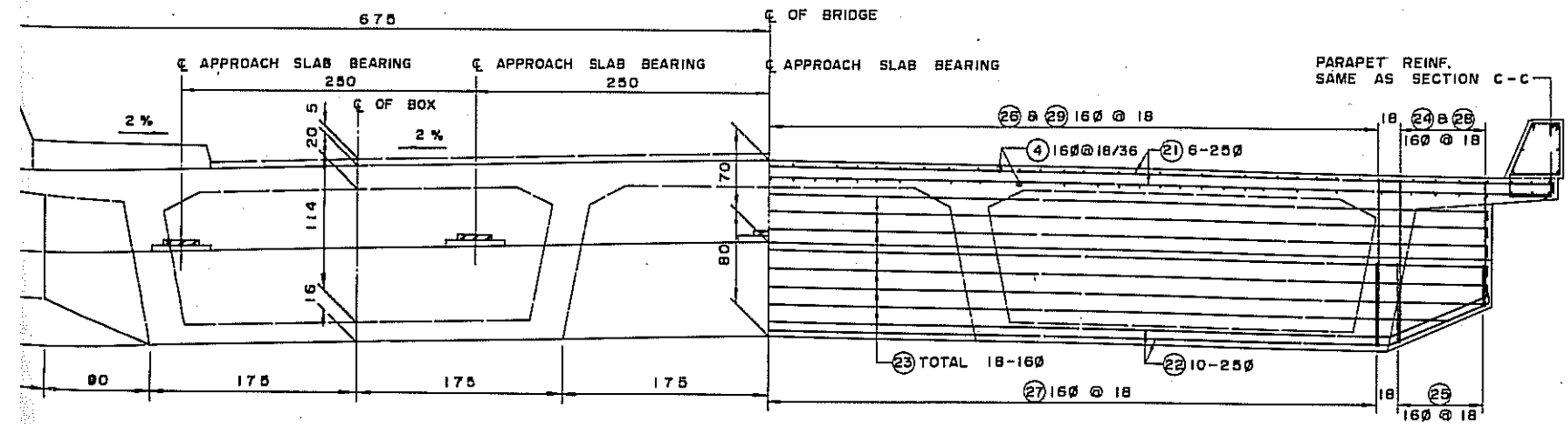

斷面圖 E-E
SECTION E-E
SCALE 1:30

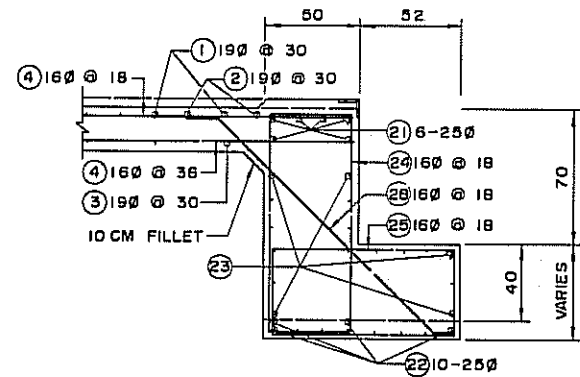

斷面圖 H-H
SECTION H-H
SCALE 1:20

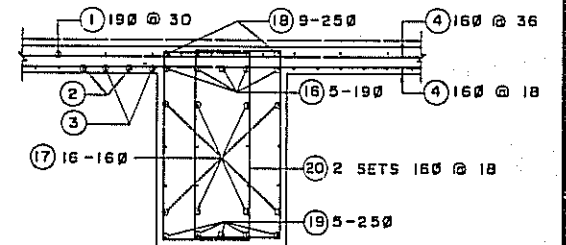

斷面圖 F'-F'
SECTION F'-F'
SCALE 1:30

鋼筋表
LIST OF REINFORCING STEELS

SHAPE	NOMINAL DIA. (MM)	REMARK
①	19Ø	@ 30
②	19Ø	@ 30
③	19Ø	@ 30
④	16Ø	@ 18/36
⑤	16Ø	@ 18
⑥	13Ø	@ 18
⑦	13Ø	@ 15
⑧	13Ø	@ 15
⑨	16Ø	
⑩	13Ø	@ 25
⑪	16Ø	
⑫	16Ø	@ 25
⑬	13Ø	@ 15
⑭	25Ø	
⑮	16Ø	
⑯	19Ø	
⑰	16Ø	
⑱	25Ø	
⑲	25Ø	
⑳	16Ø	@ 18
㉑	25Ø	
㉒	25Ø	
㉓	16Ø	
㉔	16Ø	@ 18
㉕	16Ø	@ 18
㉖	16Ø	@ 18
㉗	16Ø	@ 18
㉘	16Ø	@ 18
㉙	16Ø	@ 18
㉚	16Ø	

修正 REVISIONS	項目 ITEM	日期 DATE

交通部台灣區高速公路工程局
TAIWAN AREA FREEWAY CONSTRUCTION BUREAU
中華民國
REPUBLIC OF CHINA
南北高速公路 NORTH-SOUTH FREEWAY
苗栗台中段 MIAOLI-TAICHUNG SECTION
雙連跨橋(135+864.91) 2-LANE OVERCROSSING
上部結構鋼筋詳圖(II) SUPERSTR. REINF. DETAIL(II)
中華顧問工程司 CHINA ENGINEERING CONSULTANTS, INC.
日期 DATE AUG. '74 比例 SCALE AS SHOWN 圖號 SHEET SD-27

PROJECT 60

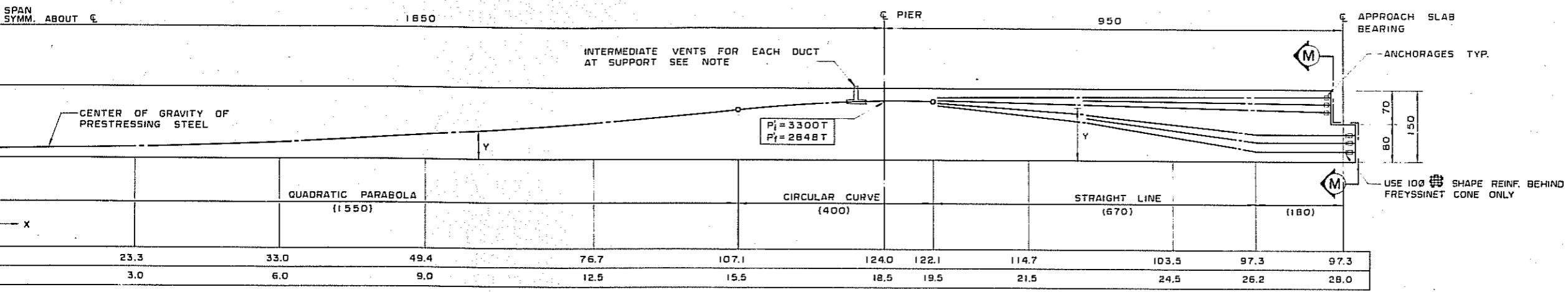

斷面圖 K-K
SECTION K-K
SCALE 1:50

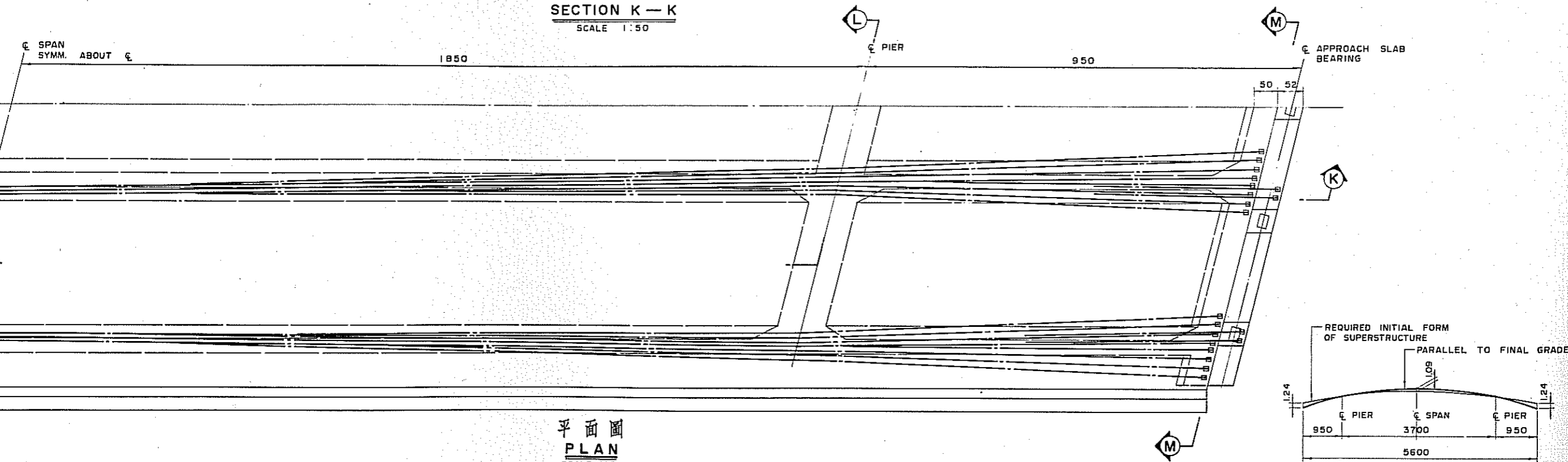

平面圖
PLAN
SCALE 1:50

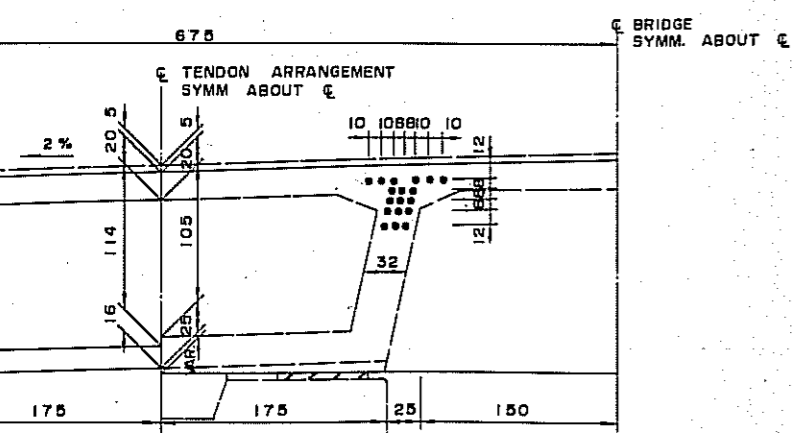

斷面圖 L-L

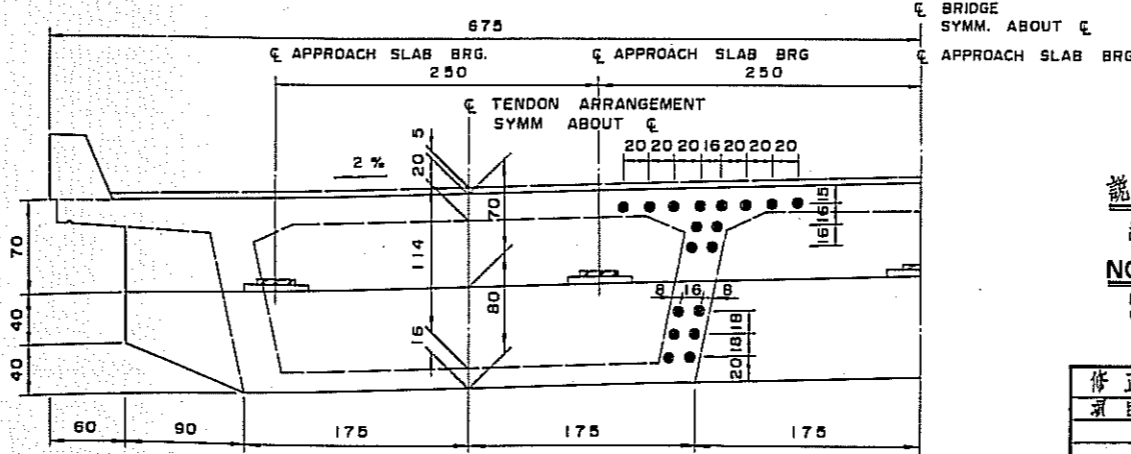

斷面圖 M-M

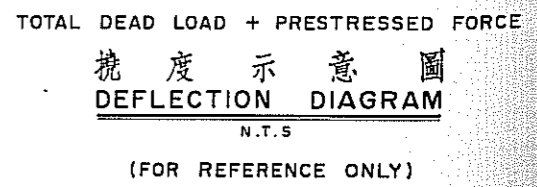

說明:
撓度說明及預力混凝土箱樑說明參照圖 50-36.

NOTE:
FOR GENERAL NOTES & NOTES FOR P.C. BOX GIRDER SEE SHEET 50-36.

修正	REVISIONS	項目	ITEM	日期	DATE

PROJECT 60

交通部台灣區高速公路工程局
TAIWAN AREA FREEWAY CONSTRUCTION BUREAU
中華民國
REPUBLIC OF CHINA
南北高速公路 NORTH-SOUTH FREEWAY
苗栗台中段 MIAOLI-TAICHUNG SECTION
苗栗台中段 OVERCROSSING

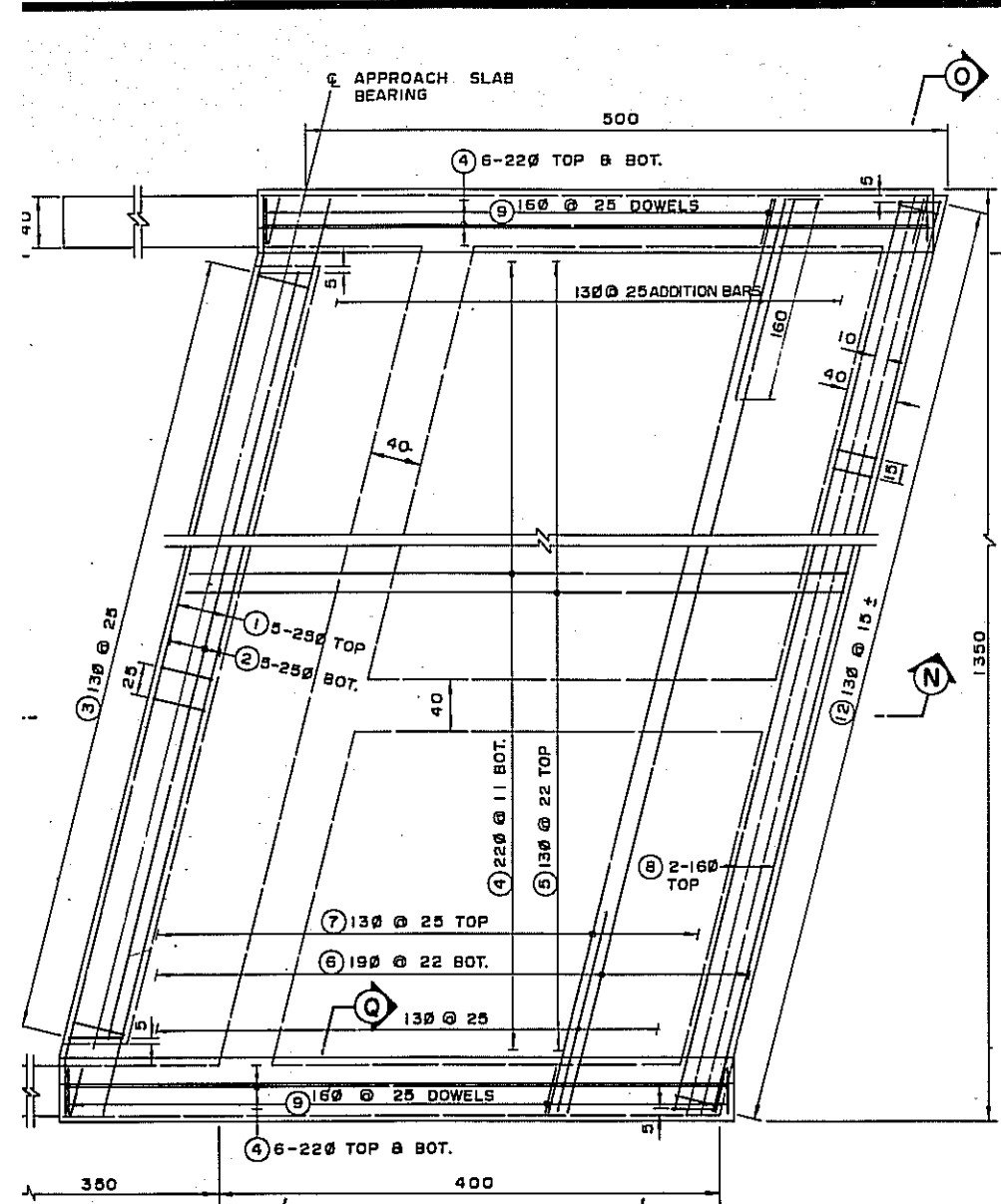

斷面圖
PLAN
SCALE 1:30

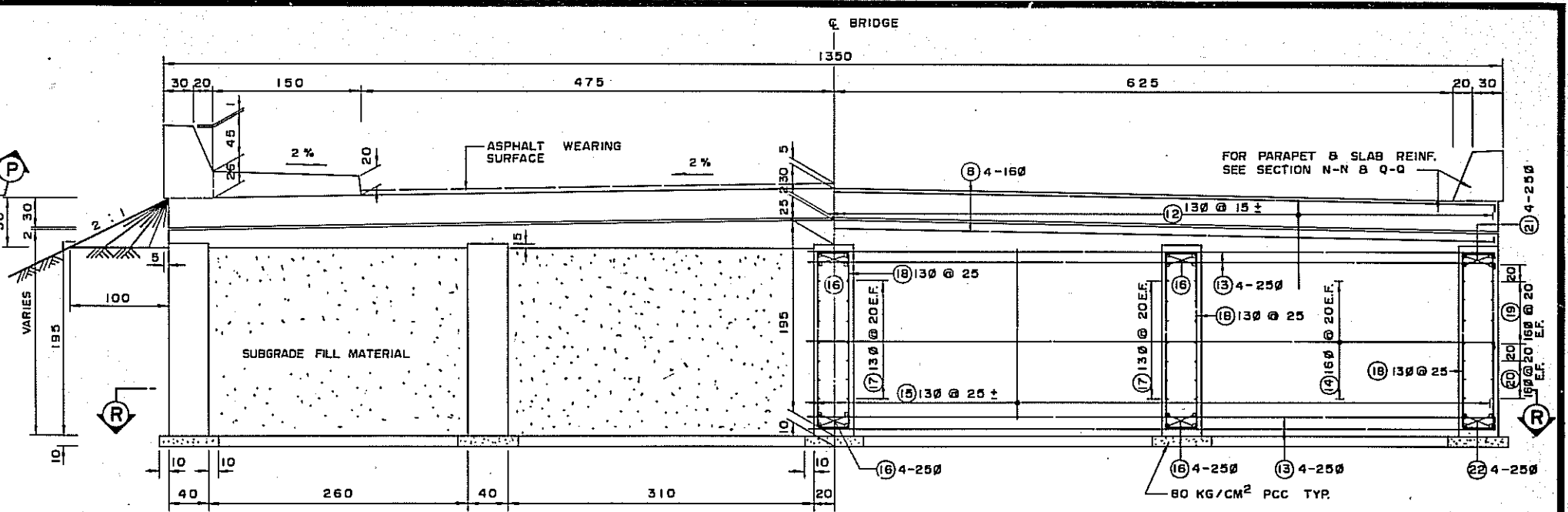

斷面圖 O-O
SECTION O-O
SCALE 1:30

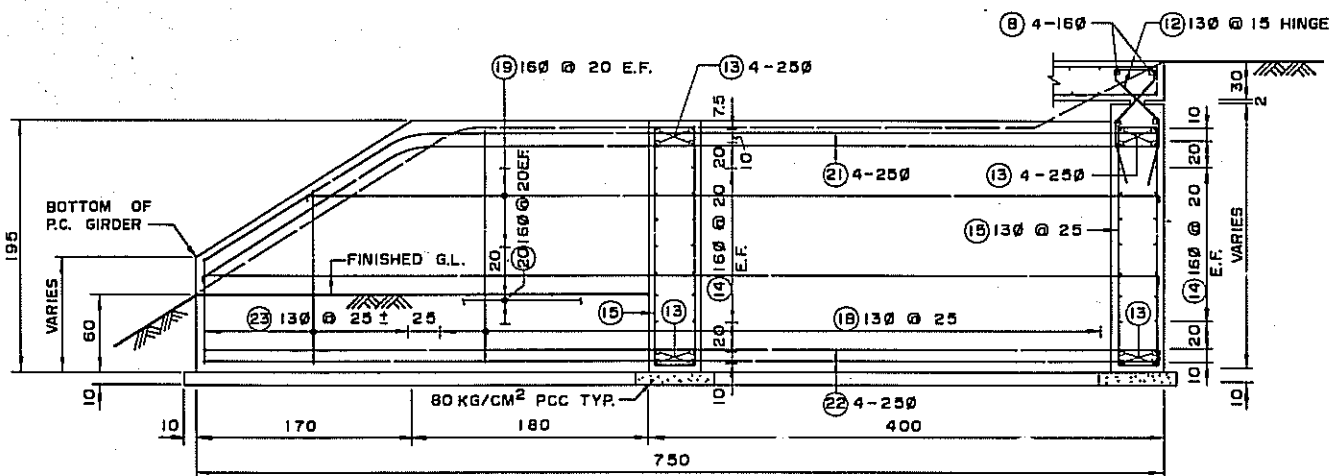

斷面圖 P-P
SECTION P-P
SCALE 1:30

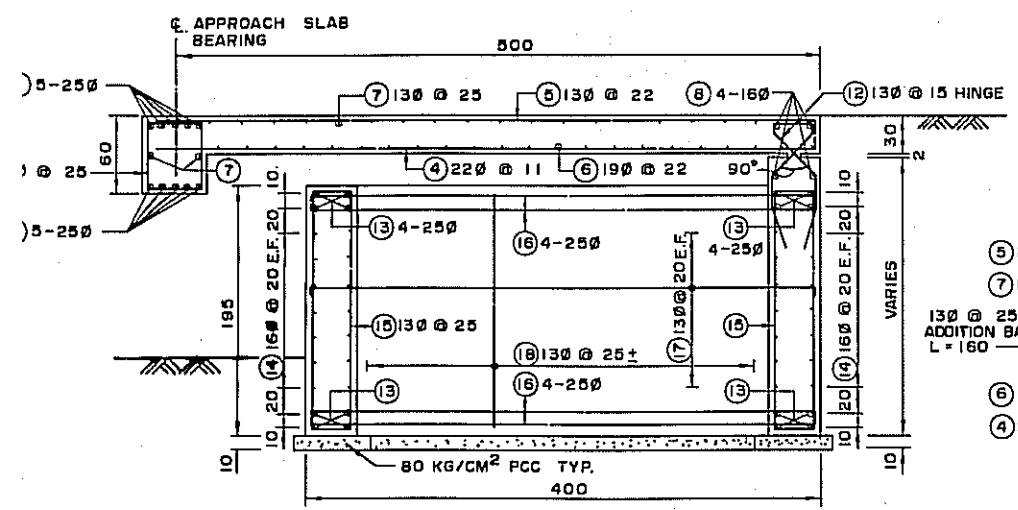

斷面圖 N-N
SECTION N-N
SCALE 1:30

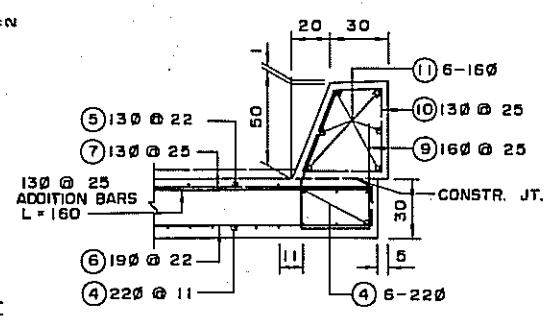

斷面圖 Q-Q
SECTION Q-Q
SCALE 1:20

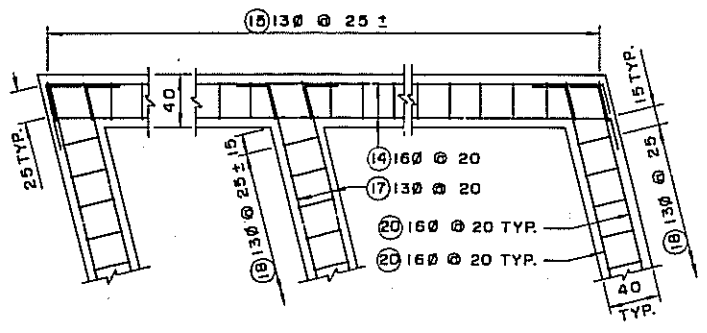

斷面圖 R-R
SECTION R-R
SCALE 1:30

鋼筋表
LIST OF REINFORCING STEELS

SHAPE	NOMINAL DIA. (MM)	REMARK
①	25ø	
②	25ø	
③	13ø	@ 25
④	22ø	@ 11
⑤	13ø	@ 22
⑥	19ø	@ 22
⑦	13ø	@ 25
⑧	16ø	
⑨	16ø	@ 25
⑩	13ø	@ 25
⑪	16ø	
⑫	13ø	@ 15
⑬	25ø	
⑭	16ø	@ 20
⑮	13ø	@ 25
⑯	25ø	
⑰	13ø	@ 20
⑱	13ø	@ 25
⑲	16ø	VARIES LENGTH
⑳	16ø	@ 20
㉑	25ø	
㉒	25ø	
㉓	13ø	VARIES SHAPE

說明:

1. 總說明參照圖 SO-36.
2. 箱底填土需確實夯實.

NOTE:

1. FOR GENERAL NOTES SEE SHEET SO-36.
2. FILLING MATERIAL UNDER THE BOX SHOULD BE WELL COMPACTED.

修正 REVISIONS	項目 ITEM	日期 DATE	交通部台灣區高速公路工程局 TAIWAN AREA FREEWAY CONSTRUCTION BUREAU 中華民國 REPUBLIC OF CHINA 南北高速公路 MIAOLI-TAICHUNG SECTION 苗栗台中段 雙連路跨線橋 (K35+864.91) 引道版及橋台鋼筋詳圖 中華顧問工程司 CHINA ENGINEERING CONSULTANTS, INC.
			2-LANE OVERCROSSING APPROACH SLAB & ABUT. REINF. DETAILS
			日期 DATE AUG. '74 比例 SCALE AS SHOWN 圖號 SHEET SO-29

苗栗
MIAOLI

台中
TAICHUNG

鉸接詳圖
HINGE CONNECTION DETAIL

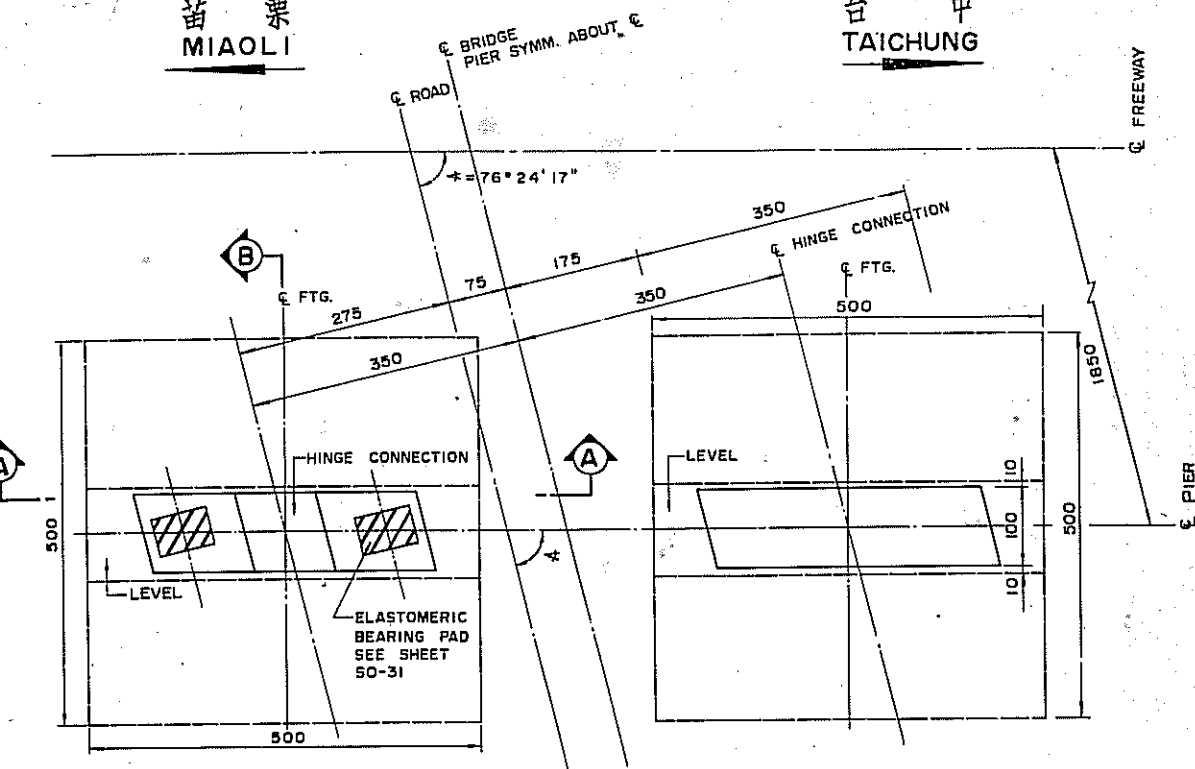

平面圖
PLAN
SCALE 1:100

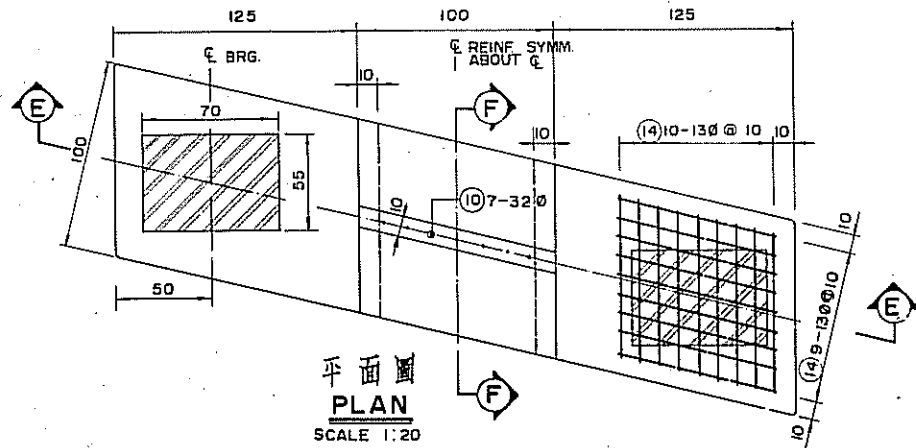

平面圖
PLAN
SCALE 1:20

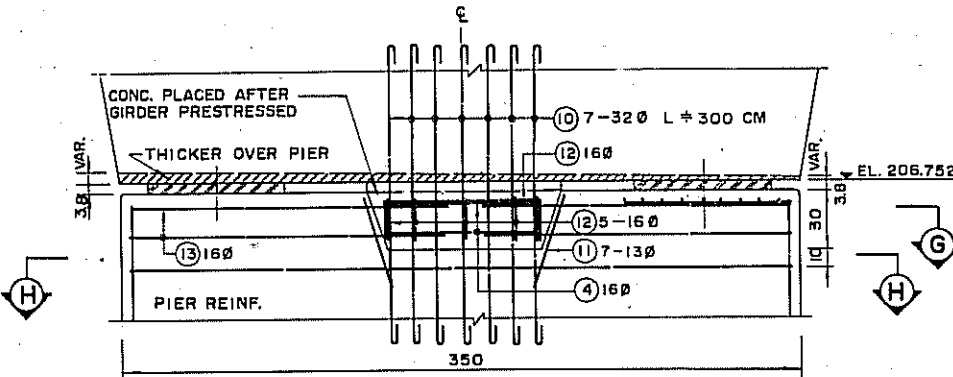

斷面圖 E-E
SECTION E-E
SCALE 1:20

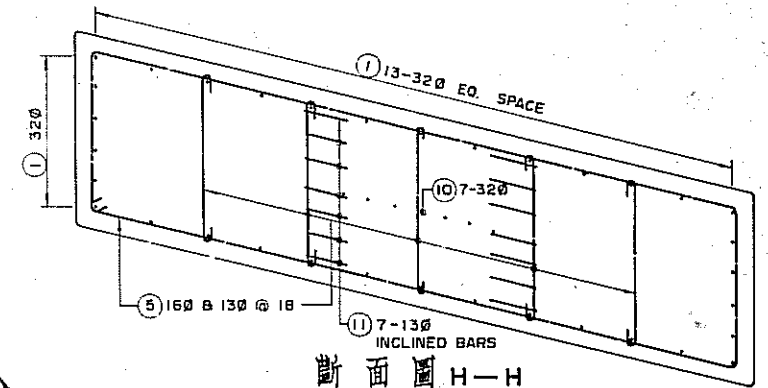

斷面圖 H-H
SECTION H-H
SCALE 1:20

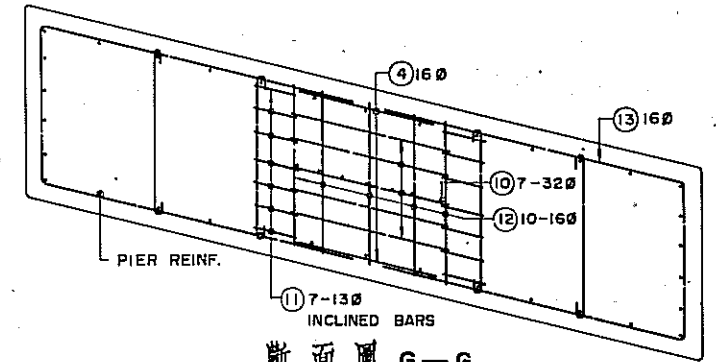

斷面圖 G-G
SECTION G-G
SCALE 1:20

鋼筋表
LIST OF REINFORCING STEELS

SHAPE	NOMINAL DIA. (MM)	REMARK
(1)	32Ø	
(2)	32Ø	
(3)		
(4)	16Ø	
(5)	16Ø B 13Ø	13Ø ∠
(6)	25Ø	@ 20
(7)	16Ø	@ 25
(8)	19Ø	@ 20
(9)	16Ø	
(10)	32Ø	
(11)	13Ø	
(12)	16Ø	
(13)	16Ø	
(14)	13Ø	@ 10

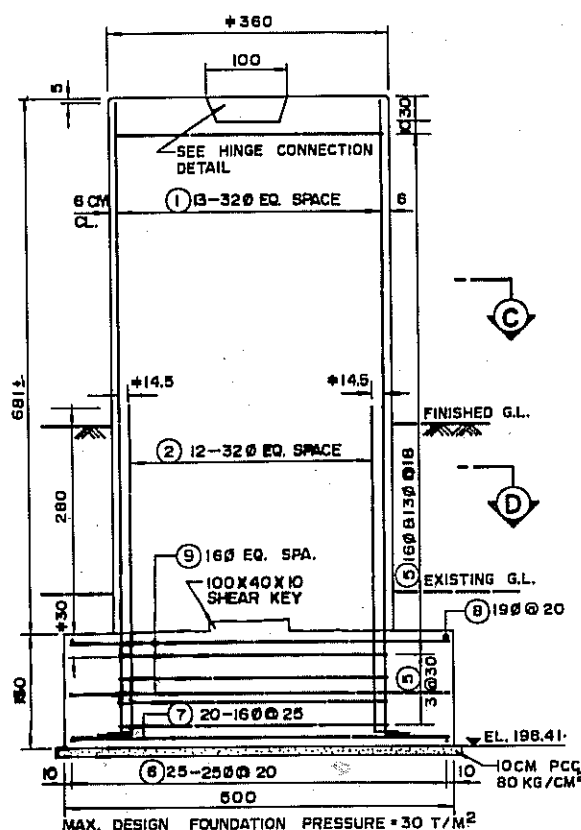

斷面圖 A-A
SECTION A-A
SCALE 1:50

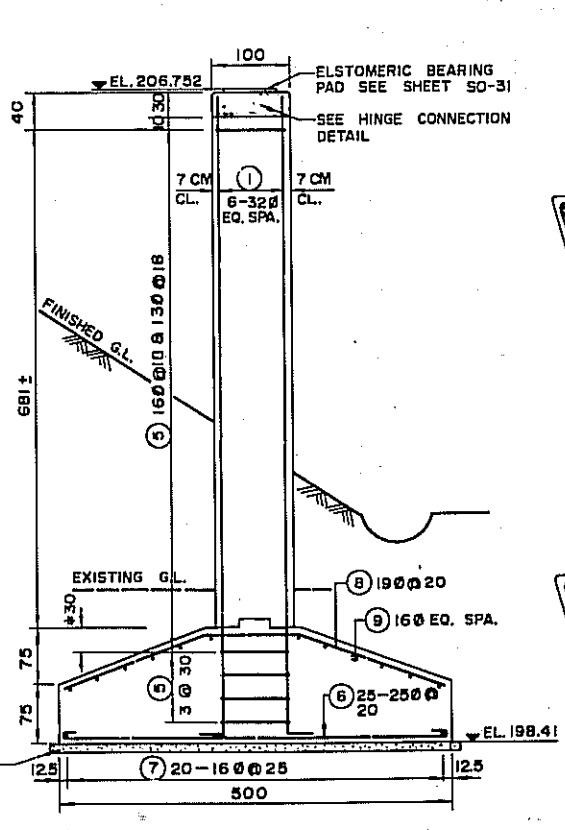

斷面圖 B-B
SECTION B-B
SCALE 1:50

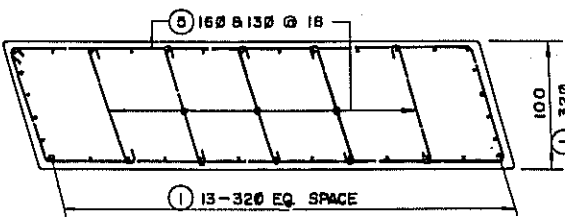

斷面圖 C-C
SECTION C-C
SCALE 1:30

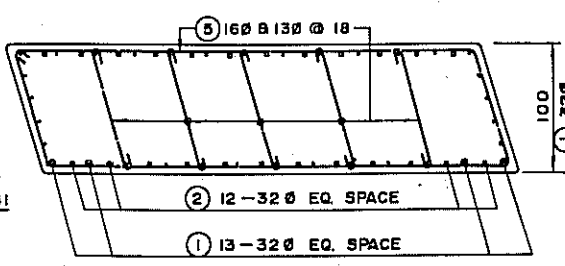

斷面圖 D-D
SECTION D-D
SCALE 1:30

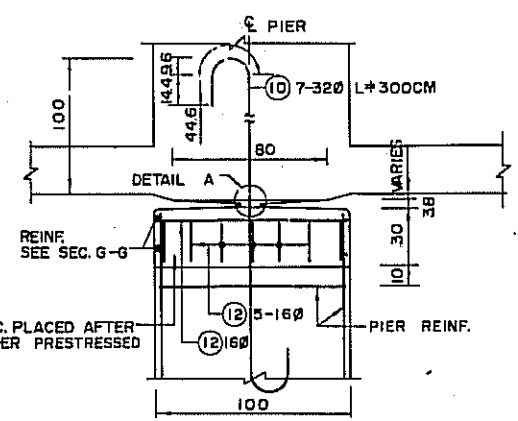

斷面圖 F-F
SECTION F-F
SCALE 1:20

說明:
應說明參照圖 SO-36.
NOTE:
FOR GENERAL NOTES SEE SHEET SO-36.

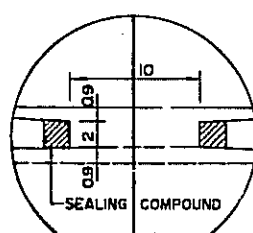

詳圖 A
DETAIL A
SCALE 1:3

PROJECT 60

修正 REVISIONS	項目 ITEM	日期 DATE

交通部台灣區高速公路工程局
TAIWAN AREA FREEWAY CONSTRUCTION BUREAU
中華民國
REPUBLIC OF CHINA
南北高速公路 NORTH-SOUTH FREEWAY
苗栗台中段 MIAOLI-TAICHUNG SECTION
雙連跨橋 (135+864.91) 2-LANE OVERCROSSING
橋墩鋼筋詳圖 PIER REINF. DETAILS
中華顧問工程司 CHINA ENGINEERING CONSULTANTS, INC.
日期 DATE AUG. '74 比例 SCALE AS SHOWN 圖號 SHEET SO-30

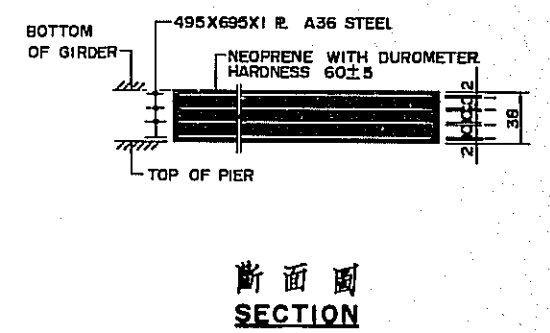
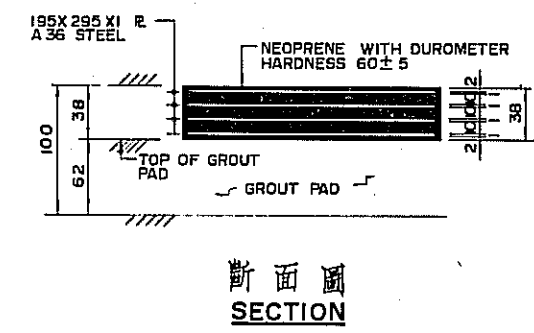
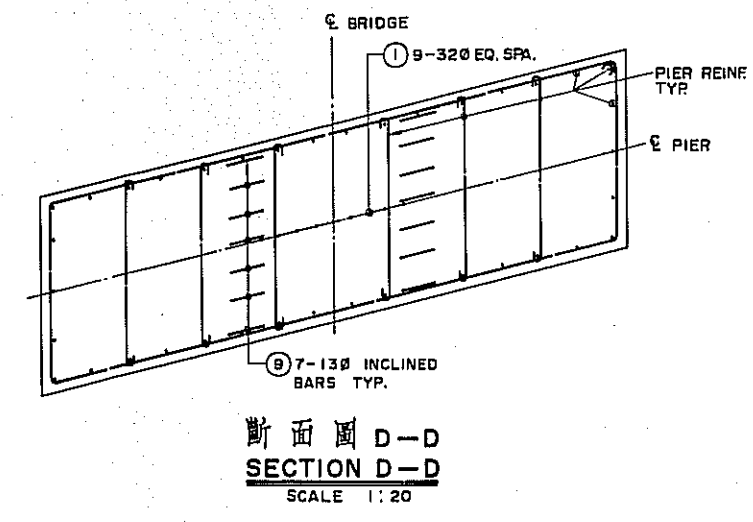
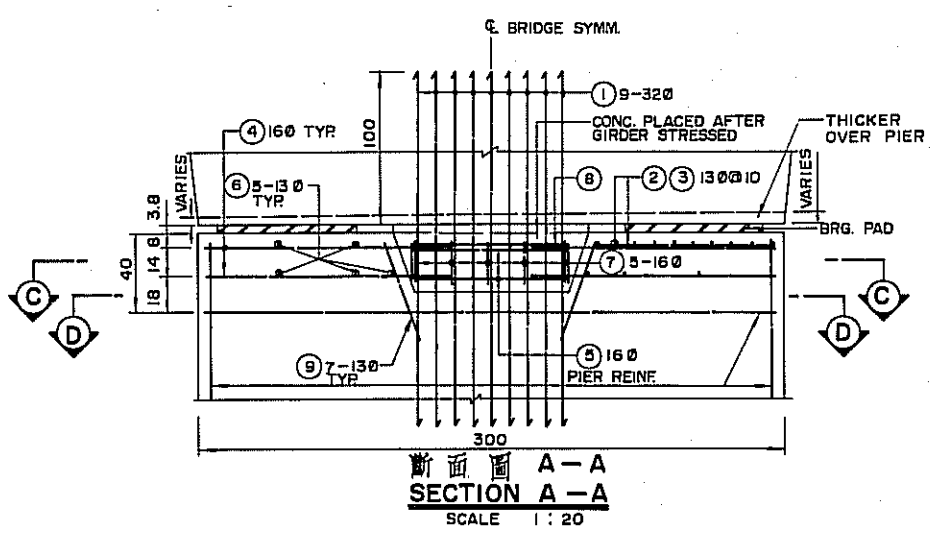
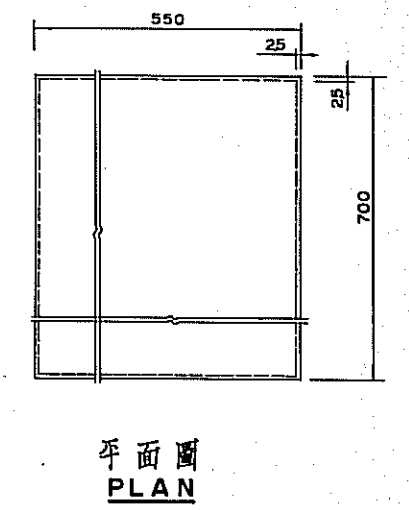
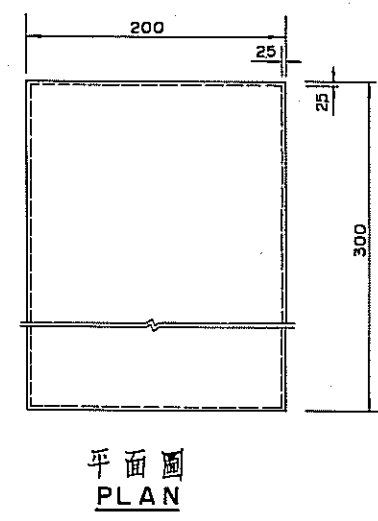
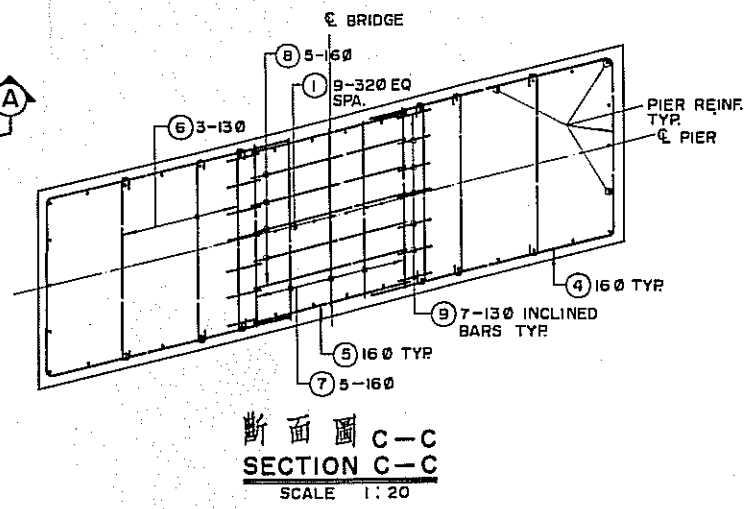
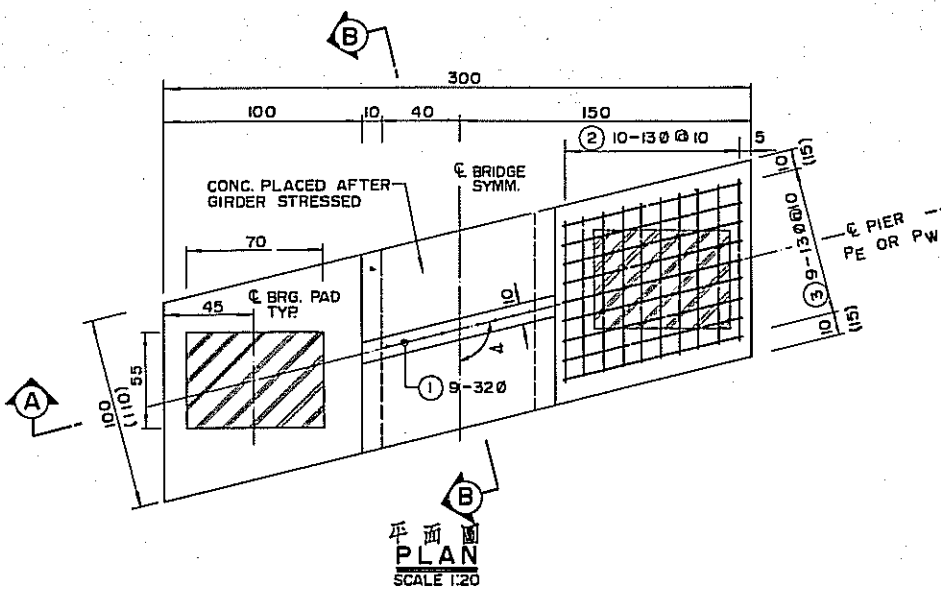

引道版處
AT APPROACH SLAB

橋墩處
AT PIER

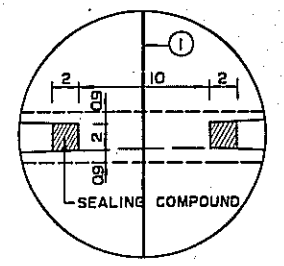
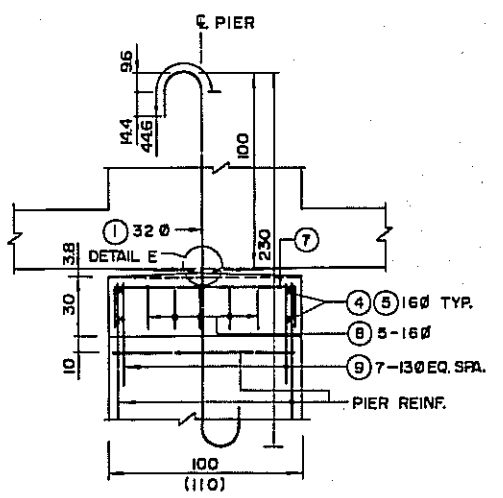

鉸接詳圖
HINGE CONNECTION DETAILS

鋼筋表
LIST OF REINFORCING STEELS

SHAPE	NOMINAL DIA. (MM)	REMARK
①	320	LENGTH=300
②	130	@ 10
③	130	@ 10
④	160	
⑤	160	
⑥	130	
⑦	160	
⑧	160	
⑨	130	LENGTH=50

合成橡膠支承版詳圖
ELASTOMERIC BEARING PAD DETAILS
SCALE 1:3
ALL DIMENSIONS ARE IN MM.

說明:
請說明參照圖 SO-36.
NOTE:
FOR GENERAL NOTES SEE SHEET SO-36.

修正 REVISIONS	項目 ITEM	日期 DATE	說明 REMARKS

PROJECT 60
交通部台灣區高速公路工程局
TAIWAN AREA FREEWAY CONSTRUCTION BUREAU
中華民國
REPUBLIC OF CHINA
南北高速公路
NORTH-SOUTH FREEWAY
苗栗台中段
MIAOLI-TAICHUNG SECTION
跨越橋
OVERCROSSING
鉸接及支承版詳圖
HINGE CONNECTION & BRG. PAD
DETAILS
中華顧問工程司
CHINA ENGINEERING CONSULTANTS, INC.
日期 DATE AUG. '74 比例 SCALE AS SHOWN 圖號 SHEET SO-31

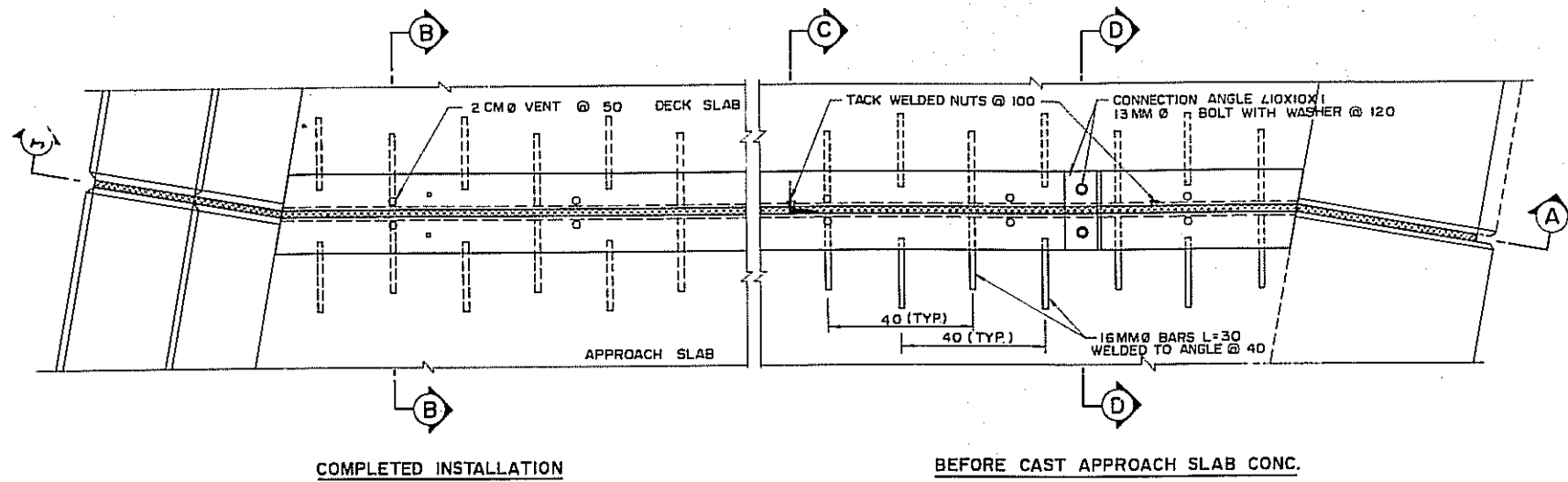

平面圖
PLAN
SCALE 1:10

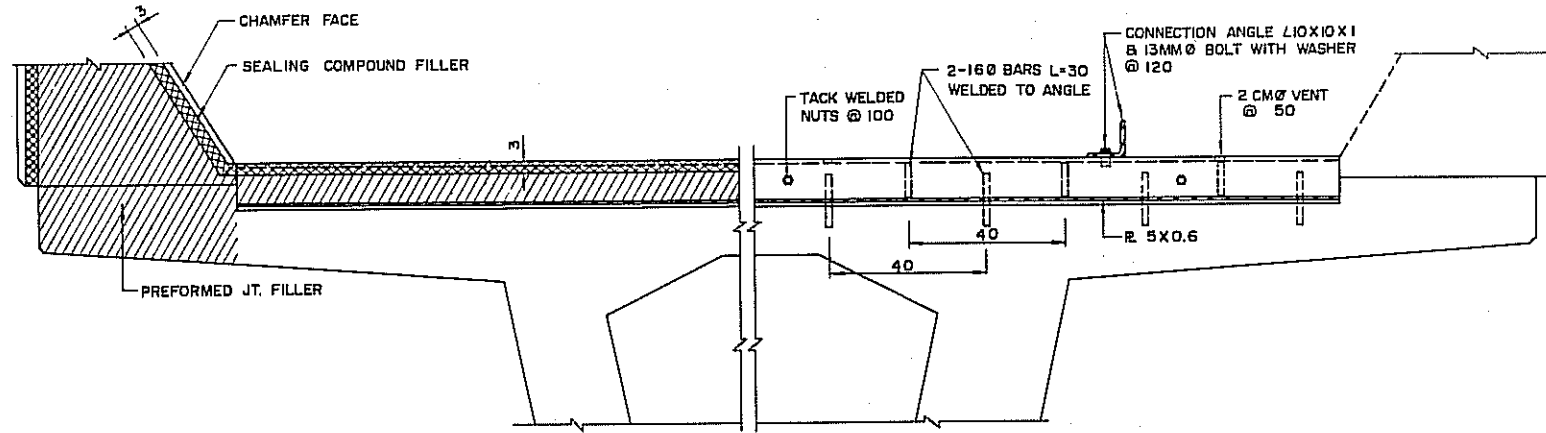

斷面圖 A—A
SECTION A—A
SCALE 1:10

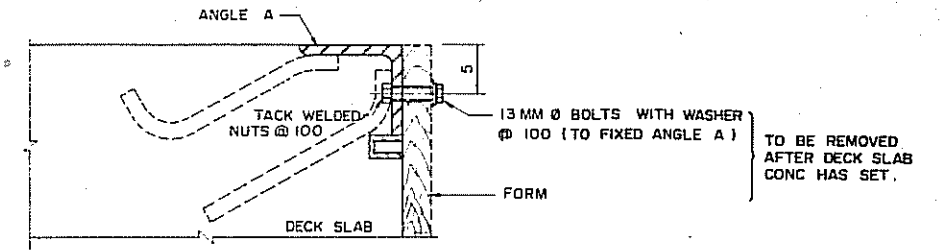

斷面圖 C
SECTION C.
SCALE 1:4

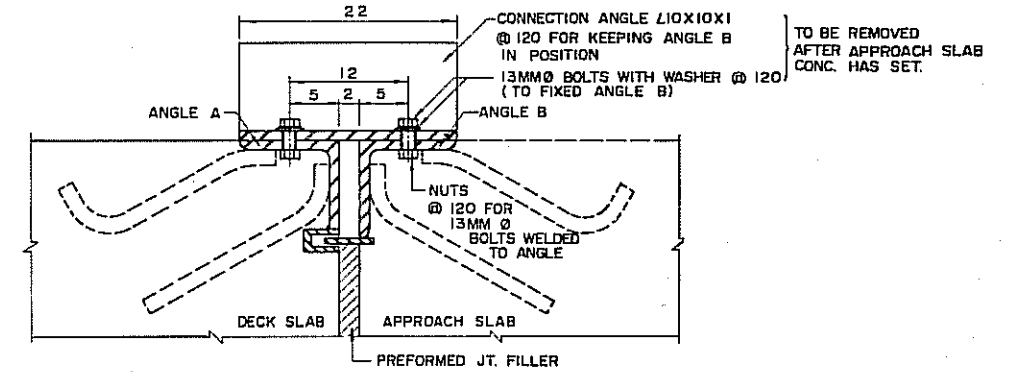

斷面圖 D—D
SECTION D—D
SCALE 1:4

說明:

1. 各項尺寸除另有註明者外，單位均以公分計。
2. 角鐵及鋼板均須合於 ASTM-A36 之規定。
3. 鋼鐵組件須經熱浸鍍鋅處理。
4. 焊接材料及方法須合於 AWS 出版之“公路及鐵路橋之焊接規範”。
5. 伸縮縫頂板須與路面坡度一致。

NOTES:

1. ALL DIMENSIONS ARE IN CM UNLESS OTHERWISE NOTED.
2. ANGLE & PLATES SHALL BE MILD STEEL CONFORMING TO ASTM A-36.
3. STEEL COMPONENTS SHALL BE HOT DIP GALVANIZED AFTER FABRICATION.
4. WELDING MATERIAL AND METHODS SHALL CONFORM TO AWS SPECIFICATION FOR WELDED HIGHWAY & RAILWAY BRIDGES.
5. THE TOP FACE OF EXPANSION JOINT SHOULD COINCIDE ROADWAY GRADE.

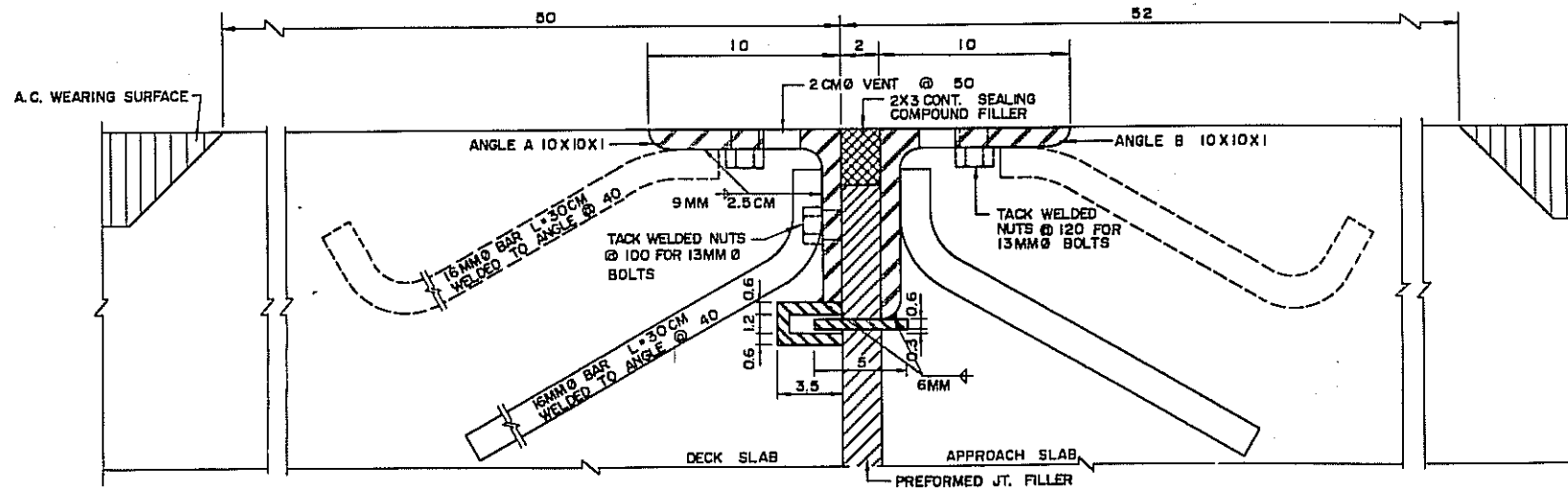

斷面圖 B—B
SECTION B—B
SCALE 1:2

PROJECT 60

修正 REVISIONS	項目 ITEM	日期 DATE	交通部台灣區高速公路工程局 TAIWAN AREA FREEWAY CONSTRUCTION BUREAU 中華民國 REPUBLIC OF CHINA
			南北高速公路 苗栗台中段 NORTH-SOUTH FREEWAY MIAOLI-TAICHUNG SECTION
			跨越橋 伸縮縫詳圖 OVERCROSSING EXPANSION JOINT DETAILS
			中華顧問工程司 CHINA ENGINEERING CONSULTANTS, INC.
			日期 DATE AUG. '74 比例 SCALE AS SHOWN 圖號 SHEET 50-32

預鑄邊溝詳圖
PRECAST GUTTER DETAILS

N.T.S.
(NOT APPLICABLE)

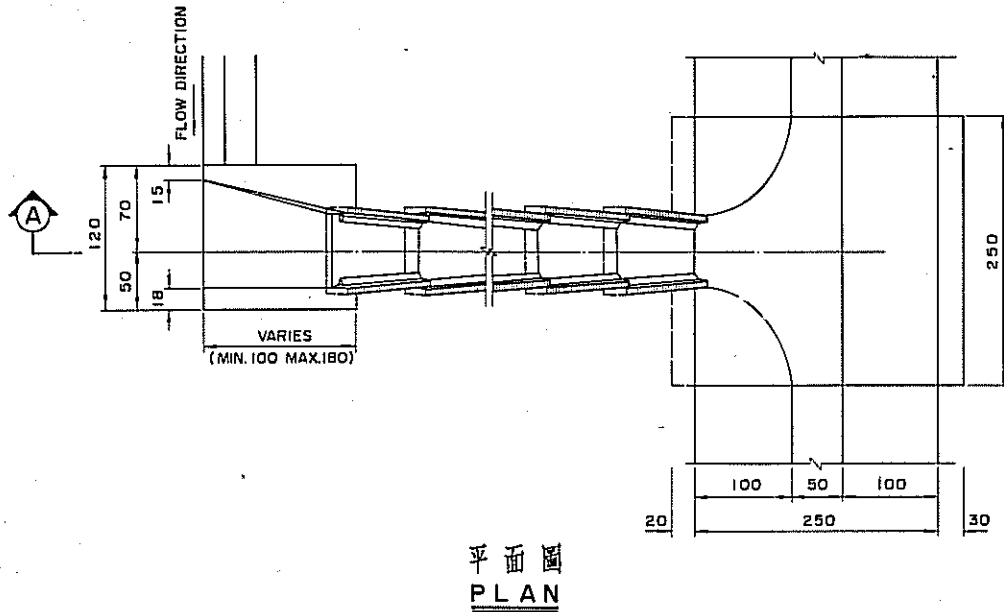

平面圖
PLAN

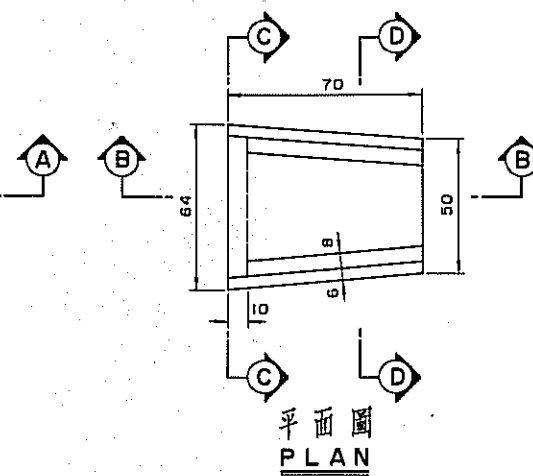

平面圖
PLAN

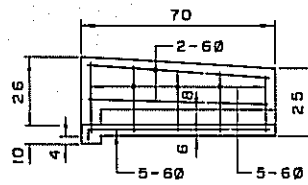

斷面圖 B-B
SECTION B-B

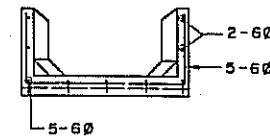

斷面圖 C-C
SECTION C-C

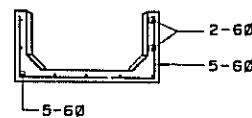

斷面圖 D-D
SECTION D-D

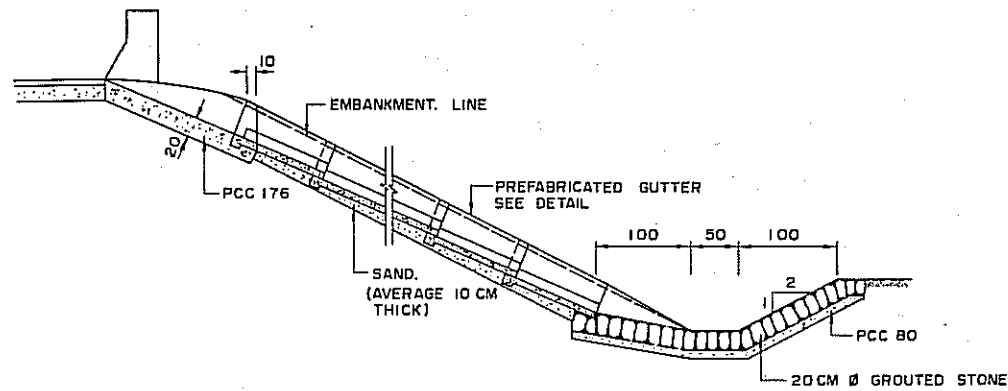

斷面圖 A-A
SECTION A-A

人行道鋼筋及伸縮縫詳圖
DETAIL FOR SIDEWALK REINFORCING & EXPANSION JOINT

SCALE 1:30

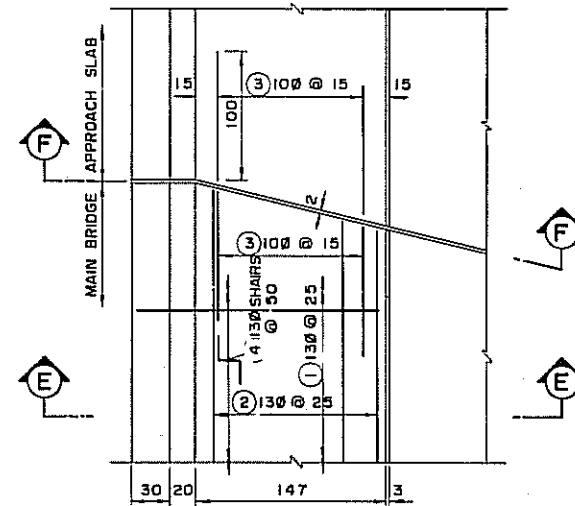

平面圖
PLAN

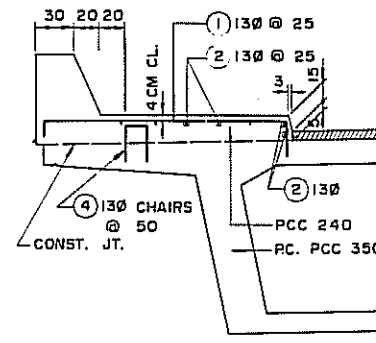

斷面圖 E-E
SECTION E-E

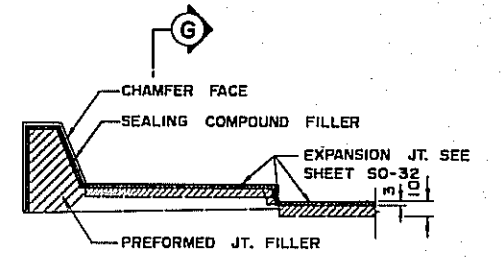

斷面圖 F-F
SECTION F-F

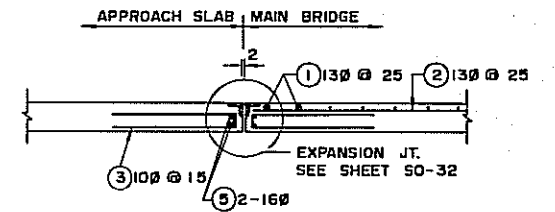

斷面圖 G-G
SECTION G-G

鋼筋表
LIST OF REINFORCING STEELS

SHAPE	NOMINAL DIA. (MM)	REMARK
①	130	@ 25
②	130	@ 25
③	100	@ 15
④	130	@ 50
⑤	160	

說明:

總說明參照圖 SO-36。

NOTE:

FOR GENERAL NOTES SEE SHEET SO-36.

PROJECT 60

修正	REVISIONS	項目	ITEM	日期	DATE

交通部台灣區高速公路工程局
TAIWAN AREA FREEWAY CONSTRUCTION BUREAU
中華民國
REPUBLIC OF CHINA
南北高速公路
NORTH-SOUTH FREEWAY
苗栗台中段
MIAOLI-TAICHUNG SECTION
跨越橋
OVERCROSSING
人行道詳圖
SIDEWALK DETAILS
中華顧問工程司
CHINA ENGINEERING CONSULTANTS, INC.
日期 DATE AUG. '74 比例 SCALE AS SHOWN 圖號 SHEET SO-33

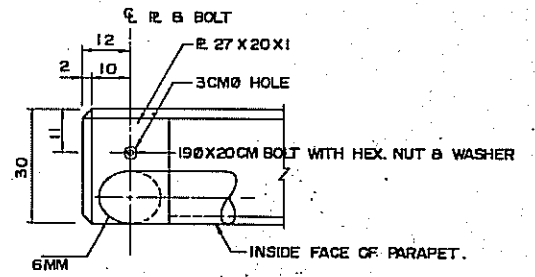
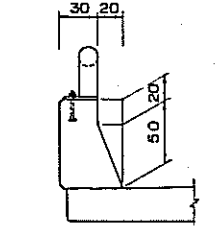
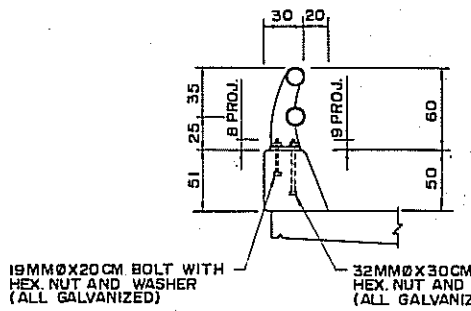
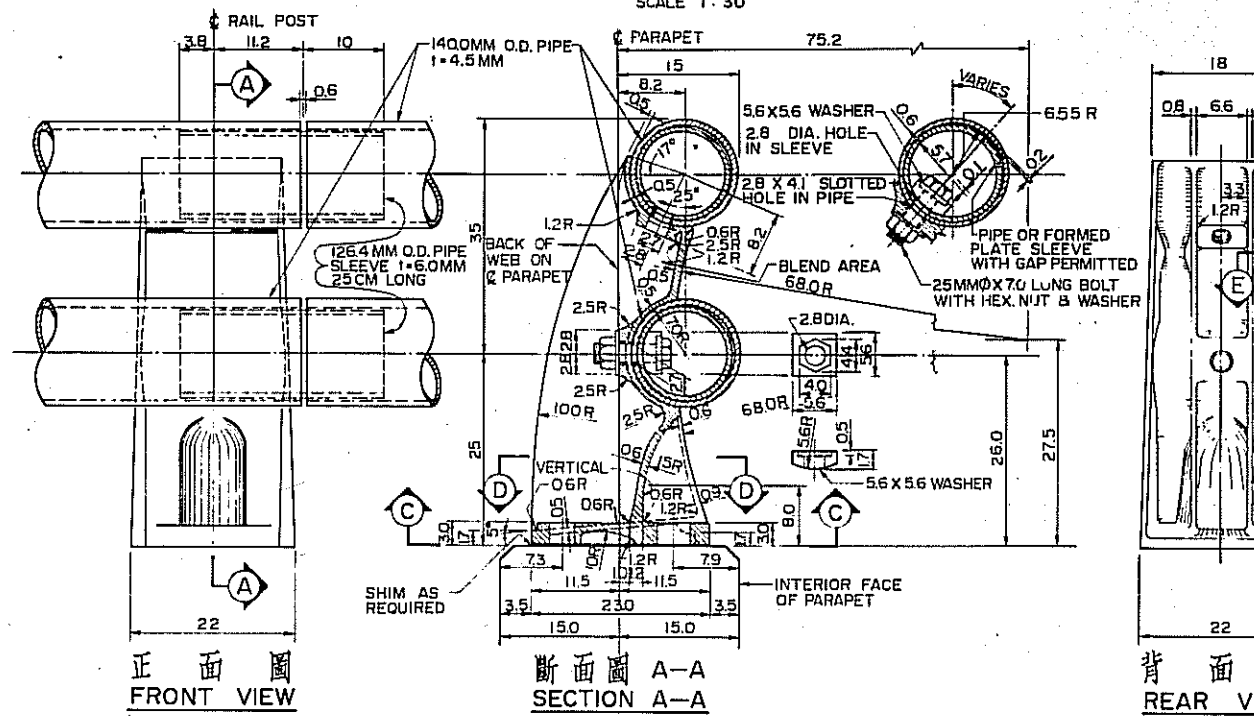
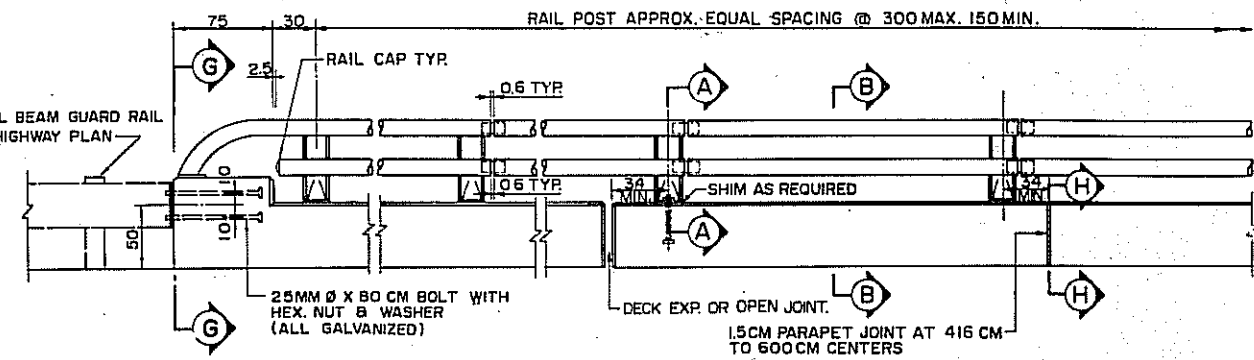
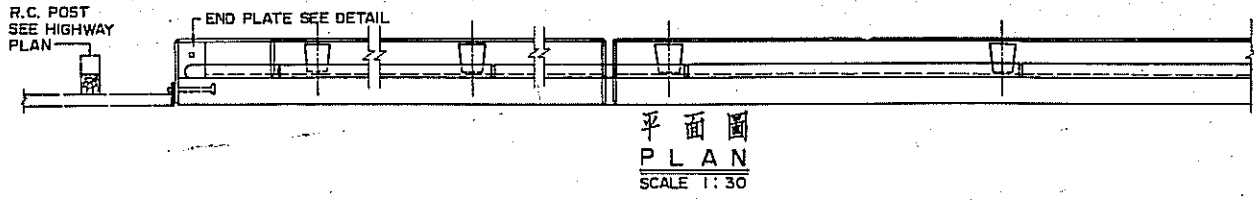

說明:

1. 欄杆材料可採用鋼鐵製或鋁合金製, 承包商可自行選定。
2. 若採用鋼鐵欄杆, 則於安裝前需將外露面全予鍍鋅。
3. 欄杆裝設於半徑小於 45 公尺之平面曲線時, 欄杆圓管及接頭套管應予準確彎曲, 以適合於該曲度。
4. 各項尺寸除另有註明者外, 均以公分 (CM) 計。

NOTES:

1. AT THE OPTION OF THE CONTRACTOR, MATERIAL FOR THE RAILING SHALL BE FERROUS OR ALUMINIOUS.
2. IF FERROUS RAILING IS ADOPTED, ALL EXPOSED PARTS SHALL BE GALVANIZED BEFORE ERECTION.
3. FOR RAILING ON A HORIZONTAL CURVE OF RADIUS LESS THAN 45 METERS, THE PIPE RAIL AND SLEEVES SHALL BE DETAILED BENT TO FIT THE CURVE.
4. ALL DIMENSIONS ARE IN CM UNLESS OTHERWISE NOTED.

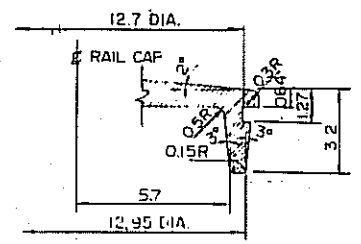

斷面圖 F-F SECTION F-F SCALE 1:15

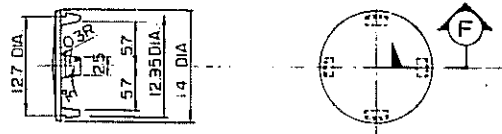
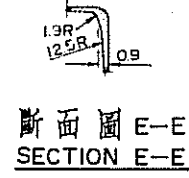

RAIL CAP SCALE 1:5

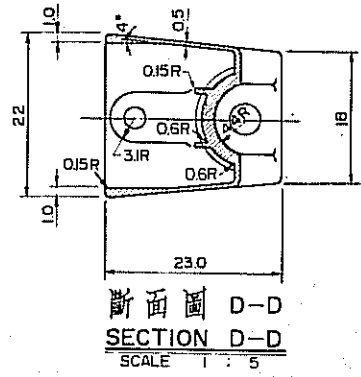
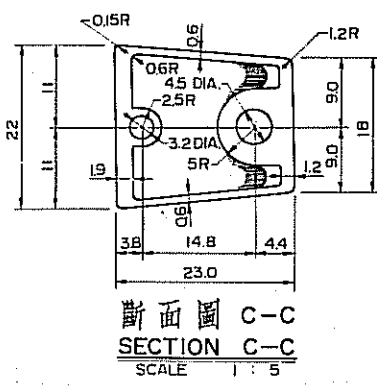
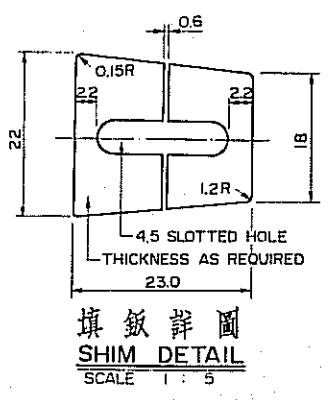

PROJECT 60

修正	REVISIONS	項目	ITEM	日期	DATE

交通部台灣區高速公路工程局
TAIWAN AREA FREEWAY CONSTRUCTION BUREAU
中華民國
REPUBLIC OF CHINA
南北高速公路 NORTH-SOUTH FREEWAY
苗栗中段 MIAOLI-TAICHUNG SECTION
跨越橋 OVERCROSSING
型式 II 金屬欄杆詳圖 TYPE II METAL RAILING DETAILS
中華顧問工程司 CHINA ENGINEERING CONSULTANTS, INC.
日期 DATE AUG. '74 比例 SCALE AS SHOWN 圖號 APPENDIX SO-34

鋼筋彎曲埋入及搭接長度表
TABLE FOR REINFORCING BARS BENDING, EMBEDMENT AND SPLICE

BAR SIZE	DIA. (MM.)	WEIGHT (KG/M)	AREA (CM ²)	MIN. EMBEDMENT LENGTH (CM)			MIN. LAP SPLICES LENGTH (CM)			STANDARD HOOK		STIRRUP & TIE HOOK A (CM.)
				COMP.	TENSION		COMP.	TENSION		180° HOOK A (CM)	90° HOOK A (CM)	
100	9.53	0.559	0.713	20	30	30	30	40	40	13	13	9
130	12.7	0.994	1.27	20	30	30	30	40	40	15	17	11
160	15.9	1.55	1.98	20	35	35	35	45	45	18	22	14
190	19.1	2.24	2.85	25	35	45	40	50	55	21	26	17
220	22.2	3.05	3.88	30	40	60	45	70	75	24	30	-
250	25.4	3.98	5.07	35	55	80	50	90	100	28	35	-
290	28.7	5.06	6.45	40	70	100	55	110	125	38	40	-
320	32.3	6.41	8.17	45	90	125	65	135	160	42	45	-
360	35.8	7.91	10.10	50	110	150	75	160	200	47	50	-

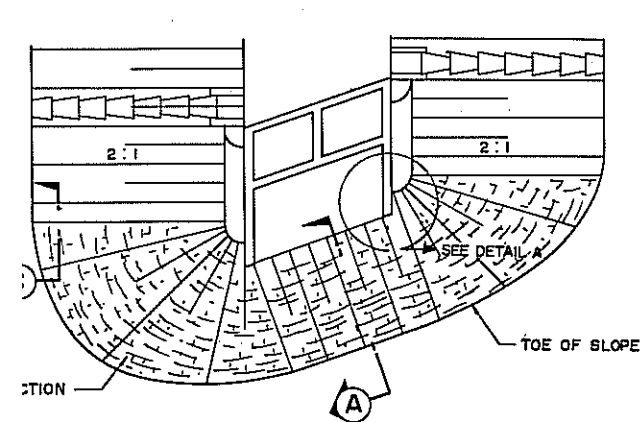

平面圖
PLAN

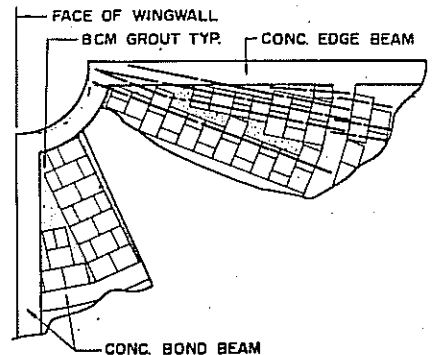

詳圖 A
DETAIL A
N.T.S.

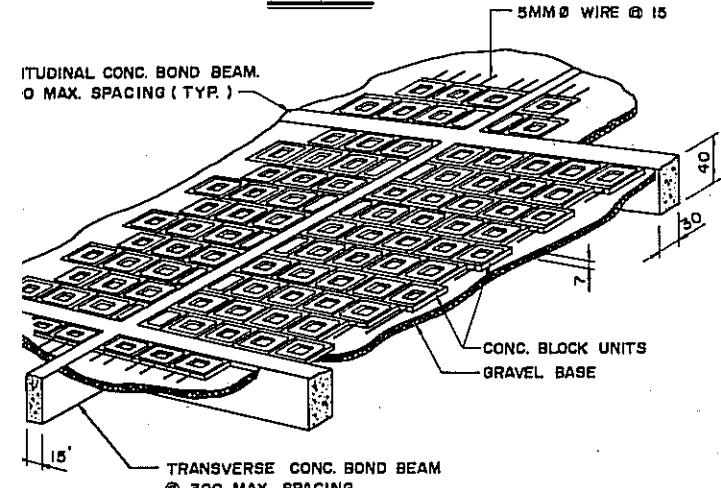

透視圖
PERSPECTIVE
N.T.S.

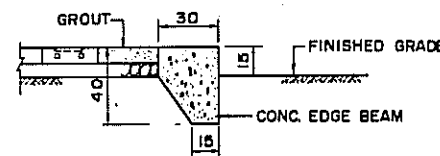

斷面圖 C—C
SECTION C—C
SCALE 1:20

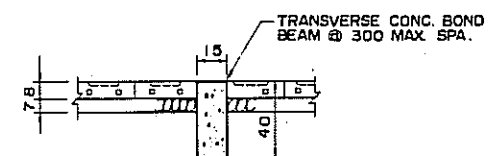

斷面圖 D—D
SECTION D—D
SCALE 1:20

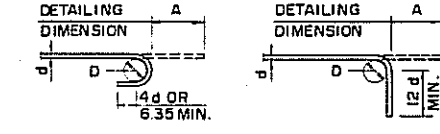

STANDARD HOOK
D = 6d FOR 100—250
8d FOR 290—360
(180°) (90°)

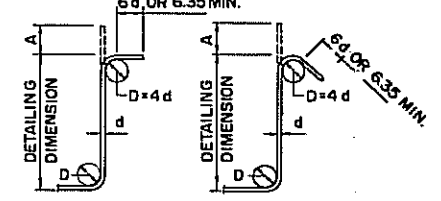

STIRRUP & TIE HOOK

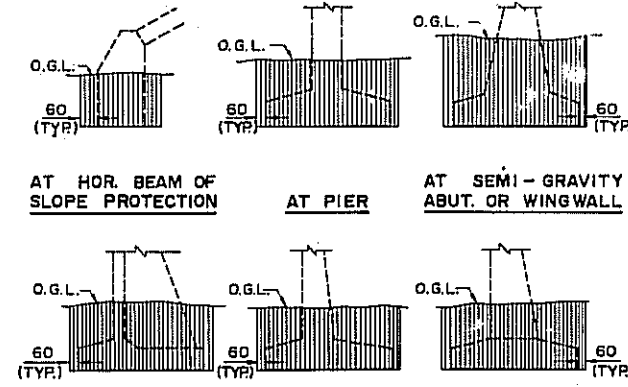

LIMITS FOR EXCAVATION OF STRUCTURES
LIMITS FOR BACKFILL OF STRUCTURES

說明:

- 總說明參照圖 50-36。
- 可用焊接或其他可行之連接方法以代替重疊搭接。當採用焊接時，所有焊接方法及材料均須符合規範 "AWS-D12.1" 之規定。
- 除工程師之准許外，所有鋼筋必須冷彎。
- 除圖面註明或工程師之准許外，不得將鋼筋部份埋入混凝土後再行彎曲之。
- 混凝土設計應力：混凝土塊單元： $f'_c = 240$ 公斤/平方公分。
東岸及基礎： $f'_c = 176$ 公斤/平方公分。

NOTES:

- FOR GENERAL NOTES SEE SHEET 50-36.
- WELDED SPLICES OR OTHER POSITIVE CONNECTIONS MAY BE USED INSTEAD OF LAPPED SPLICES AS PROVIDED HEREIN. ALL WELDING SHALL CONFORM TO AWS-D12.1 "RECOMMENDED PRACTICES FOR WELDING REINFORCING STEEL, METAL INSERTS AND CONNECTIONS IN REINFORCED CONCRETE CONSTRUCTION.
- ALL BARS SHALL BE BENT COLD, UNLESS OTHERWISE PERMITTED BY THE ENGINEER.
- NO BARS PARTIALLY EMBEDDED IN CONCRETE SHALL BE FIELD BENT EXCEPT AS SHOWN ON THE PLANS OR PERMITTED BY THE ENGINEER.
- CONCRETE DESIGN STRESSES: CONCRETE BLOCK UNIT: $f'_c = 240$ KG/CM²
BOND BEAM & FOOTING: $f'_c = 176$ KG/CM²

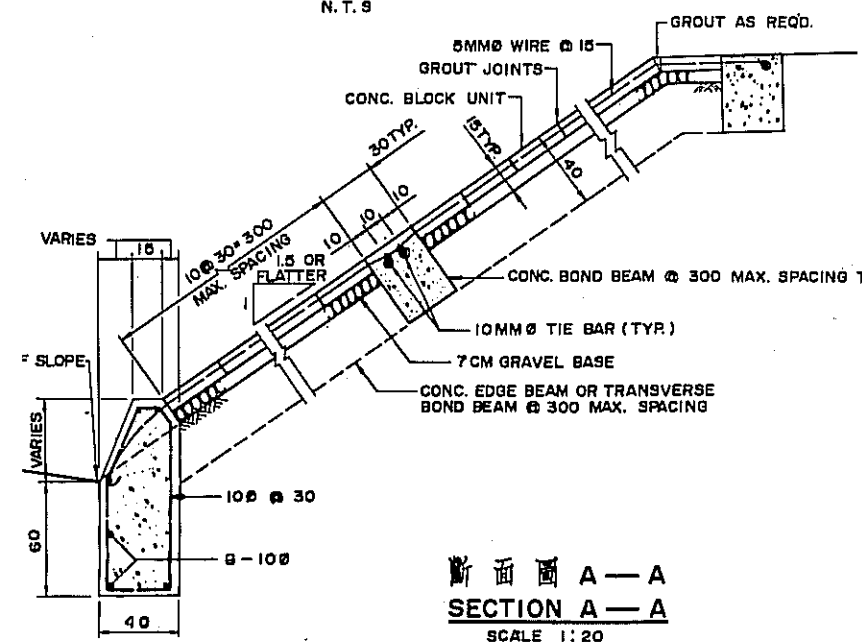

斷面圖 A—A
SECTION A—A
SCALE 1:20

護坡詳圖
SLOPE PROTECTION DETAIL

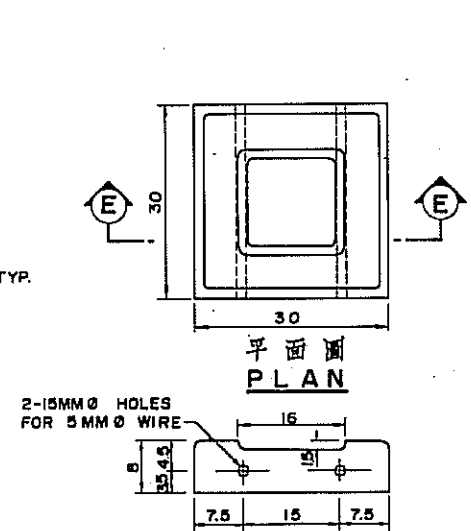

斷面圖 E—E
SECTION E—E

混凝土塊單元
CONC. BLOCK UNIT
SCALE 1:6

修正	REVISIONS	項目	ITEM	日期	DATE

交通部台灣區高速公路工程局
TAIWAN AREA FREEWAY CONSTRUCTION BUREAU
中華民國
中華人民共和國
南北高速公路
NORTH-SOUTH FREEWAY
苗栗台中段
MIAOLI-TAICHUNG SECTION
跨越橋
OVERCROSSING
護坡及雜項詳圖
SLOPE PROTECTION & MISC. DETAILS
中華顧問工程司
CHINA ENGINEERING CONSULTANTS, INC.
日期 DATE AUG. '74 比例 SCALE AS SHOWN 圖號 SHEET 50-35

PROJECT 60

總說明

- 設計規範：美國公路協會 1969 年之“公路橋樑標準規範”及 1971 年“中期規範”。
- 設計活載重：HS 20-44。
- 地震力：靜載重之 15%。
- 設計應力：
 - 無筋混凝土(基礎下)： $f'_c = 80 \frac{\text{kg}}{\text{cm}^2}$
 - 鋼筋混凝土：
 - 下部結構、引道版及護牆： $f'_c = 240 \frac{\text{kg}}{\text{cm}^2}$
 $f_c = 96 \frac{\text{kg}}{\text{cm}^2}$
 - 預力混凝土：見預力混凝土箱樑說明。
 - 鋼筋： $f_s = 1400 \frac{\text{kg}}{\text{cm}^2}$
 - 預力鋼纜：見工程局“標準規範”。
- 各項尺寸除另有註明者外，單位均以公分(CM)計。
- 鋼筋均採用竹節鋼筋。
- 鋼筋之彎製續接及埋置，除另行註明者外，均按圖 SO-35 標準詳細圖辦理。
- 鋼筋之淨保護層除另有註明者外，依下列規定：

橋面版及引道版	2.5 公分
樑及隔樑	4 公分
護牆	4 公分
下部結構	5 公分
其他	5 公分
- 混凝土外露之稜緣除另有規定外，均須設 2 公分之稜角。
- 簡寫字表示如下：

F.F. — 前面	R.F. — 後面	E.F. — 每面
BRG. — 支承	EQ. SPA. — 等間距	
- 橋面曲線變化之各相關尺寸及高度，須由承包商詳細計算繪圖並經工程司審核後方可施工。
- 倘基礎之容許承載力小於設計圖所註明之設計最大基礎壓力，則基礎之深度或大小，應受工地工程司之指示變更之。
- 承包商應查對設計圖所註所有各部尺寸及高度，如發現任何不符之處，應於施工前通知工程司修正。
- 鷹架應妥為設計，以防止因過大或不均勻沉陷而引起混凝土破裂。
- 橋近橋墩處之鷹架，應設計使之能將所有垂直荷重直接傳於橋墩。
- 施預力完成後，鷹架應由鷹架樑端及樑中間向橋墩方向逐步完全拆除。
- 上部結構接板，應參考各橋鋼樑佈置詳圖上所示之持力示意圖調整其高度，曲線詳細計算應由承包商提交工程司審核後方可施工。

GENERAL NOTES

- DESIGN SPECIFICATIONS: AASHTO "STANDARD SPECIFICATIONS FOR HIGHWAY BRIDGES" 1969 AND "INTERIM SPECIFICATIONS" 1971.
- DESIGN LIVE LOAD: HS 20-44.
- EARTHQUAKE FORCE: 15% OF THE DEAD LOAD.
- DESIGN STRESSES:
 - PLAIN CONCRETE (UNDER FOUNDATION) $f'_c = 80 \text{ KG/CM}^2$
 - REINFORCED CONCRETE:

SUBSTRUCTURES, APPROACH SLAB, AND PARAPET.	$f'_c = 240 \text{ KG/CM}^2$	$f_c = 96 \text{ KG/CM}^2$
--	------------------------------	----------------------------
 - PRESTRESSED CONCRETE: SEE NOTES FOR P.C. BOX GIRDER.
 - REINFORCING STEEL BARS: $f_s = 1400 \text{ KG/CM}^2$
 - PRESTRESSING STEEL: SEE "STANDARD SPECIFICATIONS" TAFCB.
- ALL DIMENSIONS ARE IN CM UNLESS OTHERWISE NOTED.
- ALL REINFORCING STEELS SHALL BE DEFORMED BARS.
- FOR REINFORCING BAR BENDING, SPLICE AND EMBEDMENT DETAILS SEE STANDARD SHEET SO-35 UNLESS OTHERWISE NOTED.
- MIN. CLEAR COVER OF ANY REINFORCING BAR, UNLESS OTHERWISE SPECIFIED SHALL BE AS FOLLOWS:

DECK SLAB & APPROACH SLAB	2.5 CM
GIRDER & DIAPHRAGM	4 CM
PARAPET	4 CM
SUBSTRUCTURE	5 CM
OTHERS	5 CM
- ALL EXPOSED EDGES OF CONCRETE SHALL BE CHAMFERED 2 CM UNLESS OTHERWISE NOTED.
- ABBREVIATIONS OF WORDS ARE SHOWN AS FOLLOWS:

F.F. — FRONT FACE,	E.F. — EACH FACE,
R.F. — REAR FACE,	BRG. — BEARING,
EQ. SPA. — EQUAL SPACE.	
- GEOMETRY OF CURVED DECK SHALL BE CALCULATED BY THE CONTRACTOR AND SUBMITTED TO THE ENGINEER FOR APPROVAL
- IN CASE THE SOIL ALLOWABLE BEARING CAPACITY IS LESS THAN MAX. DESIGN FOUNDATION PRESSURE SPECIFIED IN THE DESIGN DRAWING, THE DEPTH OR DIMENSIONS OF FOOTING SHALL BE CHANGED BY THE SITE ENGINEER.
- THE CONTRACTOR SHALL VERIFY ALL DIMENSIONS AND ELEVATIONS SHOWN ON THE PLANS AND SHALL NOTIFY THE ENGINEER OF ANY AND ALL DISCREPANCIES PRIOR TO THE BEGINNING OF THE WORK.
- THE FALSEWORK SHALL BE SUITABLY DESIGNED TO PREVENT LARGE OR UNEQUAL SETTLEMENT WHICH WOULD CAUSE CRACKING OF THE CONCRETE.
- THE FALSEWORK ADJACENT TO THE PIERS SHALL BE DESIGNED TO TRANSMIT THE FULL VERTICAL LOADS DIRECTLY TO THE PIERS.
- UPON COMPLETION OF PRESTRESSING, THE FALSEWORK SHALL BE FULLY RELEASED GRADUALLY AND UNIFORMLY FROM CONTI-LIVER ENDS AND MIDSPAN TOWARDS THE PIER.
- FORM FOR THE SUPERSTRUCTURE SHALL BE ADJUSTED IN ELEVATION TO PRODUCE THE REQUIRED INITIAL NEGATIVE CAMBER AS SHOWN ON THE PLAN OF TENDON LAYOUT DETAIL FOR EACH BRIDGE THE CONTRACTOR SHALL SUBMIT THE EXACT CALCULATION OF NEGATIVE CAMBER TO THE ENGINEER FOR APPROVAL BEFORE WORK BEGINNING.

預力混凝土箱樑之說明

- 所用後拉工法應經工程司之核可。
- 後拉法應採用經許可之端錨設施。
- 後拉法預力混凝土之鋼纜須為高拉力、冷拉、經消力熱處理者，其保證最小極限強度須符合工程司“標準規範”之有關規定。
- 鋼纜應置於不漏漿之柔性金屬套管內，端錨應設有孔道以為灌漿通入套管之端，所有鋼纜應為整支連續，不得續接或加用連接器。
- P_f = 在箱樑中央斷面之有效預力(預力箱樑所有損失發生後所保留之預力)。
 P_i = 在箱樑中央斷面之起始預力。
- 承包商在施事前應將鋼纜及端錨之排列細節、伸長度及千斤頂所施預力之計算，提送工程司核可。
- 計算後拉預力樑在端錨千斤頂所施預力應包括千斤頂所引起之損失、摩擦損失及彈性縮短損失，並依下述資料計算之：

曲線摩擦係數	$\mu = 0.25$
波浪式摩擦係數	$k = 0.0049/M$
彈性模數比	$n = 6$
- 上部結構樑應從兩端同時施預力。
- 所需混凝土抗壓強度除註明者外應如下：

28 天之強度	$f'_c = 350 \text{ 公斤/平方公分}$
施預力時之強度	$f'_{ci} = 280 \text{ 公斤/平方公分}$
- 每一套管於鄰近橋墩處，在樑之上端各置一通氣孔，如鋼樑佈置詳圖所示。
- 端錨與樑端間之凹處，用混凝土填塞。
- 箱樑混凝土之灌注可分為底版、梁腹、頂版三階段。版與樑腹接觸面應加設剪力樑或由人工處理成粗糙面。

NOTES FOR PRESTRESSED CONCRETE BOX GIRDER

- THE POST-TENSIONING SYSTEM TO BE USED SHALL BE APPROVED BY THE ENGINEER.
- AN APPROVED METHOD OF POSITIVE END ANCHORAGE SHALL BE PROVIDED FOR POST-TENSIONING.
- TENDONS FOR POST-TENSIONING PRESTRESSED CONCRETE SHALL CONSIST OF HIGH TENSILE, COLD DRAWN, STRESS RELIEVED WIRE HAVING A GUARANTEED MINIMUM ULTIMATE STRENGTH AS SPECIFIED IN "STANDARD SPECIFICATIONS" OF TAFCB.
- TENDONS SHALL BE ENCLOSED IN MORTAR-TIGHT FLEXIBLE METAL CONDUITS. ANCHORAGE SHALL PROVIDE FOR GROUT PASSAGE THROUGH THE CONDUIT. ALL TENDONS SHALL BE FURNISHED IN CONTINUOUS LENGTHS WITHOUT SPLICES OR COUPLINGS.
- P_f = EFFECTIVE PRESTRESSING FORCE (THE FORCE OF P.C. BOX GIRDER REMAINING AFTER ALL LOSSES HAVE OCCURRED) AT MID SECTION OF BOX GIRDER.
 P_i = INITIAL PRESTRESSING FORCE AT MID SECTION OF BOX GIRDER.
- THE CONTRACTOR SHALL SUBMIT TENDON AND ANCHORAGE ARRANGEMENT DETAILS, ELONGATION JACKING CALCULATION TO THE ENGINEER FOR APPROVAL BEFORE WORK BEGINNING.
- THE CALCULATION OF JACKING FORCE AT THE END OF POST-TENSIONING GIRDER SHOULD INCLUDING THE JACKING LOSS, FRICTION LOSS AND ELASTIC SHORTENING LOSS. THE FOLLOWING DATA ARE USED FOR CALCULATION.

CURVATURE FRICTION COEFFICIENT	$\mu = 0.25$
WOBBLE COEFFICIENT	$k = 0.0049/M$
ELASTIC MODULUS RATIO	$n = 6$
- THE SUPERSTRUCTURE OF BOX GIRDER SHALL BE POST-TENSIONED FROM BOTH ENDS SIMULTANEOUSLY.
- REQUIRED COMPRESSIVE STRENGTH SHALL BE AS FOLLOWS, UNLESS OTHERWISE NOTED.

AT 28 DAYS	$f'_c = 350 \text{ KG/CM}^2$
AT TIME OF PRESTRESSING	$f'_{ci} = 280 \text{ KG/CM}^2$
- EACH DUCT SHALL BE PROVIDED WITH 2 INTERMEDIATE VENTS AT THE TOP OF THE GIRDER ONE NEAR EACH PIER AS SHOWN ON THE PLAN OF TENDON LAYOUT DETAILS FOR EACH BRIDGE.
- THE RECESSES FOR THE ANCHORS SHALL BE FILLED WITH PORTLAND CEMENT CONCRETE.
- CONCRETE IN BOX GIRDER MAY BE PLACED IN THREE SEPARATE OPERATIONS, AS BOTTOM SLAB, WEBS, TOP SLAB. THE BOND BETWEEN SLABS AND WEBS SHALL BE POSITIVE AND MECHANICAL AND SECURED BY MEANS OF SHEAR KEY OR ARTIFICIALLY ROUGHENING THE CONCRETE SURFACE OF CONNECTION.

PROJECT 60

修正	REVISIONS	項目	ITEM	日期	DATE

交通部台灣區高速公路工程局	
TAIWAN AREA FREEWAY CONSTRUCTION BUREAU	
中華民國	
REPUBLIC OF CHINA	
南北高速公路	NORTH-SOUTH FREEWAY
苗栗台中段	MIAOLI-TAICHUNG SECTION
跨越橋	OVERCROSSING
總說明	GENERAL NOTES
中華顧問工程司	CHINA ENGINEERING CONSULTANTS, INC.
日期 DATE AUG. '74	比例 SCALE NONE
	圖號 SHEET SO-36

PROJECT 60

ITEM NO.	DESCRIPTION	STATION STRUCTURE TYPE	132+959.29	132+246.82	134+593.90	135+864.91	136+177.38	137+145.98	133+680.50	138+332							Σ
			UNDER CROSSING	OVER CROSSING	OVER CROSSING	OVER CROSSING	OVER CROSSING	OVER CROSSING	FLUME	FLUME	TRAFFIC BOXES						
1	STRUCTURE EXCAVATION	M ³	35740	230	392	310	380	353	2985	1280	447						42117
2	STRUCTURE BACKFILL	M ³	34742	136	286	220	240	250	766	782	202						37624
3	PERVIOUS BACKFILL	M ³															
4	80 KG/CM ² CONCRETE	M ³	126	12	12	27	16	12	26	7	61						299
5	176 KG/CM ² CONCRETE	M ³				45	40										85
6	240 KG/CM ² CONCRETE	M ³	1964	245	248	388	350	246	932	448	670						5491
7	WATER CONCRETE	M ³															
8	320 KG/CM ² CONCRETE	M ³															
9	350 KG/CM ² CONCRETE	M ³		171	171	340	300	171	713								1866
10	P. C. WIRE	MT.		7	7	15	11	7	20								67
11	PRECAST R.C.-GIRDER 7.6M	EA															
12	R.C.-GIRDER 17.80 M TYPE II	EA	10														10
13	R.C.-GIRDER 19.94 M TYPE IV	EA															
14	R.C.-GIRDER 19.94 M TYPE VIII	EA															
15	R.C.-GIRDER 21.94 M TYPE IV	EA															
16	R.C.-GIRDER 24.94 M TYPE IV SPA. 23M	EA															
17	R.C.-GIRDER 24.94 M TYPE IV SPA. 26M	EA															
18	R.C.-GIRDER 29.94 M TYPE V	EA															
19	R.C.-GIRDER 30.94 M TYPE VI	EA															
20	R.C.-GIRDER 33.94 M TYPE VII	EA															
21	R.C.-GIRDER 34.94 M TYPE VIII SPA. 235M	EA															
22	R.C.-GIRDER 34.94 M TYPE VIII SPA. 260M	EA															
23	R.C.-GIRDER 39.94 M TYPE VIII	EA															
24	STEEL REINFORCING BARS	MT	147	62	63	100	90	62	159	62	75						820
25	CONCRETE BLOCK SLOPE PROTECTION WITH 7CM GRAVEL BASE	M ²	1254	662	628	490	365	654			409						4462
26	ELASTOMERIC EXPANSION JOINT SEAL (FOR RIVER BRIDGE)	LM															
27	ELASTOMERIC EXPANSION JOINT SEAL	LM															
28	ANGLE EXPANSION JOINT	LM	53	16	16	27	24	16	24	9							185
29	RAILING TYPE I	LM	139														139
30	RAILING TYPE I	LM		120	120	132	120	120	166	121							899
31	PVC CONDUIT Ø 7.5 CM	LM															
32	SCUPPER	EA	4														4
33	PVC DRAIN PIPE Ø 20 CM	LM	36														36
34	STEEL CUTTING EDGE	MT															
35	SINKING OF CASSION 5.5 M Ø	LM															
36	SINKING OF CASSION 6.0 M Ø	LM															
37	SINKING OF CASSION 6.5 M Ø	LM															
38	SINKING OF CASSION 7.0 M Ø	LM															

PROJECT 60

修正	REVISIONS						
項目	ITEM	日期	DATE	交通部台灣區高速公路工程局 TAIWAN AREA FREEWAY CONSTRUCTION BUREAU 中華民國 REPUBLIC OF CHINA 南北高速公路 MIAOLI-TAICHUNG SECTION 苗栗台中段 結構數量表 LIST OF STRUCTURAL QUANTITIES 中華顧問工程司 CHINA ENGINEERING CONSULTANTS, INC. 日期 DATE AUG. 74 比例 SCALE NONE 圖號 SHEET SQ-1			

總說明

1. 設計規範：美國公路協會1969年之“公路橋標準規範”及1971年“中期規範”。
2. 設計活載重：HS 20—44。
3. 地震力：靜載重之15%。
4. 風速：180 公里/小時。
5. 設計應力：
 - A. 無筋混凝土(基礎下) $f'_c = 80$ 公斤/平方公分
 - B. 鋼筋混凝土
 - (a) 一般性 $f'_c = 240$ 公斤/平方公分
 $f_c = 96$ 公斤/平方公分
 - (b) 半重力式橋台 $f'_c = 176$ 公斤/平方公分
 $f_c = 70$ 公斤/平方公分
 - C. 預力混凝土：見預力樑說明。
 - D. 鋼筋： $f_s = 1400$ 公斤/平方公分
 - E. 預力鋼腱：見工程局“標準規範”。
6. 各項尺寸除另有註明者外，單位均以公分(CM)計。
7. 鋼筋均採用竹節鋼筋。
8. 鋼筋之銲製、接及埋置，除另行註明者外，均按圖 ST-12 標準詳細圖辦理。
9. 鋼筋之淨保護層除另有註明者外，依下列規定：

橋面版	2.5	公分
樑及隔樑	4	公分
護牆	4	公分
下部結構	5	公分
其他	5	公分
10. 混凝土外露之鐵絲除另行規定外，均須設2公分之彎角。
11. 簡寫字表示如下：
 - F.F.—前面， R.F.—後面， E.F.—每面，
 - BRG.—支承， T&B—頂與底， EQ.—地震相等。
12. 橋面曲線變化之各相關尺寸及高度，須由承包商詳細計算繪圖並經工程司審核後方可施工。
13. 窺腳基礎頭座於砂石層上，倘基礎之容許承載力小於設計圖所註明之設計最大基礎壓力，則基礎之深度或大小，應受工地工程司之指示變更之。
14. 承包商應查對設計圖所註所有各部尺寸及高度，如發現任何不符之處，應於施工前通知工程司修正。

GENERAL NOTES

1. DESIGN SPECIFICATIONS: AASHTO "STANDARD SPECIFICATIONS FOR HIGHWAY BRIDGES" 1969 AND "INTERIM SPECIFICATIONS" 1971.
2. DESIGN LIVE LOAD: HS 20-44.
3. EARTHQUAKE FORCE: 15% OF THE DEAD LOAD.
4. WIND VELOCITY: 180 KILOMETER PER HOUR.
5. DESIGN STRESSES:
 - A. PLAIN CONCRETE (UNDER FOUNDATION) $f'_c = 80$ KG/CM²
 - B. REINFORCED CONCRETE:
 - (a) GENERAL $f'_c = 240$ KG/CM²
 $f_c = 96$ KG/CM²
 - (b) SEMI-GRAVITY ABUTMENT $f'_c = 176$ KG/CM²
 $f_c = 70$ KG/CM²
 - C. PRESTRESSED CONCRETE: SEE NOTES FOR P.C. GIRDER.
 - D. REINFORCING STEEL BARS: $f_s = 1400$ KG/CM²
 - E. PRESTRESSING STEEL: SEE "STANDARD SPECIFICATIONS" TAFGB.
6. ALL DIMENSIONS ARE IN CM UNLESS OTHERWISE NOTED.
7. ALL REINFORCING STEELS SHALL BE DEFORMED BARS.
8. FOR REINFORCING BAR BENDING, SPLICE AND EMBEDMENT DETAILS SEE STANDARD SHEET ST-12 UNLESS OTHERWISE NOTED.
9. MIN. CLEAR COVER OF ANY REINFORCING BAR, UNLESS OTHERWISE SPECIFIED SHALL BE AS FOLLOWS:

DECK SLAB	2.5	CM
GIRDER & DIAPHRAGM	4	CM
PARAPET	4	CM
SUBSTRUCTURE	5	CM
OTHERS	5	CM
10. ALL EXPOSED EDGES OF CONCRETE SHALL BE CHAMFERED 2 CM UNLESS OTHERWISE NOTED.
11. ABBREVIATIONS OF WORDS ARE SHOWN AS FOLLOWS:
 - F.F.—FRONT FACE, E.F.—EACH FACE,
 - R.F.—REAR FACE, BRG.—BEARING,
 - T & B — TOP & BOTTOM, EQ.—EARTHQUAKE, EQUAL.
12. GEOMETRY OF CURVED DECK SHALL BE CALCULATED BY THE CONTRACTOR AND SUBMITTED TO THE ENGINEER FOR APPROVAL.
13. THE FOUNDATION OF SPREAD FOOTING SHOULD REST ON THE SAND GRAVEL STRATUM. IN CASE THE SOIL ALLOWABLE BEARING CAPACITY IS LESS THAN MAX. DESIGN FOUNDATION PRESSURE SPECIFIED IN THE DESIGN DRAWING. THE DEPTH OR DIMENSIONS OF FOOTING SHALL BE CHANGED BY THE SITE ENGINEER.
14. THE CONTRACTOR SHALL VERIFY ALL DIMENSIONS AND ELEVATIONS SHOWN ON THE PLANS AND SHALL NOTIFY THE ENGINEER OF ANY AND ALL DISCREPANCIES PRIOR TO THE BEGINNING OF THE WORK.

預力樑之說明

1. 所用後拉工法應經工程司之核可。
2. 後拉法應採用經許可之錨固設施。
3. 後拉法預力混凝土之鋼腱須為高拉力、冷拉、經消力熱處理者，其保證最小極限強度須符合工程局“標準規範”之有關規定。
4. 鋼腱應置於不滲漿之柔性金屬套管內，端錨應設有孔道以灌漿通入套管之端，所有鋼腱應為整支連續，不得續接或加用連接器。
5. P_i = 在樑中央斷面之有效預力(每支大樑所有損失發生後所保留之預力)。
 P_i = 在樑中央斷面之起始預力。
6. 承包商在工前應將鋼腱及端錨之排列細節、伸長度及千斤頂所施預力之計算，提送工程司核可。
7. 計算後拉預力樑在端點千斤頂所施預力應包括千斤頂所引起之損失、摩擦損失及彈性縮短損失，並依下述資料計算之：
 - 曲線摩擦係數 $\mu = 0.25$
 - 波浪式摩擦係數 $K = 0.0049$ /公尺
 - 彈性模數比 $n = 6$
8. 後拉預力大樑應在兩端同時施預力。
9. 所需混凝土抗壓強度除註明者外應如下所示：
 - 28天之強度 $f'_c = 350$ 公斤/平方公分
 - 施預力時之強度 $f'_{ci} = 280$ 公斤/平方公分
10. 端錨之銲製保護應如下述處理：
 - 先拉法樑：樑端暴露鋼腱應塗環氧粘着劑。
 - 後拉法樑：端錨與樑端間之凹處用混凝土填塞。
11. 吊樑之方法應經工程司之同意，吊樑應僅限於支承位置。
12. 如採用先拉法預力，承包商應於工前將設計詳細圖計算書送交工程司審定。

NOTES FOR PRESTRESSED CONCRETE GIRDER

1. THE POST-TENSIONING SYSTEM TO BE USED SHALL BE APPROVED BY THE ENGINEER.
2. AN APPROVED METHOD OF POSITIVE END ANCHORAGE SHALL BE PROVIDED FOR POST-TENSIONING.
3. TENDONS FOR POST-TENSIONING PRESTRESSED CONCRETE SHALL CONSIST OF HIGH TENSILE, COLD DRAWN, STRESS RELIEVED WIRE HAVING A GUARANTEED MINIMUM ULTIMATE STRENGTH AS SPECIFIED IN "STANDARD SPECIFICATIONS" OF TAFGB.
4. TENDONS SHALL BE ENCLOSED IN MORTAR-TIGHT FLEXIBLE METAL CONDUITS. ANCHORAGE SHALL PROVIDE FOR GROUT PASSAGE THROUGH THE CONDUIT. ALL TENDONS SHALL BE FURNISHED IN CONTINUOUS LENGTHS WITHOUT SPLICES OR COUPLINGS.
5. P_i = EFFECTIVE PRESTRESSING FORCE (THE FORCE PER GIRDER REMAINING AFTER ALL LOSSES HAVE OCCURRED) AT MID SECTION OF GIRDER.
 P_i = INITIAL PRESTRESSING FORCE AT MID SECTION OF GIRDER.
6. THE CONTRACTOR SHALL SUBMIT TENDON AND ANCHORAGE ARRANGEMENT DETAILS, ELONGATION AND JACKING FORCE TO THE ENGINEER FOR APPROVAL BEFORE WORK BEGINS.
7. THE CALCULATION OF JACKING FORCE AT THE END OF POST-TENSIONING GIRDER SHOULD INCLUDING THE JACKING LOSS, FRICTION LOSS AND ELASTIC SHORTENING LOSS. THE FOLLOWING DATA ARE USED FOR CALCULATION.

CURVATURE FRICTION COEFFICIENT	$\mu = 0.25$
WOBBLE COEFFICIENT	$K = 0.0049$ /M
ELASTIC MODULUS RATIO	$n = 6$
8. GIRDERS SHALL BE POST-TENSIONED FROM BOTH ENDS SIMULTANEOUSLY.
9. REQUIRED CONCRETE COMPRESSIVE STRENGTH SHALL BE AS FOLLOWS, UNLESS OTHERWISE NOTED.

AT 28 DAYS	$f'_c = 350$ KG/CM ²
AT TIME OF PRESTRESSING	$f'_{ci} = 280$ KG/CM ²
10. CORROSION PROTECTION OF END ANCHORAGES:
 - PRE-TENSIONED GIRDERS: EPOXY CEMENT SHALL BE DABBED TO COVER THE TENDONS AT THE END OF THE GIRDER.
 - POST-TENSIONED GIRDERS: THE RECESSES FOR THE ANCHORS SHALL BE FILLED WITH PORTLAND CEMENT CONCRETE.
11. THE TYPE OF LIFTING DEVICE TO BE USED SHALL BE APPROVED BY THE ENGINEER. GIRDERS ARE TO BE LIFTED AT BEARING POINTS ONLY.
12. IF PRE-TENSIONING SYSTEM IS ADOPTED. THE CONTRACTOR SHALL SUBMIT PLANS AND STATICAL CALCULATIONS FOR APPROVAL TO THE ENGINEER BEFORE WORK BEGINS.

STD. DETAILS FOR U/C & CHANNEL BRIDGE

修正 項目	REVISIONS 日期 DATE	交通部台灣區高速公路工程局 TAIWAN AREA FREEWAY CONSTRUCTION BUREAU 中華民國 REPUBLIC OF CHINA
		南北高速公路 苗栗台中段 NORTH-SOUTH FREEWAY MIAOLI-TAICHUNG SECTION
		總說明及預力樑說明 GENERAL NOTES & NOTES FOR P.C. GIRDER
		中華顧問工程司 CHINA ENGINEERING CONSULTANTS, INC.
		日期 DATE AUG. '74 比例 SCALE NONE 圖號 SHEET ST-1

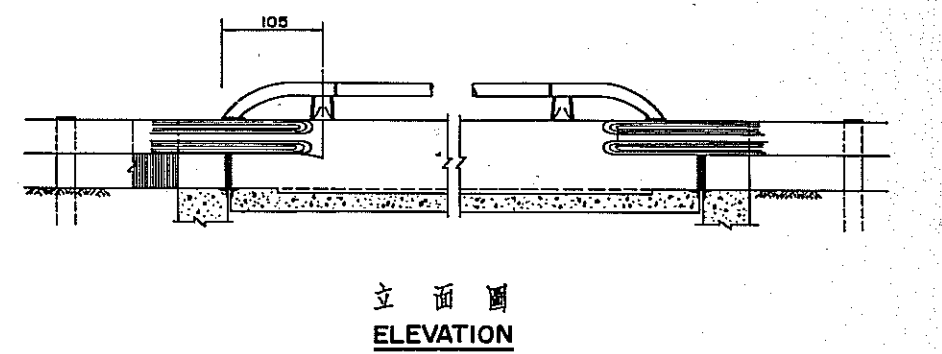
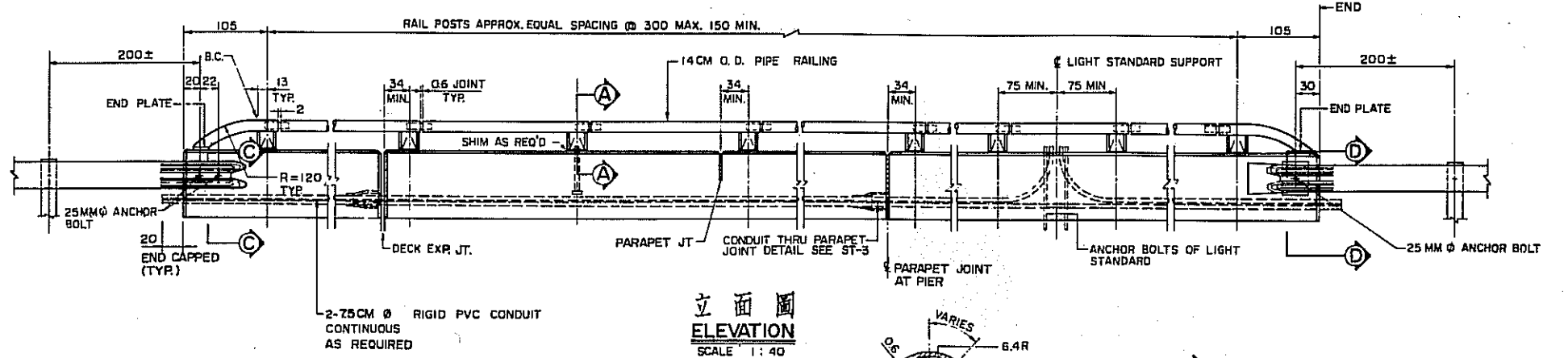
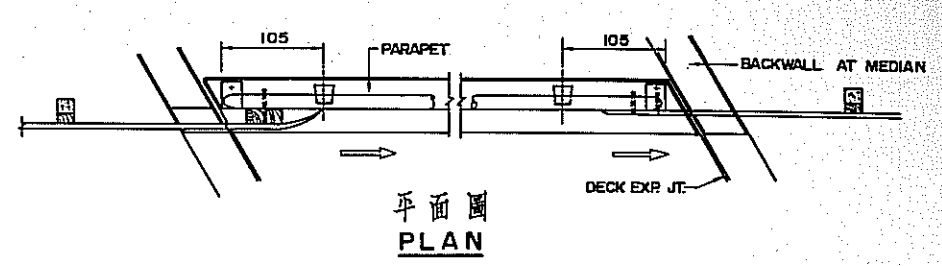
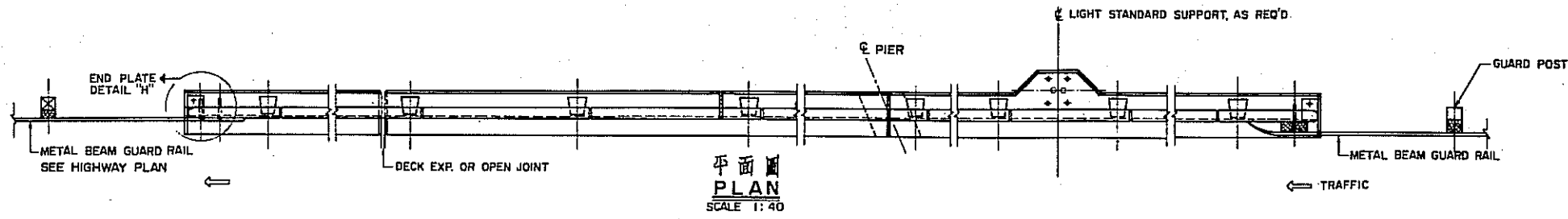

中間島欄杆端部
END RAILING AT MEDIAN
SCALE 1:40

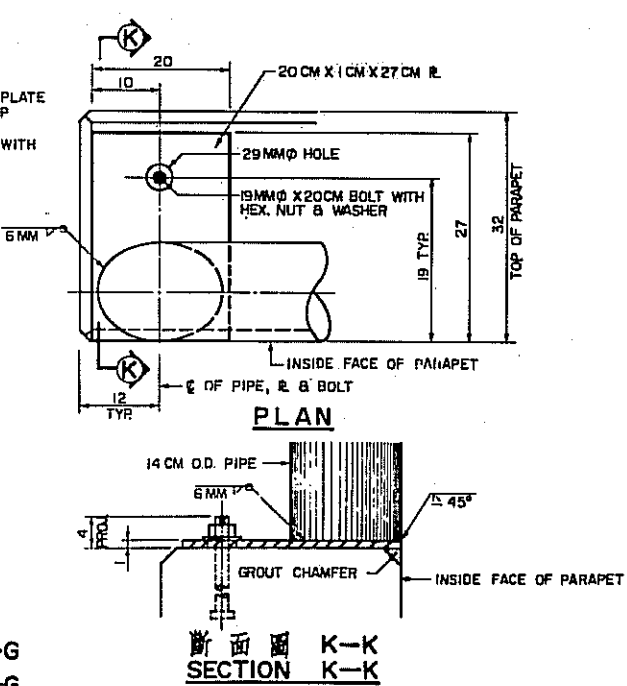
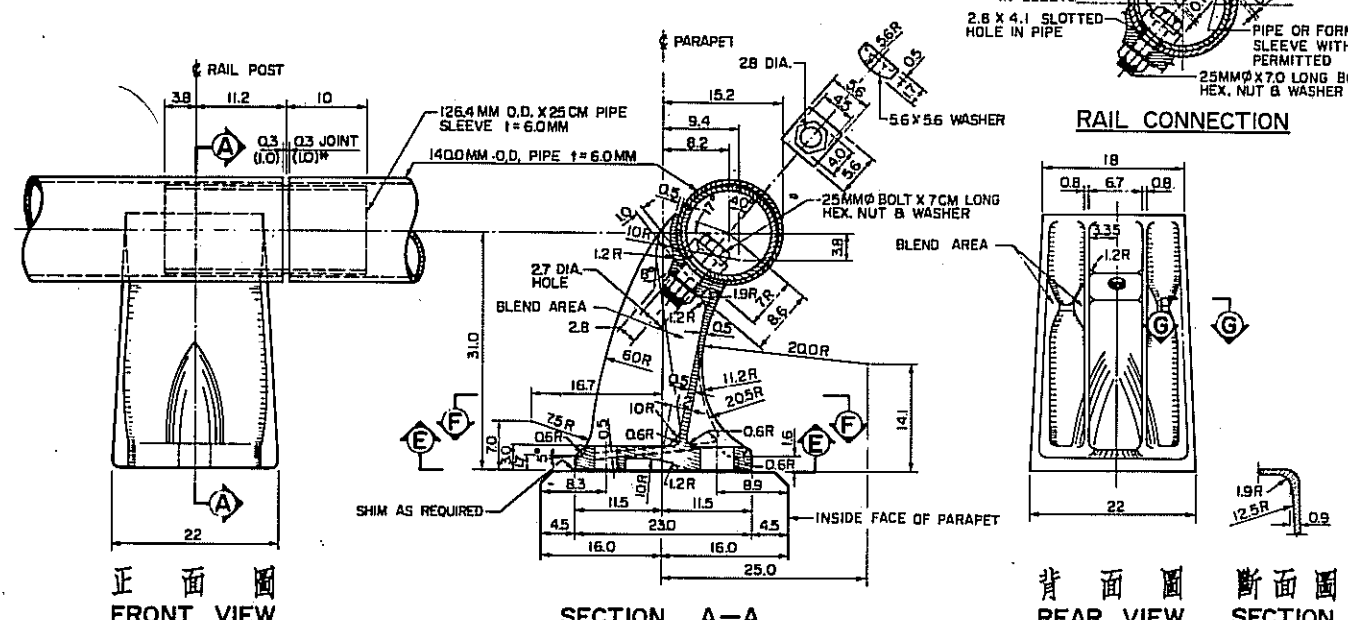

- NOTES:
1. AT THE OPTION OF THE CONTRACTOR, MATERIAL FOR THE RAILING SHALL BE FERROUS OR ALUMINOUS.
 2. IF FERROUS RAILING IS ADOPTED, ALL EXPOSED PARTS SHALL BE GALVANIZED BEFORE ERECTION.
 3. FOR RAILING ON A HORIZONTAL CURVE OF RADIUS LESS THAN 45 METERS, THE PIPE RAIL AND SLEEVES SHALL BE DETAILED BENT TO FIT THE CURVE.
 4. DIRECTION OF TRAFFIC INDICATED BY \Rightarrow .
 5. ALL DIMENSIONS ARE IN CM UNLESS OTHERWISE NOTED.

- 說明:
1. 欄杆材料可採用鋼鐵製或鋁合金製，承包商可自行選定。
 2. 若採用鋼鐵欄杆，則於安裝前需將外露面全予鍍鋅。
 3. 欄杆裝設於半徑小於45公尺之平面曲線時欄杆圓管及接頭套管應予準確彎曲，以適合於該曲度。
 4. 行車方向以 \Rightarrow 表示之。
 5. 各項尺寸除另有註明者外，均以公分(CM)計。

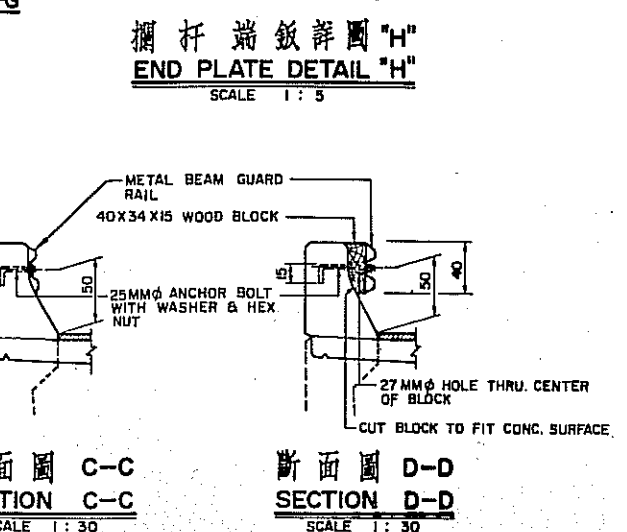
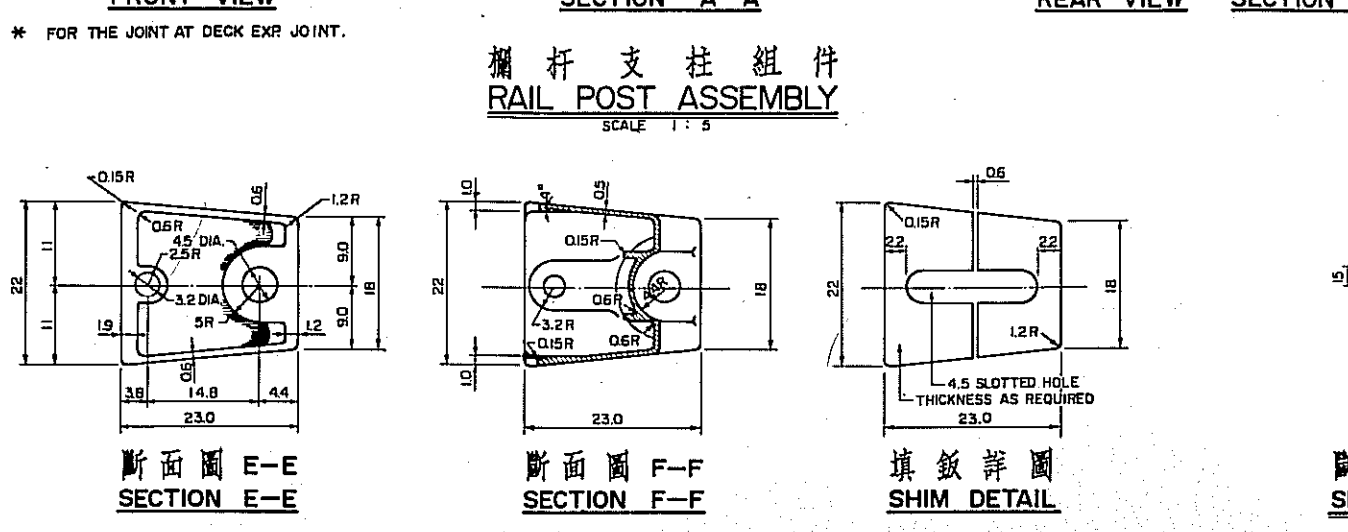

修正 REVISIONS		項目 ITEM		日期 DATE

STD. DETAILS FOR U/C & CHANNEL BRIDGE

交通部台灣區高速公路工程局
TAIWAN AREA FREEWAY CONSTRUCTION BUREAU
中華民國
REPUBLIC OF CHINA

南北高速公路
苗栗台中段
NORTH-SOUTH FREEWAY
MIAOLI-TAICHUNG SECTION

型式I金屬欄杆詳圖
TYPE I
METAL RAILING DETAILS

中華顧問工程司
CHINA ENGINEERING CONSULTANTS, INC.

日期 DATE AUG. '74 比例 SCALE AS SHOWN 圖號 SHEET ST-2

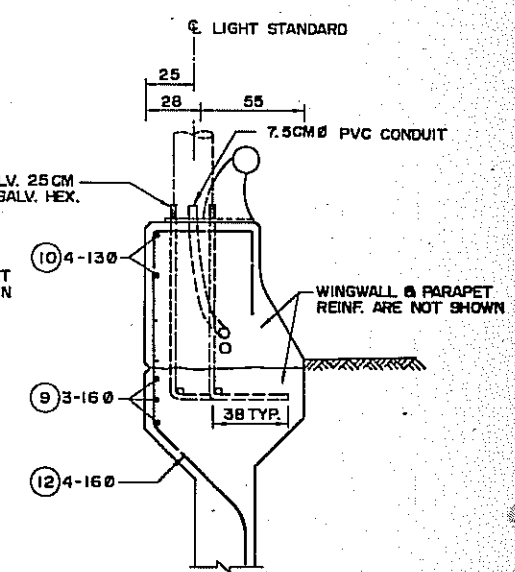
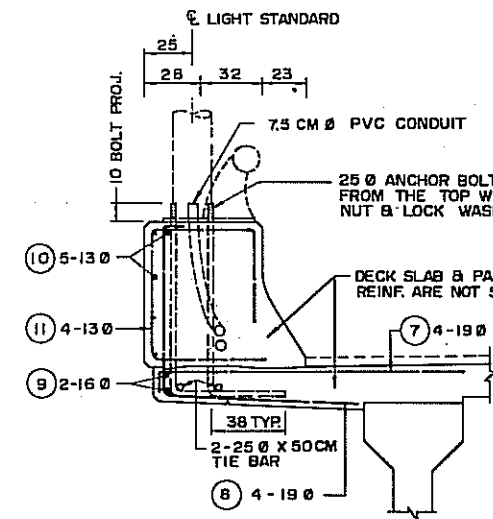
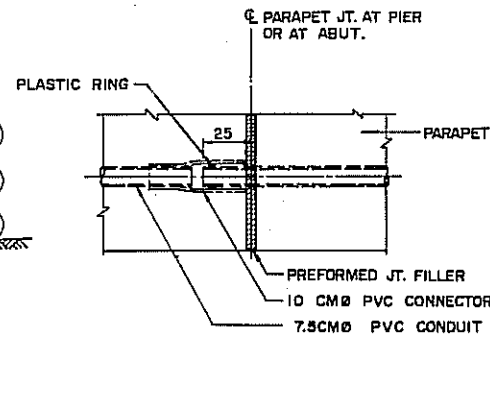
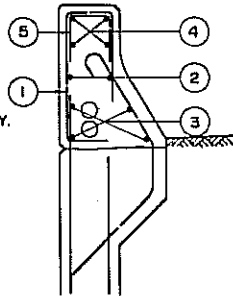
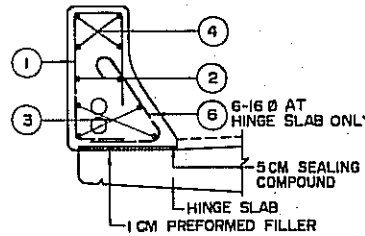
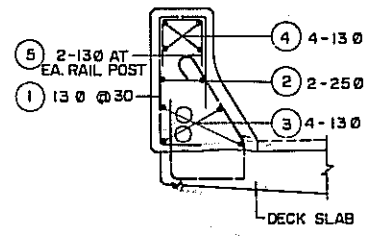
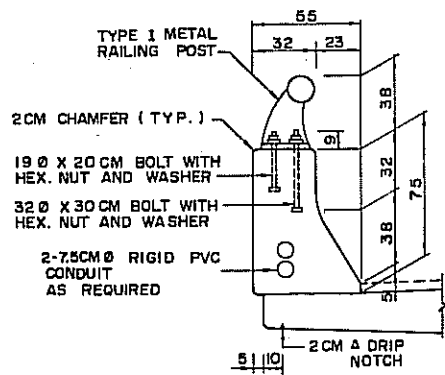
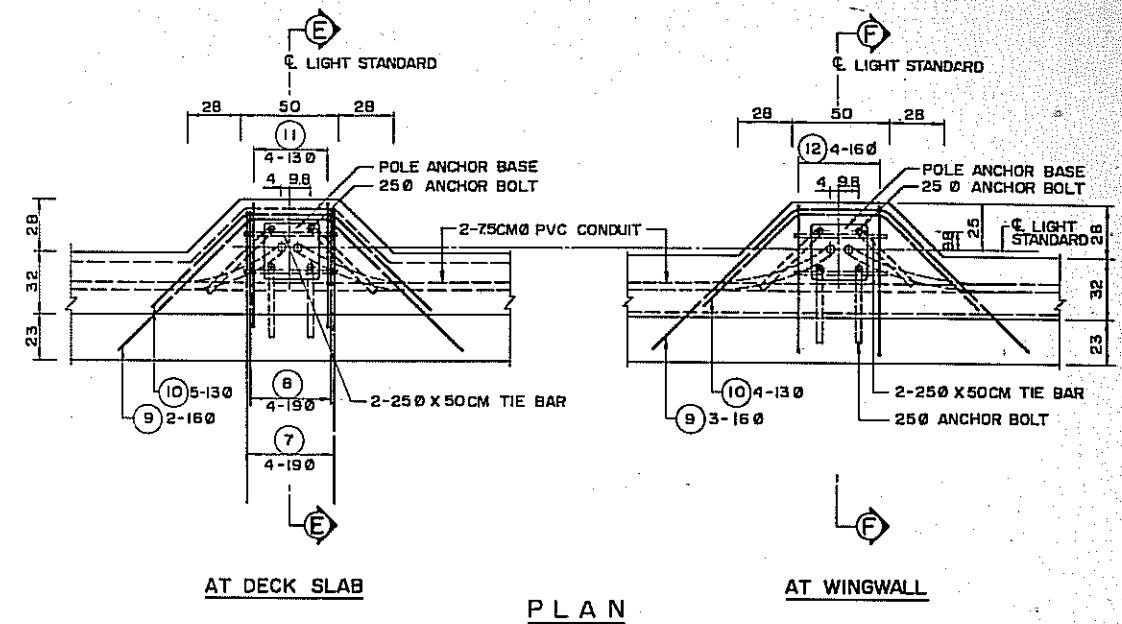
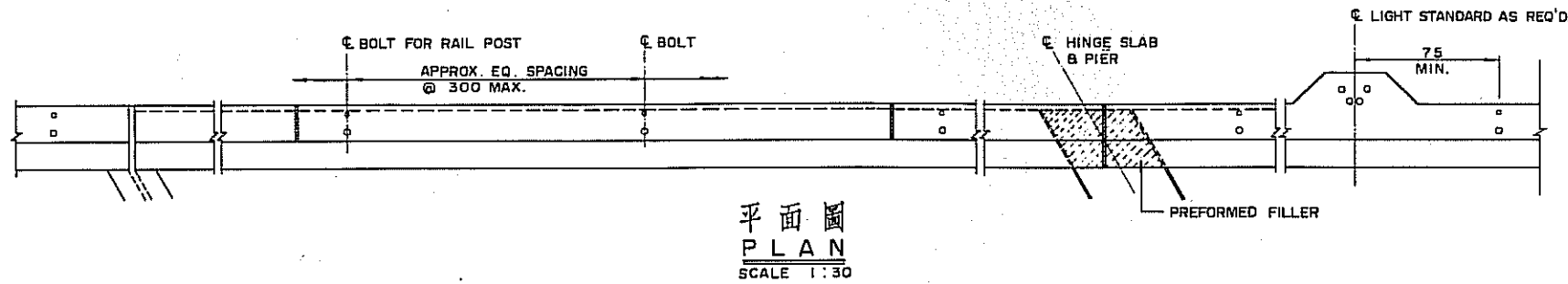
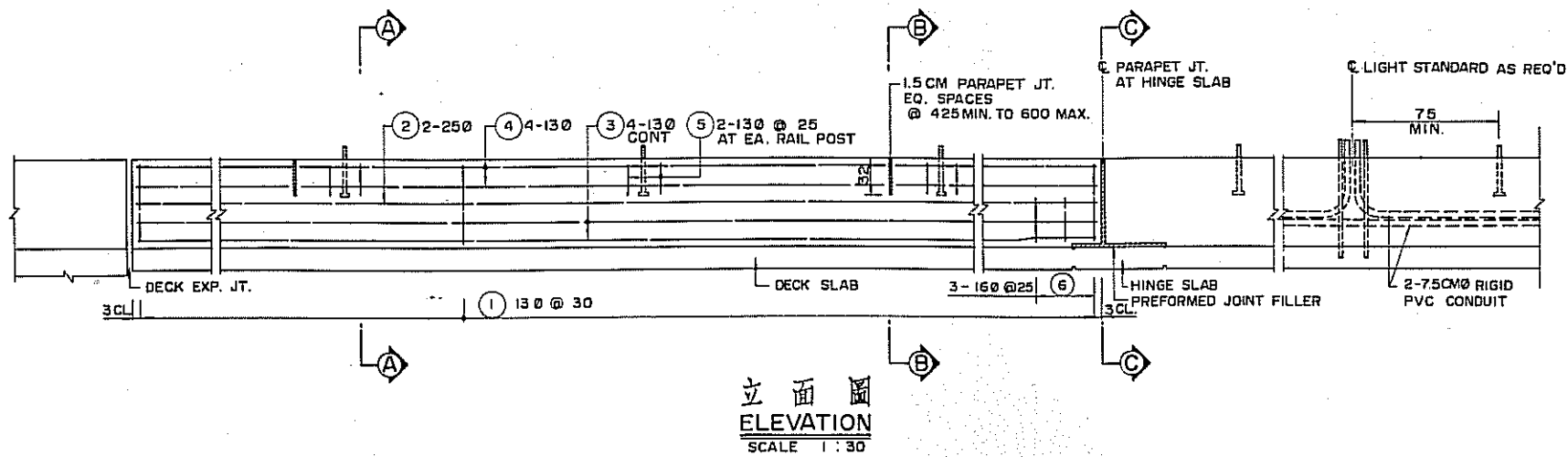

燈
柱
基
座
詳
圖
L
I
G
H
T
S
T
A
N
D
A
R
D
S
U
P
P
O
R
T
D
E
T
A
I
L
S
SCALE 1:20

斷
面
圖
A
-
A
S
E
C
T
I
O
N
A
-
A
SCALE 1:20

說
明:

1. 總說明參照圖 ST-1.
2. 燈柱基座位置參照圖照明設施.

NOTE:

1. FOR GENERAL NOTES SEE SHEET ST-1.
2. FOR LIGHT STANDARD LOCATION SEE LIGHTING PLAN.

鋼
筋
表
L
I
S
T
O
F
R
E
I
N
F
O
R
C
I
N
G
B
A
R
S

SHAPE	MARK	REMARK	SHAPE	MARK	REMARK
	①	130 @ 30		⑦	190
	②	250		⑧	190
	③	130		⑨	160
	④	130		⑩	130
	⑤	130		⑪	130
	⑥	160 @ 25		⑫	160

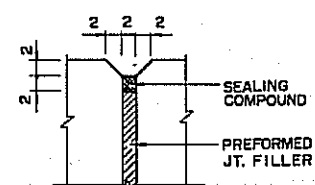
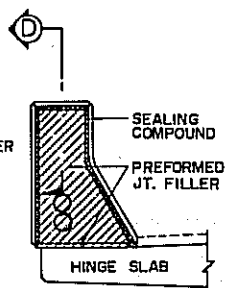
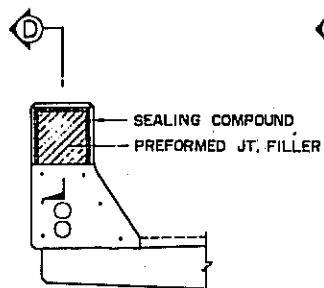

胸
牆
詳
圖
P
A
R
A
P
E
T
D
E
T
A
I
L
S

STD. DETAILS FOR U/C & CHANNEL BRIDGE

修正	REVISIONS	項目	ITEM	日期	DATE

交通部台灣區高速公路工程局
TAIWAN AREA FREEWAY CONSTRUCTION BUREAU
中華民國
REPUBLIC OF CHINA
南北高速公路
NORTH-SOUTH FREEWAY
苗栗台中段
MIAOLI-TAICHUNG SECTION
胸牆及燈柱基座詳圖
PARAPET & LIGHT
STANDARD SUPPORT DETAILS
中華顧問工程司
CHINA ENGINEERING CONSULTANTS, INC.
日期 DATE AUG. '74 比例 SCALE AS SHOWN 圖號 SHEET ST-3

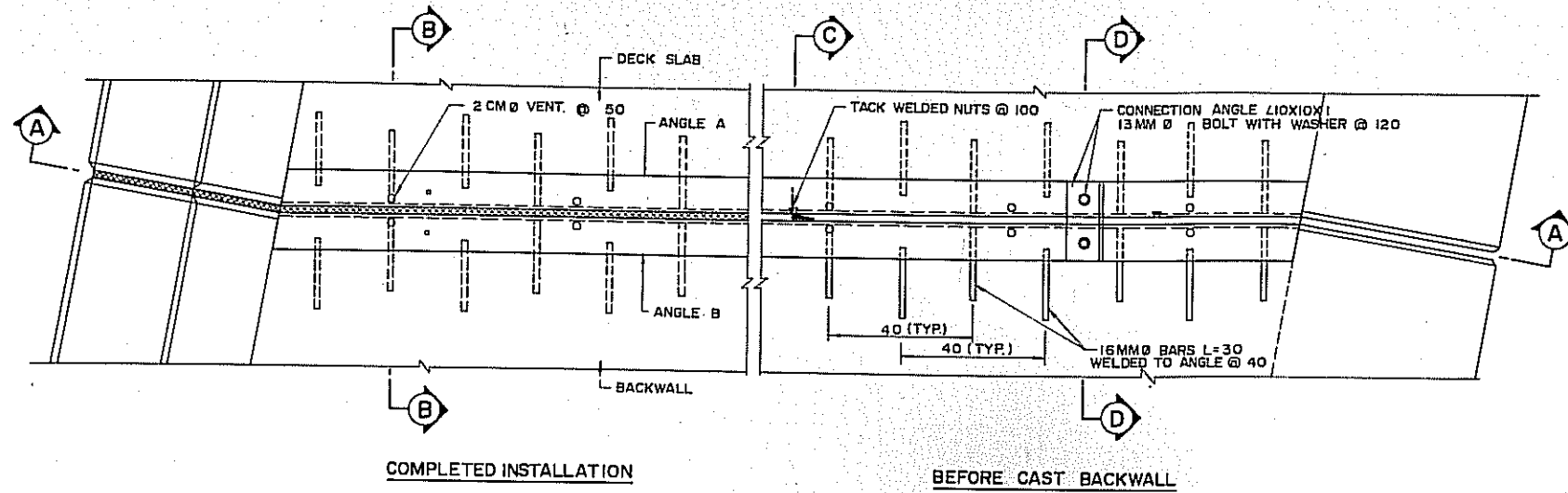

平面圖
PLAN
SCALE 1:16

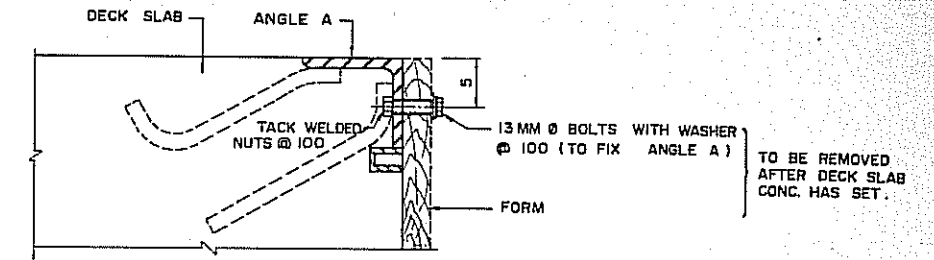

斷面圖 C—C
SECTION C—C
SCALE 1:4

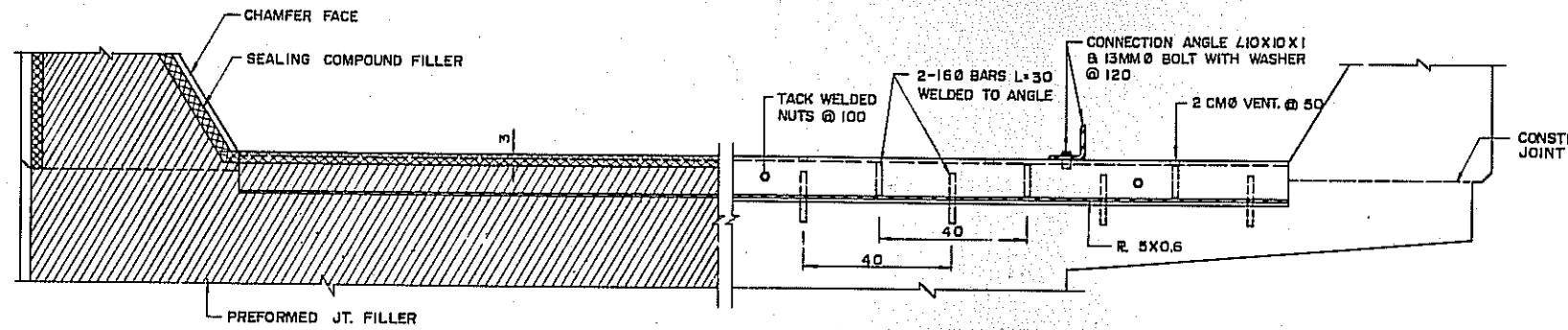

斷面圖 A—A
SECTION A—A
SCALE 1:10

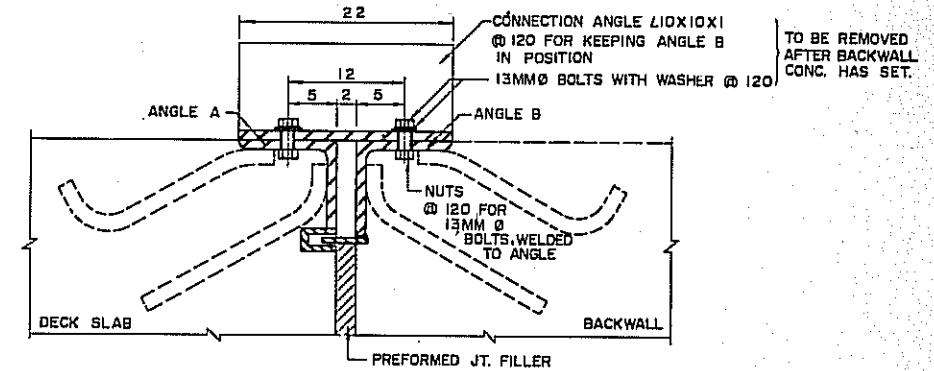

斷面圖 D—D
SECTION D—D
SCALE 1:4

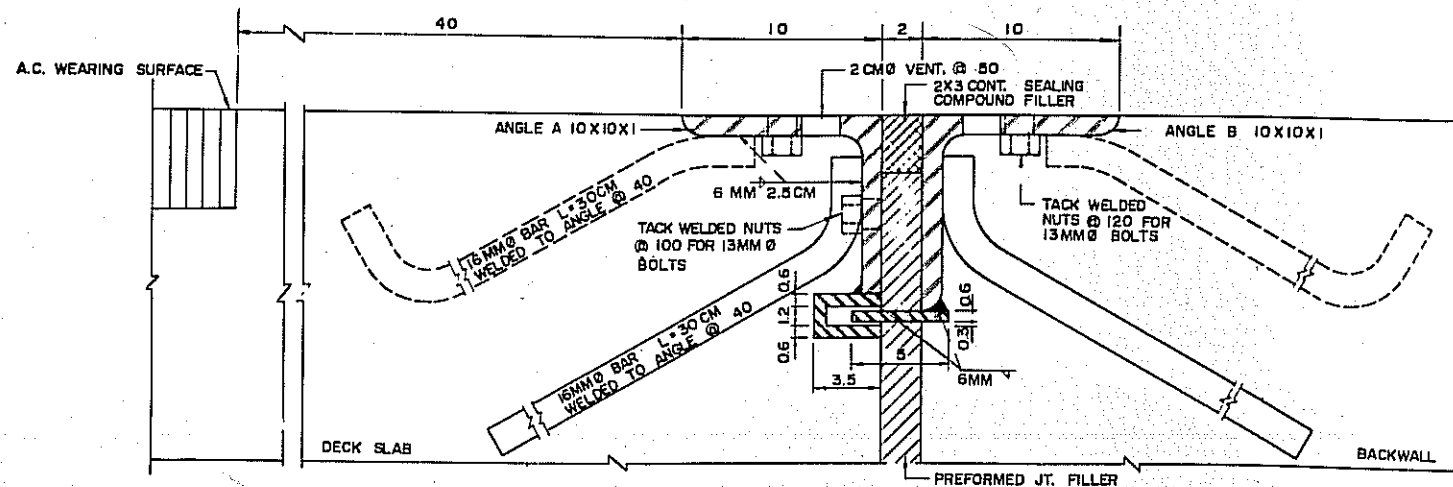

斷面圖 B—B
SECTION B—B
SCALE 1:2

說明:

1. 各項尺寸除另有註明者外，單位均以公分計。
2. 角鋼及鋼板須為軟鋼，並須符合 ASTM A-36 之規定或經核准之同級品。
3. 鋼料組件製成後，須經熱浸鍍鋅處理。
4. 焊接材料及方法須合於美國焊接學會出版之“公路及鐵路橋之焊接規範”。
5. 伸縮縫板頂必須與路面坡度一致。
6. 受工程司之允許 ±2.5 公分伸縮量之 WABOFLEX 或 TRANSFLEX 型可代替角鋼型。

NOTES:

1. ALL DIMENSIONS ARE IN CM UNLESS OTHERWISE NOTED.
2. ANGLE B PLATES SHALL BE MILD STEEL CONFORMING TO ASTM A-36 OR APPROVED EQUAL.
3. STEEL COMPONENTS SHALL BE HOT DIP GALVANIZED AFTER FABRICATION.
4. WELDING MATERIALS AND METHODS SHALL CONFORM TO AWS "SPECIFICATIONS FOR WELDED HIGHWAY AND RAILWAY BRIDGES."
5. THE TOP FACE OF EXP. JT. SHOULD COINCIDE WITH THE ROADWAY GRADE.
6. WITH THE PERMISSION OF ENGINEER, THE WABOFLEX TYPE OR TRANSFLEX TYPE HAVING 2.5 CM ELONGATION OR SHORTENING CAN BE USED INSTEAD OF ANGLE TYPE.

STD. DETAILS FOR U/C & CHANNEL BRIDGE

修正 項目	REVISIONS ITEM	日期 DATE

交通部台灣區高速公路工程局
TAIWAN AREA FREEWAY CONSTRUCTION BUREAU
中華民國
REPUBLIC OF CHINA
南北高速公路
MIAOLI-TAICHUNG SECTION
苗栗台中段
橋面伸縮縫詳圖
DECK EXPANSION
JOINT DETAILS
中華顧問工程司
CHINA ENGINEERING CONSULTANTS, INC.
日期 DATE AUG. '74 比例 SCALE AS SHOWN 圖號 SHEET ST-4

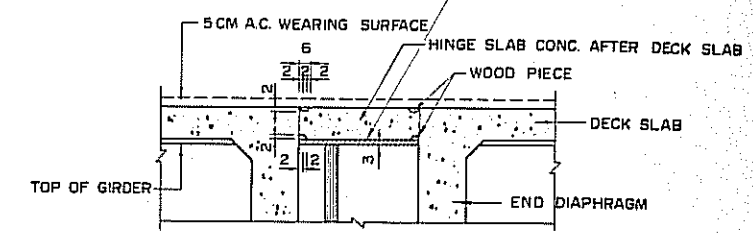
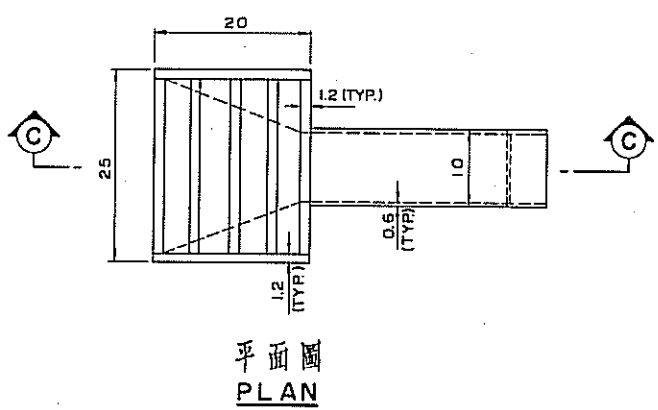
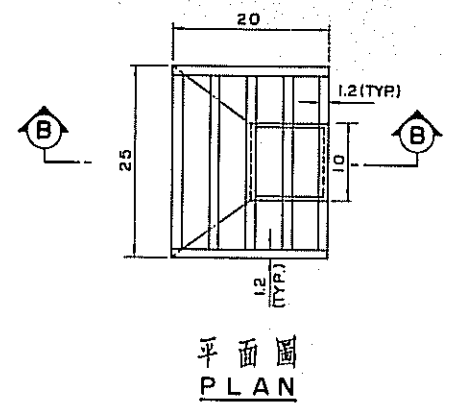
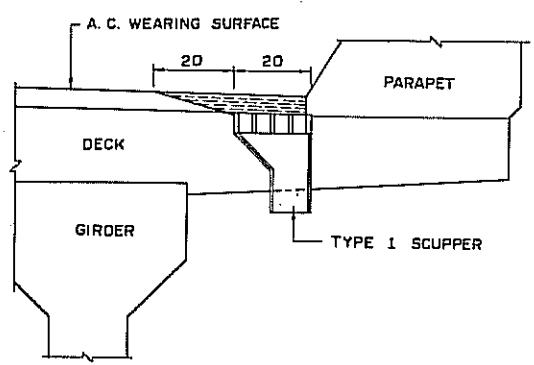
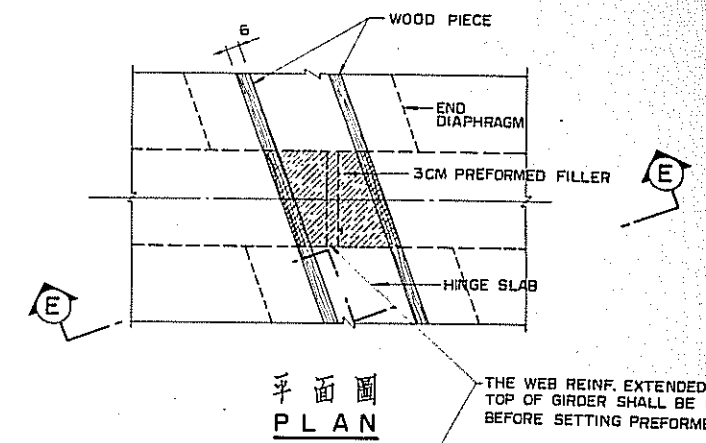
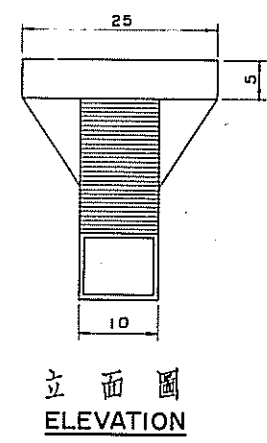
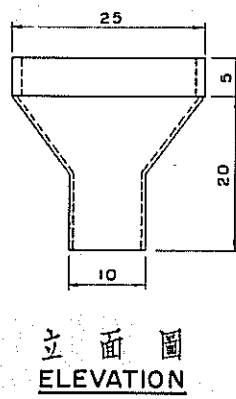
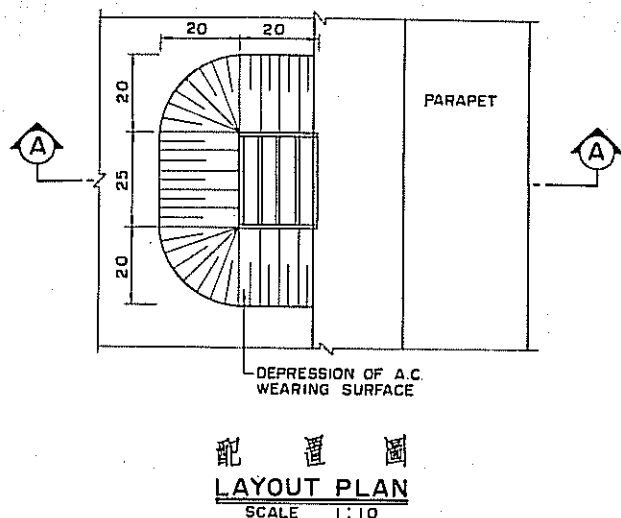

鉸接版詳圖
HINGE SLAB DETAIL
SCALE 1:20

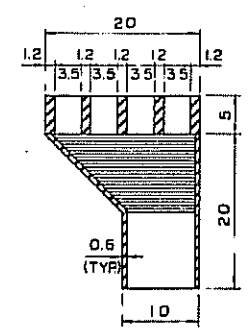
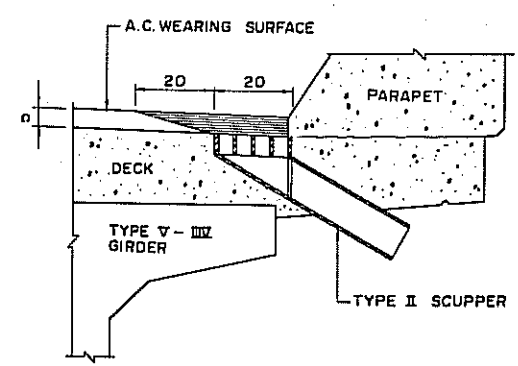

型式 I 洩水孔
TYPE I SCUPPER
SCALE 1:5

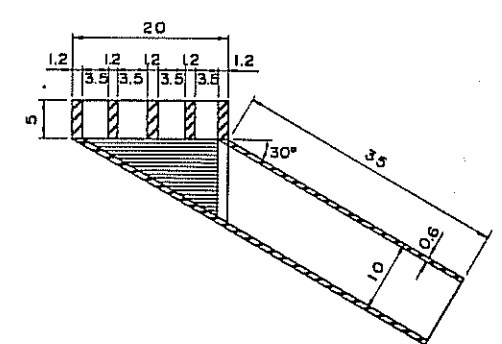

型式 II 洩水孔
TYPE II SCUPPER
SCALE 1:5

斷面圖 A-A
SECTION A-A
SCALE 1:10

洩水孔詳圖
SCUPPER DETAIL
(FOR CHANNEL BRIDGE)

說明:

1. 總說明參照圖 ST-1.
2. 洩水孔須用鑄鋼或焊接鋼板製成.
3. 焊接材料及方法須符合美國焊接學會規範.
4. 洩水孔製成後須經熱浸鍍鋅處理.

NOTES:

1. FOR GENERAL NOTES SEE SHEET ST-1.
2. SCUPPERS SHALL BE MADE OF CAST STEEL OR WELDED STEEL PLATES.
3. WELDING MATERIALS AND METHOD SHALL CONFORM TO AWS SPECIFICATIONS.
4. SCUPPER SHALL BE HOT DIP GALVANIZED AFTER FABRICATION.

REVISIONS		STD. DETAILS FOR U/C & CHANNEL BRIDGE	
修正	REVISIONS	項目	日期 DATE
		交通部台灣區高速公路工程局	
		TAIWAN AREA FREEWAY CONSTRUCTION BUREAU	
		中華民國	
		REPUBLIC OF CHINA	
		南北高速公路	
		NORTH-SOUTH FREEWAY	
		苗栗台中段	
		MIAOLI-TAICHUNG SECTION	
		洩水孔及鉸接版詳圖	
		SCUPPERS & HINGE SLAB DETAILS	
		中華顧問工程司	
		CHINA ENGINEERING CONSULTANTS, I	
		日期 DATE AUG. '74	比例 SCALE AS SHOWN
		圖號 SHEET	ST-5

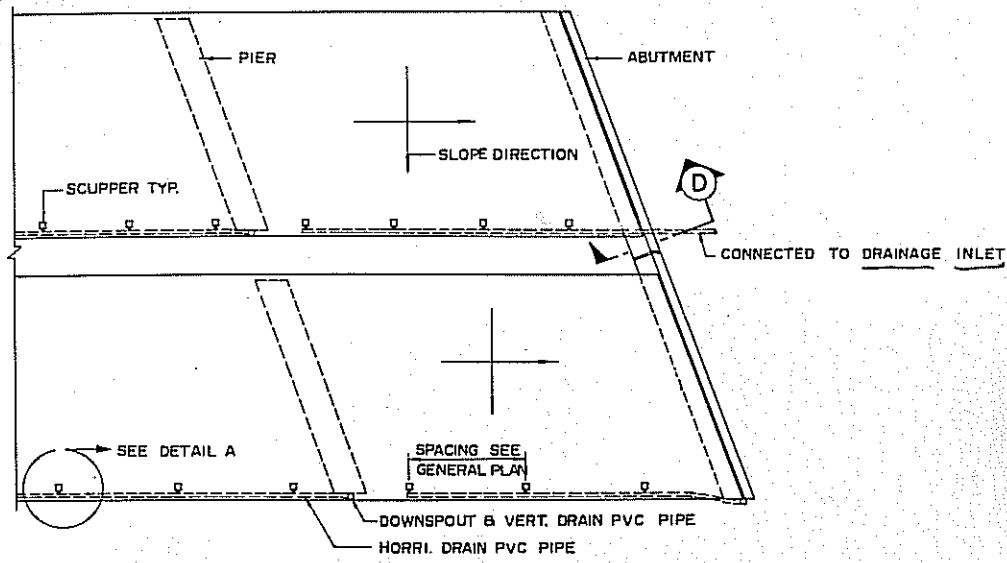

平面圖
PLAN

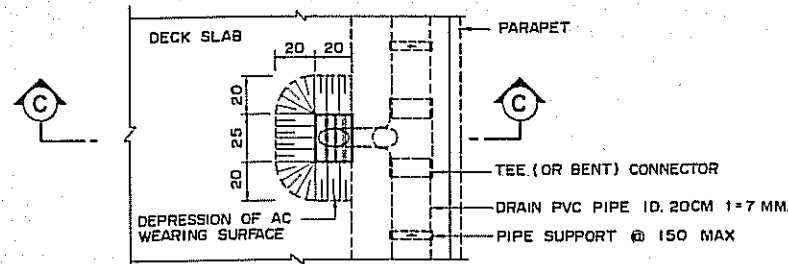

平面圖
PLAN

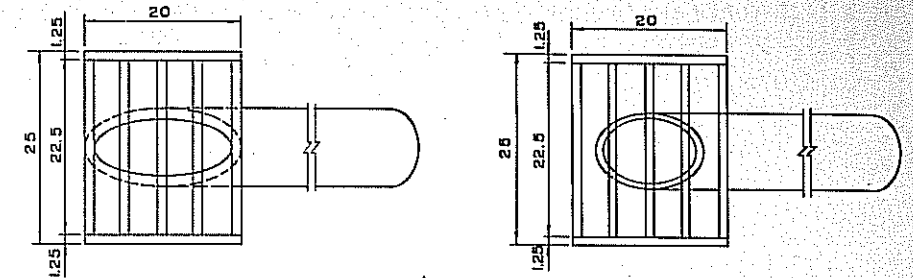

平面圖
PLAN

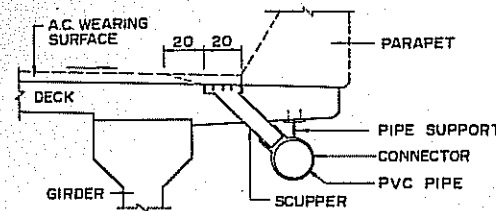

(FOR TYPE III, IV GIRDER)

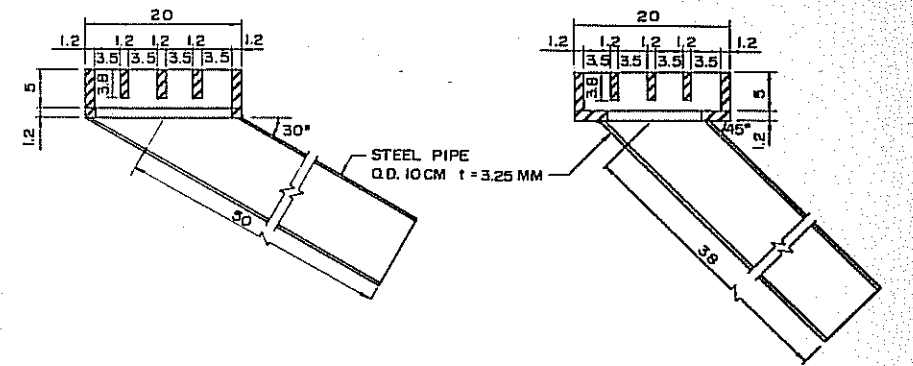

(FOR TYPE V-VIII GIRDER) 斷面圖 SECTION (FOR TYPE III, IV GIRDER)

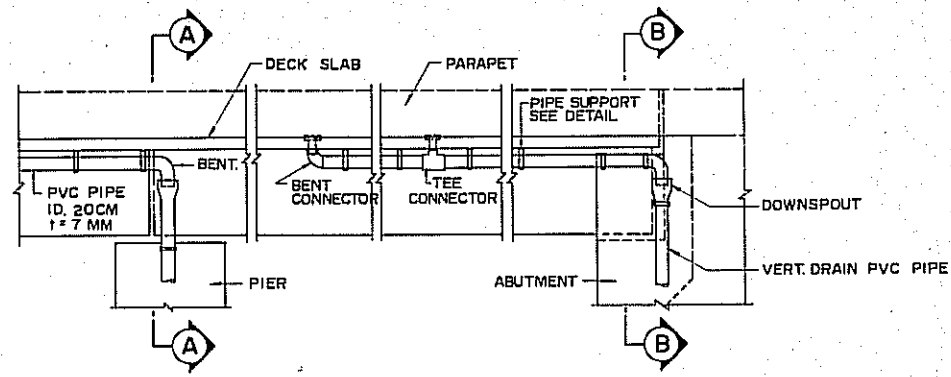

ELEVATION

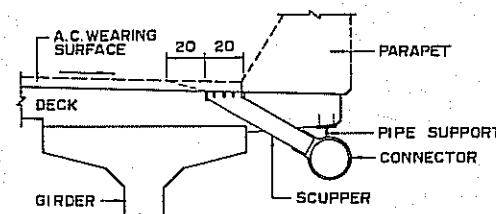

(FOR TYPE V-VIII GIRDER)

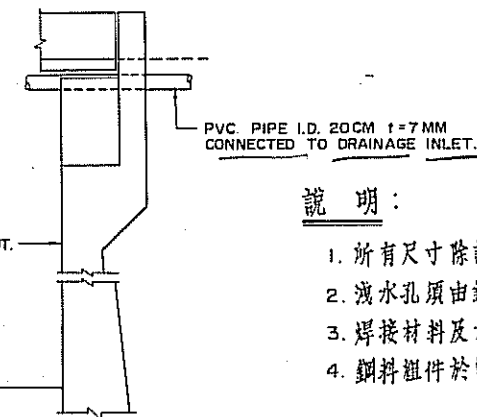

澆水孔詳圖
SCUPPER DETAIL
SCALE 1:5

斷面圖 C-C
SECTION C-C

斷面圖 D-D
SECTION D-D
N.T.S.

說明:

1. 所有尺寸除註明者外均以公分計。
2. 澆水孔須由鑄鋼或焊接鋼板製成。
3. 焊接材料及方法須符合美國焊接學會規範。
4. 鋼料組件於製成後，須經熱浸鍍鋅處理。

NOTES:

1. ALL DIMENSIONS ARE IN CM UNLESS OTHERWISE NOTED.
2. SCUPPERS SHALL BE MADE OF CAST STEEL OR WELDED STEEL PLATES.
3. WELDING MATERIALS AND METHODS SHALL CONFORM TO A.W.S. "SPECIFICATIONS FOR WELDED HIGHWAY AND RAILWAY BRIDGES"
4. STEEL COMPONENTS SHALL BE HOT DIP GALVANIZED AFTER FABRICATION.

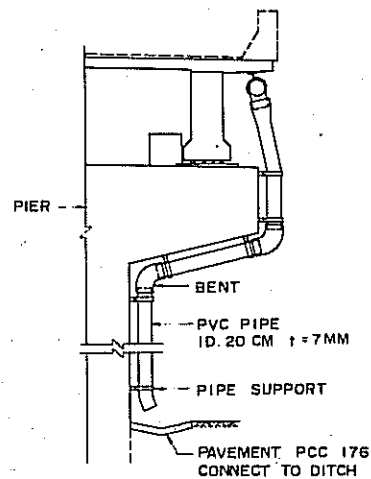

斷面圖 A-A
SECTION A-A

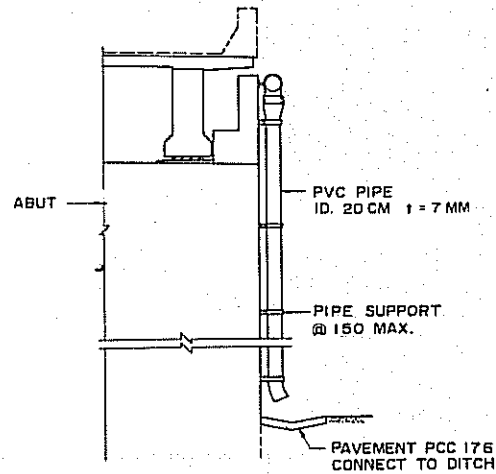

斷面圖 B-B
SECTION B-B

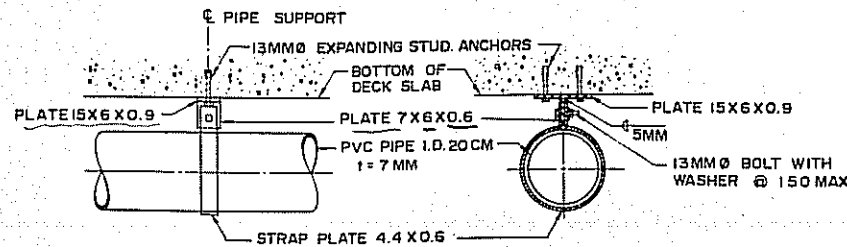

正視圖
FRONT VIEW

斷面圖
SECTION

圓管支承詳圖
PIPE SUPPORT DETAILS
SCALE 1:10

澆水孔及落水管位置圖
LOCATION OF SCUPPER & DOWNPIPE
N.T.S.

STD. DETAILS FOR U/C & CHANNEL BRIDGE

修正 REVISIONS	項目 ITEM	日期 DATE	交通部台灣區高速公路工程局 TAIWAN AREA FREEWAY CONSTRUCTION BUREAU	中華民國 REPUBLIC OF CHINA
			南北高速公路 苗粟台中段	NORTH-SOUTH FREEWAY MIAOLI-TAICHUNG SECTION
			澆水孔及落水管詳圖	SCUPPER & DOWNPIPE DETAILS
			中華顧問工程司 CHINA ENGINEERING CONSULTANTS	中華顧問工程司 CHINA ENGINEERING CONSULTANTS
			日期 DATE AUG. '74	比例 SCALE AS SHOWN
				圖號 SHEET ST-6

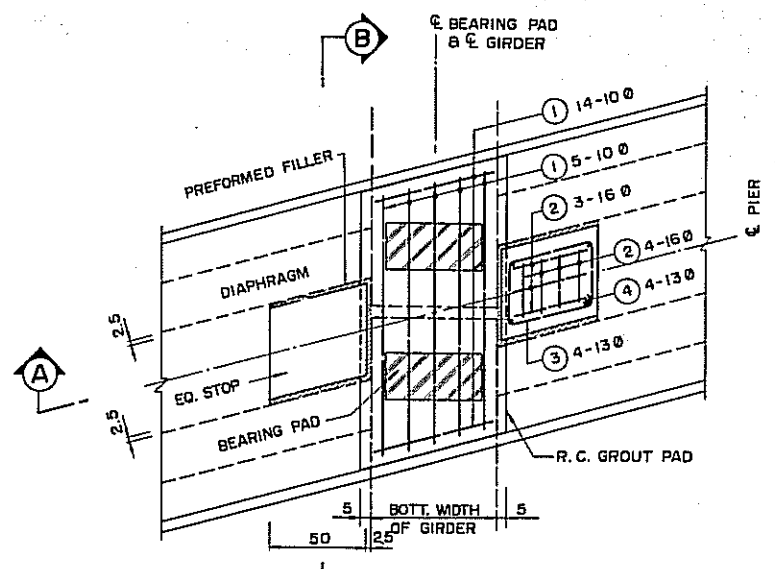

橋墩上之平面
PLAN-ON PIER

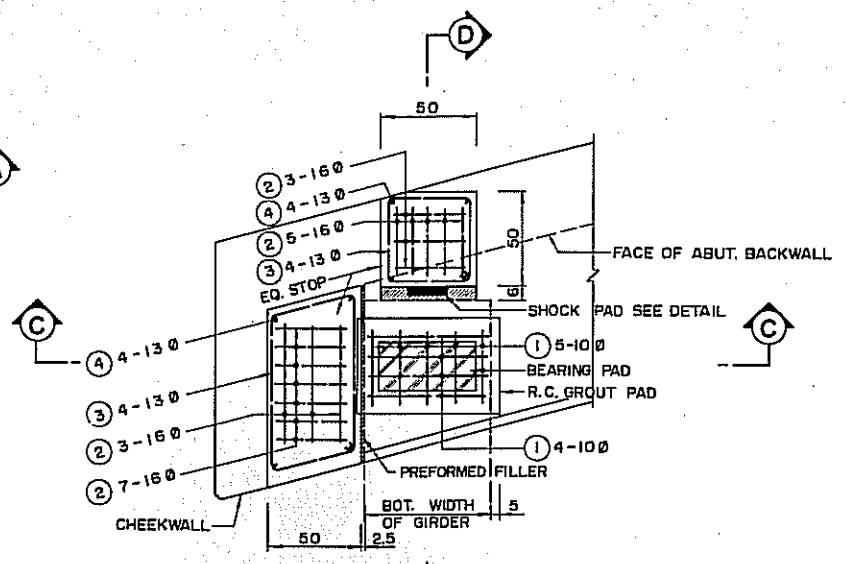

橋台上之平面
PLAN-ON ABUTMENT

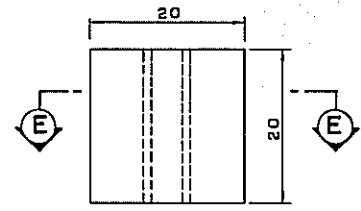

正視圖
FRONT VIEW

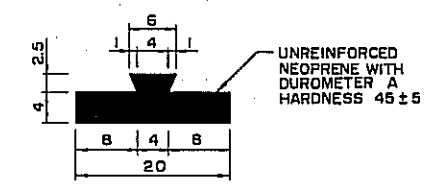

斷面圖 E-E
SECTION E-E

防震版詳圖
SHOCK PAD DETAIL
SCALE 1:6

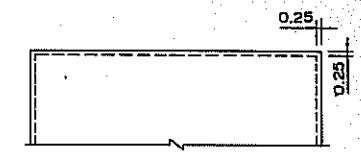

平面圖
PLAN

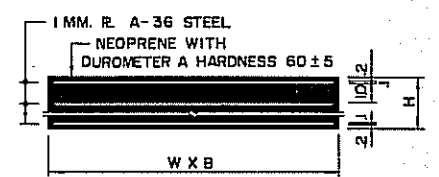

斷面圖
SECTION

支承版詳圖
BEARING PAD DETAIL
SCALE 1:2

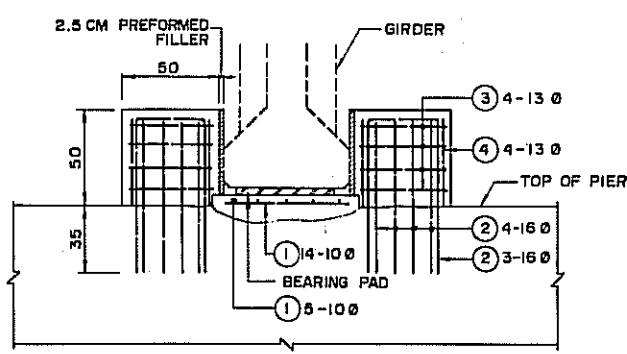

斷面圖 A-A
SECTION A-A

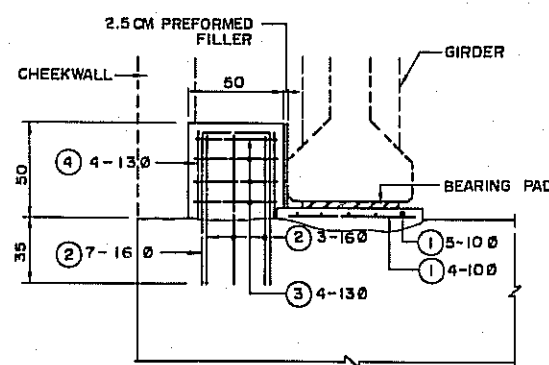

斷面圖 C-C
SECTION C-C

鋼筋表
LIST OF REINFORCING STEELS

SHAPE	NOMINAL DIA. (MM)	REMARK
①	10Ø	
②	16Ø	
③	13Ø	
④	13Ø	

支承版尺寸表
LIST OF DIMENSION FOR BEARING PAD

TYPE	GIRDER		W (CM)	B (CM)	H (CM)	REMARK
	TYPE	LENGTH (M)				
A	III-IV	6-10	40	15	3.8	$H=0.2+Q_1+1.0+Q_1+1.0+0.1+1.0+0.1+0.2=3.8$
B	III	17-19	45	20	2.7	$H=0.2+Q_1+1.0+Q_1+1.0+0.1+0.2=2.7$
C	IV	20-22	45	20	3.8	$H=0.2+Q_1+1.0+Q_1+1.0+Q_1+1.0+Q_1+0.2=3.8$
D	IV	23-25	50	20	3.8	"
E	V-VII	30-35	65	25	3.8	"
F	VIII	20	55	22	4.9	$H=0.2+Q_1+1.0+Q_1+1.0+Q_1+1.0+Q_1+1.0+Q_1+0.2=4.9$
G	VIII	40	65	30	4.9	"

說明:

1. 應說明參照圖 ST-1。
2. 混凝土墊必須水平，表面平整，安裝支承版必須與混凝土面完全接觸。
3. 止震塊與混凝土墊須依照橋樑之交角調整之。

NOTES:

1. FOR GENERAL NOTES SEE SHEET ST-1.
2. R.C. GROUT PAD SHOULD HAVE A HORIZONTAL AND SMOOTH FACE. BEARING PAD SHOULD BE PLACED PERFECTLY IN CONTACT WITH THE CONCRETE FACE.
3. FOR EQ. STOP & R.C. GROUT PAD SHALL BE ADJUSTED ACCORDING TO THE CROSSING ANGLE α OF THE BRIDGE.

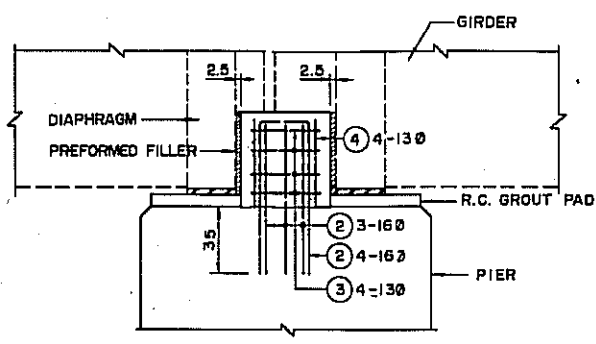

斷面圖 B-B
SECTION B-B

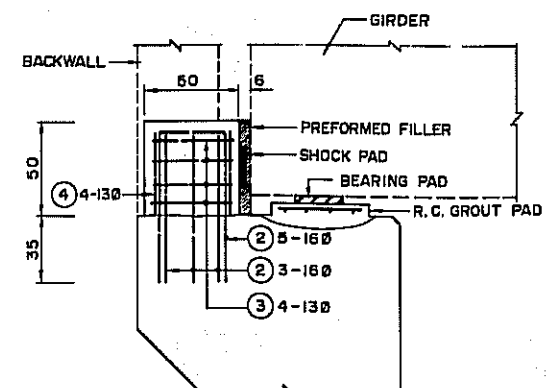

斷面圖 D-D
SECTION D-D

止震塊及混凝土墊詳圖
EQ. STOP & R.C. GROUT PAD DETAIL
SCALE 1:20

STD. DETAILS FOR U/C & CHANNEL BRIDGE

修正	REVISIONS	項目	ITEM	日期	DATE

交通部台灣區高速公路工程局
TAIWAN AREA FREEWAY CONSTRUCTION BUREAU
中華民國
REPUBLIC OF CHINA
南北高速公路
NORTH-SOUTH FREEWAY
苗栗台中段
MIAOLI-TAICHUNG SECTION
止震塊、混凝土墊
EQ. STOP, R.C. GROUT PAD
及支承版詳圖
& BEARING PAD DETAILS
中華顧問工程司
CHINA ENGINEERING CONSULTANTS, INC.
日期 DATE AUG. '74 比例 SCALE AS SHOWN 圖號 SHEET ST-7

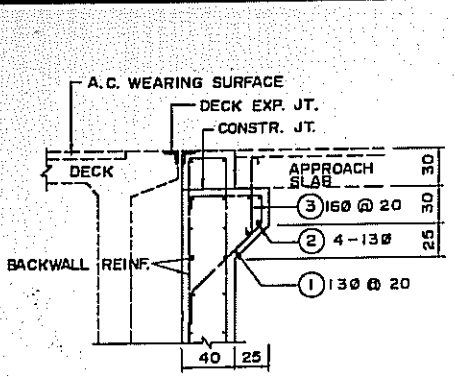

背牆頂部詳圖
DETAIL OF BACKWALL TOP
SCALE 1:30

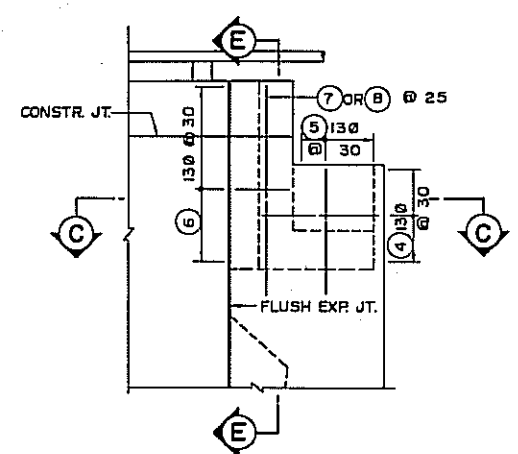

立面圖 (I)
ELEVATION (I)

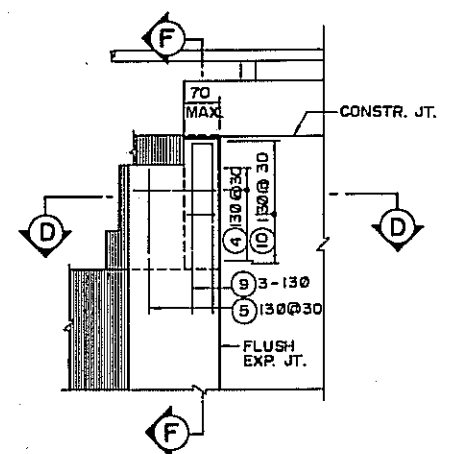

立面圖 (II)
ELEVATION (II)

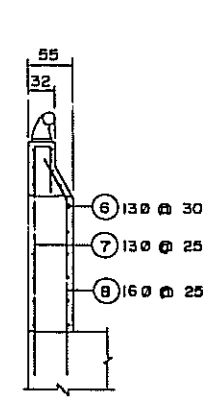

斷面圖 E—E
SECTION E—E

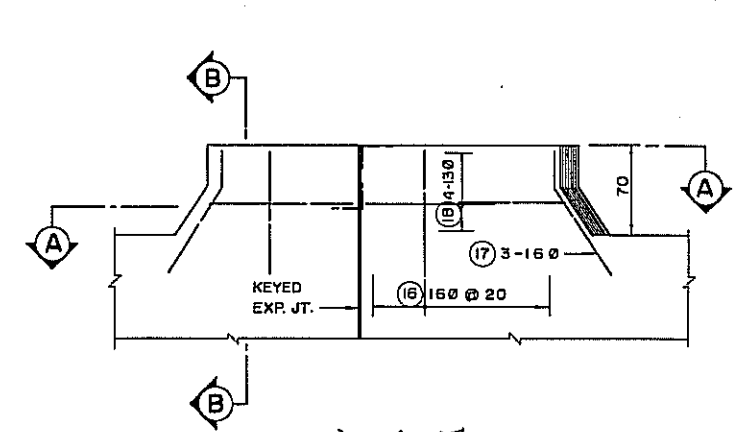

立面圖
ELEVATION

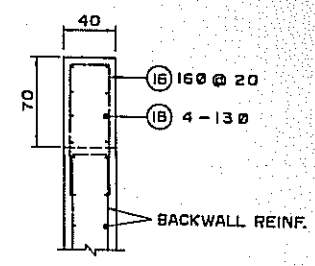

斷面圖 B—B
SECTION B—B

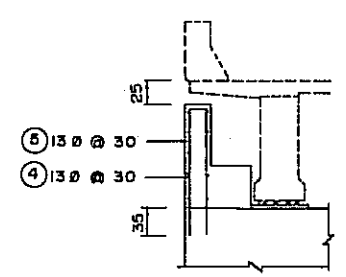

斷面圖 G—G
SECTION G—G

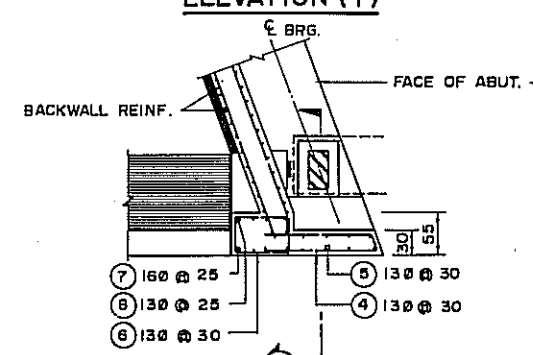

斷面圖 C—C
SECTION C—C

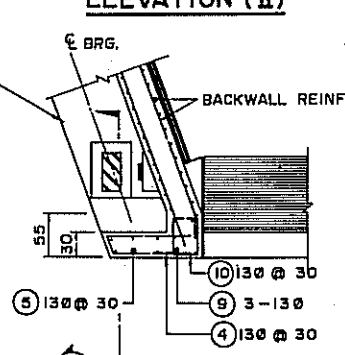

斷面圖 D—D
SECTION D—D

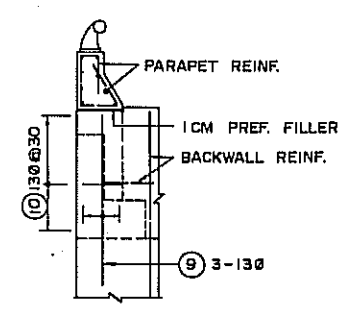

斷面圖 F—F
SECTION F—F

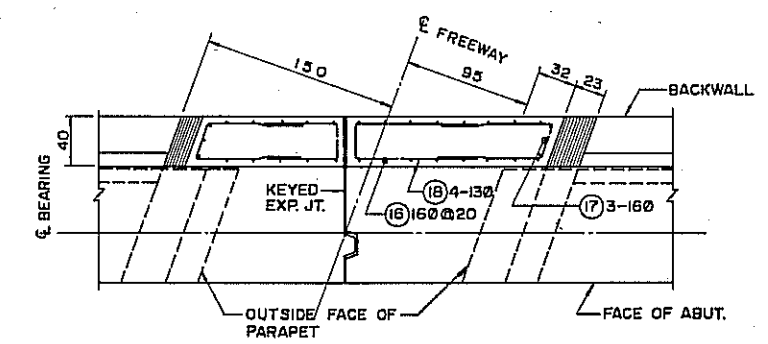

斷面圖 A—A
SECTION A—A

中間高背牆詳圖
DETAIL OF MEDIAN BACKWALL
SCALE 1:30

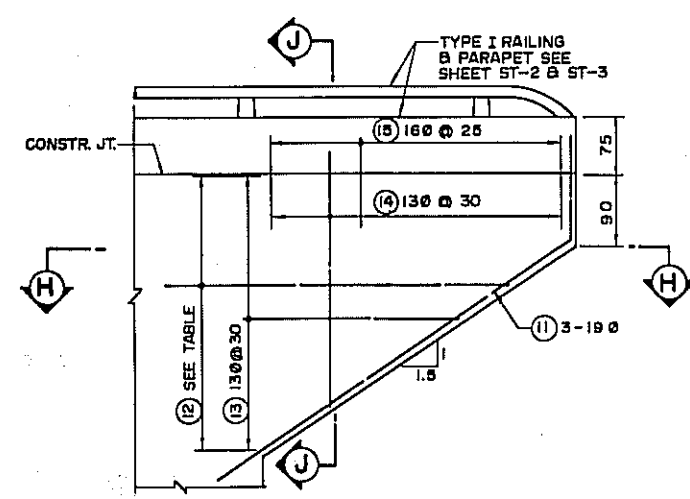

立面圖
ELEVATION

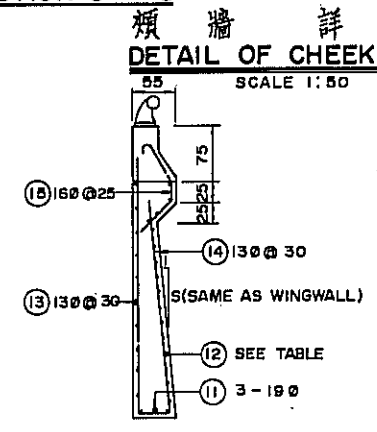

斷面圖 J—J
SECTION J—J

L	2 M	3 M	4 M
(12)	160 @ 20	190 @ 20	220 @ 20

表
TABLE

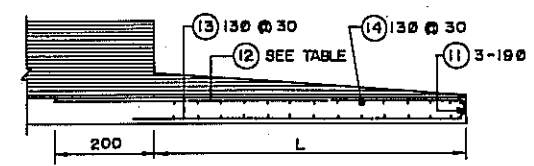

斷面圖 H—H
SECTION H—H

翼牆耳詳圖
DETAIL OF WINGWALL EAR
SCALE 1:50

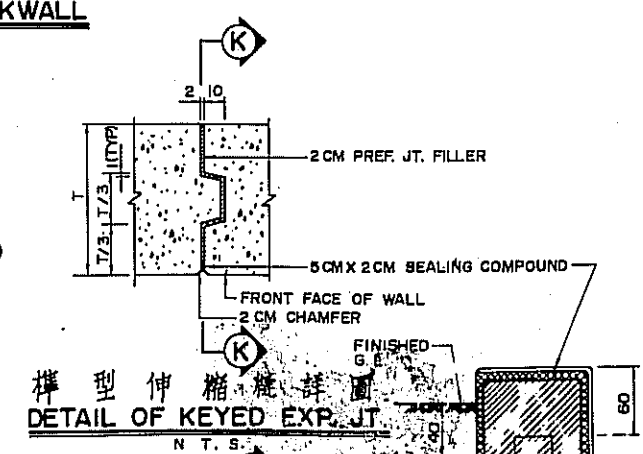

樅型伸縮縫詳圖
DETAIL OF KEYED EXP. JT.
N. T. S.

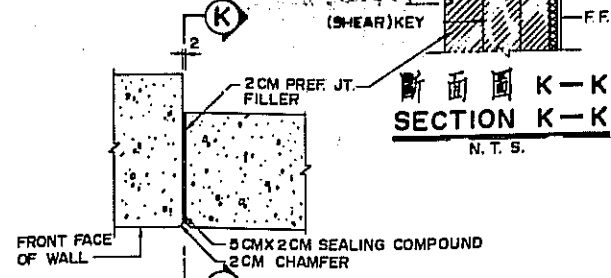

平型伸縮縫詳圖
DETAIL OF FLUSH EXP. JT.
N. T. S.

鋼筋表
LIST OF REINFORCING STEELS

SHAPE	NOMINAL DIA.(MM.)	REMARK
(1)	130	@ 20
(2)	130	
(3)	160	@ 20
(4)	130	@ 30
(5)	130	@ 30
(6)	130	@ 30
(7)	130	@ 25
(8)	160	@ 25
(9)	130	
(10)	130	@ 30
(11)	190	
(12)		SEE TABLE
(13)	130	@ 30
(14)	130	@ 30
(15)	160	@ 25
(16)	160	@ 20
(17)	160	
(18)	130	

說明：
總說明參照圖 ST-1.

NOTE:
FOR GENERAL NOTES SEE SHEET ST-1.

STD. DETAILS FOR U/C & CHANNEL BRIDGE

修正	REVISIONS	項目	ITEM	日期	DATE

交通部台灣區高速公路工程局
TAIWAN AREA FREEWAY CONSTRUCTION BUREAU
中華民國
REPUBLIC OF CHINA
南北高速公路 NORTH-SOUTH FREEWAY
苗栗台中段 MIAOLI-TAICHUNG SECTION
橋台詳細圖 (I) ABUTMENT DETAILS (I)
中華顧問工程司 CHINA ENGINEERING CONSULTANTS, INC.
日期 DATE AUG. 74 比例 SCALE AS SHOWN 圖號 SHEET ST-B

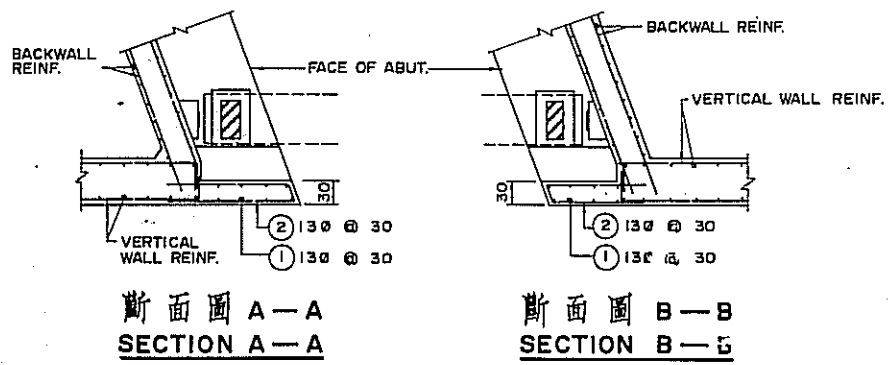
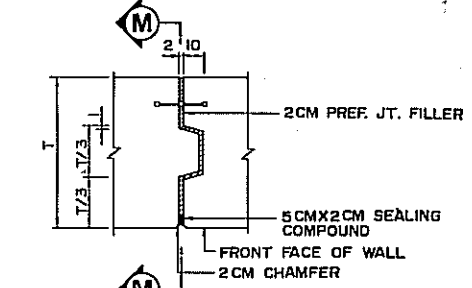
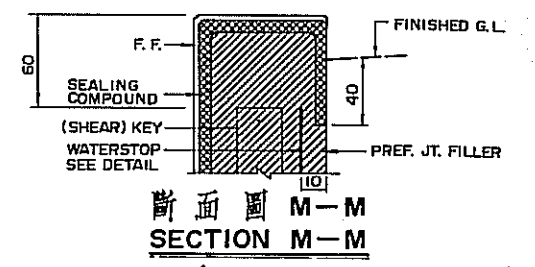
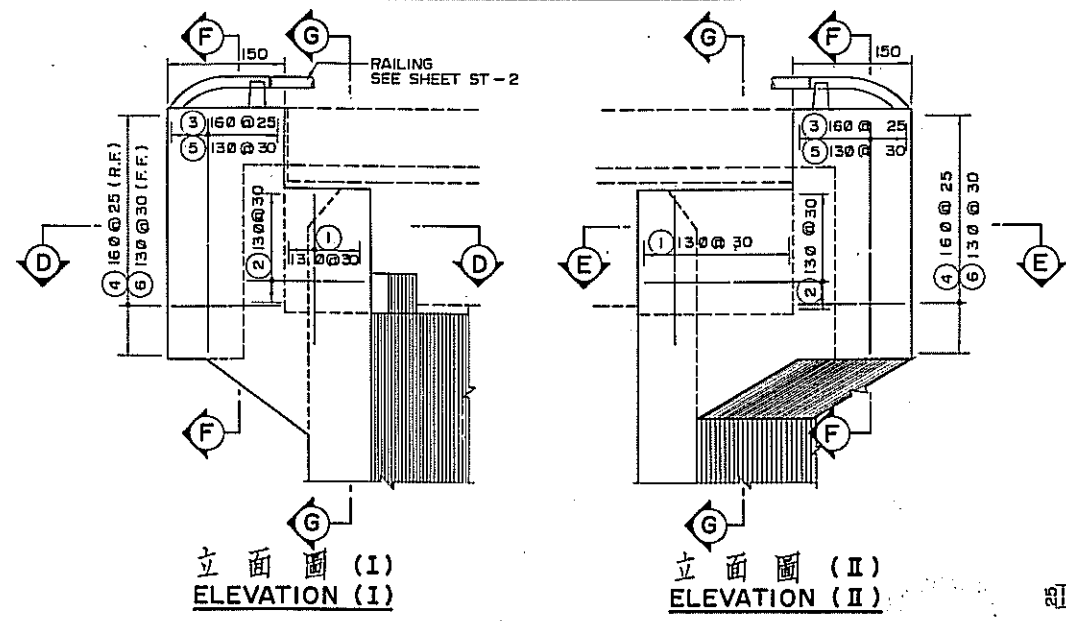
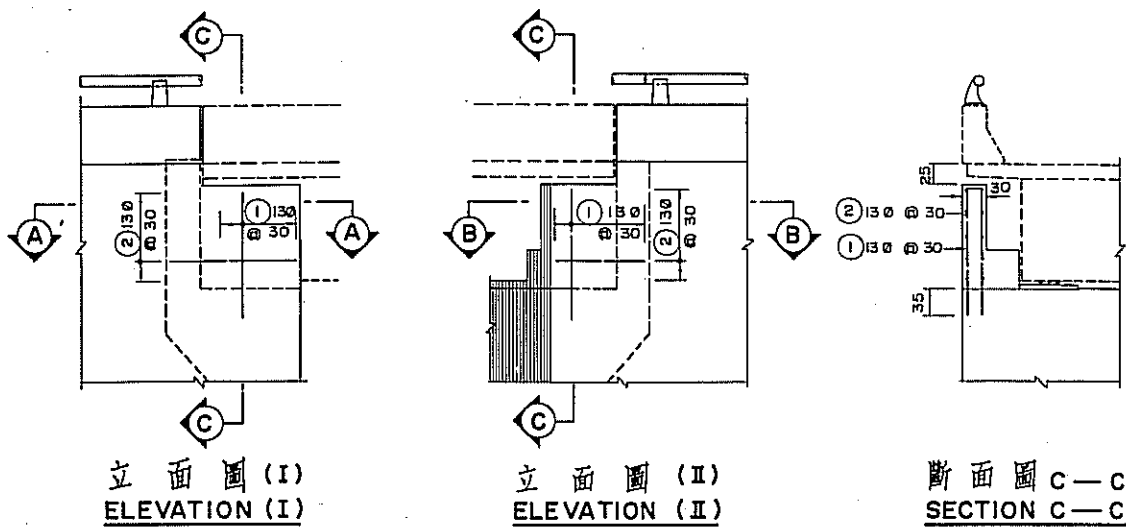

頰牆詳圖
DETAIL OF CHEEKWALL
SCALE 1:50

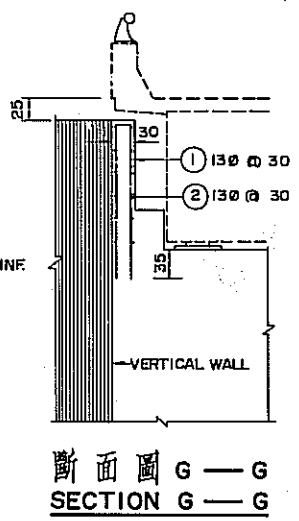
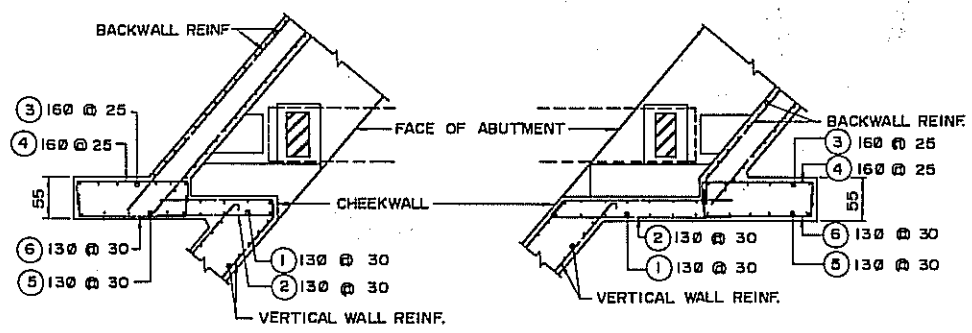

榫型伸縮縫詳圖
DETAIL OF KEYPED EXP. JT.

平型伸縮縫詳圖
DETAIL OF FLUSH EXP. JT.

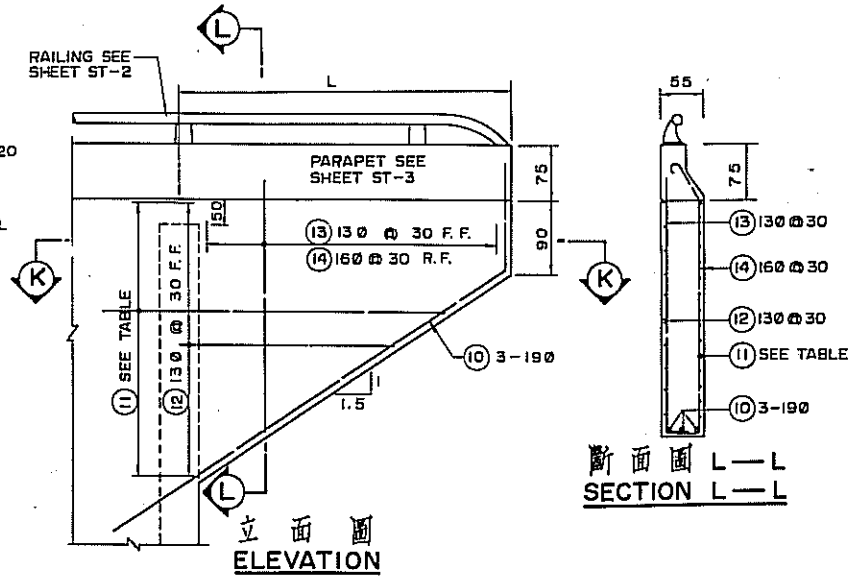
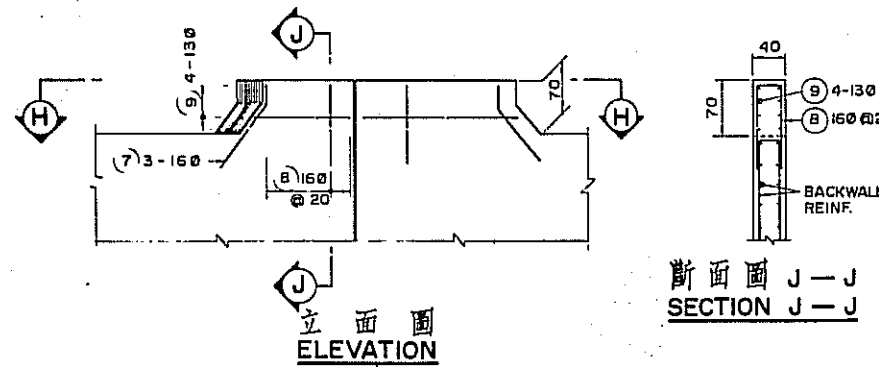

TABLE

L	(11)
300	190 @ 20
400	220 @ 20
500	250 @ 20
600	290 @ 20

斷面圖 K—K
SECTION K—K

翼牆耳詳圖
DETAIL OF WINGWALL EAR
SCALE 1:50

詳圖 B
DETAIL B
SCALE 1:50

鋼筋表
LIST OF REINFORCING STEELS

SHAPE	NOMINAL DIA.(MM.)	REMARK
①	130	@ 30
②	130	@ 30
③	160	@ 25
④	160	@ 25
⑤	130	@ 30
⑥	130	@ 30
⑦	160	
⑧	160	@ 20
⑨	130	
⑩	190	
⑪		SEE TABLE
⑫	130	@ 30
⑬	130	@ 30
⑭	160	@ 30

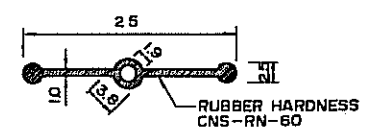

說明：
總說明參照圖 ST-1。

NOTE:
FOR GENERAL NOTES SEE SHEET ST-1.

STD. DETAILS FOR U/C & CHANNEL BRIDGE

修正 項目	REVISIONS ITEM	日期 DATE

交通部台灣區高速公路工程局
TAIWAN AREA FREEWAY CONSTRUCTION BUREAU
中華民國
REPUBLIC OF CHINA
南北高速公路
NORTH-SOUTH FREEWAY
苗栗台中段
MIAOLI-TAICHUNG SECTION
橋台詳圖(II) ABUTMENT DETAILS (II)
中華顧問工程司
CHINA ENGINEERING CONSULTANTS, INC.
日期 DATE AUG. '74 比例 SCALE AS SHOWN 圖號 SHEET ST-9

中間島背牆詳圖
DETAIL OF MEDIAN BACKWALL

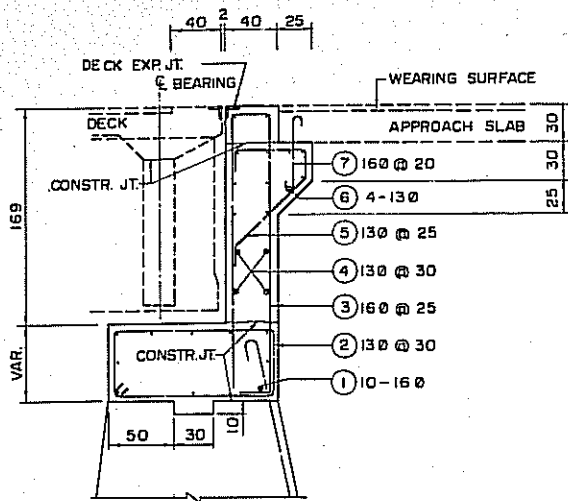

詳圖 A
DETAIL A
SCALE 1:30

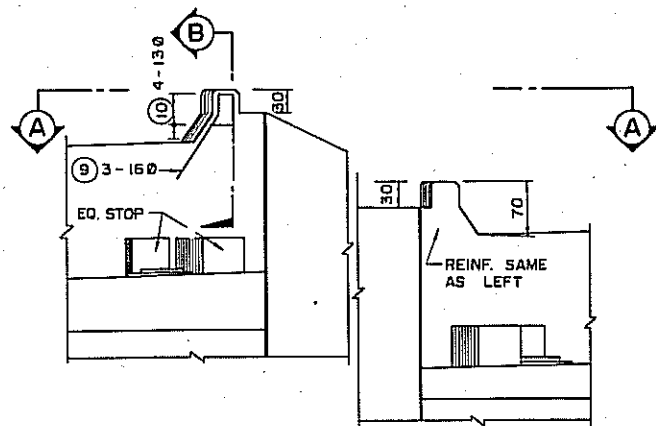

立面圖
ELEVATION
SCALE 1:50

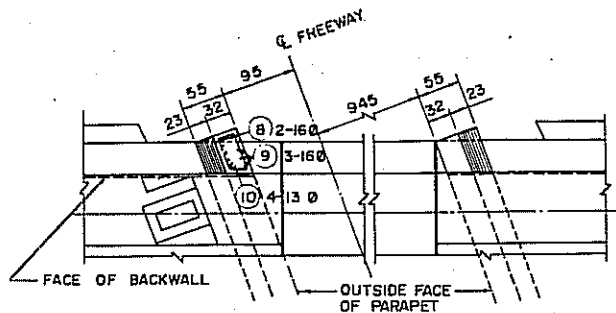

斷面圖 A—A
SECTION A—A
SCALE 1:50

詳圖 B
DETAIL B

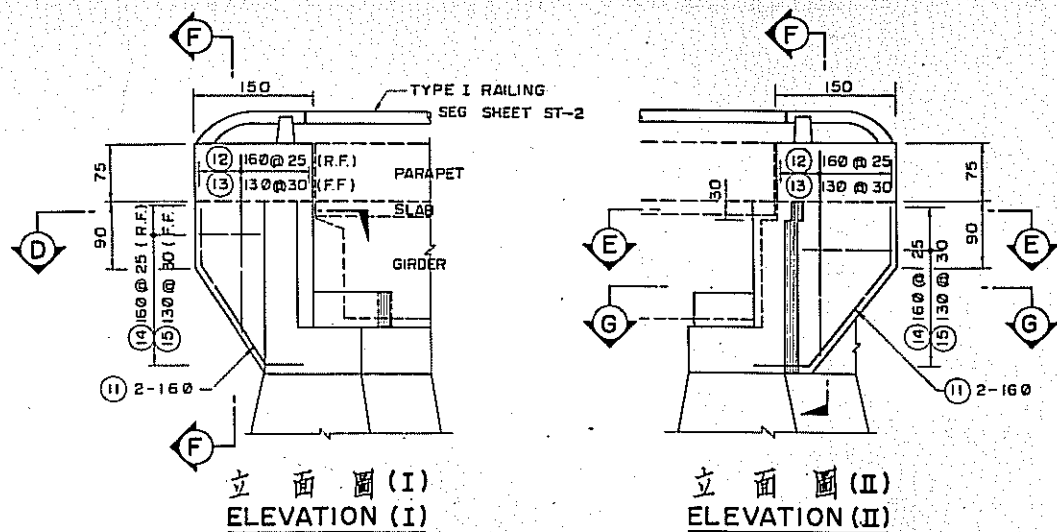

立面圖(I)
ELEVATION (I)

立面圖(II)
ELEVATION (II)

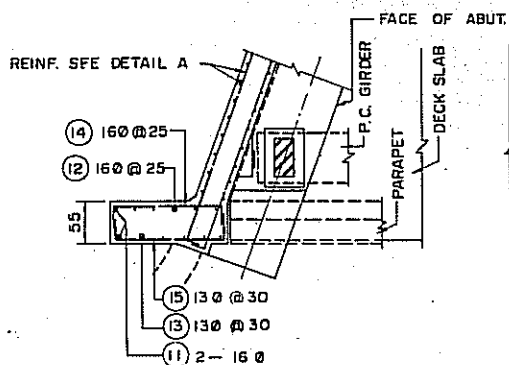

斷面圖 D—D
SECTION D—D

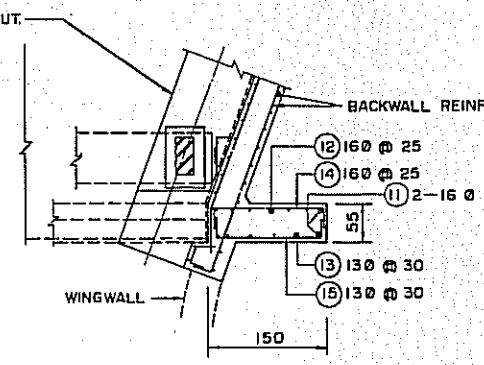

斷面圖 E—E
SECTION E—E

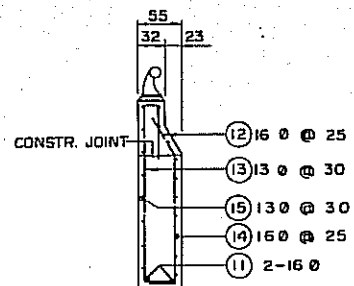

立面圖 F—F
SECTION F—F

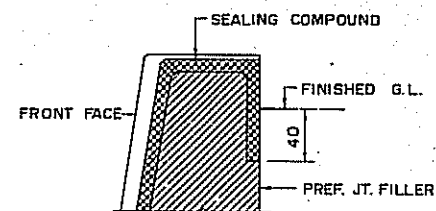

斷面圖 H—H
SECTION H—H

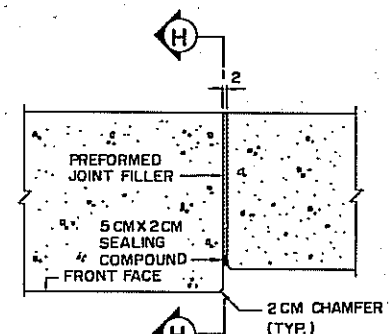

水平斷面圖
HORIZONTAL SECTION

平型伸縮縫詳圖
FLUSH EXPANSION JT. DETAIL
N.T.S.

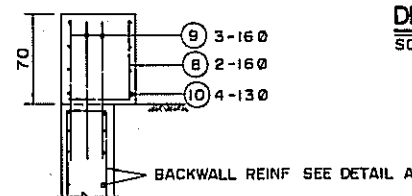

斷面圖 B—B
SECTION B—B
SCALE 1:30

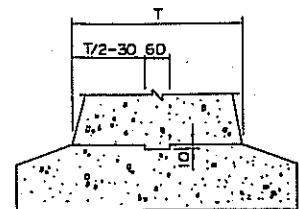

施工縫接榫詳圖
KEYED CONSTR. JT. DETAIL
N.T.S.

詳圖 C
DETAIL C
SCALE 1:50

鋼筋表
LIST OF REINFORCING STEELS

SHAPE	NOMINAL DIA. (MM.)	REMARK
①	160	
②	130	@ 30
③	160	@ 25
④	130	@ 30
⑤	130	@ 25
⑥	130	
⑦	160	@ 20
⑧	160	
⑨	160	
⑩	130	
⑪	160	
⑫	160	@ 25
⑬	130	@ 30
⑭	160	@ 25
⑮	130	@ 30

說明:

- 總說明參照圖 ST-1。
- 混凝土設計應力 $f_c = 240$ 公斤/平方公分。

NOTES:

- FOR GENERAL NOTES SEE SHEET ST-1.
- DESIGN CONC STRESS $f_c = 240$ KG/CM².

STD. DETAILS FOR U/C & CHANNEL BRIDGE

修正 REVISIONS	項目 ITEM	日期 DATE	說明 REMARKS

交通部台灣區高速公路工程局
TAIWAN AREA FREEWAY CONSTRUCTION BUREAU
中華民國
REPUBLIC OF CHINA
南北高速公路 NORTH-SOUTH FREEWAY
苗栗台中段 MIAOLI-TAICHUNG SECTION
橋台詳細圖(III) ABUTMENT DETAILS (III)
中華顧問工程司 CHINA ENGINEERING CONSULTANTS, INC.
日期 DATE AUG. '74 比例 SCALE AS SHOWN 圖號 SHEET ST-10

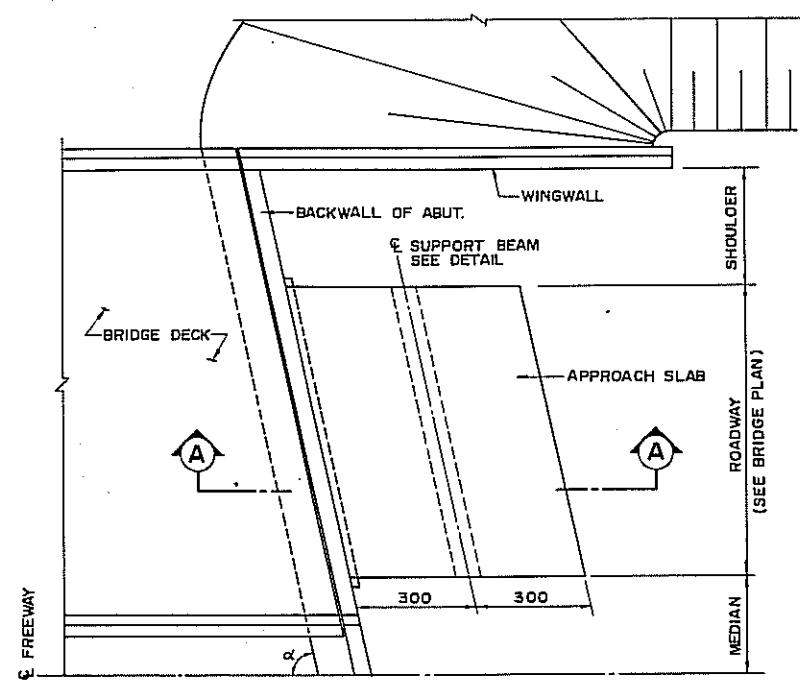

PLAN FOR $70^\circ \leq \alpha \leq 110^\circ$

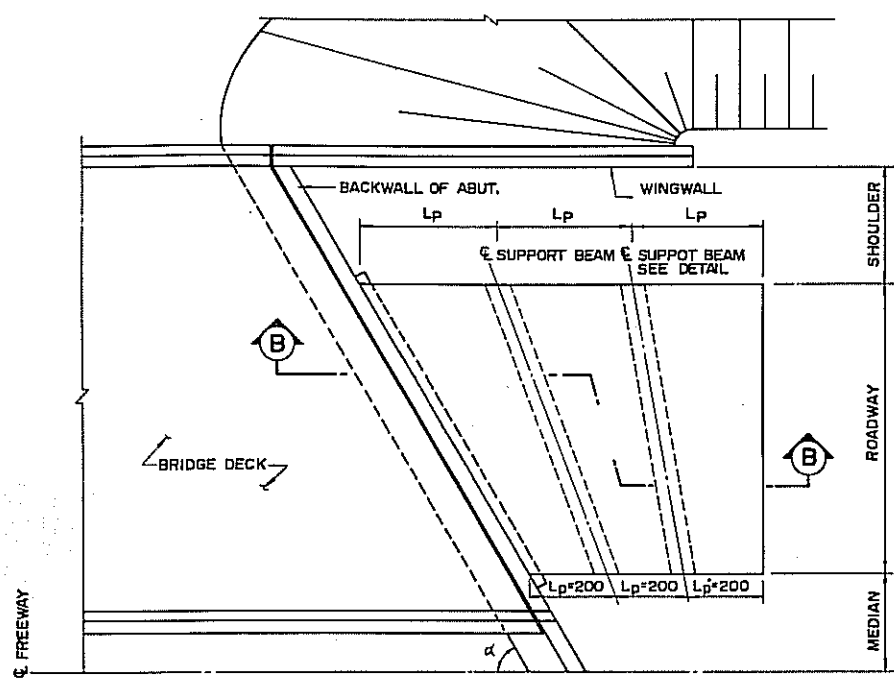

PLAN FOR $\alpha < 70^\circ$ OR $\alpha > 110^\circ$

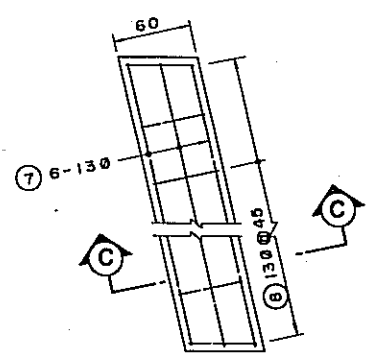

平面圖
PLAN
SCALE 1:30

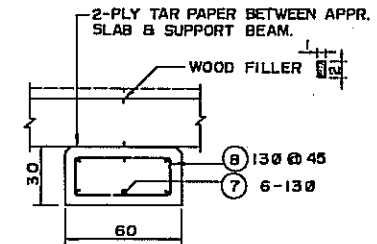

斷面圖 C—C
SECTION C—C
SCALE 1:20

支承樑詳圖
SUPPORT BEAM DETAIL

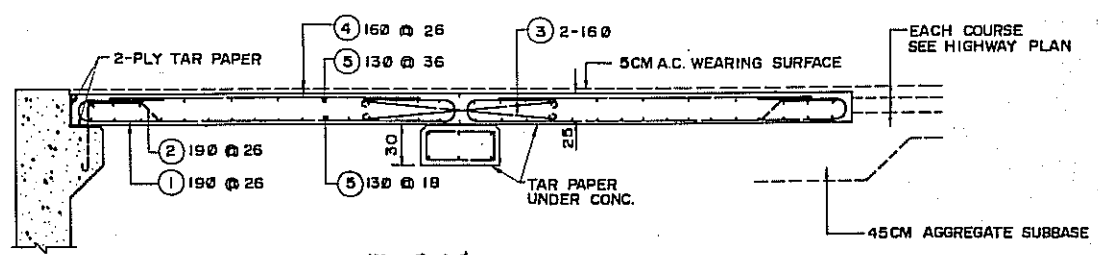

斷面圖 A—A
SECTION A—A

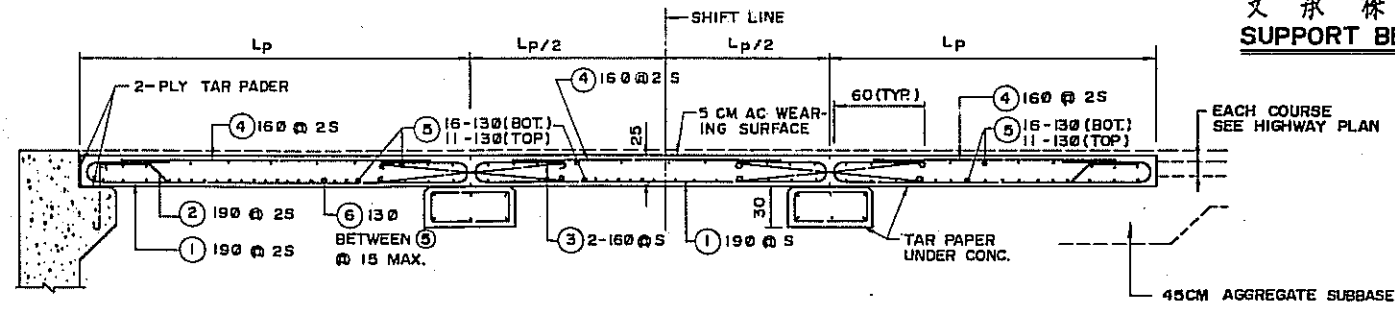

斷面圖 B—B
SECTION B—B
SCALE 1:30

TABLE S

Lp	S	2S
200-269	15	30
270-349	12	24
≥350	10	20

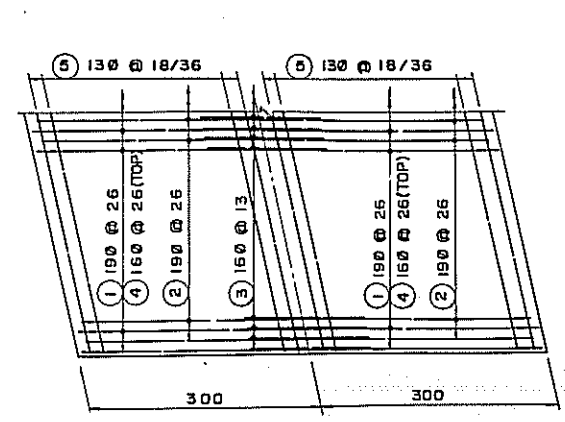

FOR $70^\circ \leq \alpha \leq 110^\circ$

引道版配筋平面圖
APPROACH SLAB REINFORCING PLAN

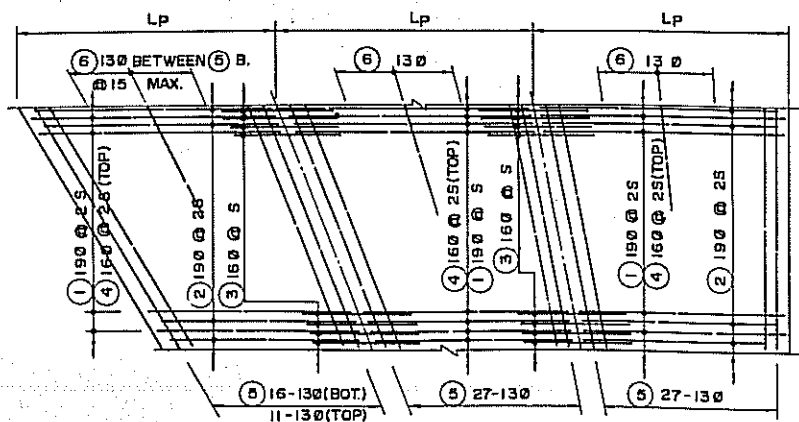

FOR $\alpha < 70^\circ$ OR $\alpha > 110^\circ$

鋼筋表
LIST OF REINFORCING STEELS

SHAPE	NOMINAL DIA. (MM.)	REMARK
①	190	@ 26, 25
②	190	@ 26, 25
③	160	@ 13, S
④	160	@ 26, 25
⑤	130	@ 18/36 VAR.
⑥	130	
⑦	130	
⑧	130	@ 45

說明:

1. 總說明參照圖 ST-1。
2. 引道版下路堤填實密度不低於 AASHTO T-180 方法 C 所測定之 95%。

NOTES:

1. FOR GENERAL NOTES SEE SHEET ST-1.
2. EMBANKMENT UNDER THE APPROACH SLAB SHALL BE COMPACTED TO A DENSITY OF NOT LESS THAN 95% OF THE MAX. DENSITY, AS DETERMINED BY TEST IN CONFORMITY TO AASHTO DESIGNATION T-180 METHOD C.

STD DETAILS FOR U/C & CHANNEL BRID

修正 REVISIONS	項目 ITEM	日期 DATE

交通部台灣區高速公路工程局
TAIWAN AREA FREEWAY CONSTRUCTION BUR
中華民國 REPUBLIC OF CHINA
南北高速公路 NORTH-SOUTH FREEW
苗栗台中段 MIAOLI-TAICHUNG SECTI
引道版詳圖 APPROACH SLAB DETA
中華顧問工程司 CHINA ENGINEERING CONSULTANT
日期 DATE AUG. '74 比例 SCALE AS SHOWN 圖號 SHEET .ST-

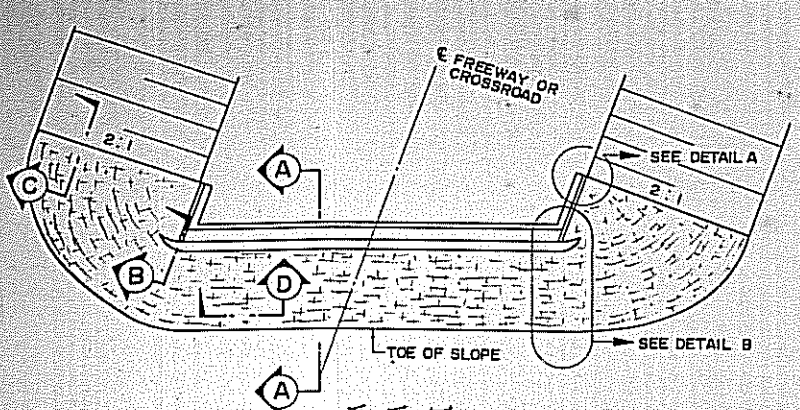

平面圖
PLAN
N.T.S.

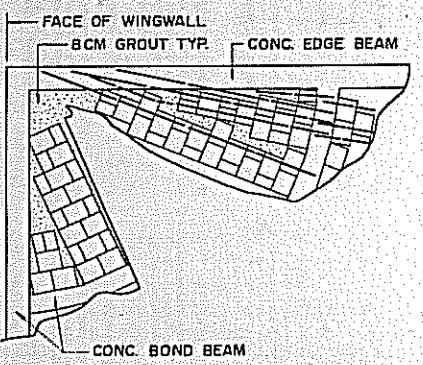

詳圖 A
DETAIL A
N.T.S.

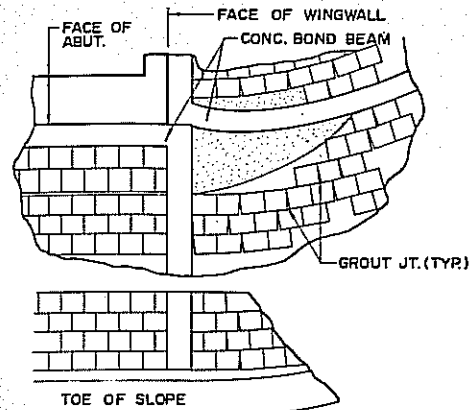

詳圖 B
DETAIL B
N.T.S.

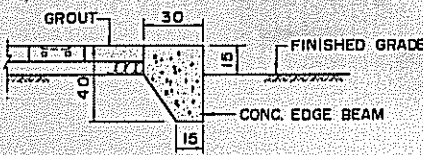

斷面圖 C—C
SECTION C—C
SCALE 1:20

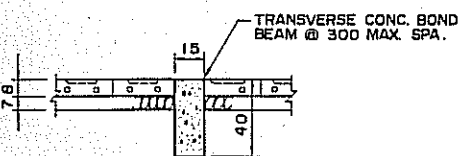

斷面圖 D—D
SECTION D—D
SCALE 1:20

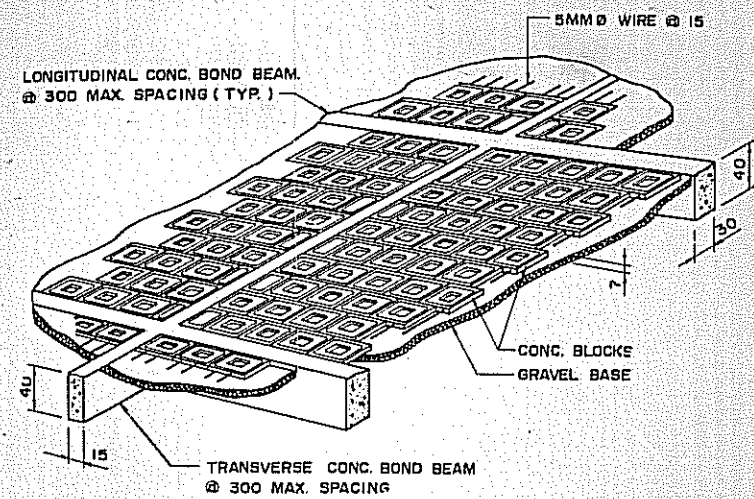

透視圖
PERSPECTIVE
N.T.S.

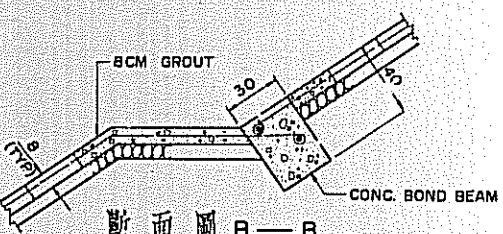

斷面圖 B—B
SECTION B—B
SCALE 1:20

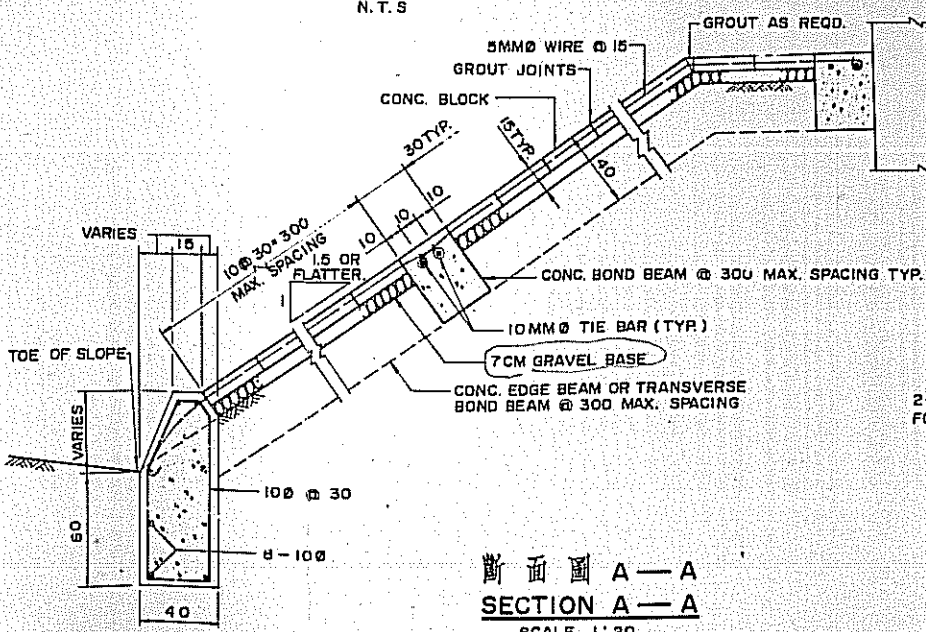

斷面圖 A—A
SECTION A—A
SCALE 1:20

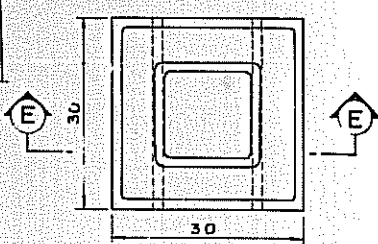

平面圖
PLAN
SCALE 1:6

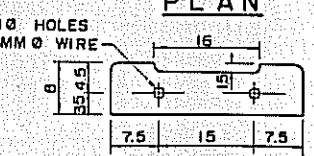

斷面圖 E—E
SECTION E—E
SCALE 1:6

護坡詳圖
SLOPE PROTECTION DETAIL

混凝土塊
CONC. BLOCK
SCALE 1:6

鋼筋彎曲埋入及搭接長度表
TABLE FOR REINFORCING BARS BENDING, EMBEDMENT AND SPLICE

BAR SIZE	DIA. (MM.)	WEIGHT (KG/M)	AREA (CM ²)	MIN. EMBEDMENT LENGTH (CM)			MIN. LAP SPLICES LENGTH (CM)			STANDARD HOOK		STIRRUP & TIE HOOK A (CM.)
				COMP.	TENSION		COMP.	TENSION		180° HOOK A (CM)	90° HOOK A (CM)	
100	9.53	0.559	0.713	20	30	30	30	40	40	13	13	9
130	12.7	0.994	1.27	20	30	30	30	40	40	15	17	11
160	15.9	1.55	1.98	20	35	35	35	45	45	18	22	14
190	19.1	2.24	2.85	25	35	45	40	50	55	21	26	17
220	22.2	3.05	3.88	30	40	60	45	70	75	24	30	-
250	25.4	3.98	5.07	35	55	80	50	90	100	28	35	-
290	28.7	5.06	6.46	40	70	100	55	110	125	38	40	-
320	32.3	6.41	8.17	45	90	125	65	135	160	42	45	-
360	35.8	7.91	10.10	50	110	150	75	160	200	47	50	-

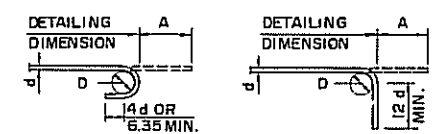

D = 6d FOR 100—250
8d FOR 290—360

(180°) (90°)
標準彎鉤
STANDARD HOOK

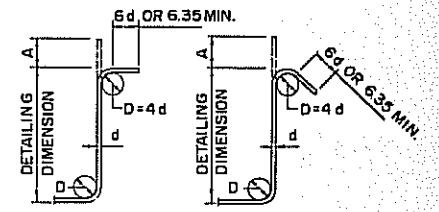

(90°) (135°)
箍及扣條彎鉤
STIRRUP & TIE HOOK

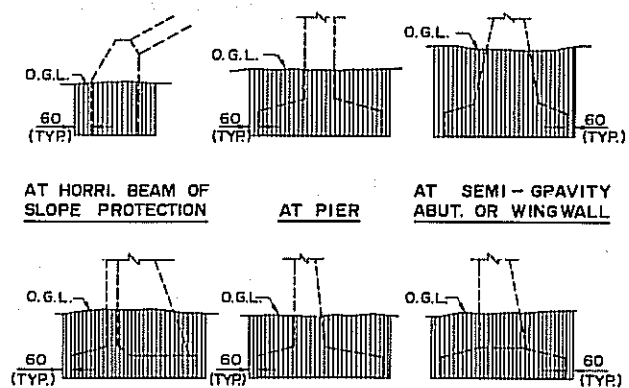

AT COUNTERFORT ABUT. OR WINGWALL AT CANTILEVER ABUT. OR WINGWALL AT SPILL-THROUGH ABUTMENT
結構挖方界限
LIMITS FOR EXCAVATION OF STRUCTURES

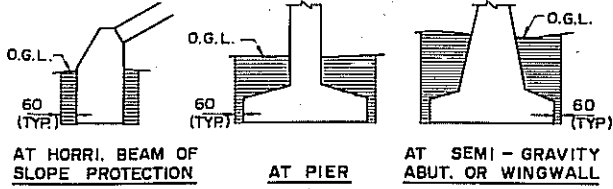

AT COUNTERFORT ABUT. OR WINGWALL AT CANTILEVER ABUT. OR WINGWALL AT SPILL-THROUGH ABUTMENT
結構回填界限
LIMITS FOR BACKFILL OF STRUCTURES

說明

- 總說明參照圖 ST-1。
- 可用焊接或其他可行之連接方法以代替重疊搭接。當採用焊接時，所有焊接方法及材料均須符合規範 "AWS-D12.1" 之規定。
- 除工程師之准許外，所有鋼筋必須冷彎。
- 除圖面註明或工程師之准許外，不得將鋼筋部份埋入混凝土後再行彎曲之。
- 混凝土設計應力：混凝土塊 $f'_c = 240$ 公斤/平方公分。
束桿及基礎 $f'_c = 176$ 公斤/平方公分。

NOTES:

- FOR GENERAL NOTES SEE SHEET ST-1.
- WELDED SPLICES OR OTHER POSITIVE CONNECTIONS MAY BE USED INSTEAD OF LAPPED SPLICES AS PROVIDED HEREIN. ALL WELDING SHALL CONFORM TO AWS-D12.1 "RECOMMENDED PRACTICES FOR WELDING REINFORCING STEEL, METAL INSERTS AND CONNECTIONS IN REINFORCED CONCRETE CONSTRUCTION."
- ALL BARS SHALL BE BENT COLD, UNLESS OTHERWISE PERMITTED BY THE ENGINEER.
- NO BARS PARTIALLY EMBEDDED IN CONCRETE SHALL BE FIELD BENT, EXCEPT AS SHOWN ON THE PLANS OR PERMITTED BY THE ENGINEER.
- CONCRETE DESIGN STRESSES: CONCRETE BLOCK $f'_c = 240 \text{ KG/CM}^2$
BOND BEAM & FOOTING $f'_c = 176 \text{ KG/CM}^2$

STD. DETAILS FOR U/C & CHANNEL BRIDGE

修正 REVISIONS	項目 ITEM	日期 DATE
交通部台灣區高速公路工程局 TAIWAN AREA FREEWAY CONSTRUCTION BUREAU 中華民國 REPUBLIC OF CHINA		
南北高速公路 苗栗台中段 NORTH-SOUTH FREEWAY MIAOLI-TAICHUNG SECTION		
護坡及雜項詳圖 SLOPE PROTECTION & MISC. DETAILS		
中華顧問工程司 CHINA ENGINEERING CONSULTANTS, INC.		
日期 DATE	AUG. '74	比例 SCALE AS SHOWN
圖號 SHEET	ST-12	

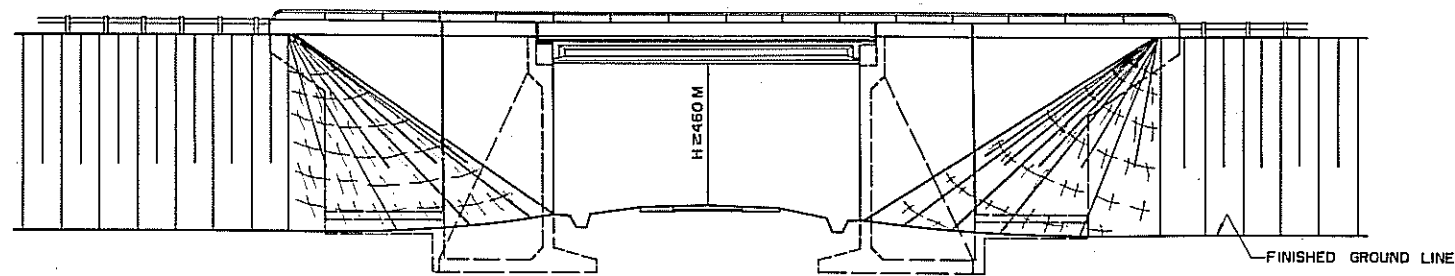

立面圖
ELEVATION
SCALE 1:200

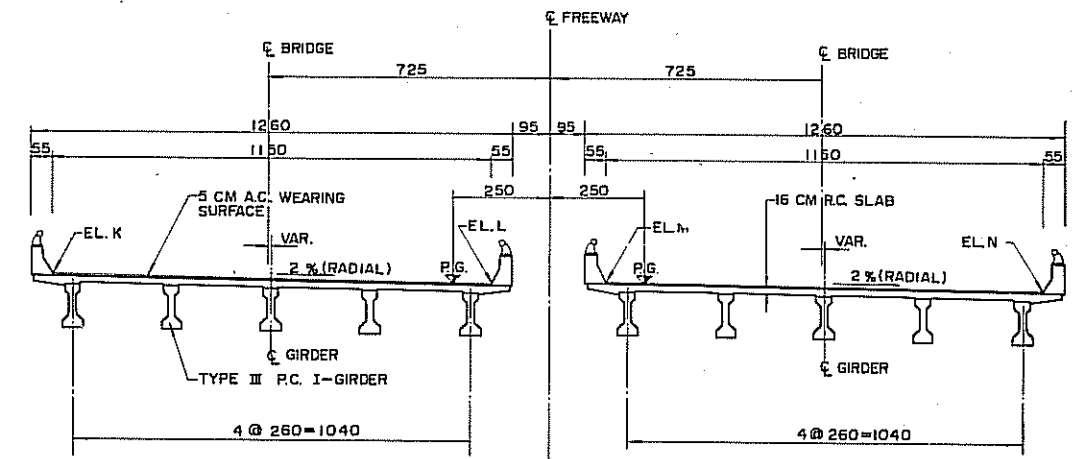

斷面圖 A-A
SECTION A-A
SCALE 1:100

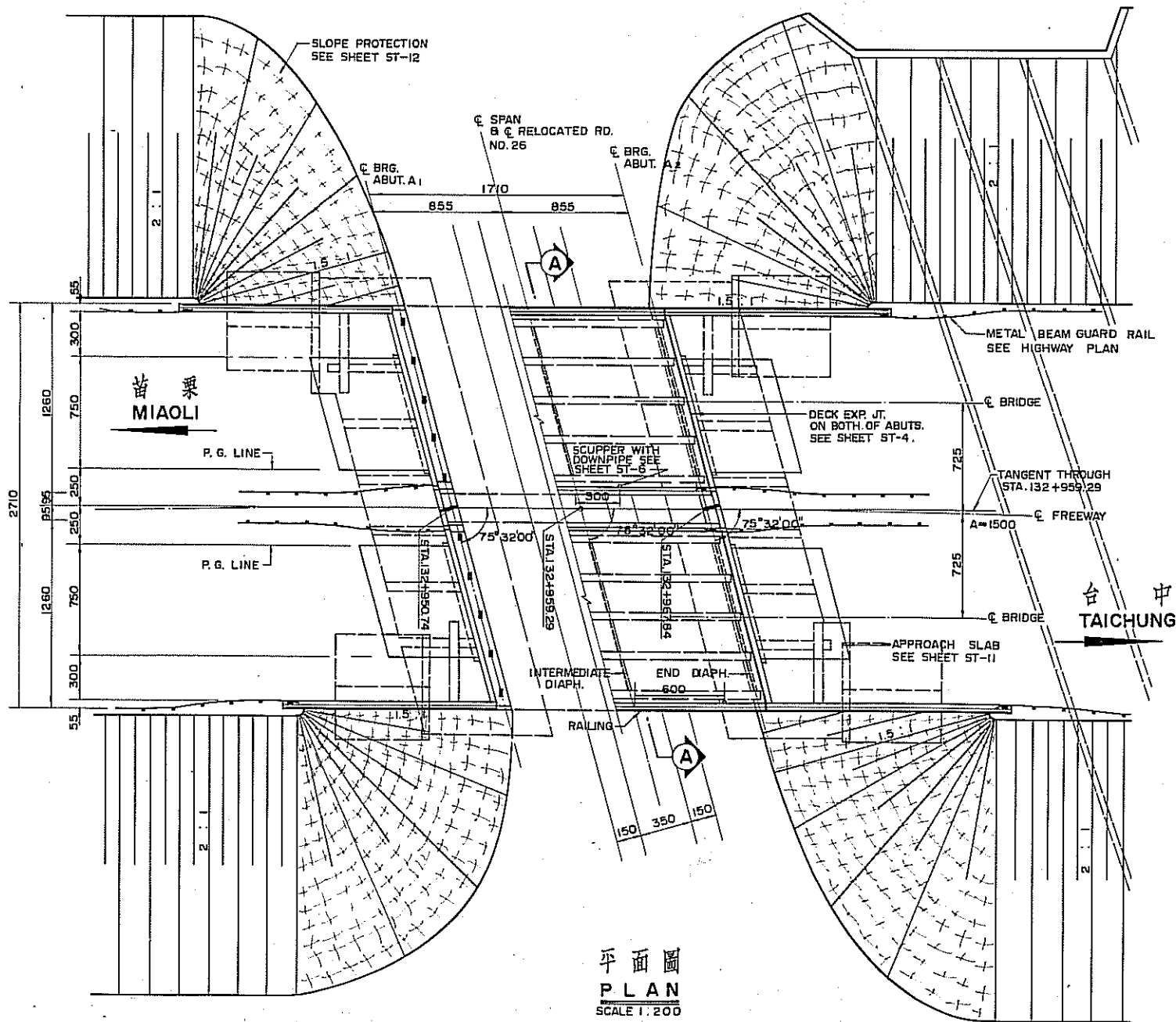

平面圖
PLAN
SCALE 1:200

高程表
LIST OF ELEVATIONS

LOCATION	POINT	K	L	M	N	REMARK
AT \ominus BRG. OF ABUT. A ₁		181.376	181.211	181.267	181.102	
AT \ominus BRG. OF ABUT. A ₂		181.754	181.591	181.649	181.487	

說明：總說明參照圖ST-1。

NOTE: FOR GENERAL NOTES SEE SHEET ST-1.

PROJECT 60

修正 REVISIONS	項目 ITEM	日期 DATE

交通部台灣區高速公路工程局
TAIWAN AREA FREEWAY CONSTRUCTION BUREAU
中華民國
REPUBLIC OF CHINA
南北高速公路 NORTH-SOUTH FREEWAY
苗栗台中段 MIAOLI-TAICHUNG SECTION
穿越橋(132+959.29) HWY 26 UNDERCROSSING
總平面圖 GENERAL PLAN
中華顧問工程司 CHINA ENGINEERING CONSULTANTS, INC.
日期 DATE AUG. '74 比例 SCALE AS SHOWN 圖號 SHEET SU-1

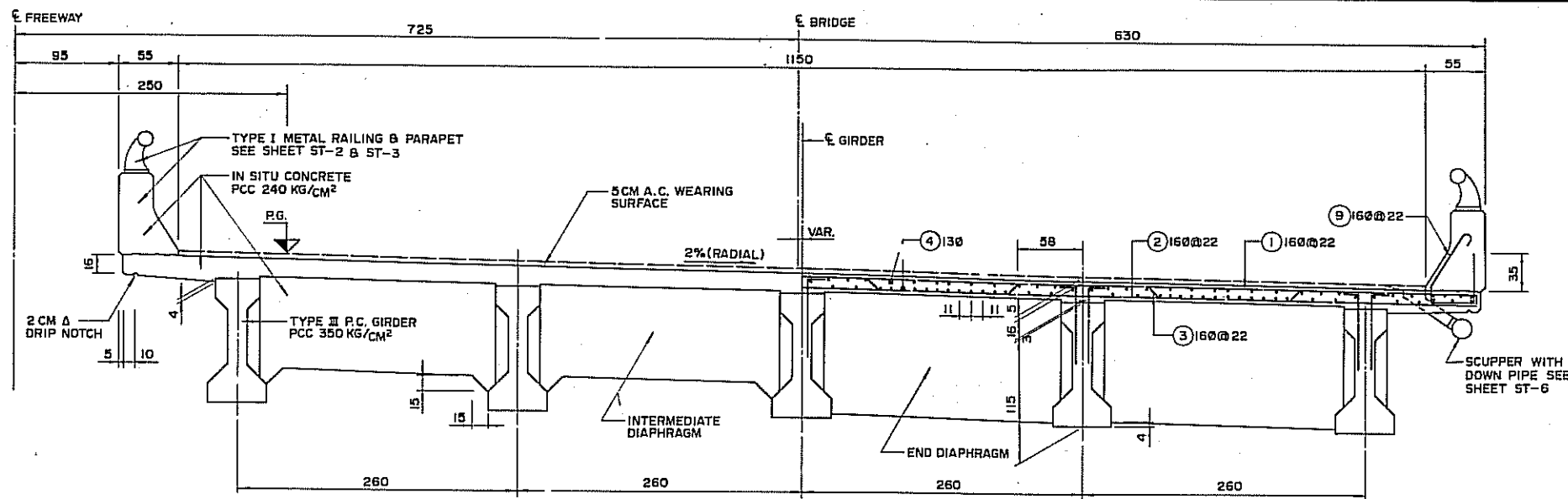

斷面圖 A-A
SECTION A-A
SCALE 1 : 30

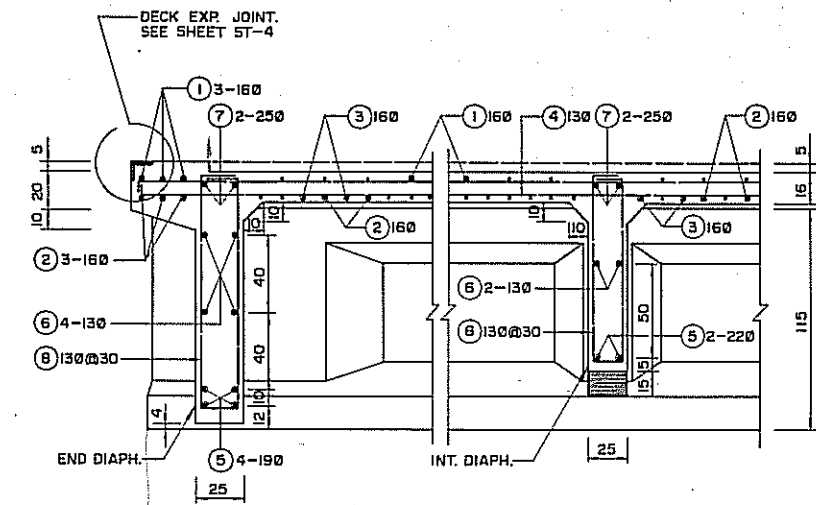

斷面圖 B-B
SECTION B-B
SCALE 1 : 30

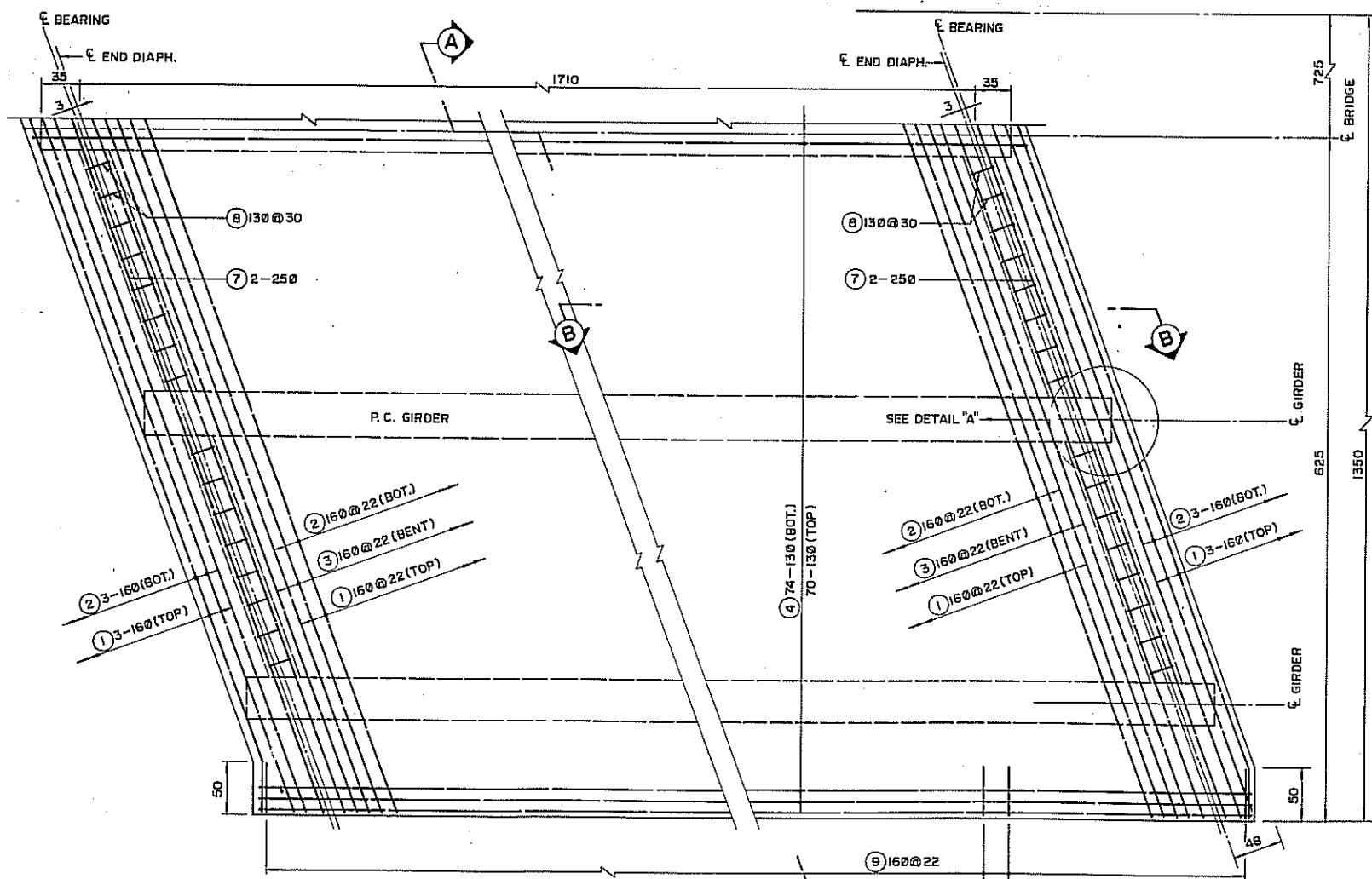

橋面版配筋圖
DECK SLAB REINFORCING PLAN
SCALE 1 : 30

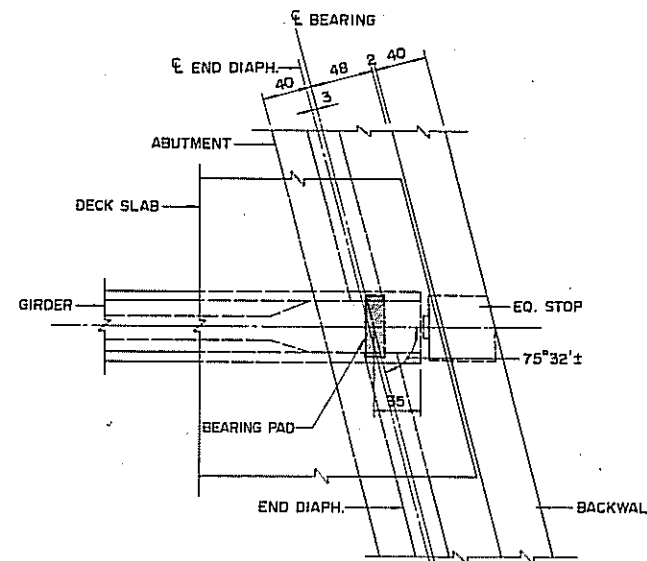

詳圖 A
DETAIL A
SCALE 1 : 30

鋼筋表
LIST OF REINFORCING STEELS

SHAPE	NOMINAL DIA. (MM)	REMARK
①	160	@ 22
②	160	@ 22
③	160	@ 22
④	130	@ 11, 12
⑤	190, 220	END DIAPH. INT. DIAPH.
⑥	130	
⑦	250	
⑧	130	@ 30
⑨	160	@ 22

說明:

1. 鋼筋說明參照圖ST-1。
2. 洩水孔位置參照縱平面圖。

NOTES:

1. FOR GENERAL NOTES SEE SHEET ST-1.
2. FOR LOCATION OF SCUPPER SEE GENERAL PLAN.

PROJECT 60

修正 REVISIONS	項目 ITEM	日期 DATE	交通部台灣區高速公路工程局 TAIWAN AREA FREEWAY CONSTRUCTION BUREAU 中華民國 REPUBLIC OF CHINA
			南北高速公路 NORTH-SOUTH FREEWAY 苗栗台中段 MIAOLI-TAICHUNG SECTION
			穿越橋(132+959.29) HWY 26 UNDERCROSSING 橋版圖 DECK PLAN
			中華顧問工程司 CHINA ENGINEERING CONSULTANTS, INC.
			日期 DATE AUG. '74 比例 SCALE AS SHOWN 圖號 SHEET SU-2

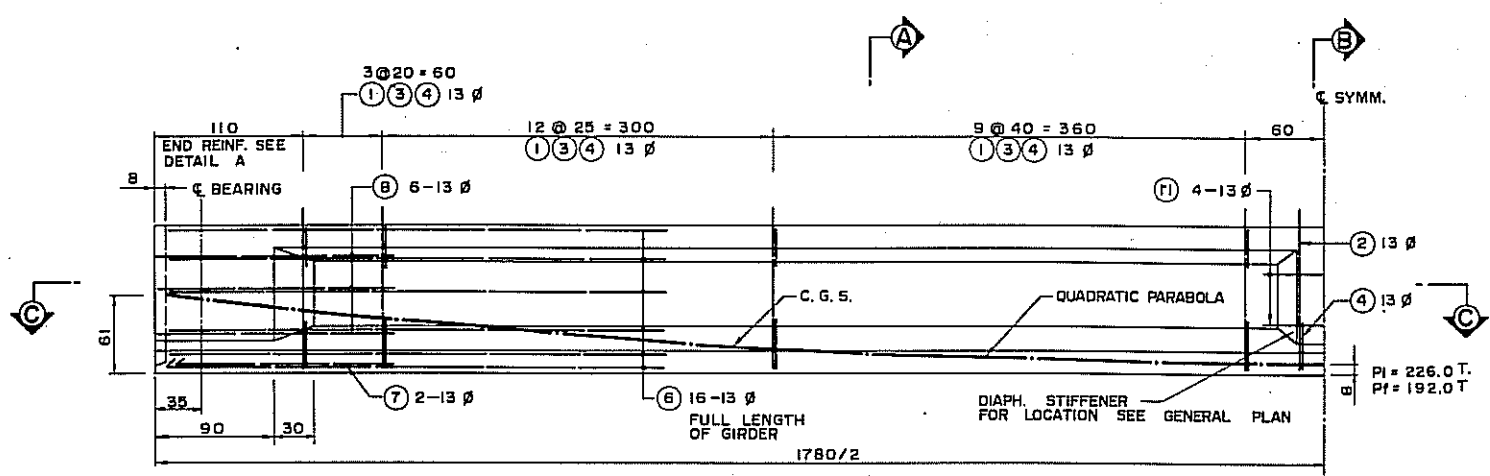

後拉法預力樑
POST-TENSIONED PRESTRESSED GIRDER

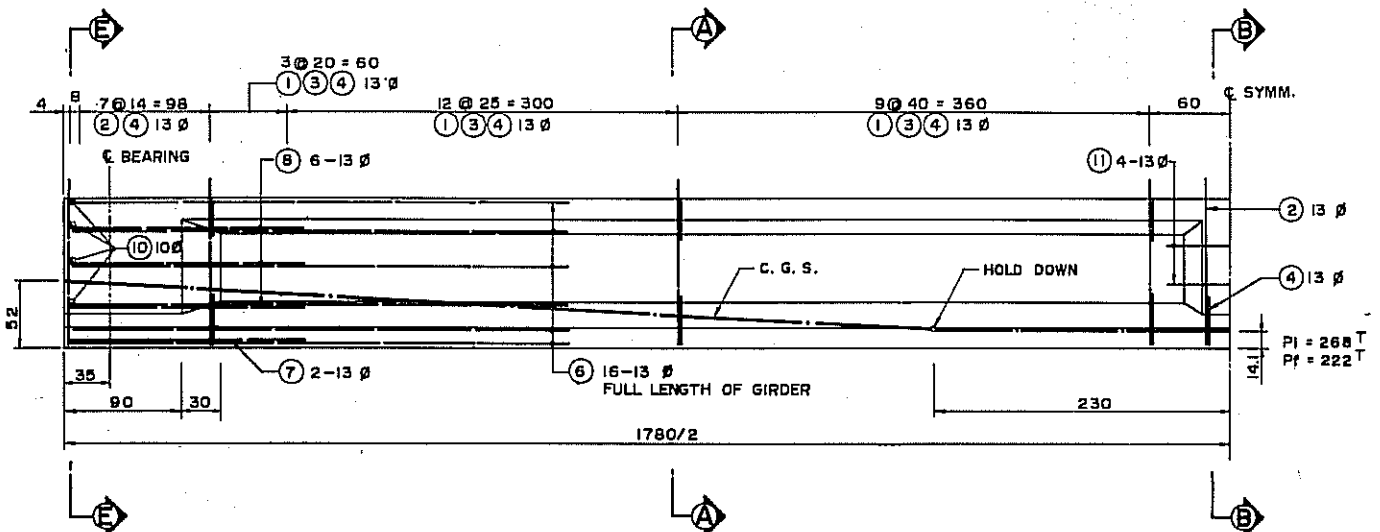

先拉法預力樑
PRE-TENSIONED PRESTRESSED GIRDER

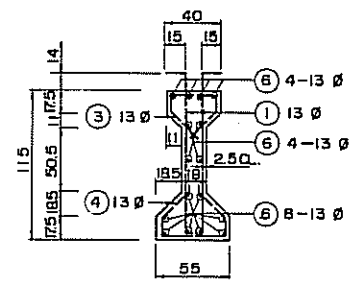

斷面圖 A-A
SECTION A-A

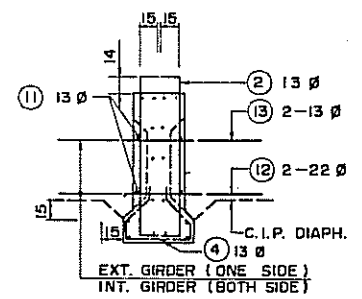

斷面圖 B-B
SECTION B-B

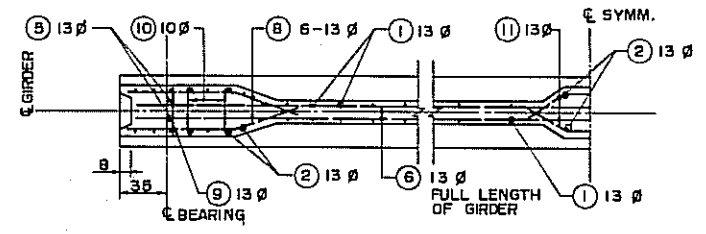

斷面圖 C-C
SECTION C-C

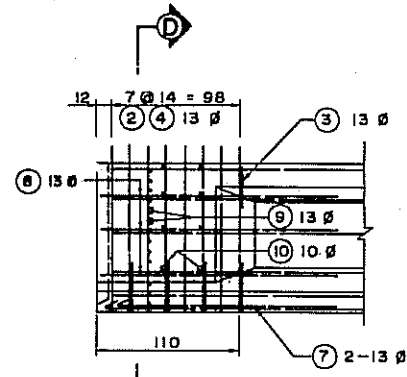

斷面圖 D-D
SECTION D-D

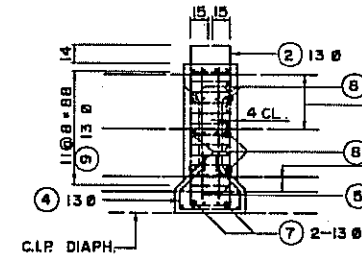

斷面圖 E-E
SECTION E-E

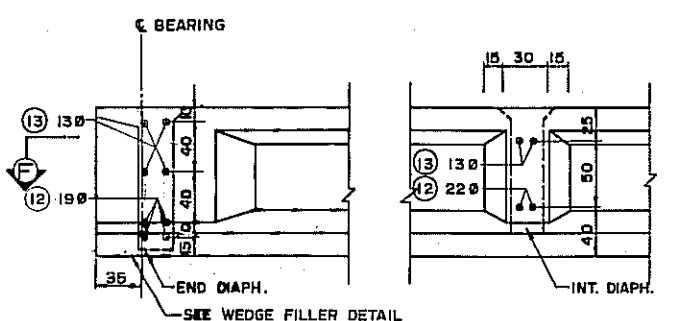

END BLOCK INTERMEDIATE DIAPH.

視面圖
VIEW

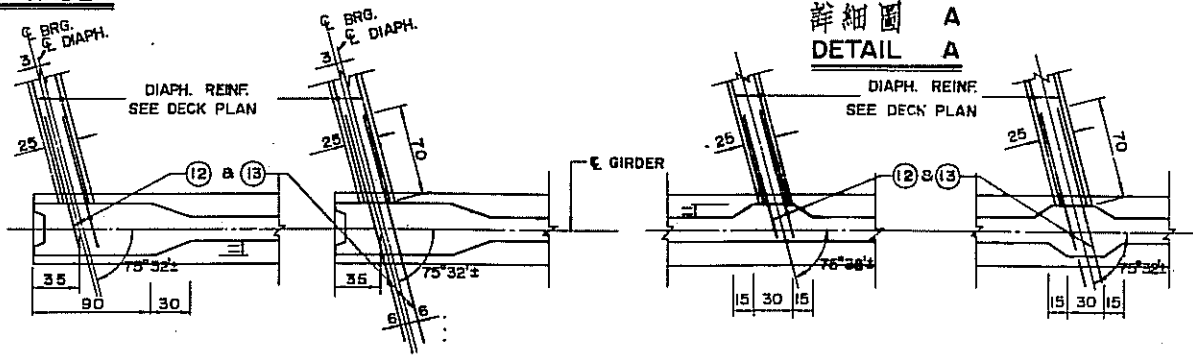

EXTERIOR GIRDER INTERIOR GIRDER EXTERIOR GIRDER INTERIOR GIRDER

詳細圖 A
DETAIL A

斷面圖 F-F
SECTION F-F

鋼筋表
LIST OF REINFORCING STEEL

SHAPE	NOMINAL DIA.(MM)	REMARK
①	13 φ	
②	13 φ	
③	13 φ	
④	13 φ	
⑤	13 φ	
⑥	13 φ	
⑦	13 φ	
⑧	13 φ	
⑨	13 φ	
⑩	10 φ	
⑪	13 φ	
INT. EXT. ⑫	19 φ 22 φ	END DIAPH. INT. DIAPH.
INT. EXT. ⑬	13 φ	
⑭	10 φ	BEHIND THE FREY-SSINET CONE ONLY

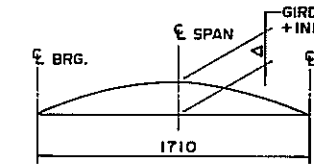

撓度圖
DEFLECTION DIAGRAM

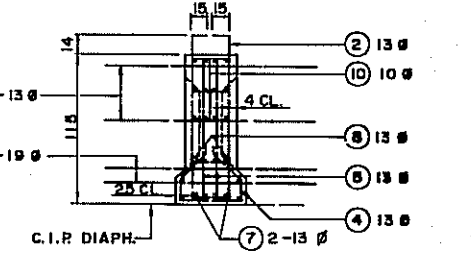

楔形墊詳圖
WEDGE FILLER DETAIL

說明：茲說明及預力樑說明參照圖 ST-1。

NOTE: FOR GENERAL NOTES AND NOTES FOR R.C. GIRDER SEE SHEET ST-1.

PROJECT 60

修正	REVISIONS	項目	ITEM	日期	DATE

交通部台灣區高速公路工程局
TAIWAN AREA FREEWAY CONSTRUCTION BUREAU
中華民國
REPUBLIC OF CHINA
南北高速公路 NORTH-SOUTH FREEWAY
苗栗台中段 MIAOLI-TAICHUNG SECTION
穿越橋(132+959.29) HWY 26 UNDERCROSSING
預力樑 P.C. GIRDER
中華顧問工程司 CHINA ENGINEERING CONSULTANTS, INC.
日期 DATE AUG. '74 比例 SCALE 1:30 圖號 SHEET SU-3

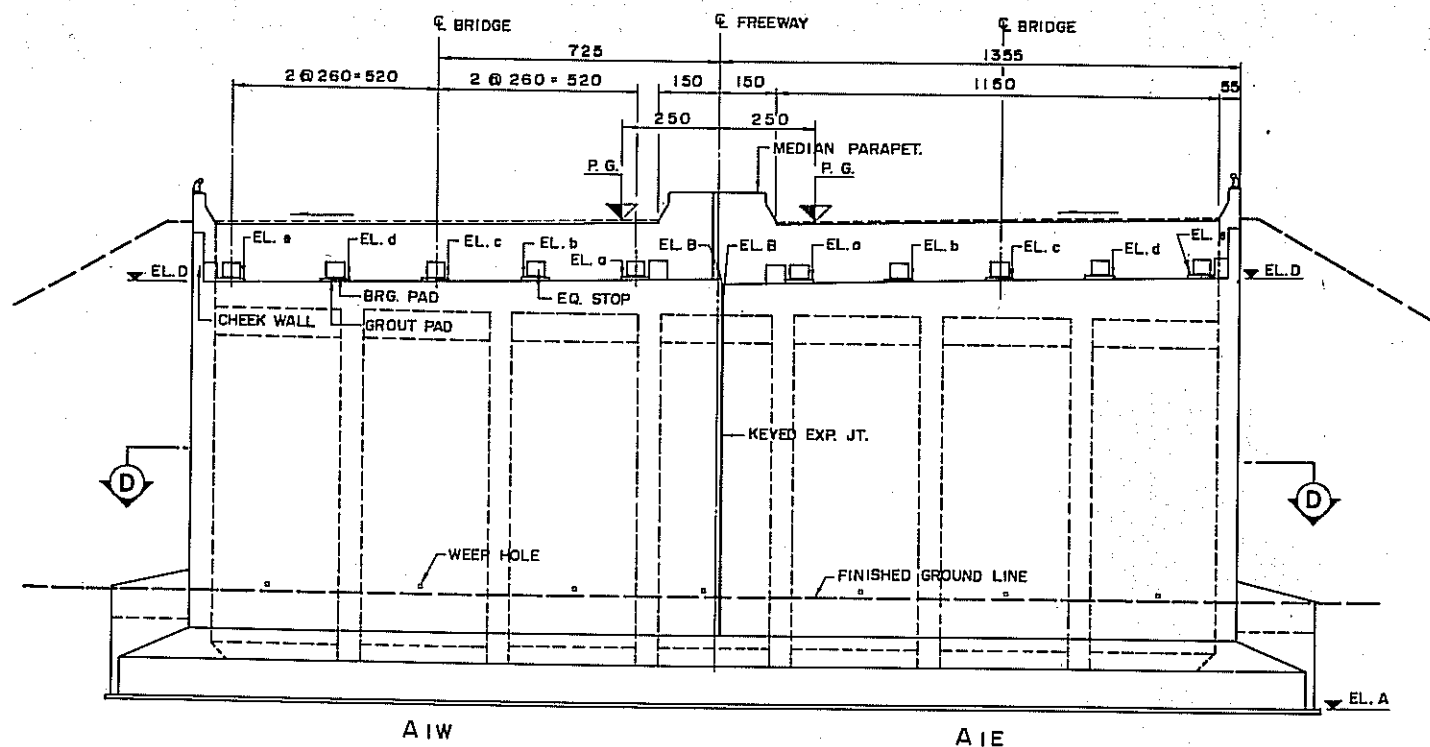

立面圖
ELEVATION
SCALE 1:100

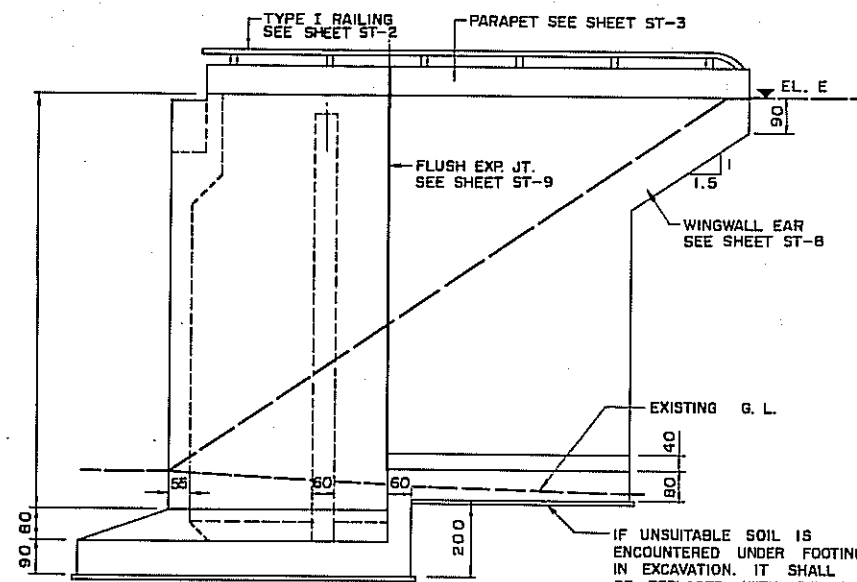

側面圖
SIDE ELEVATION
SCALE 1:100

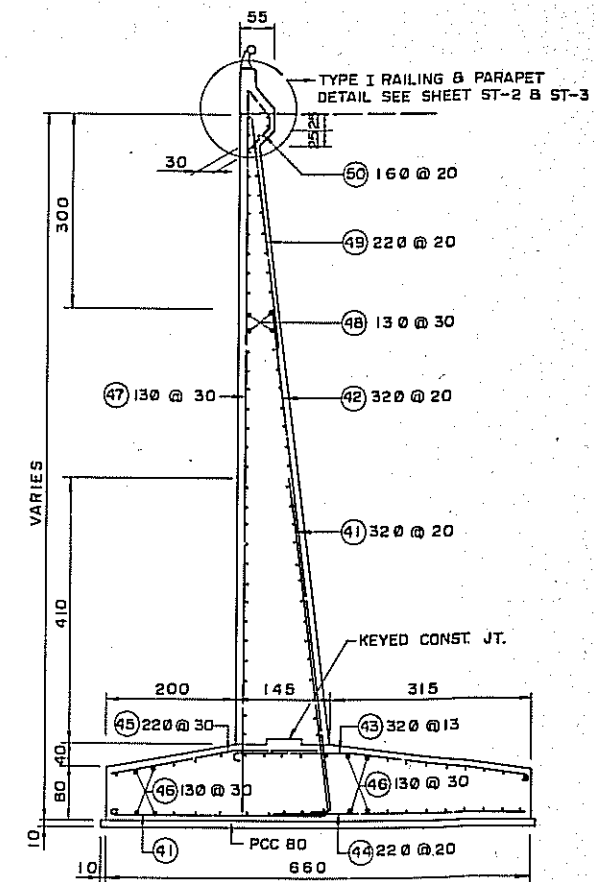

斷面圖 C-C
SECTION C-C
SCALE 1:60

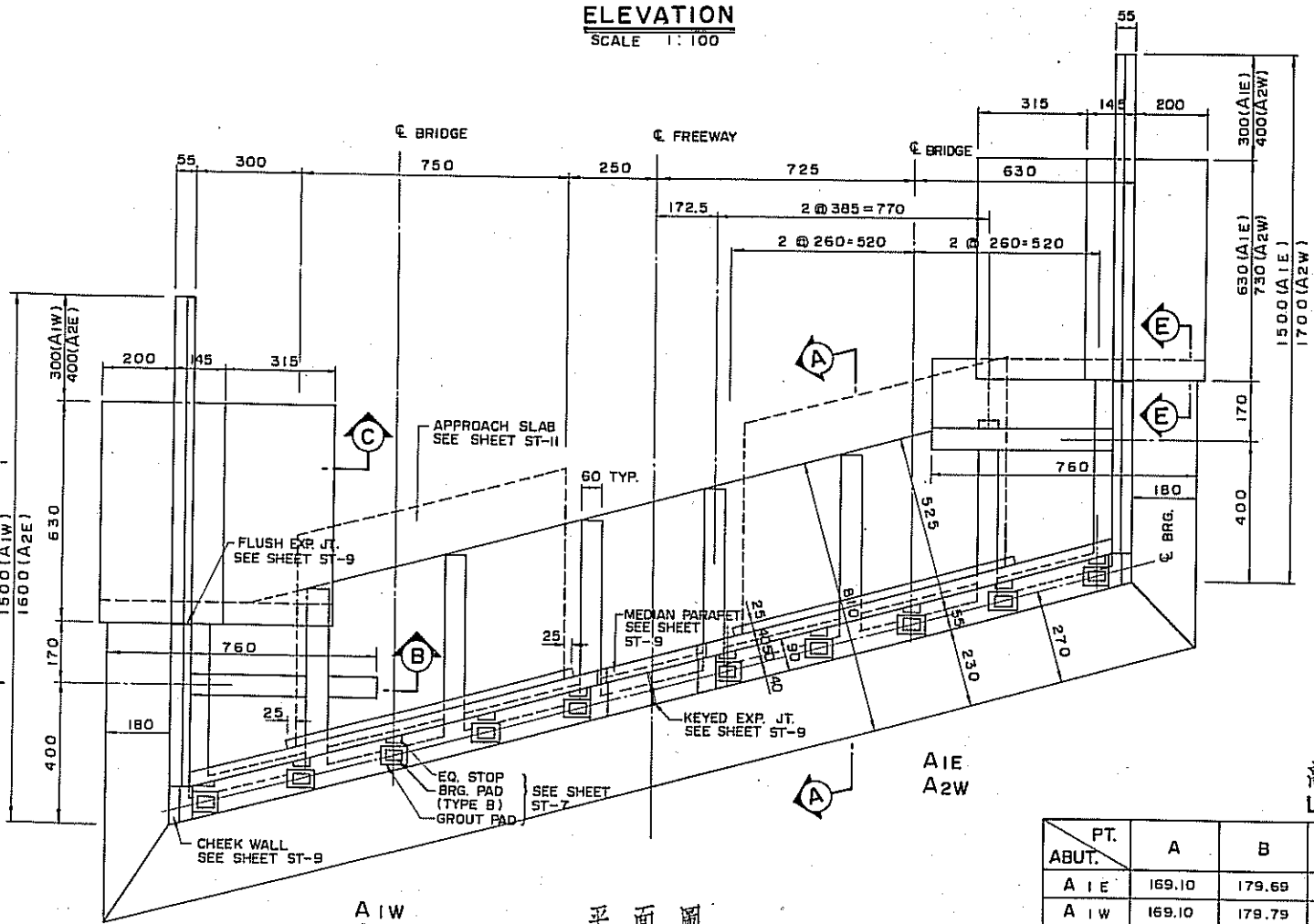

平面圖
PLAN
SCALE 1:100

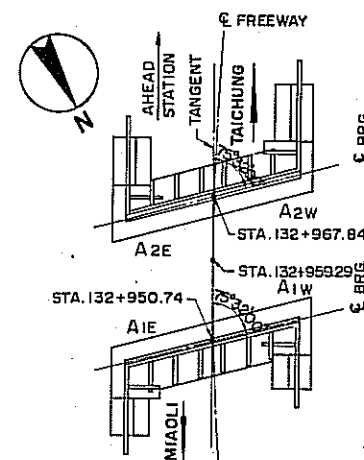

索引圖
KEY PLAN
N.T.S.

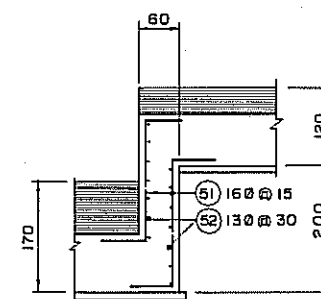

斷面圖 E-E
SECTION E-E
SCALE 1:60

高程表
LIST OF ELEVATIONS

PT. ABUT.	A	B	D	E	TOP OF R.C. GROUT PAD				
					a	b	c	d	e
A 1 E	169.10	179.69	179.88	180.95	179.794	179.831	179.868	179.906	179.944
A 1 W	169.10	179.79	179.59	180.72	179.835	179.797	179.760	179.723	179.685
A 2 E	169.10	180.07	180.26	182.02	180.174	180.211	180.247	180.284	180.321
A 2 W	169.10	180.17	179.98	181.79	180.216	180.179	180.143	180.106	180.070

說明:

1. 橫說明參照圖ST-1.
2. 設計最大蒸發壓力 = 29 噸/平方公尺.

NOTES:

1. FOR GENERAL NOTES SEE SHEET ST-1.
2. MAX DESIGN FOUNDATION PRESSURE = 29 T/M².

PROJECT 60

修正 REVISIONS	項目 ITEM	日期 DATE

交通部台灣區高速公路工程局
TAIWAN AREA FREEWAY CONSTRUCTION BUREAU
中華民國
REPUBLIC OF CHINA
南北高速公路 NORTH-SOUTH FREEWAY
苗栗台中段 MIAOLI-TAICHUNG SECTION
穿越橋(132+959.29) HWY 26 UNDERCROSSING
橋台(I) ABUTMENT (I)
中華顧問工程司 CHINA ENGINEERING CONSULTANTS, INC
日期 DATE AUG. '74 比例 SCALE AS SHOWN 圖號 SHEET SU-4

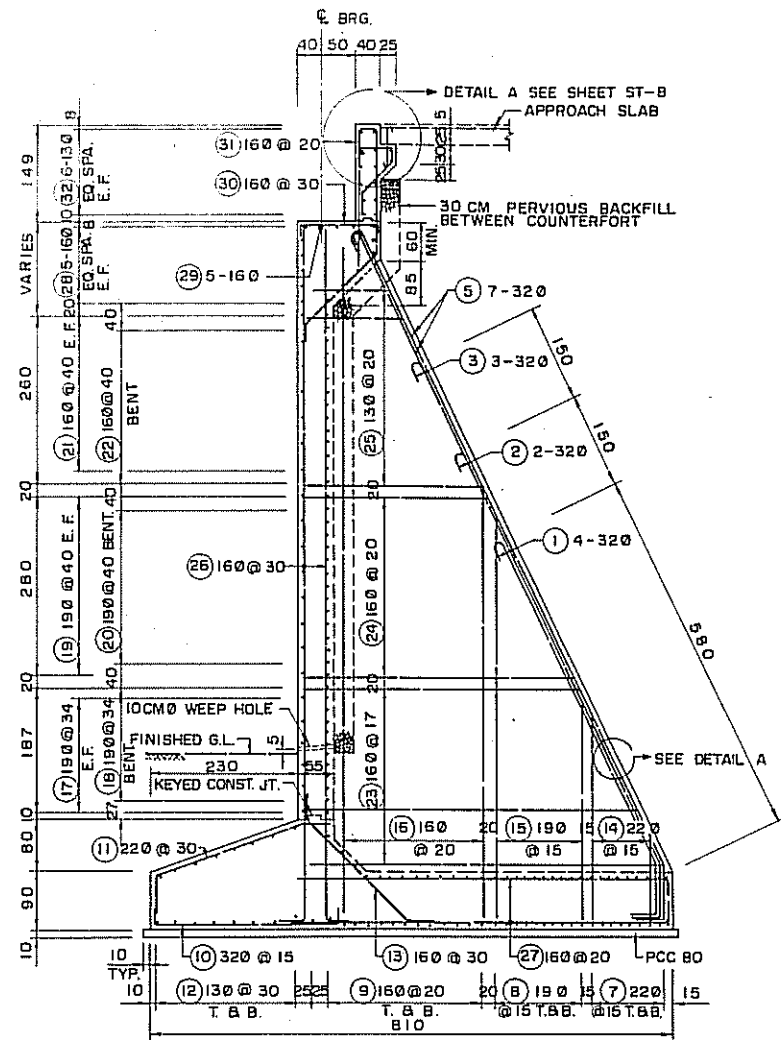

斷面圖 A—A
SECTION A—A
SCALE 1:60

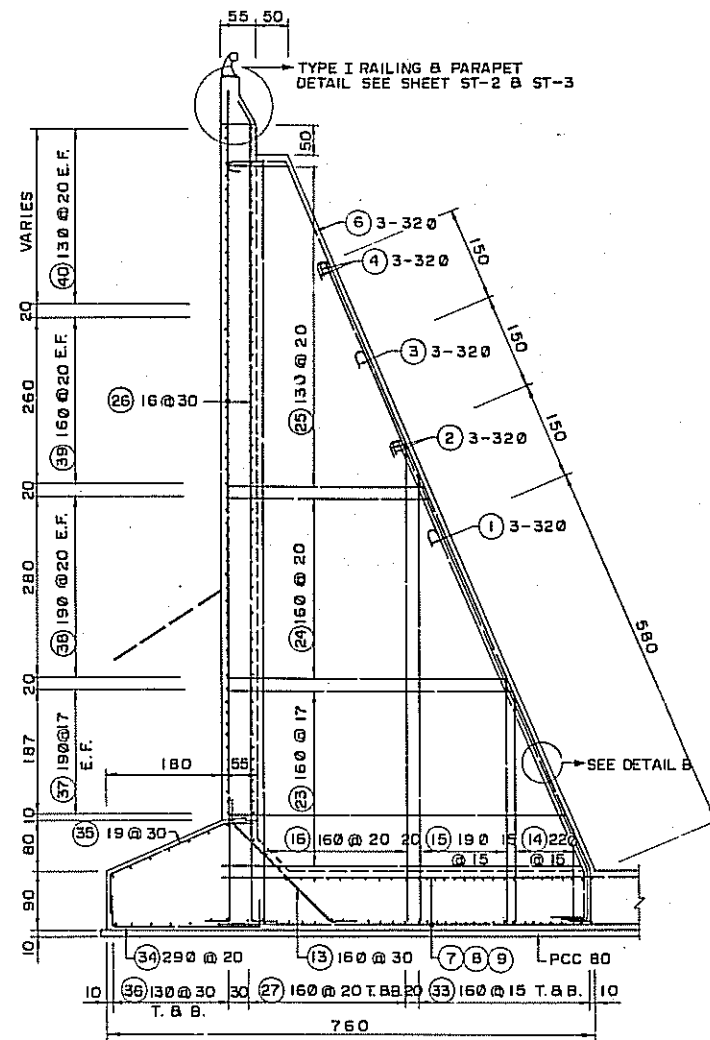

斷面圖 B—B
SECTION B—B
SCALE 1:60

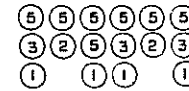

詳圖 A
DETAIL A



詳圖 B
DETAIL B



詳圖 C
DETAIL C

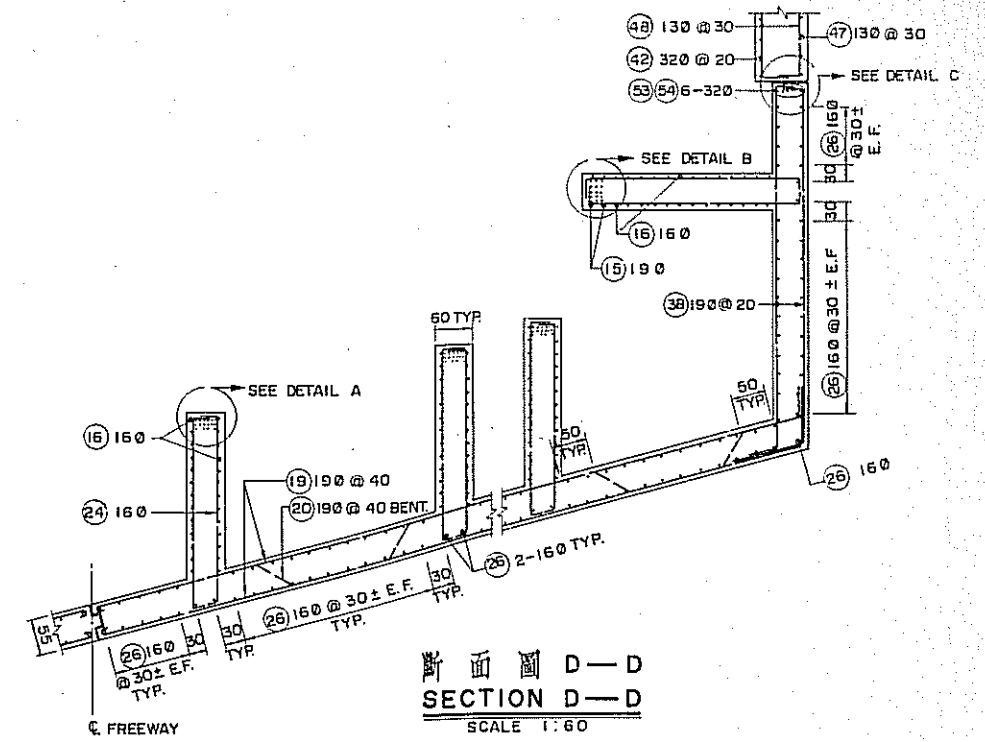

斷面圖 D—D
SECTION D—D
SCALE 1:60

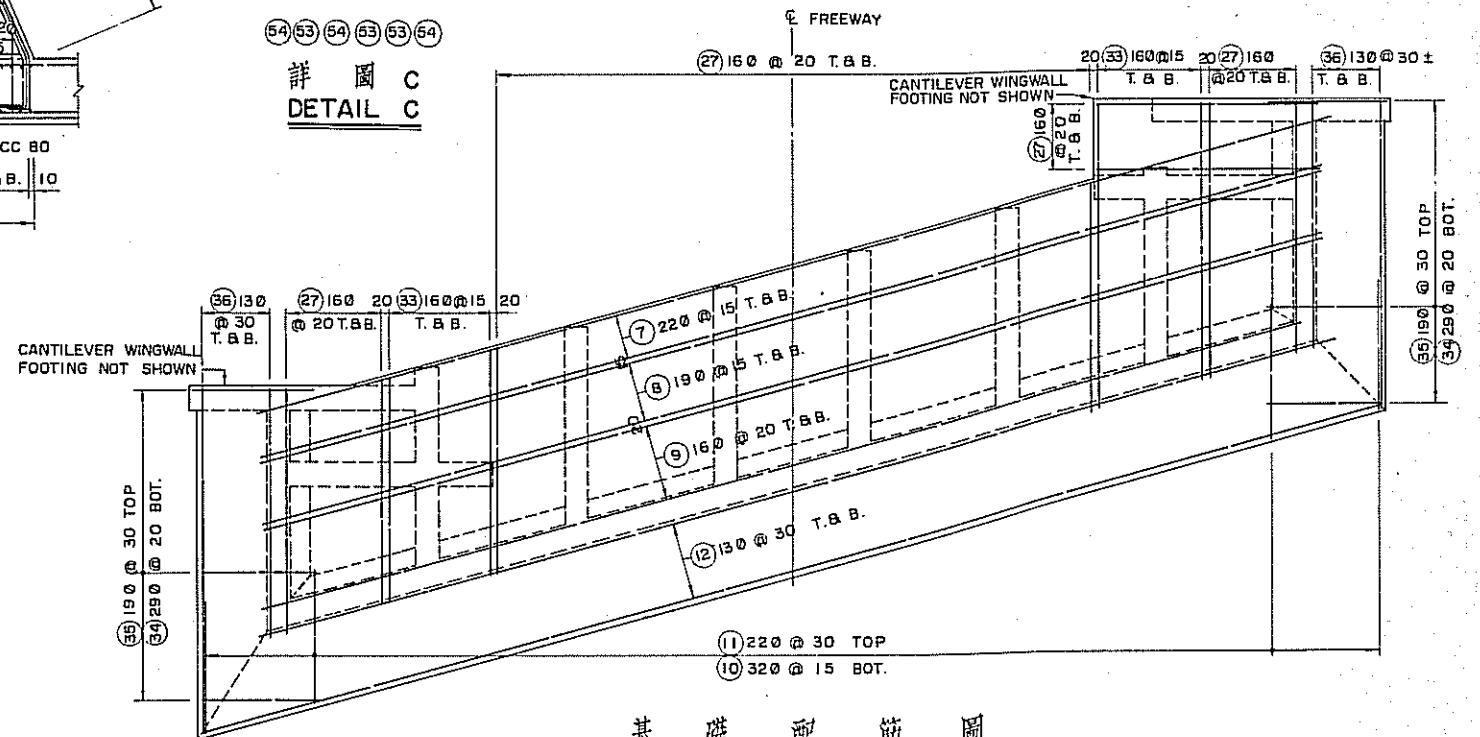

基礎配筋圖
FOOTING REINFORCEMENT
SCALE 1:100

鋼筋表
LIST OF REINFORCING STEELS

SHAPE	NORMINAL DIA. (M.M.)	REMARK	SHAPE	NORMINAL DIA. (M.M.)	REMARK	SHAPE	NORMINAL DIA. (M.M.)	REMARK
1	320		19	190	∅ 40	37	190	∅ 17
2	320		20	190	∅ 40	38	190	∅ 20
3	320		21	160	∅ 40	39	160	∅ 20
4	320		22	160	∅ 40	40	130	∅ 20
5	320		23	160	∅ 17	41	320	∅ 20
6	320		24	160	∅ 20	42	320	∅ 20
7	220	∅ 15	25	130	∅ 20	43	320	∅ 13
8	190	∅ 15	26	160	∅ 30	44	220	∅ 20
9	160	∅ 20	27	160	∅ 20	45	220	∅ 30
10	320	∅ 15	28	160		46	130	∅ 30
11	220	∅ 30	29	160		47	130	∅ 30
12	130	∅ 30	30	160	∅ 30	48	130	∅ 30
13	160	∅ 30	31	160	∅ 20	49	220	∅ 20
14	220	∅ 15	32	130	∅ 20	50	160	∅ 20
15	190	∅ 15	33	160	∅ 15	51	160	∅ 15
16	160	∅ 20	34	290	∅ 20	52	130	∅ 30
17	190	∅ 34	35	190	∅ 30	53	320	
18	190	∅ 34	36	130	∅ 30	54	320	

PROJECT 60

修正 REVISIONS	項目 ITEM	日期 DATE	交通部台灣區高速公路工程局 TAIWAN AREA FREEWAY CONSTRUCTION BUREAU 中華民國 REPUBLIC OF CHINA
			南北高速公路 NORTH-SOUTH FREEWAY 苗栗台中段 MIAOLI-TAICHUNG SECTION
			穿越橋(132+959.29) HWY 26 UNDERCROSSING 橋台(II) ABUTMENT (II)
			中華顧問工程司 CHINA ENGINEERING CONSULTANTS, INC. 日期 DATE: AUG. '74 比例 SCALE: AS SHOWN 圖號 SHEET: SU-5